

BELRAY II

MODEL 097
DENTAL X-RAY

**OPERATOR'S
INSTRUCTIONS**
(for USA & Canada)

⚠ WARNING

This X-ray equipment may be dangerous to patients and operators unless safe exposure factors and operating instructions are observed.

 Belmont®

INDEX

	PAGE
[1] INTRODUCTION -----	1
[2] LAYOUT OF CONTROLS -----	3
[3] FUNCTION OF CONTROLS -----	4
[4] OPERATING PROCEDURES -----	6
[5] OPTIONAL HAND EXPOSURE SWITCH -----	6
[6] DIGITAL IMAGING SYSTEM -----	7
[7] CLEANING AND DISINFECTION -----	7
[8] DISPOSAL OF USED FILM AND CCD COVERS -----	7
[9] ERROR CODES -----	8
[10] MAINTENANCE -----	9
[11] TECHNICAL DATA -----	10
[12] ELECTROMAGNETIC COMPATIBILITY(EMC) -----	11

Intended Use of the Product

BELRAY II MODEL 097 is a extraoral source dental radiographic x-ray unit. This unit works as a diagnostic purpose x-ray source for human teeth with the resultant image recorded on intraoral dental x-ray film or image receptor.

[1] INTRODUCTION

1. GENERAL

This manual provides information for the operation and maintenance procedures and technical specifications for BELRAY II MODEL 097 dental x-ray. The instructions contained in this book should be thoroughly read and understood before operation.

BELRAY II MODEL 097 has no user serviceable items. Maintenance and repair should be performed by qualified dealer service personnel.

2. PARTS IDENTIFICATION OF X-RAY SYSTEM "BELRAY II" MODEL 097

- a. Tube housing assembly : 097-H
- b. X-ray controls : 097-CM (main controller), 097-CS (sub controller)
- c. Cones : 097-R (regular), 097-L (long)
- d. Balance arm : 097-A

3. COMPLIANCE WITH STANDARD

BELMONT BELRAY II MODEL 097 x-ray unit complies with the following standard.

- a. Electrical and Mechanical Safety
 - IEC60601-1 : 1988
 - UL60601-1 : 2003
- b. Radiation Safety
 - 21 CFR 1020.30

4. CLASSIFICATION























4-1. According to Section 513 of Federal Food, Drug and Cosmetic Act and 21 CFR Part 806, BELMONT BELRAY II MODEL 097 is classified as CLASS II Medical Device.

4-2. According to IEC60601-1, BELMONT BELRAY II MODEL 097 is classified as follows.

- a. Protection against electric shock : Class I Equipment, Type B Applied Parts
- b. Protection against ingress of water : Ordinary
- c. Mode of operation : Continuous Operation with Intermittent Loading
(Duty Cycle = 1 : 50)
- d. Equipment not suitable for use in the presence of a flammable anesthetic mixture with air or with oxygen or nitrous oxide.

5. SYMBOL

In this book, on the labels or on the control panel of BELRAY II MODEL 097, following symbols are used. Confirm the meaning of each symbol.

	Consult written Instructions in Manuals		Protection against electric shock : Type B		ON (POWER)		OFF (POWER)
	Protection Grounding		Exposure Switch		X-ray Emission		Ready
	Upper Incisor		Upper Cuspid & Pre Molar		Upper Molar		Occlusal
	Lower Incisor		Lower Cuspid & Pre Molar		Lower Molar & Bite Wing		Bite Wing
	Digital Imaging		Patient Child		Patient Normal		Patient Obese
	Regular Cone		Long Cone				

6. SAFETY

This X-ray Unit may be dangerous to patient and operator, if safe exposure factors and operating instructions are not observed.

Only qualified and authorized personnel may operate this equipment observing all laws and regulations concerning protection.

- The operator at all times must remain 6ft. (2m) from the X-ray head for operator protection.
- Fully use all radiation safety features of the equipment.
- Fully use all radiation protection devices, accessories and procedures available to protect the patient and operator from x-ray radiation.

[2] LAYOUT OF CONTROLS

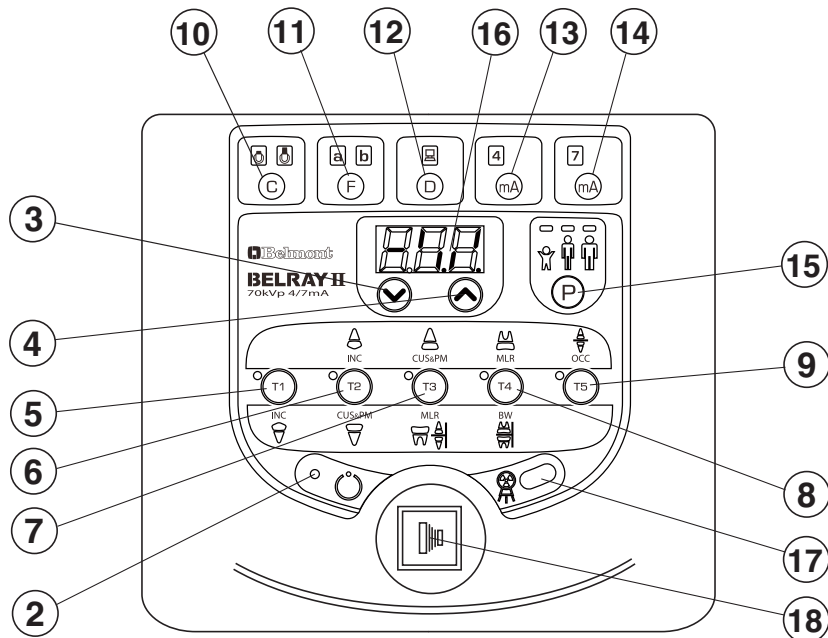
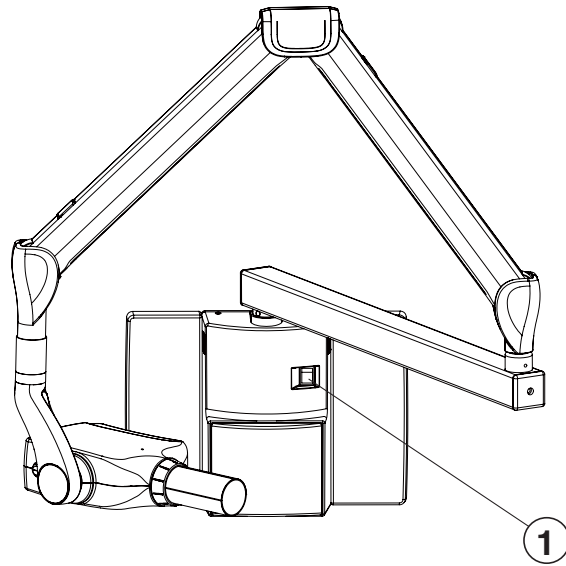

- | | |
|---|------------------------------------|
| (1) Main Power Switch | (10) Cone Type Selection Switch |
| (2) Ready Light | (11) Film Speed Selection Switch |
| (3) Exposure Time Adjusting Switch (Down) | (12) Digital Imaging Switch |
| (4) Exposure Time Adjusting Switch (Up) | (13) 4mA Selection Switch |
| (5) Tooth Selection Switch (T1) | (14) 7mA Selection Switch |
| (6) Tooth Selection Switch (T2) | (15) Patient Size Selection Switch |
| (7) Tooth Selection Switch (T3) | (16) Exposure Time Display Window |
| (8) Tooth Selection Switch (T4) | (17) Exposure Warning Light |
| (9) Tooth Selection Switch (T5) | (18) Exposure Switch |

[3] FUNCTION OF CONTROLS

(1) Main Power Switch

Pushing the upper side of this switch to the ON position energizes the x-ray unit. (Ready light and pre-select lights for cone type, film or digital, 4mA, 7mA and patient size illuminate.)

It is recommended to keep this switch OFF when the unit is not in use, in order to prevent an accidental exposure.

IMPORTANT : To prevent the risk of an accidental exposure, push the lower side of this switch to the OFF position, when the unit is not in use.

(2) Ready Light

This light illuminates when the line voltage is within operable range (108 ~ 132Vac).

When this light is not on, exposure can not be made.

(3) (4) Exposure Time Adjusting Switches

By momentarily pushing the $\text{\textcircled{\small \wedge}}$ (or $\text{\textcircled{\small \vee}}$) switch, the exposure time displayed increases (or decreases) by one increment. By keeping the switch depressed more 2 sec., the exposure time displayed increases (or decreases) continuously until the switch is released.

Model 097 has the following 23 exposure time settings :

0.00, 0.02, 0.03, 0.04, 0.05, 0.06, 0.08, 0.10, 0.13, 0.16, 0.20, 0.25, 0.32, 0.40
0.50, 0.63, 0.80, 1.00, 1.25, 1.60, 2.00, 2.50, 3.20 (sec.)

(5) (9) Tooth Selection Switches (T1 ~ T5)

Pushing one of these switches sets the exposure time automatically for the following (10) ~ (15).

(5) T1 : Incisor of Mandible

(6) T2 : Incisor of Maxilla, Cuspid & Premolar of Mandible

(7) T3 : Cuspid & Premolar of Maxilla, Molars of Mandible, Bitewing

(8) T4 : Molar of Maxilla, Bitewing Molars

(9) T5 : Occlusal

If the T1 switch (5) is depressed more than 3 sec. unit goes into “Lock Mode”. In lock mode, the only functional switch is the power switch. To exit from the lock mode, depress the T1 switch more than 3 sec. again.

(10) Cone Type Selection Switch

Depressing this switch for more than 2 sec. selects the cone type : 8” standard cone or 12” optional long cone. (If the optional rectangular cone is to be used, select the 8” standard cone setting.)

(11) Film Speed Selection Switch

a. BELRAY II has 16 film speed settings. (F.00 ~ F.15)

Two speed settings are pre-set at the factory (a & b) and can be selected with switch (11).

a = Film speed No. F.09 (equivalent to ISO speed group “D”, or Kodak Ultra-Speed film)

b = Film speed No. F.04 (equivalent to ISO speed group “F/E”, or Kodak InSight film)

b. Pushing this switch momentarily displays the selected film speed setting in the **Exposure Time Display Window** (16).

Depressing this switch for more than 2 sec. changes the film type being selected.

c. If the **Digital Imaging Switch** (12) is depressed, both of the film speed indicating lights (a & b) are turned off.

(12) Digital Imaging Switch

If a digital imaging system is used, shorter exposure time is often required. BELRAY II has 16 speeds for digital imaging (d.00 ~ d.15). Pushing this switch momentarily displays the speed being selected in the **Exposure Time Display Window** (16). With the factory speed setting d.06, the exposure time becomes half of F.06 setting.

TABLE 1. Speed Setting and Exposure Time (Regular Cone) [unit : sec.]

Speed Setting	mA	Child					Adult					Large Adult				
		T1	T2	T3	T4	T5	T1	T2	T3	T4	T5	T1	T2	T3	T4	T5
F.09	4	0.25	0.40	0.50	0.63	1.00	0.40	0.63	0.80	1.00	1.60	0.50	0.80	1.00	1.25	2.00
	7	0.13	0.25	0.25	0.40	0.50	0.25	0.40	0.50	0.63	0.80	0.25	0.50	0.63	0.80	1.00
F.04	4	0.10	0.16	0.20	0.25	0.40	0.16	0.25	0.32	0.40	0.63	0.20	0.32	0.40	0.50	0.80
	7	0.06	0.10	0.10	0.16	0.20	0.10	0.16	0.20	0.25	0.40	0.10	0.20	0.25	0.32	0.40
d.06	4	0.08	0.13	0.13	0.20	0.25	0.13	0.20	0.25	0.32	0.50	0.13	0.25	0.32	0.40	0.50
	7	0.04	0.06	0.08	0.10	0.16	0.06	0.10	0.13	0.16	0.25	0.08	0.13	0.16	0.20	0.32

TABLE 2. Speed Setting and Exposure Time (Long Cone) [unit : sec.]

Speed Setting	mA	Child					Adult					Large Adult				
		T1	T2	T3	T4	T5	T1	T2	T3	T4	T5	T1	T2	T3	T4	T5
F.09	4	0.50	0.80	1.00	1.25	2.00	0.80	1.60	1.60	2.50	3.20	1.00	1.60	2.00	2.50	*2.50
	7	0.32	0.50	0.63	0.80	1.25	0.50	0.80	1.00	1.25	2.00	0.63	1.00	1.25	1.60	2.50
F.04	4	0.20	0.32	0.40	0.63	0.80	0.32	0.63	0.63	1.00	1.25	0.40	0.63	0.80	1.25	1.60
	7	0.13	0.20	0.25	0.32	0.50	0.20	0.32	0.40	0.50	0.80	0.25	0.40	0.50	0.63	1.00
d.06	4	0.16	0.25	0.32	0.40	0.63	0.25	0.40	0.50	0.63	1.00	0.32	0.50	0.63	0.80	1.25
	7	0.08	0.16	0.16	0.25	0.32	0.13	0.25	0.25	0.40	0.50	0.16	0.32	0.32	0.50	0.63

(13) 4mA Selection Switch

By momentarily depressing this switch, the tube current is set at 4mA.

When Film switch is depressed, the tube current setting will be automatically changed to 7mA.

(14) 7mA Selection Switch

By momentarily depressing this switch, the tube current is set at 7mA.

When Digital switch is depressed, the tube current setting will be automatically changed to 4mA.

(15) Patient Size Selection Switch

This switch alters the selection of patient type/size to be radiographed (child→adult→large→child) and sets the exposure time automatically.

NOTE : Setting or adjusting the exposure time manually (with ⤴ or ⤵ switch) supersedes (5) ~ (15) functions.

(16) Exposure Time Display Window

This window displays the selected exposure time. If an abnormal condition exists or a malfunction occurs, an Error Code is displayed. (See Section : [4] **ERROR CODES**)

(17) Exposure Warning Light

Illumination of this light indicates the unit is producing x-radiation.

(18) Exposure Switch

This switch initiates radiographic exposure. When making an exposure, depress and hold this switch until the **Exposure Warning Light** (17) and the audible warning shut off. Failure to keep this switch depressed will result in the premature termination of the exposure and an error code E.00 will be displayed in **Exposure Time Display Window** (16).

[4] OPERATING PROCEDURES

1. Turn ON the Main Power Switch (1).
2. Confirm that Ready Light (2) is illuminated.

NOTE : The ready light will not illuminate unless the incoming line voltage is correct and within the x-ray's operable range (108 ~ 132VAC).

3. Select the appropriate tooth type (5) ~ (9), and confirm the pre-selected conditions (cone type, film or digital, mA and patient size) are suitable for exposure.

NOTE : To manually set the exposure time, depress either of the manual Exposure Time Adjusting Switches (⤴ or ⤵) until the desired exposure time appears in the Exposure Time Display Window (16). While the unit is in manual mode, other selection switches (5) ~ (15) do not affect exposure time. (All of the tooth selection lights are off.) To return to the automatic exposure time selection mode, depress any one of Tooth Selection Switches (5) ~ (15).

4. Depress the Exposure Switch (18). When the Exposure Switch is depressed, the Exposure Warning Light (17) illuminates and the audible warning sounds. Do not release the Exposure Switch until the Exposure Warning Light and audible warning automatically shut off. Failure to keep the switch depressed will result in exposure being terminated prematurely.
5. To continue to radiograph other teeth, just select appropriate Tooth Selection Switches (5) ~ (9).

IMPORTANT : To protect x-ray tubehead from heat accumulation, wait for a time interval that is equal to 50 times the selected exposure time before making additional exposures. (Example : a 25 sec. wait is necessary between exposures that are 0.5 sec. in duration.)

6. Turn OFF the Main Power Switch (1) in order to prevent accidental exposures when the unit is not in use.

NOTE : If the unit left over 8 min. without being operated and the Main Power Switch (1) is kept on, figure "1" runs through the Exposure Time Display Window (16). This does not mean that malfunction of the unit has occurred ; this is an energy saving feature. The unit returns to ready condition by pressing any one of the switches, except the Exposure Switch (18).

[5] OPTIONAL HAND EXPOSURE SWITCH

Optional hand exposure switch can be connected to the sub controller. Since this exposure switch has a coiled cord, operators can stand in the most suitable position for operation.

As controller has separate connector for this exposure switch, both exposure switch (18) on the front panel of sub controller and this hand exposure switch can be used.

If local code prohibits use of both, ask installer to disconnect the connector of either switch.

[6] DIGITAL IMAGING SYSTEM

If electrical instruments such as a digital imaging system is used with BELRAY II MODEL 097 x-ray, the following points should be confirmed to keep electrical safety .

WARNING

The use of ACCESSORY equipment not complying with the equivalent safety requirements of BELRAY II MODEL 097 may lead to a reduced level of safety of the resulting system.

Consideration relating to the choice shall include :

- **use of the accessory in the PATIENT VICINITY**
- **evidence that the safety certification of the ACCESSORY has been performed in accordance to the appropriate IEC60601-1 and/or IEC60601-1 harmonized national standard.**

[7] DISINFECTION AND CLEANING

1. DISINFECTION

(a) X-ray operator is required to wear disposable gloves when taking radiographs and handling contaminated film packet or digital detector cover. Gloves should be changed for each patient to avoid cross contamination. X-ray head, main controller and sub controller should be covered by single use barriers.

(b) If you use film holders or digital detector holders that go into patient's mouth, properly sterilize them. Follow the sterilization procedures indicated by each manufacturer.

2. CLEANING

In order to ensure proper hygiene and cleaning of the equipment, the following procedures must be followed :

CAUTION

Before cleaning the unit, turn off the main power switch and breaker on the branch line. This is required because some internal parts remain connected to main voltage even when the main power switch has been turned off.

Wipe the outside surface with a paper towel dampened with a disinfectant solution or household, non abrasive cleaner. DO NOT SPRAY SOLVENT OR LIQUID DIRECTLY ON THE X-RAY UNIT. BE CAREFUL NOT TO ALLOW SOLVENTS TO RUN OR DRIP into the BELRAY II. This could cause damage to the BELRAY II. Allow surfaces to air dry before turning breaker and main switch back on.

Unacceptable Disinfectants

The following chemicals may damage equipment:

- * Bleach
- * Phenol / Alcohol combinations
- * Foam spray products
- * Benzalconium chloride solutions

Parts in contact with skin :

To ensure proper cleaning of these parts, periodic disinfection with a non corrosive surface disinfectant is recommended.

[8] DISPOSAL OF USED FILM AND DIGITAL DETECTOR COVERS

Process the abandonment such as the film covers and digital detector covers appropriately, according to the procedures indicated by each manufacturer and the local codes for disposal.

[9] ERROR CODES

If an abnormal condition exists in the unit, or a malfunction occurs, an error code is displayed in the Exposure Time Display Window (16). Please refer to the Table below.

Error Code	Condition	Step to be Taken	Possible Solution
E.00	Exposure switch was released before exposure termination.	All the tooth selection lights blink. Depress one of the tooth switches.	Release the exposure switch after the exposure light turns off.
E.01	Exposure switch was depressed within 10 sec. of previous exposure.	A 10 sec. delay is built in between each exposure. Release the exposure switch.	There should be a " wait" interval of 50 times the exposure time between successive exposures.
	Exposure time was set and exposure switch was depressed within 3 sec. of the power switch being turned on.		Wait a minimum 3 sec. after the main power switch is turned on before pressing the exposure switch.
E.02	Line voltage was less than 90% of rated voltage.	Release the exposure switch.	If line voltage is less than 90% of rated voltage, correct it by using a step-up transformer (*)
E.03	Line voltage was more than 110% of rated voltage.		If line voltage is less than 110% of rated voltage, correct it by using a step-down transformer (*)
E.04	Excess current during exposure.	Turn off the main power switch and wait for approximately 2 min. Turn on the main power switch again.	Contact customer service
E.05	Tube current at last portion of exposure was less than 3 mA at 4 mA setting or less than 5.25 mA at 7 mA setting.		Conduct the confirmation of tube current described in section 6.
E.06	Tube current at last portion of exposure was more than 5 mA at 4 mA setting or more than 8.75 mA at 7 mA setting.		
E.07	During the exposure, tube current becomes less than 2 mA at 4mA setting or less than 3.5 mA at 7 mA setting.		
E.08	During the exposure, tube current becomes more than 6 mA at 4mA setting or more than 10.5 mA at 7 mA setting.		
E.09	Malfunction of the microcomputer.		
E.10	Exposure switch or exposure circuit had been ON, when main power switch is turned on.		Release all the switches
E.11	Tube current is detected during pre-heating period.	Turn off the main power switch and wait for approximately 2 min. Turn on the main power switch again.	Contact customer service
E.12	Tube current is detected when main power switch is turned on.		

Error Code	Condition	Step to be Taken	Possible Solution
E.22	Failure of electrical communication between the power PCB and timer PCB.	Turn off the main power switch and wait for approximately 2 min. Turn on the main power switch again.	Contact customer service
E.23	Any switch on the sub controller is depressed when the main power switch is turned on. (Except the exposure switch)	Release all the switches	Do not turn on the power while other switch is depressed.

[10] MAINTENANCE

BELRAY II MODEL 097 x-ray unit requires post installation confirmation and periodic maintenance checks to be performed by dealer service personnel. These procedures ensure that the x-ray unit is functioning within the manufacture's specifications and remains in compliance with the Standard.

It is responsibility of the owner of the unit to see that these maintenance checks are done **once every 6 months** and that they are performed by a trained, certified service technician.

The specific instructions to perform these checks are located within the BELRAY II MODEL 097 Installation Manual.

- A. Line voltage confirmation
- B. Tube current confirmation
- C. Inspection of arm and head movement
- D. Mechanical safety
 1. The wall plate should be checked to confirm that it is securely attached to the wall.
 2. The arm mounting bracket should be checked to confirm that it is securely attached to the wall mounting plate. The arm mounting bracket must be level horizontally and vertically.
 3. Check and verify that the horizontal arm is not raising up and out of the arm mounting bracket.
This should be verified routinely by treatment room personnel.

[11] TECHNICAL DATA

1. X-ray tube	Toshiba D-0712 (Stationary Anode)	
a. Focal spot	0.7 mm	
b. Target material	Tungsten	
c. Target angle	16°	
d. Maximum anode heat content	4.3kJ (6kHU)	
2. Maximum x-ray tube assembly heat content	150kJ (210kHU)	
3. Rated peak tube potential	70 kVp	
4. Rated tube current	4 mA / 7 mA selectable	
5. Maximum rated peak tube potential	70 kVp	
6. Rated line voltage	120 V AC, 60Hz , Single Phase, 12 VA (Long term rating) 0.8 kVA (Momentary rating)	
7. Line voltage range	108 V AC ~ 132 V AC	
8. Range of line voltage regulation	0 ~ 3 %	
9. Rated line current.....	6.5 A at 70 kVp, 7 mA	
10. Maximum line current	7.2 A at 70 kVp, 7 mA	
11. Exposure time	0.02 ~ 3.2 sec.(ON and OFF are zero crossed)	
12. Inherent filtration	1.7 mm Al Equivalent	
13. Added filtration	0.5 mm Al	
14. Minimum filtration permanently in useful beam	2.2 mm Al Equivalent at 70 kVp	
15. Nominal roentgen output	4mA	7mA
a. Distal end of regular cone	4.2	7.1 mGy/sec. ± 40 %
b. Distal end of long cone	1.9	3.3 mGy/sec. ± 40 %
(Data obtained by direct measurement in the useful beam)		
16. Nominal electrical output of H. V. Generator.....	0.36kW at 70kVp, 7mA	
17. Cone	Source to skin distance	Field size
a. Regular cone	8 inches (204 mm)	58 mm dia., circular
b. Long cone (option)	12 inches (305 mm)	58 mm dia., circular
18. Maximum symmetrical radiation field	60 mm dia. at distal end of cone	
19. Leakage technique factor	70 kVp / 0.14 mA (0.14 mA is maximum rated continuous current for 7 mA with a duty cycle 1: 50)	
20. Duty cycle	1: 50 (0.5 sec. exposure with 25 sec. interval)	
21. Maximum deviation of tube potential, tube current and exposure time		
a. Below 0.1sec. setting	± 10 kVp, ± 2 mA, ± 1pulse	
b. 0.1sec. setting & up	± 8 kVp, ± 1 mA, ± 1pulse	
22. Measurement base of technique factors		
a. peak tube potential	Peak tube potential of conducting half cycle	
b. tube current	Average of tube current during one cycle of line frequency	
c. exposure time	Impulses of power line frequency	
23. Half value layer	1.5 mm Al over	
24. Source to the base of cone distance	81 mm	
25. Environmental condition for storage	-20 ~ 70°C, 10 ~ 100%, 500 ~ 1060hPa	
26. Environmental condition for operation	10 ~ 40°C, 30 ~ 70%, 700 ~ 1060hPa	

[12] ELECTROMAGNETIC COMPATIBILITY(EMC)

Medical electrical equipment needs special precautions regarding EMC and needs to be installed and put into service according to the EMC information provided in this manual.

Portable and mobile RF communications equipment can affect medical electrical equipment. The equipment or system should not be used adjacent to or stacked with other equipment. If adjacent or stacked use is necessary, the equipment or system should be observed to verify normal operation in the configuration in which it will be used.

Guidance and manufacture's declaration – electromagnetic emissions		
The BELRAY II MODEL 097 x-ray is intended for use in the electromagnetic environment specified below. The customer or the user of the BELRAY II MODEL 097 x-ray should assure that it is used in such an environment.		
Emissions test	Compliance	Electromagnetic environment - guidance
RF emissions CISPR 11	Group 1	The BELRAY II MODEL 097 x-ray uses RF energy only for its internal function. Therefore, its RF emissions are very low and are not likely to cause any interference in nearby electronic equipment.
RF emissions CISPR 11	Class A	The BELRAY II MODEL 097 x-ray is suitable for use in all establishments other than domestic and those directly connected to the public low-voltage power supply network that supplies buildings used for domestic purposes.
Harmonic emissions IEC 61000-3-2	Not applicable	
Voltage fluctuations/ Flicker emissions IEC 61000-3-3	Not applicable	

Guidance and manufacture's declaration – electromagnetic immunity			
The BELRAY II MODEL 097 x-ray is intended for use in the electromagnetic environment specified below. The customer or the user of the BELRAY II MODEL 097 x-ray should assure that it is used in such an environment.			
Immunity test	IEC 60601 test level	Compliance level	Electromagnetic environment - guidance
Electrostatic discharge (ESD) IEC 61000-4-2	±6 kV contact ±8 kV air	±6 kV contact ±8 kV air	Floors should be wood, concrete or ceramic tile. If floors are covered with synthetic material, the relative humidity should be at least 30%.
Electrical fast transient/burst IEC 61000-4-4	±2 kV for power supply lines ±1 kV for input/output lines	±2 kV for power supply lines ±1 kV for input/output lines	Mains power quality should be that of a typical commercial or hospital environment.
Surge IEC 61000-4-5	±1 kV differential mode ±2 kV common mode	±1 kV differential mode ±2 kV common mode	Mains power quality should be that of a typical commercial or hospital environment.
Voltage dips, short interruptions and voltage variations on power supply input lines IEC 61000-4-11	<5% U_T (>95% dip in U_T) for 0.5 cycle 40% U_T (60% dip in U_T) for 5 cycle 70% U_T (30% dip in U_T) for 25cycle <5% U_T (>95% dip in U_T) for 5 s	<5% U_T (>95% dip in U_T) for 0.5 cycle 40% U_T (60% dip in U_T) for 5 cycle 70% U_T (30% dip in U_T) for 25cycle <5% U_T (>95% dip in U_T) for 5 s	Mains power quality should be that of a typical commercial or hospital environment. If the user of the BELRAY II MODEL 097 x-ray requires continued operation during power mains interruptions, it is recommended that the BELRAY II MODEL 097 x-ray be powered from an uninterruptible power supply or a battery.
Power frequency (50/60 Hz) magnetic field IEC 61000-4-8	3 A/m	0.3 A/m	Power frequency magnetic fields should be at levels characteristic of a typical location in a typical commercial or hospital environment.
NOTE U_T is the a.c. mains voltage prior to applications of the test level.			

Guidance and manufacture's declaration – electromagnetic immunity

The BELRAY II MODEL 097 x-ray is intended for use in the electromagnetic environment specified below. The customer or the user of the BELRAY II MODEL 097 should assure that it is used in such an environment.

Immunity test	IEC 60601 test level	Compliance level	Electromagnetic environment - guidance
Conducted RF IEC 61000-4-6	3 Vrms 150 kHz to 80 MHz outside ISM bands ^a	3 Vrms	Portable and mobile RF communications equipment should be used no closer to any part of the BELRAY II MODEL 097 x-ray, including cables, than the recommended separation distance calculated from the equation applications to the Frequency of the transmitter. Recommended separation distance $d = 1.2\sqrt{P}$
Radiated RF IEC 61000-4-3	3V/m 80 MHz to 2.5 GHz	3 V/m	$d = 1.2\sqrt{P}$ 80 MHz to 800 MHz $d = 2.3\sqrt{P}$ 800 MHz to 2.5 GHz Where P is the maximum output power rating of the transmitter in watts (W) according to the transmitter manufacturer and d is the recommended separation distance in metres (m). Field strengths from fixed RF transmitters, as determined by an electromagnetic site survey, ^a should be less than the compliance level in each frequency range. ^b Interference may occur in the vicinity of equipment marked with the following symbol: 

NOTE 1 At 80 MHz and 800MHz, the higher frequency range applies.

NOTE 2 These guidelines may not apply in all situations. Electromagnetic propagation is affected by adsorption and reflection from structures, objects and people.

a Field strengths from fixed transmitters, such as base stations for radio (cellular/cordless) telephones and land mobile radios, amateur radio, AM and FM radio broadcast and TV broadcast cannot be predicted theoretically with accuracy. To assess the electromagnetic environment due to fixed RF transmitters, an electromagnetic site survey should be considered. If the measured field strength in the location in which the BELRAY II MODEL 097 x-ray is used exceeds the applicable RF compliance level above, the BELRAY II MODEL 097 x-ray should be observed to verify normal operation. If abnormal performance is observed, additional measures may be necessary, such as reorienting or relocating the BELRAY II MODEL 097 x-ray.

b Over the frequency range 150 kHz to 80 MHz, field strengths should be less than 3V/m.

Essential performance (purpose of IMMUNITY testing)

Unless the exposure switch is pressed, x-ray is not exposed.

**Recommended separation distances between
Portable and mobile RF communications equipment and the BELRAY II MODEL 097 x-ray**

The BELRAY II MODEL 097 x-ray is intended for use in an electromagnetic environment in which radiated RF disturbances are controlled. The customer or the user of the BELRAY II MODEL 097 x-ray can help prevent electromagnetic interference by maintaining a minimum distance between portable and mobile RF communications equipment (transmitters) and the BELRAY II MODEL 097 x-ray as recommended below, according to the maximum output power of the communications equipment.

Rated maximum output power of transmitter W	Separation distance according to frequency of transmitter m		
	150 kHz to 80 MHz $d = 1.2\sqrt{P}$	80 MHz to 800 MHz $d = 1.2\sqrt{P}$	800 MHz to 2.5 GHz $d = 2.3\sqrt{P}$
0.01	0.12	0.12	0.23
0.1	0.38	0.38	0.73
1	1.2	1.2	2.3
10	3.8	3.8	7.3
100	12	12	23

For transmitters rated at a maximum output power not listed above, the recommended separation distance d in metres (m) can be estimated using the equation applicable to the frequency of the transmitter, where P is the maximum output power rating of the transmitter in watts (W) according to the transmitter manufacturer.

NOTE 1 At 80 MHz and 800MHz, the separation distance for the higher frequency range applies.

NOTE 2 These guidelines may not apply in all situations. Electromagnetic propagation is affected by adsorption and reflection from structures, objects and people.

NOTE



BELMONT EQUIPMENT, Division of Takara Belmont, USA, Inc.

101 Belmont Drive Somerset, New Jersey 08873 U.S.A. TEL.:(732) 469-5000 / (800) 223-1192 Fax.:(732)526-6322 / (800) 280-7504
www.belmonteqip.com

TAKARA CO, CANADA LTD.

2076 S. Sheridan Way, Mississauga, Ont., L5J2M4, Can. TEL.:(905) 822-2755 Fax.:(905)822-6203
www.takarabelmont.ca