

Quolis[®] Series

Quolis 5000 Light

Model AL-820

INSTALLATION AND OPERATION INSTRUCTIONS

IMPORTANT

After installation is completed, check all the bolts, screws and fasteners to confirm that they are securely fastened.

 **Belmont[®]**

TABLE OF CONTENTS

	Page
[1] MAJOR PARTS IDENTIFICATION -----	1
[2] SPECIFICATIONS -----	1
[3] CLASSIFICATION -----	1
[4] WIRING DIAGRAM -----	2
[5] DIMENSIONS -----	2
[6] INSTALLATION	
6-1. Attach the light assembly to the light pole -----	3
6-2. Feed the light assembly wire harness through the swing arm-----	3
6-3. Attach the switch box -----	3
6-4. Attaching wire harness from light assembly, transformer assembly and the switch box -----	4
6-5. Attach the switch box cover -----	5
6-6. Wiring between Switch box and transformer assembly -----	5
[7] OPERATION	
7-1. Mode selection switch -----	7
7-2. Operation of the touch-less switch -----	7
[8] ADJUSTMENT OF THE BALANCE ARM	
8-1. Adjustment of the tension of the balance arm-----	8
8-2 Adjustment of the angle of the light head -----	8
[9] REPLACEMENT OF THE BULB	
9-1. Removal of the reflector cover -----	9
9-2. Replacement of the bulb -----	9
9-3. Inserting a new bulb -----	10
9-4. Attaching the reflector cover -----	10
[10] CLEANING -----	11

Intended Use of the Product

This product is intended for the exclusive use for diagnoses, treatments and relative procedures of dentistry, and must be operated or handled by the qualified dentists or by dental staffs under the supervision of the dentist. Such dentists or dental staffs should instruct and/or assist the patients to approach to and leave from the product. Patients should not be allowed to operate or handle the product unless he/she is so instructed.

Environmental Requirements

Ambient Temperature	Operating 41F - 104F	Storage 14F - 122F
Humidity	10 % - 80%	
Atmospherical Pressure	8.7 psi - 15.4 psi	

[1] MAJOR PARTS IDENTIFICATION

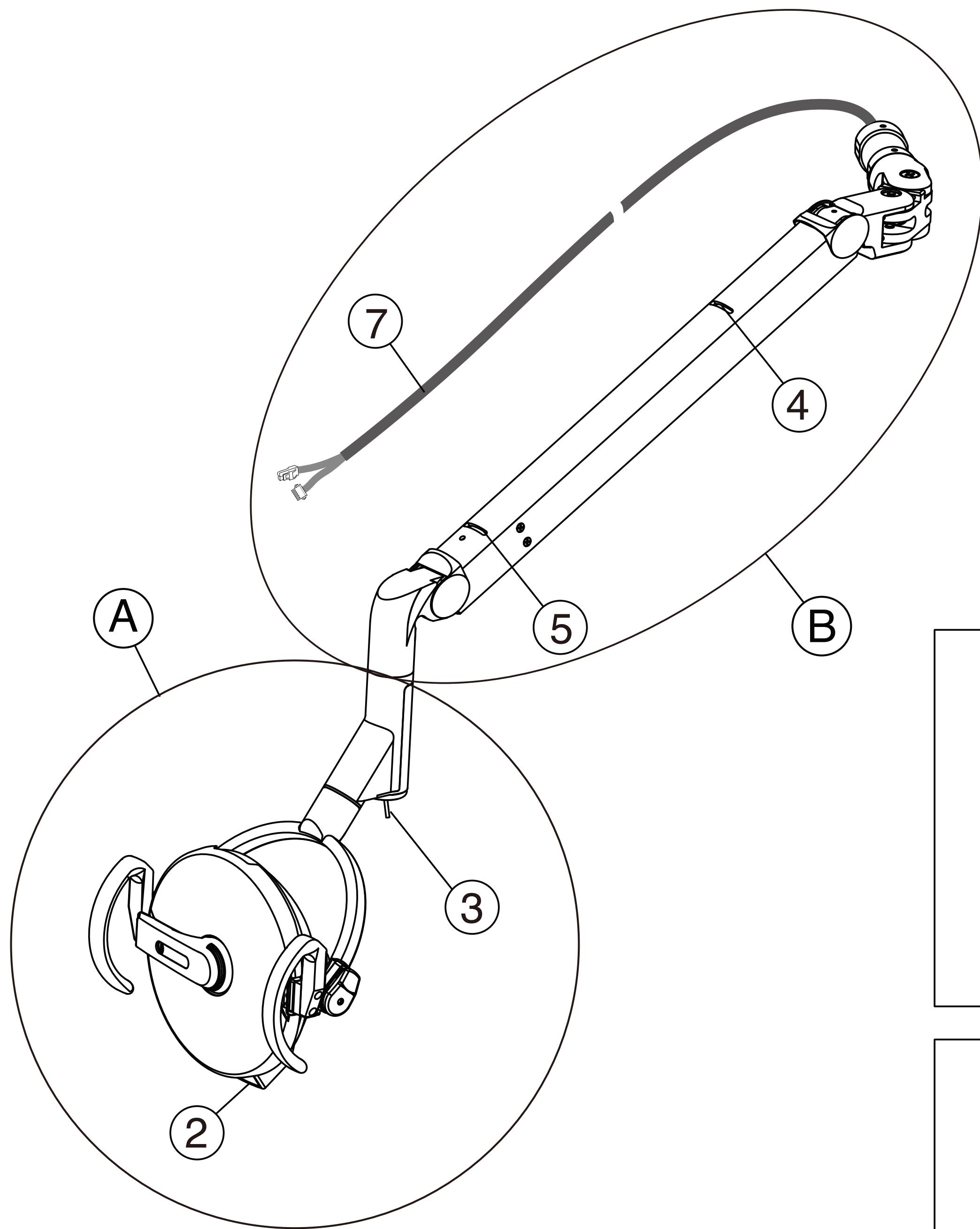

(A) Head assembly

(B) Balance arm assembly

1. Mode selection switch
2. Touchless Switch
3. Intensity Switch
4. Slot A for Adjusting Tension of Balance Arm
5. Slot B for Adjusting Angle of Head
6. Transformer assembly
7. Light assembly wire harness
8. Transformer wire harness

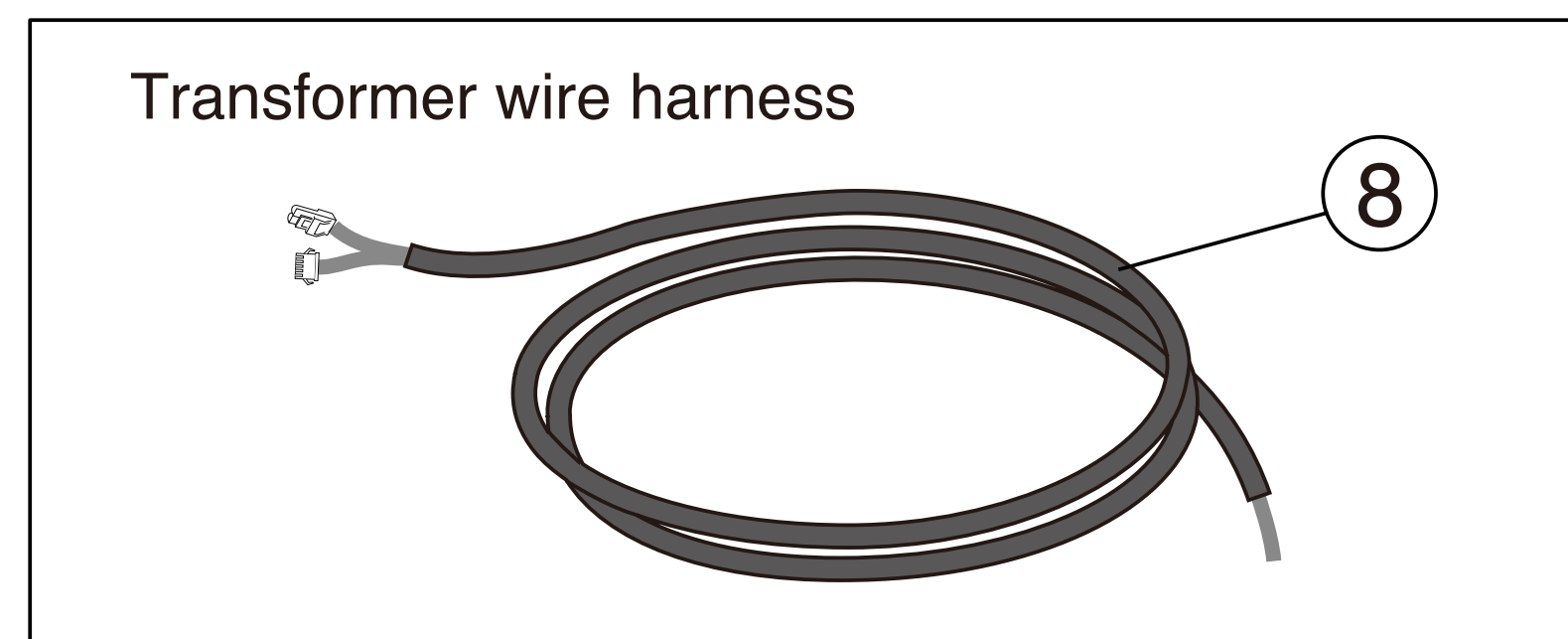
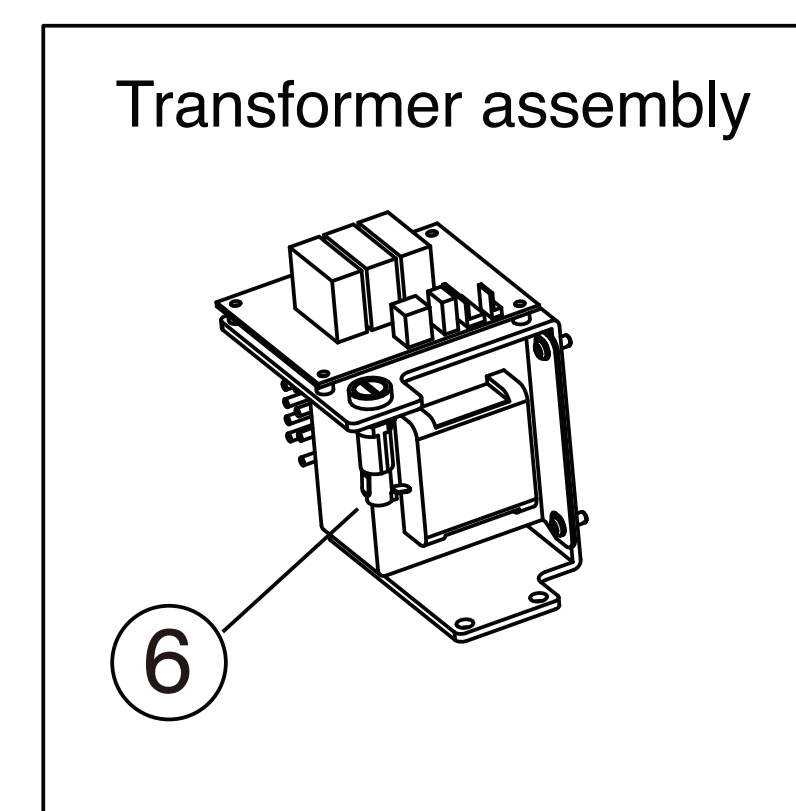
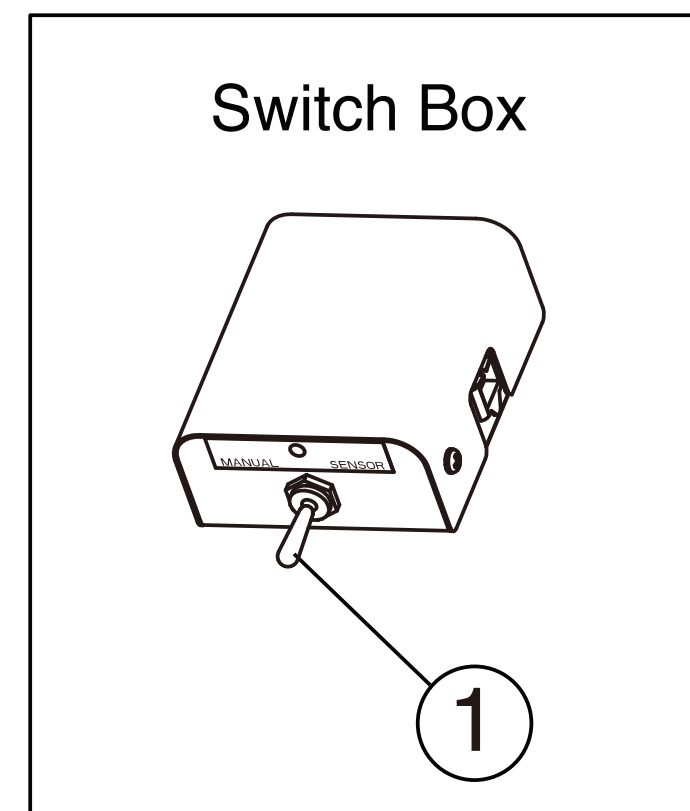

[2] SPECIFICATIONS

1. Focal Distance	27.5"
2. Color Temperature	5000°C Kelvin at 28,000 Lux / 2600 FTC
3. Light Intensity.....	H : 28,000 Lux / 2600 FTC M : 22000 Lux / 2000 FTC L : 8000 Lux / 740 FTC
4. Light Pattern	2.4" x 6.7" at 27.5"
5. Power Requirement	AC. 100/115/120V 50/60 Hz
6. Bulb Type.....	Tungsten Halogen Type (JA 24V 60W)

[3] CLASSIFICATION

- a. Protection against electric shock : Class I Equipment, Type B Applied Parts
- b. Equipment not suitable for use in the presence of a flammable anesthetic mixture with air or with oxygen or nitrous oxide.

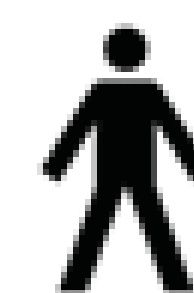

[4] WIRING DIAGRAM

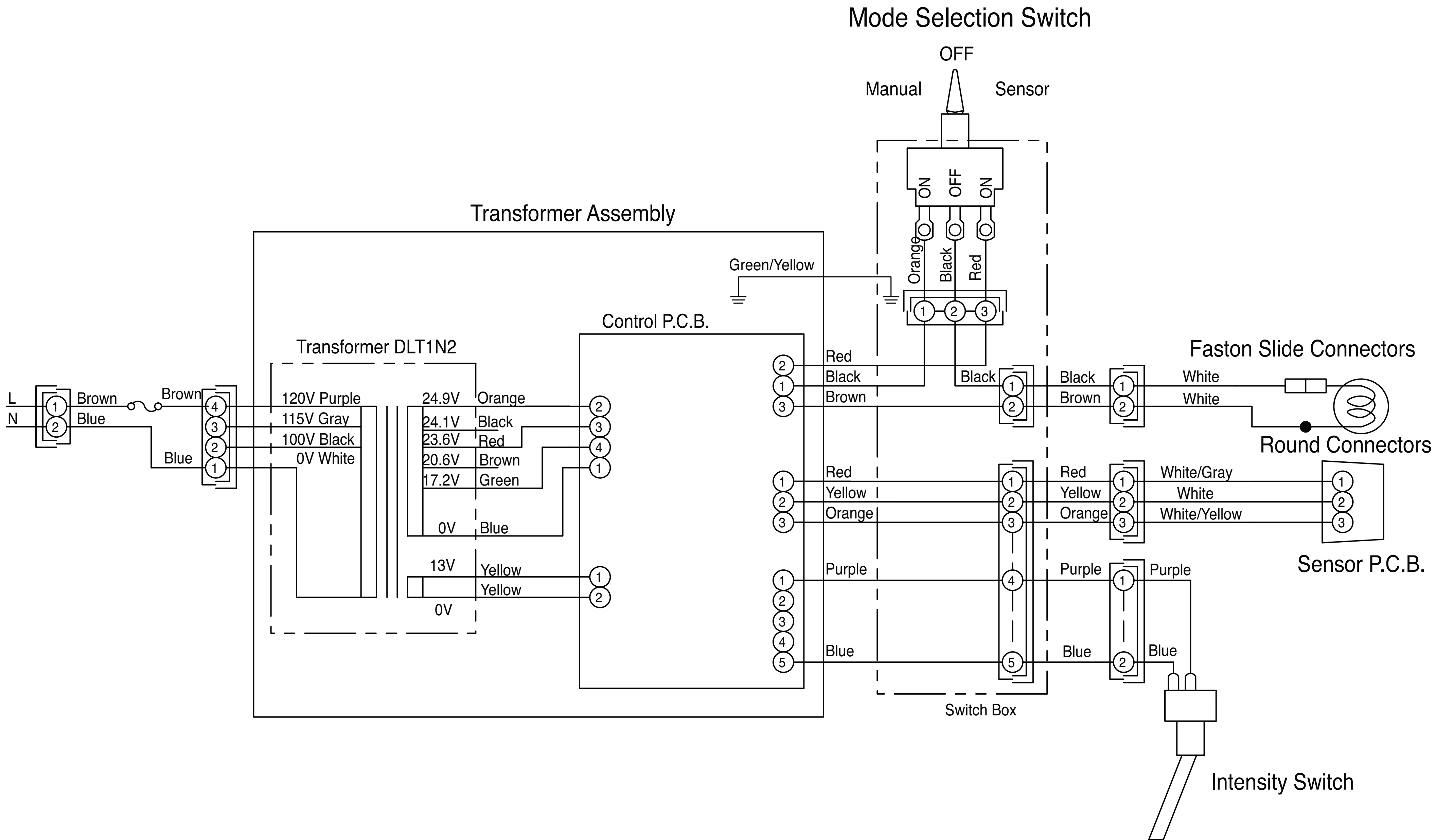

[5] DIMENSIONS

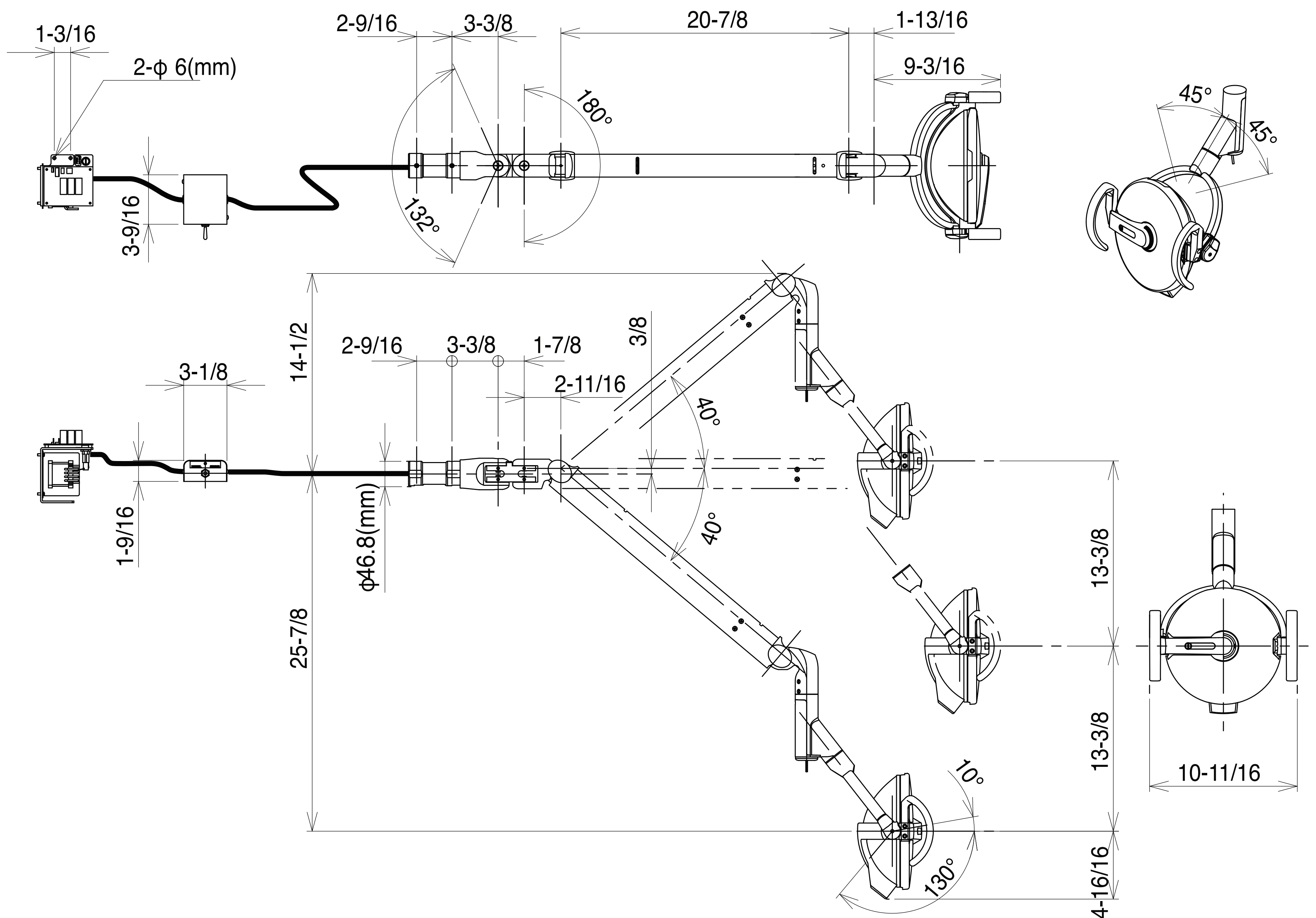

[6] INSTALLATION

6-1. Attach the light assembly to the light pole

Feed the wire harness coming from the balance arm joint through the light pole. Insert the balance arm joint of the light into the light pole. Fasten with two M6 x 12mm screws.

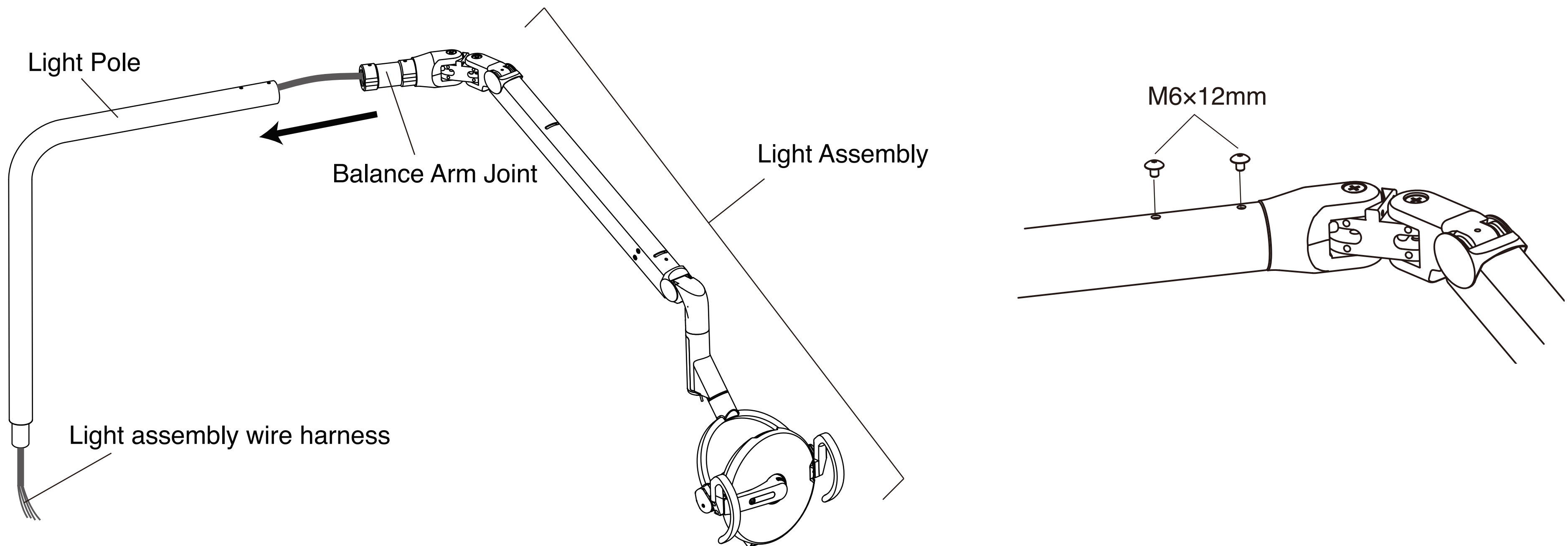

6-2. Feed the light assembly wire harness through the swing arm

Feed the light assembly wire harness through the swing arm and pull the end of the harness from the lower end of the swing arm. Mount the light assembly onto swing arm.

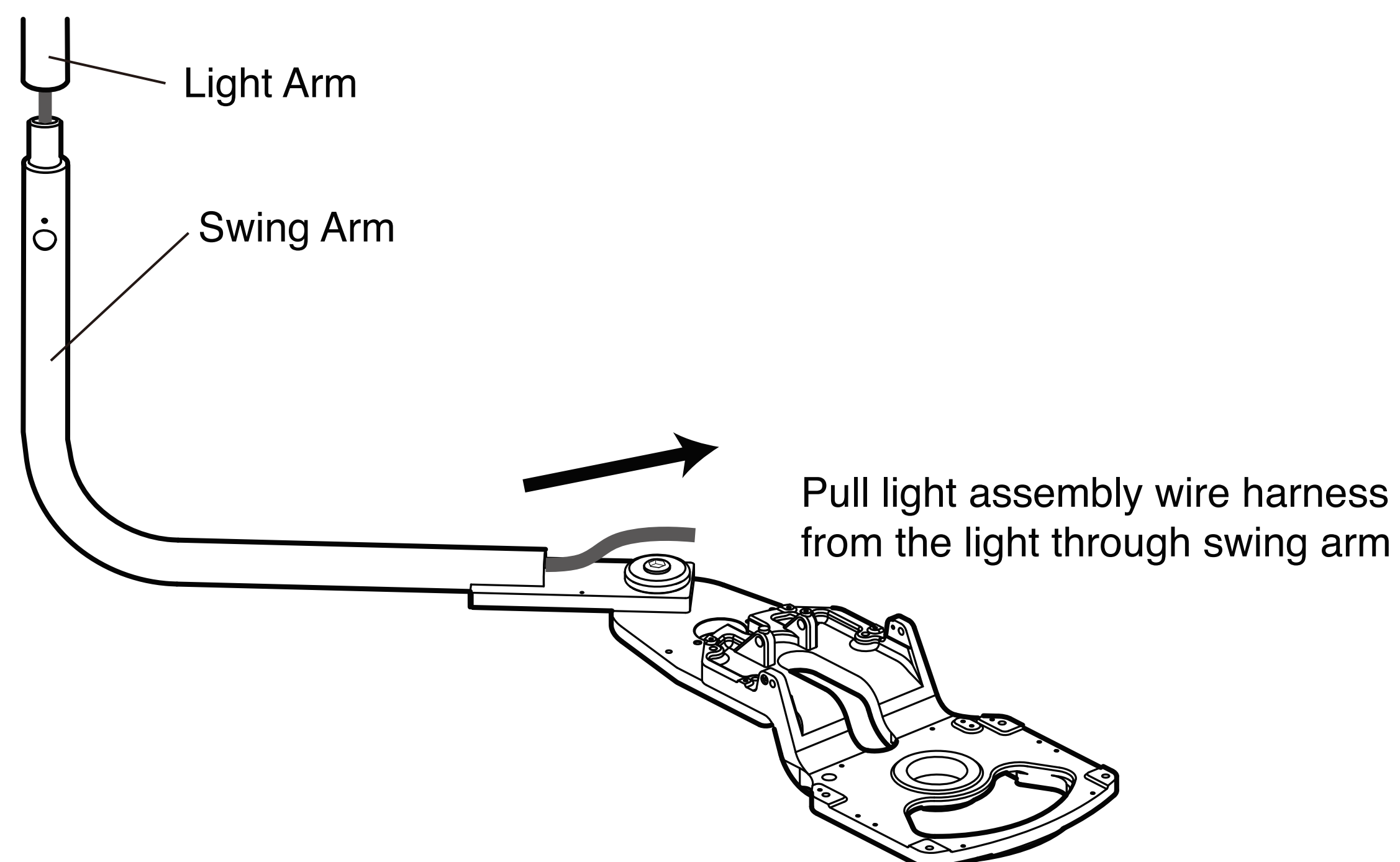

6-3. Attach the switch box

Attach the switch box onto the swing arm with two screws M4 x 8mm.

Fix the Green/Yellow line from transformer wire harness together with same screw as shown in figure.

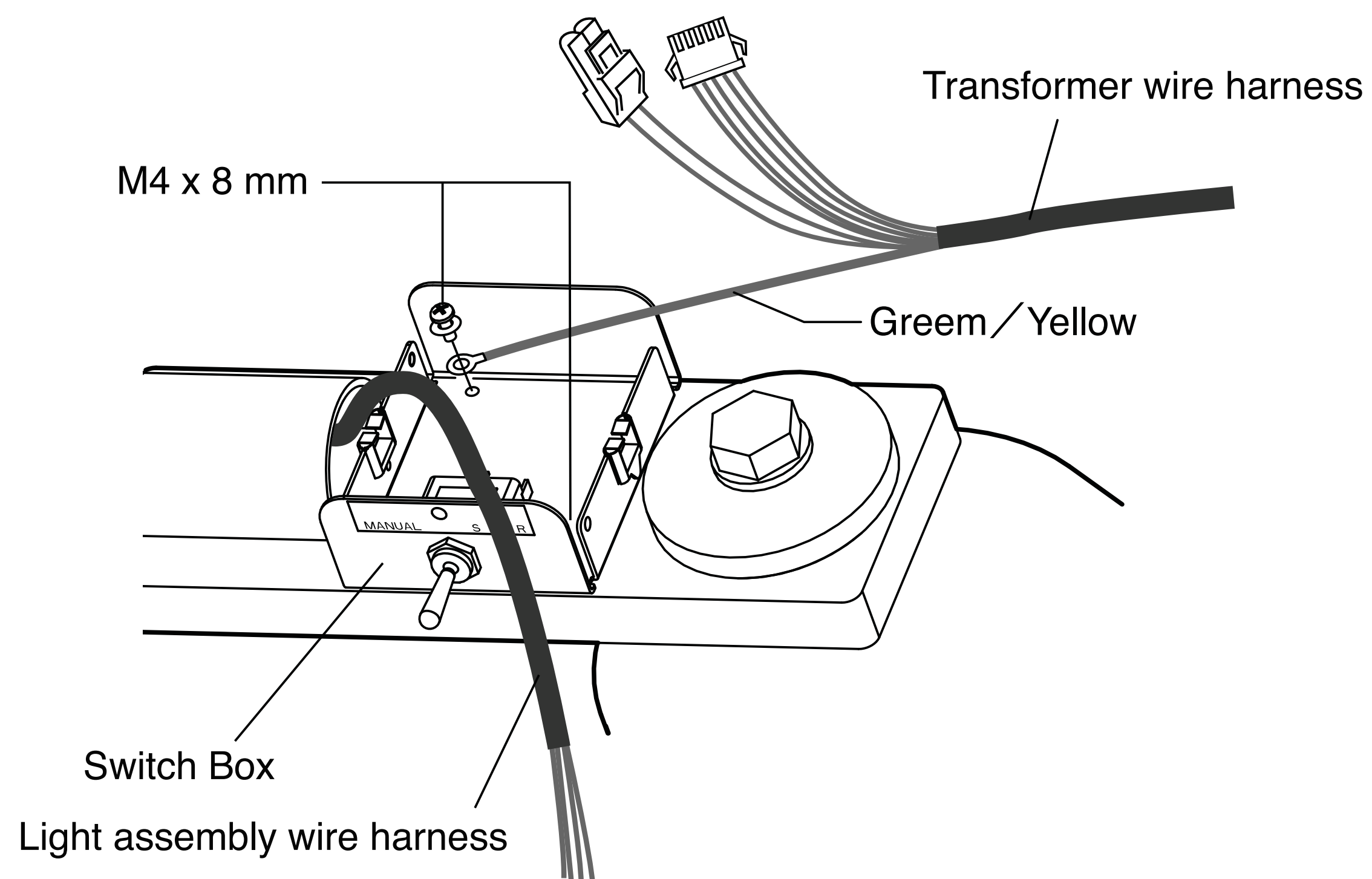

6-4. Attaching wire harness from light assembly, transformer assembly and the switch box

(1) Attach the connectors of the light assembly wire harness and transformer wire harness.

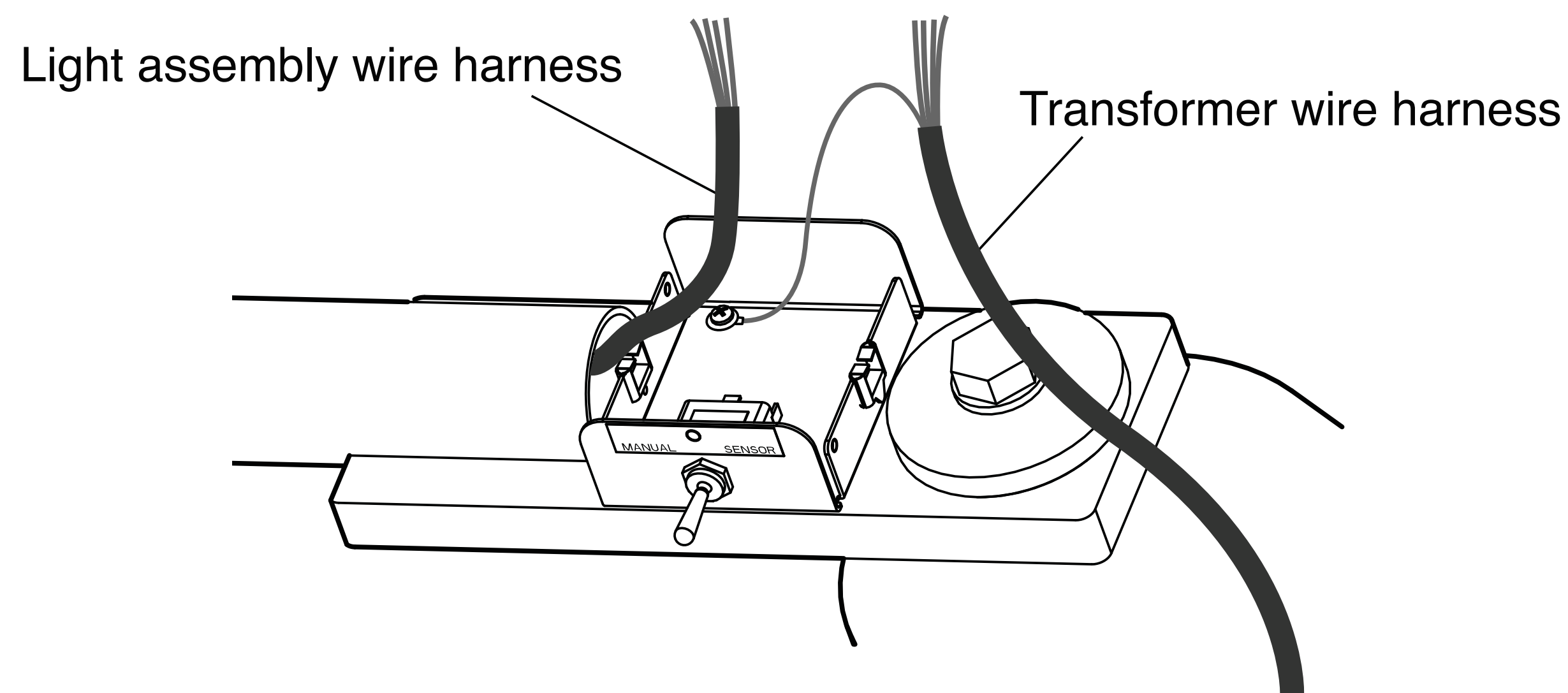

(2) As illustrated below, place the wire harness inside the guide. The part with the cable tie should be inside the box. Lead all the wires underneath the switch, and connect the connectors (3 pins) from the transformer wire harness and the mode selection switch. See [2] Wiring diagrams.

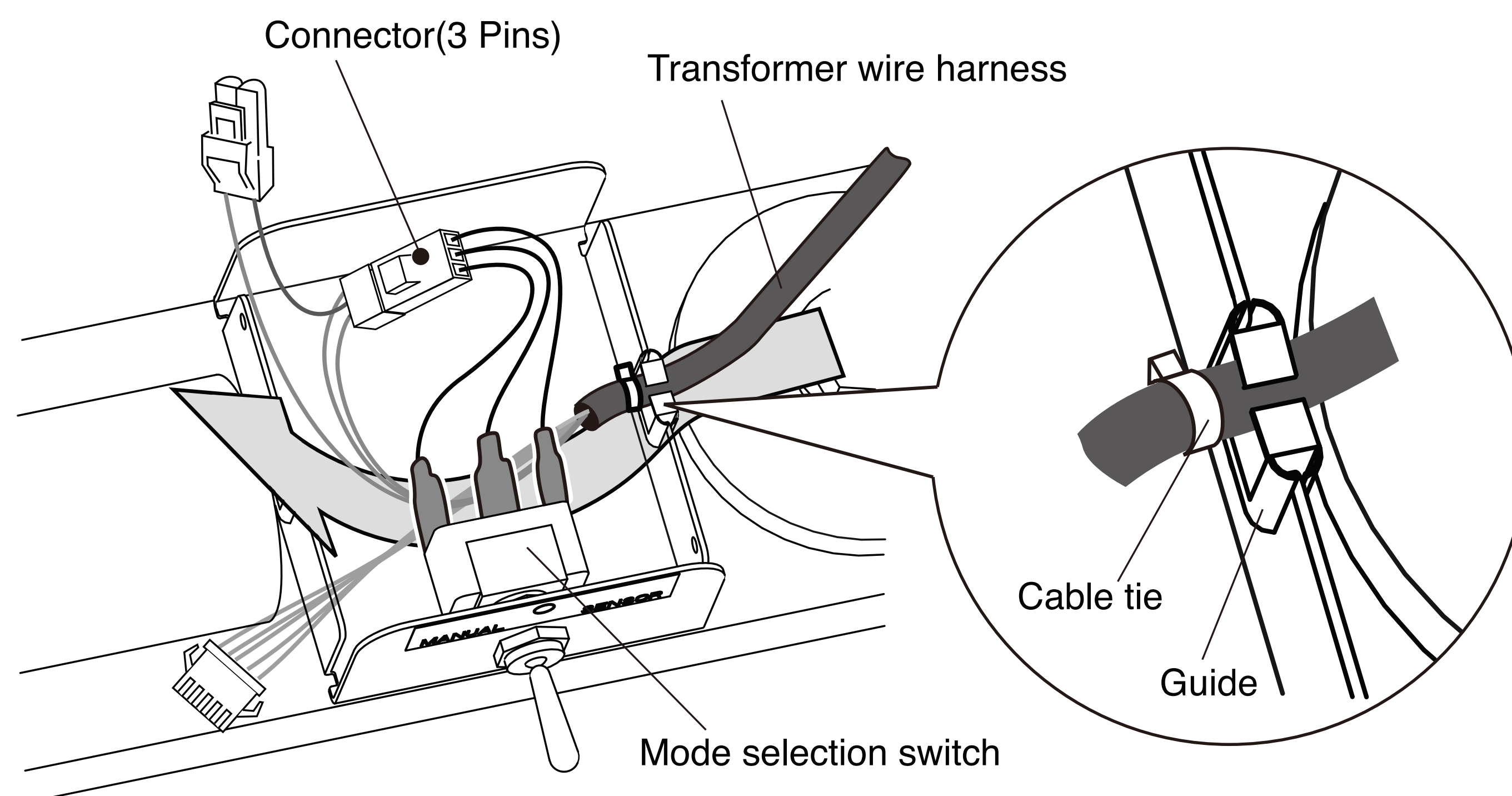

(3) As illustrated below, place the Light Assembly Wire Harness inside the cable guide. The part with the cable tie should be inside the box. Make sure that the Light Assembly Wire Harness should be above that from the transformer assembly.

Connect the connectors (5 pins) of the wire harnesses.

Also connect connectors (2 pins) of the wire harnesses.

See [2] Wiring diagrams.

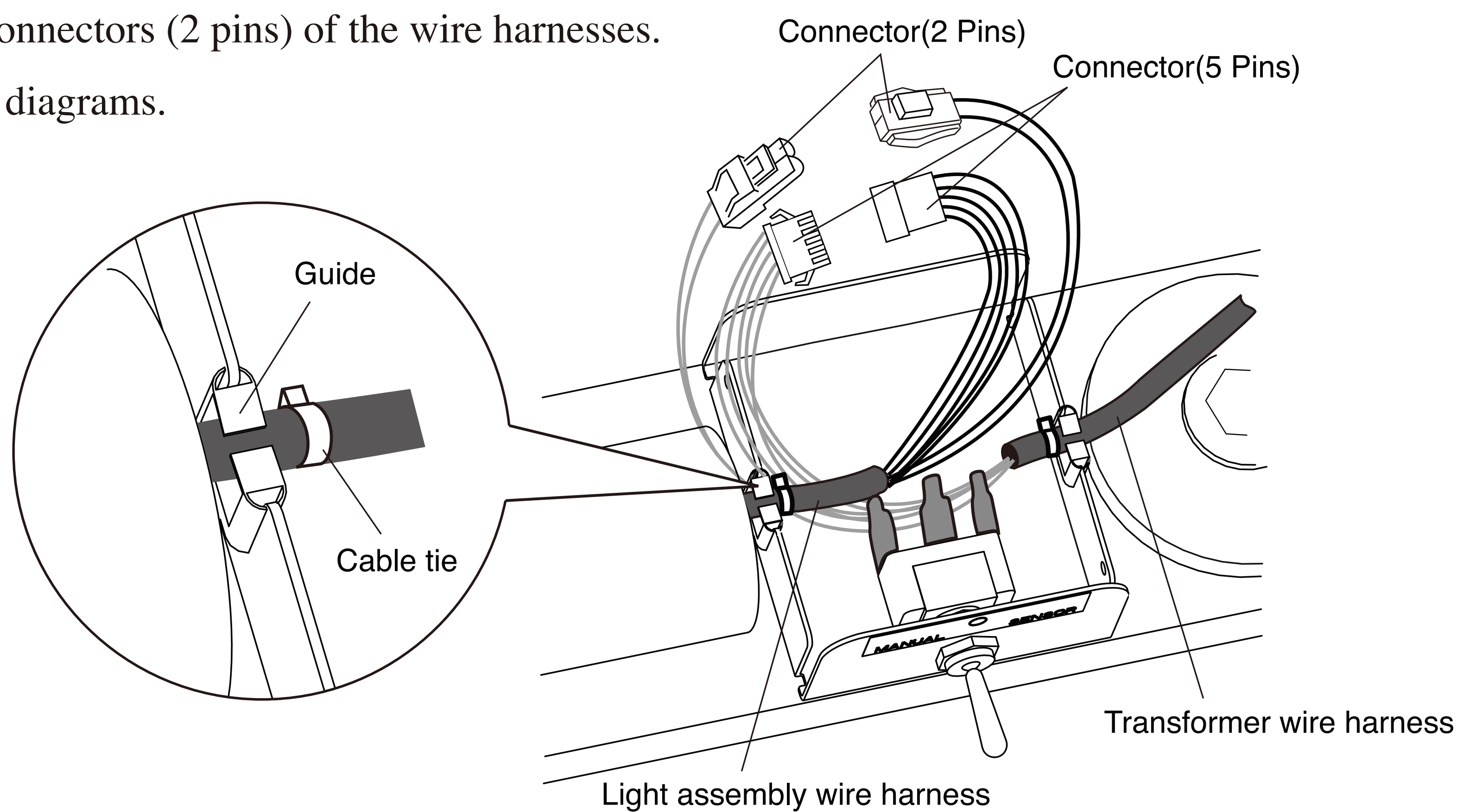

6-5. Attach the switch box cover

Put all the wires inside the box. Place the switch box cover on the switch box and fix it with two M4 x 6mm screws.

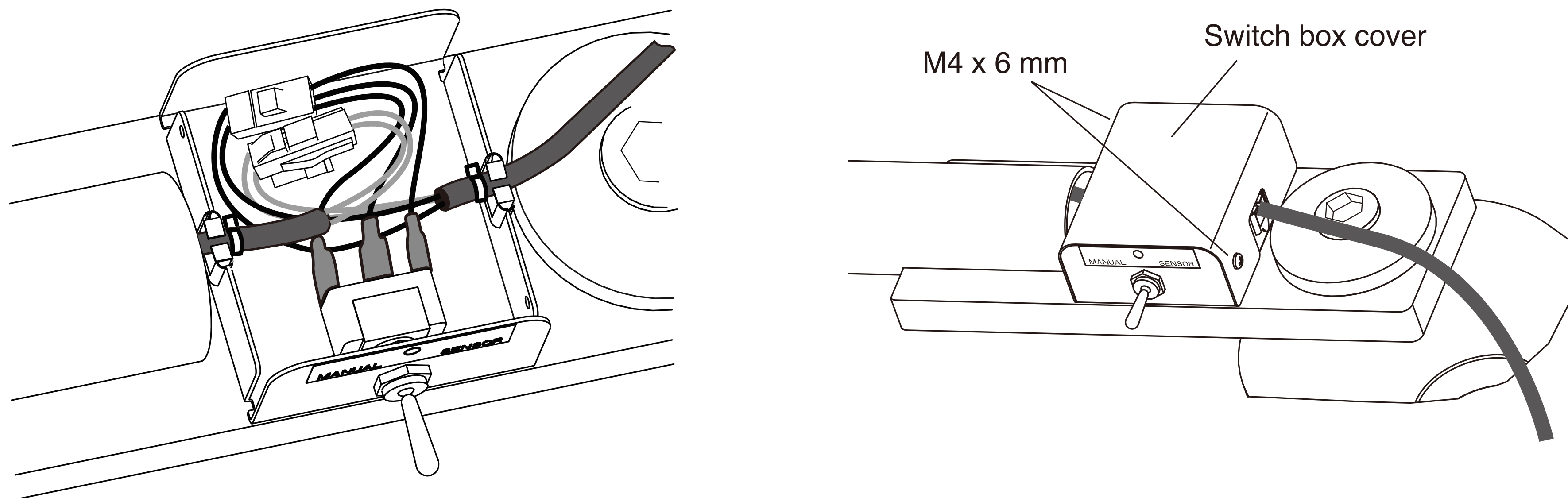

6-6. Wiring between Switch box and transformer assembly

(1) Insert the wire harness down through the hole of the swing arm bracket.

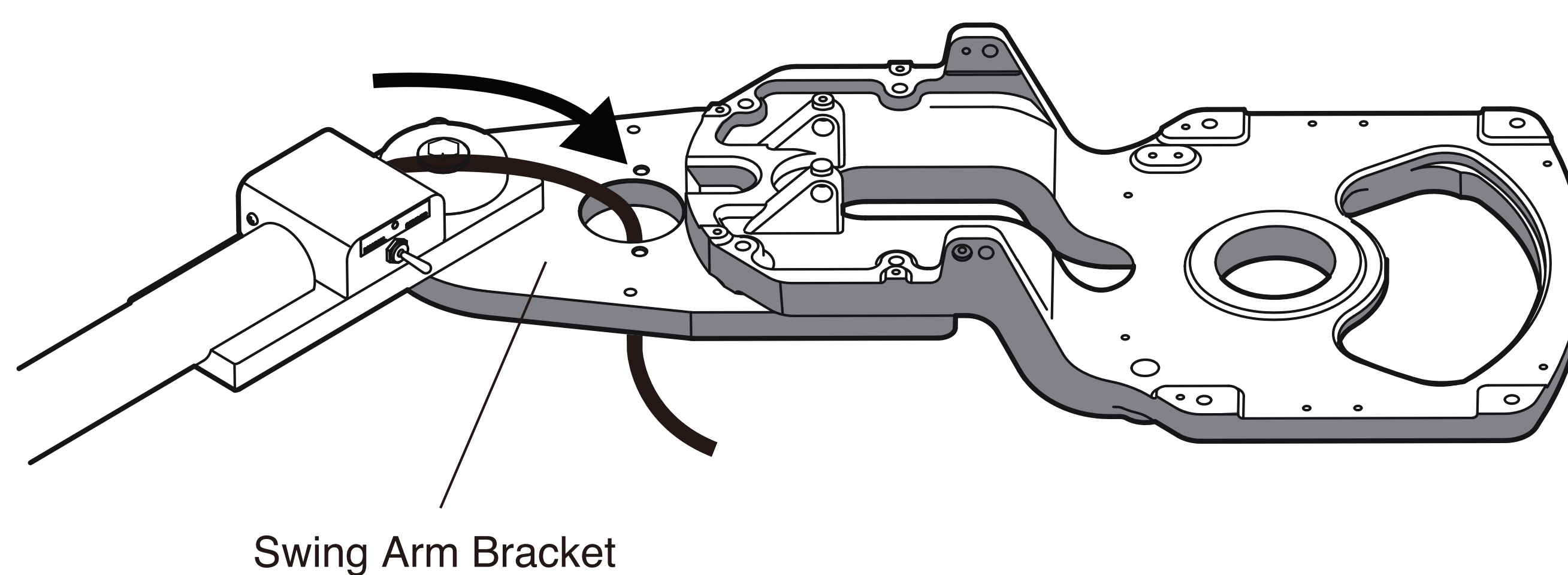

(2) Feed the wire harness through the flange parts as below ① and link part as below ② of the chair to the pump cover part along the same path as the cables and tubing of the doctor's table.

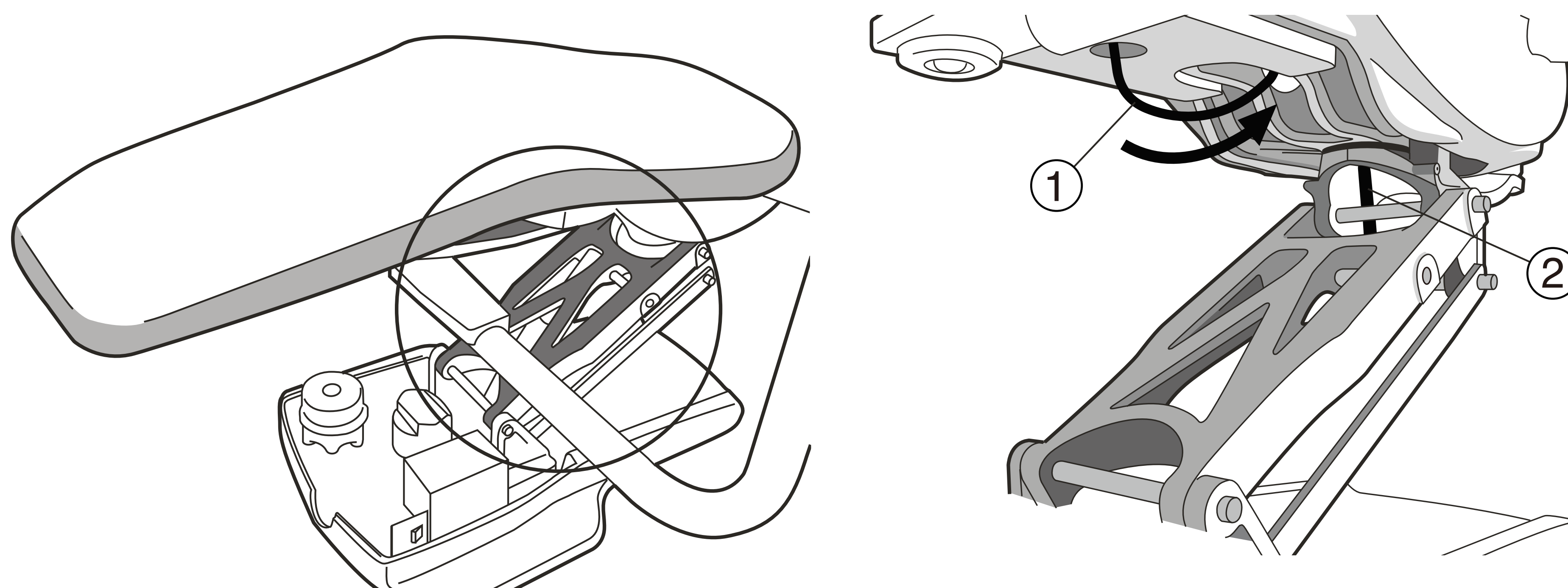

(3) Attach the transformer assembly by the motor pump of the chair with two M5 x 12mm screws.

Also fix the Green/Yellow line from transformer wire harness together with same screw.

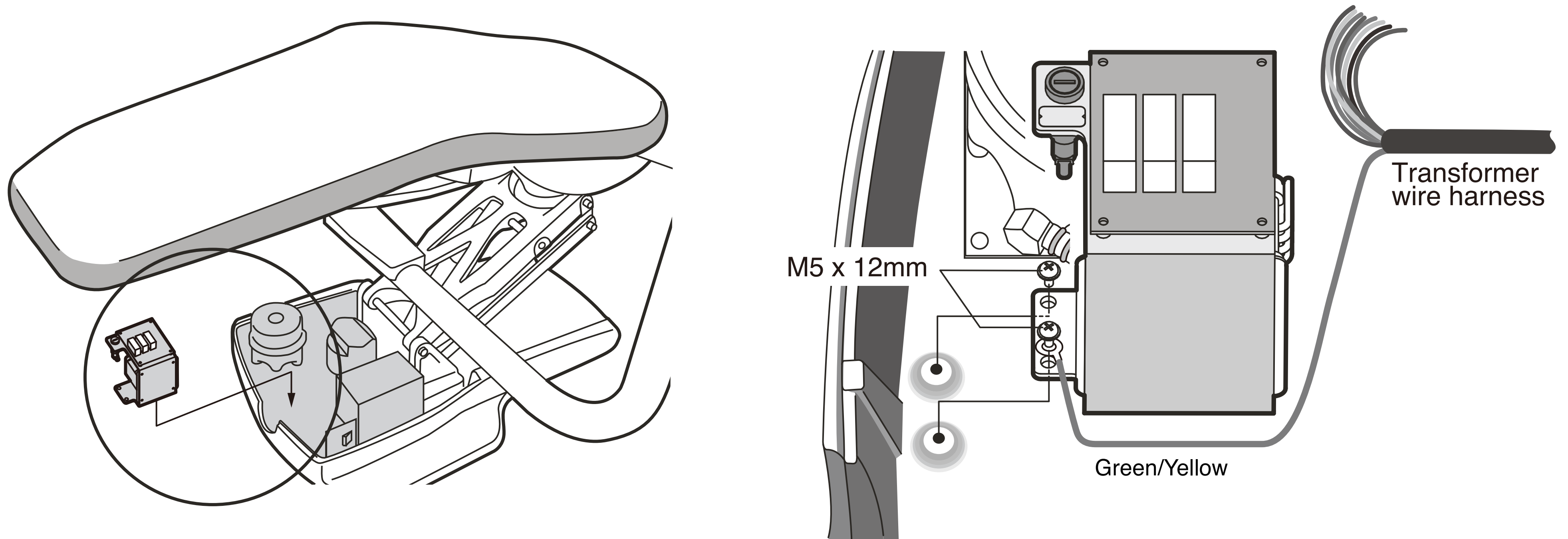

(4) Attach the connectors onto the control PCB of the transformer assembly.

Connection with the wire harness for the switch box : 3 pins, 3 pins, 5 pins

Connection with the chair's control PCB : 2 pins

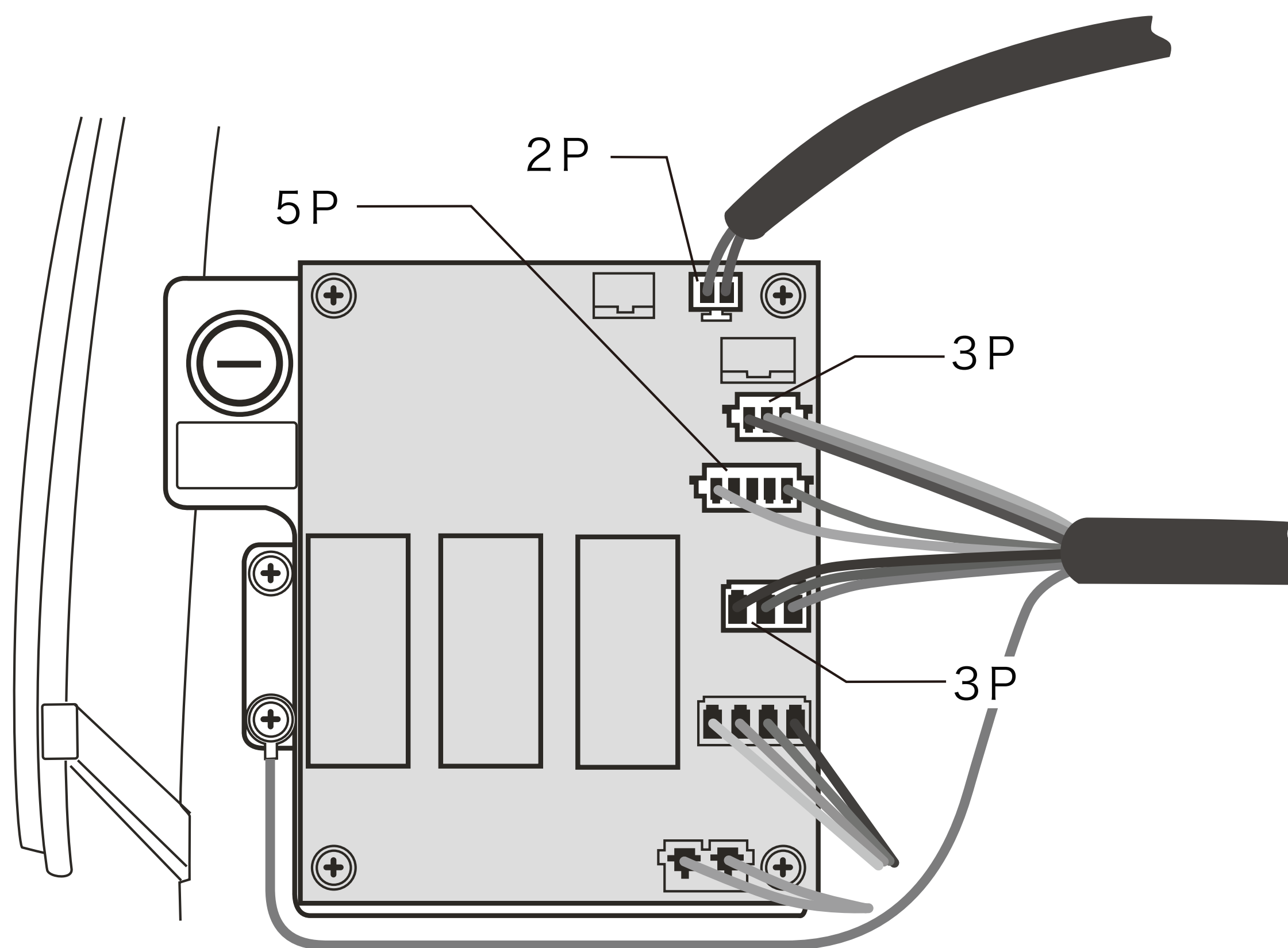

(5) Connect the power cable of the transformer to the connector on the metallic box inside the junction box.

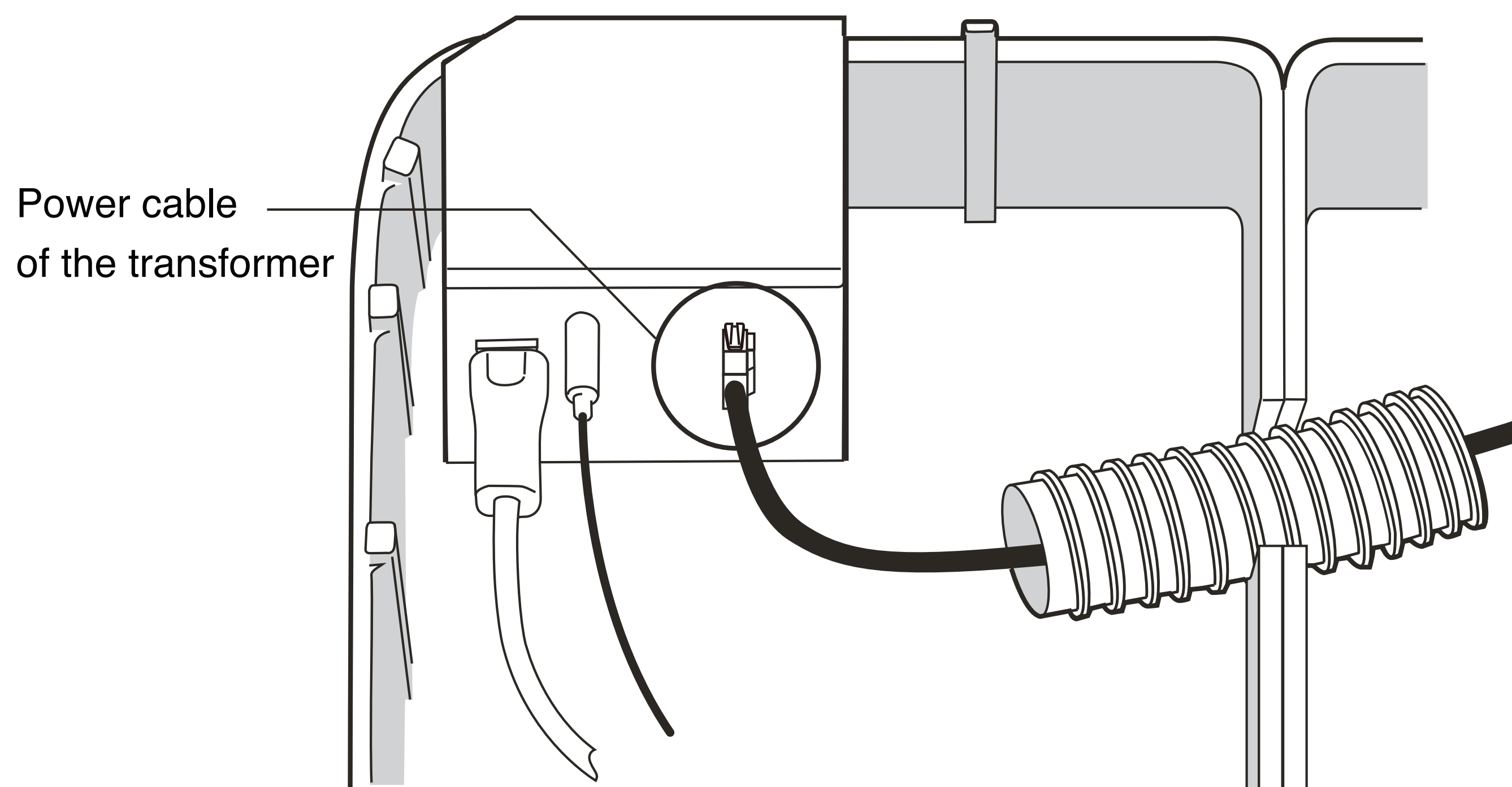

[7] OPERATION

7-1. Mode Selection switch

Select the desired - sensor or manual mode with the switch on the box.

Sensor : In this mode, the light can be turned on or off with the touch-less switch.

Manual : The light is switched on at high intensity (2600FTC/28000 lux).

○ : off

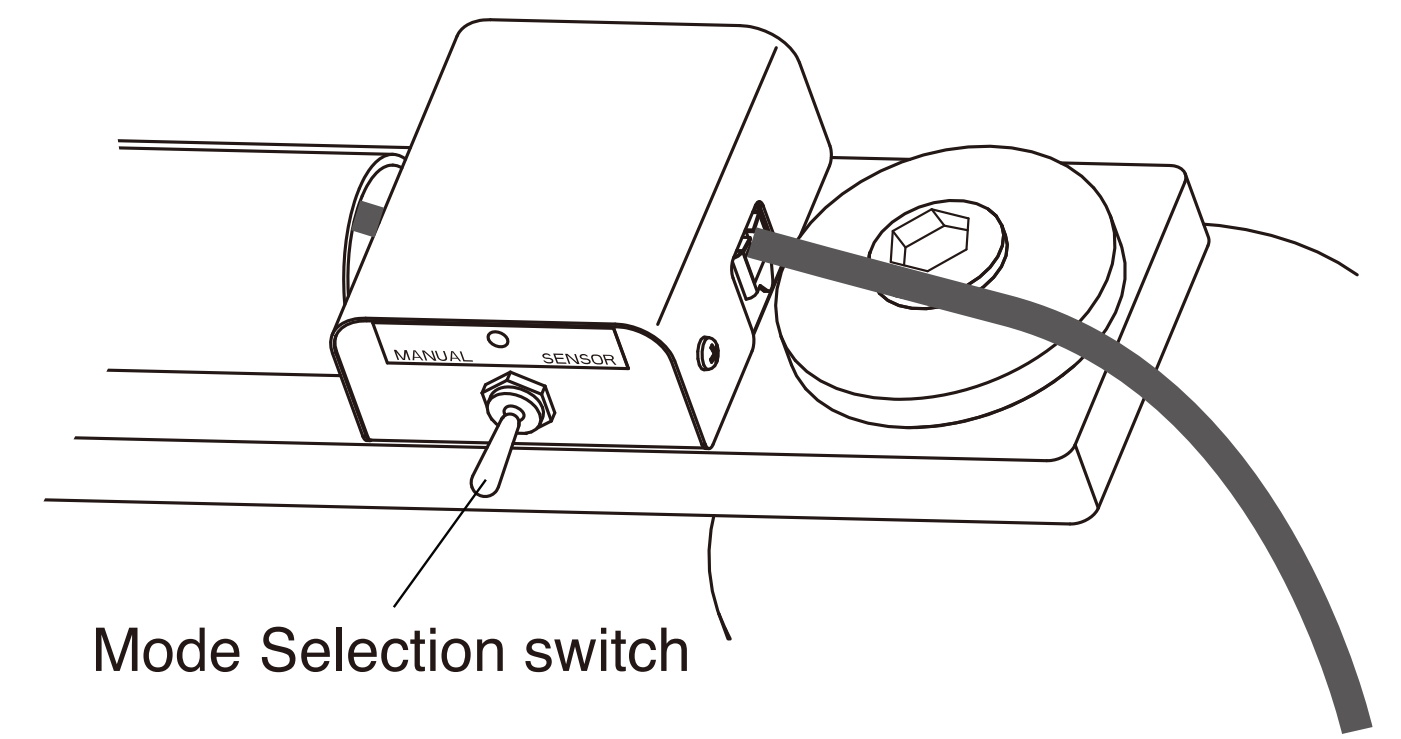

7-2. Operation of the touch-less switch

The light can be turned on/off with a touch-less sensor switch.

The intensities are High, Low and Composite mode.

7-2-1. Confirmation of mode selection switch

Make sure that the mode selection switch is at Sensor mode.

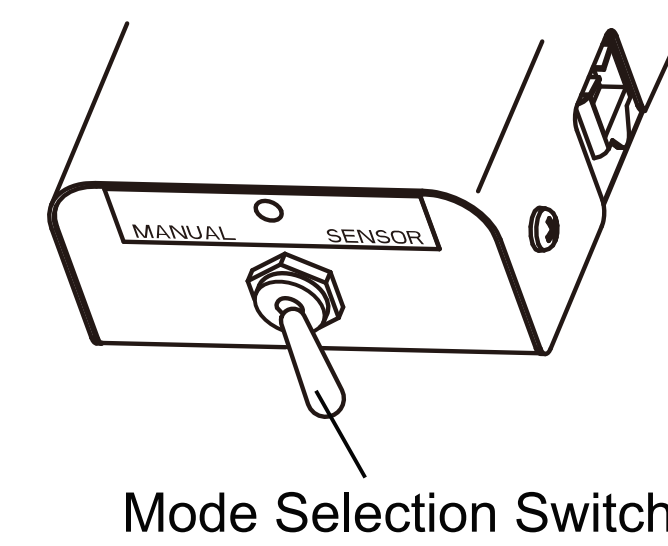

7-2-2. Turning on/off

The touch-less switch has a sensor. The sensor activates within the distance of 2-1/2 " from the surface. Let your hand pass by within 2-1/2 " from the sensor to turn on the light.

Let your had pass by again to turn off.

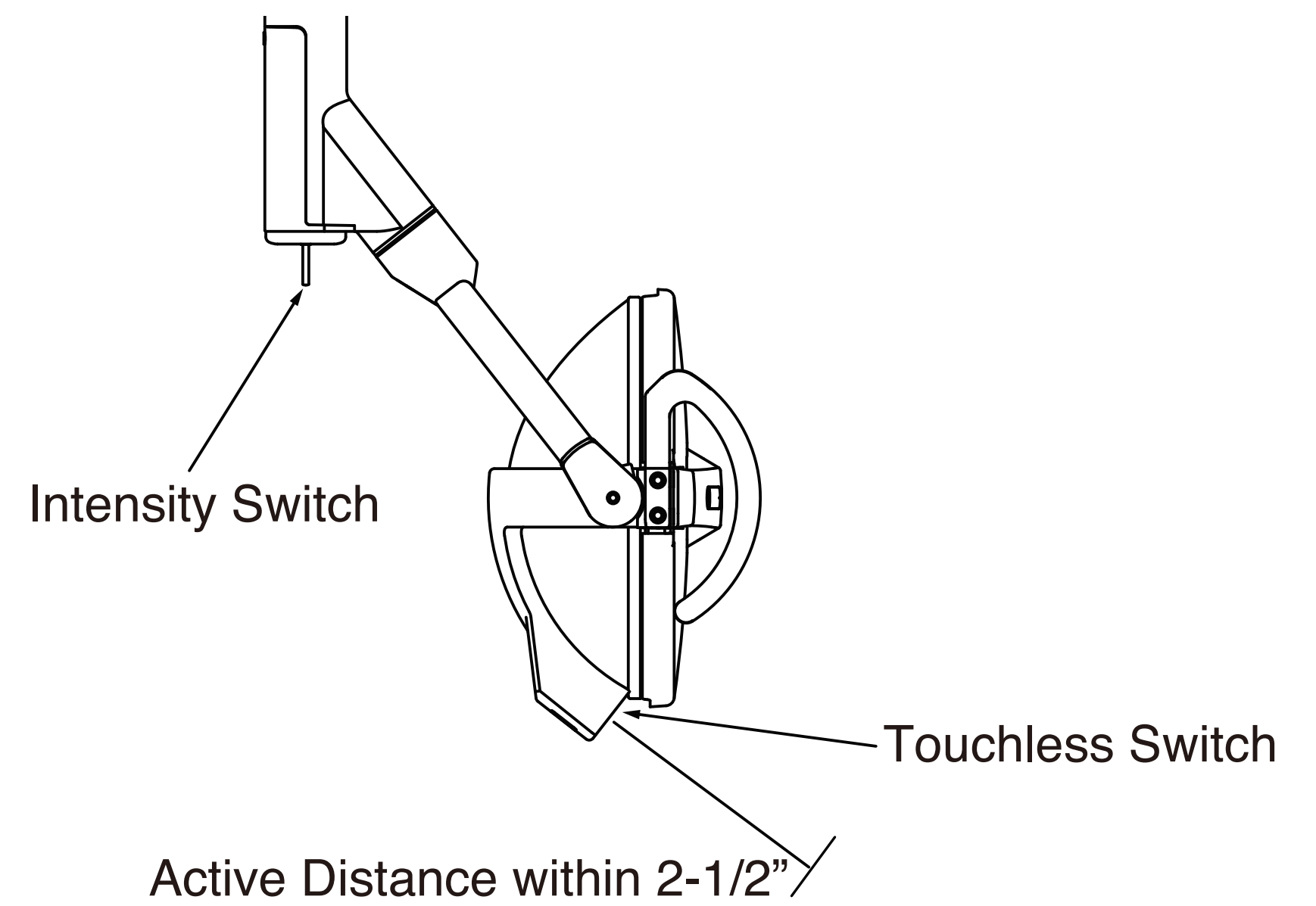

7-2-3. Selection of intensity (High / Low) for normal treatment mode

The intensity will be High by turning the intensity switch to the left. Switch it to Low by turning it to the right.

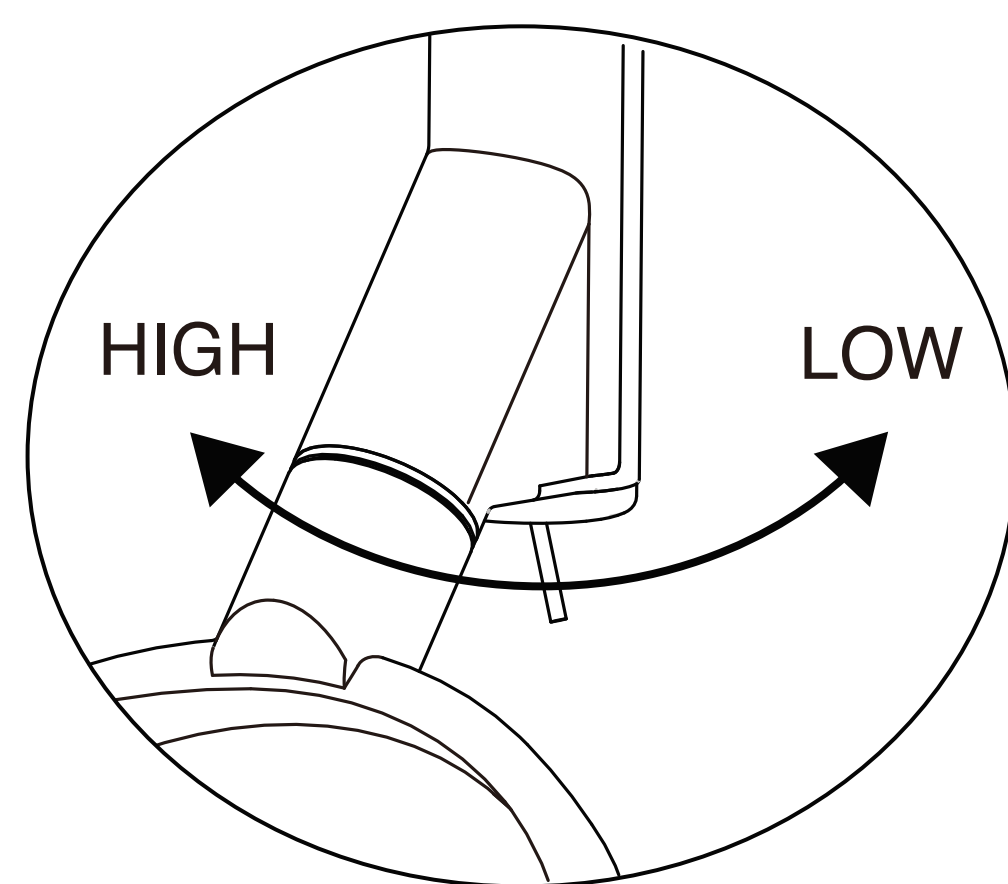

	INTENSITY	
HIGH	28,000 Lux	2600 FTC
LOW	22,000 Lux	2000 FTC

7-2-4. Switching to the composite mode

During normal treatment mode, while the light is on, place and hold your hand within 2-1/2" from the sensor for 2 seconds. The light intensity will be automatically reduced to the composite mode which has intensity of 740 FTC (8000 lux). To switch back to the normal treatment mode, place your hand by the sensor for 2 seconds again.

Note : By placing your hand for 2 seconds when the light is off,

the light does not lit in the composite mode, but lit in normal treatment mode. Please make sure that the light is on before lighting in composite mode.

	INTENSITY	
COMPOSITE MODE	8,000 Lux	740 FTC

[8] ADJUSTMENT OF THE BALANCE ARM

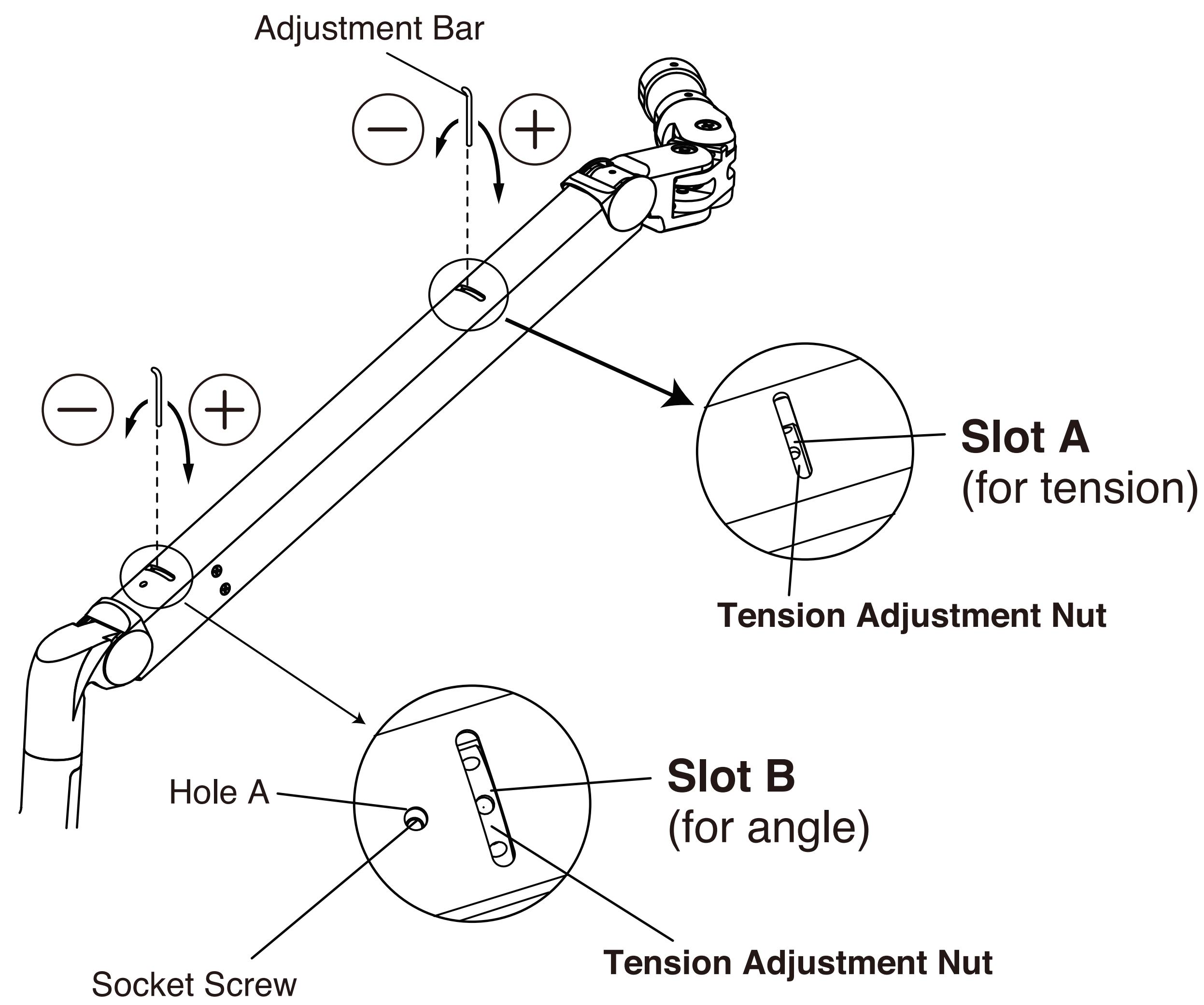

8-1. Adjustment of the tension of the balance arm

Position the angle of the balance arm so the tension adjustment nut becomes visible just under slot A.
Turn the nut and adjust the tension with the adjustment bar supplied with the light.

Direction of rotation of the nut _____
 When the light head tends to go up, turn the nut to + direction.
 When the light head tends to go down, turn the nut to - direction.

8-2 Adjustment of the angle of the light head

- (1) Use a 2mm hex key wrench to loosen socket screw in front of Slot B.
- (2) Position the angle of the balance arm so the head angle adjustment nut becomes visible just under the slot B.
Turn the nut and adjust the tension with the adjustment bar supplied with the light.

Note : Adjusting the head without loosening the socket screw will damage the arm.

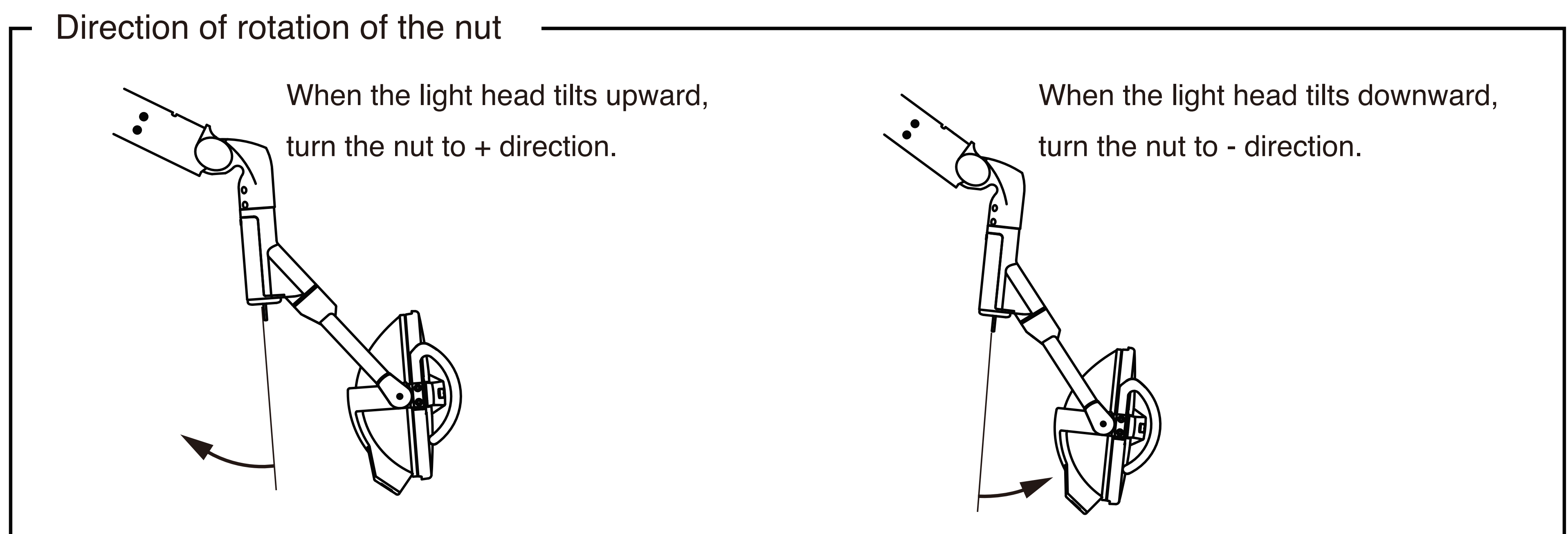

- (3) After adjustment is done, re-tighten the socket.

Note : Unless this socket screw is re-tightened, the angle of the head will be changed during use.

[9] REPLACEMENT OF THE BULB

⚠ CAUTION

Make sure the power supply is turned off.

Halogen bulb and surrounding parts be hot immediately after the lamp goes off. Wait until they get cool down.

IMPORTANT

Do not touch glass with bare hand. Halogen bulb surface must be clean. Oil or body moisture will affect bulb span of life. If glass surface is touched, clean with alcohol.

9-1. Removal of the reflector cover

(1) Turn the light bulb cover fixing screw counterclockwise by 90 degrees with a coin.

(From ■ mark to ● mark. See Fig.1)

(2) Remove the reflector cover by pulling it toward you. See Fig.2

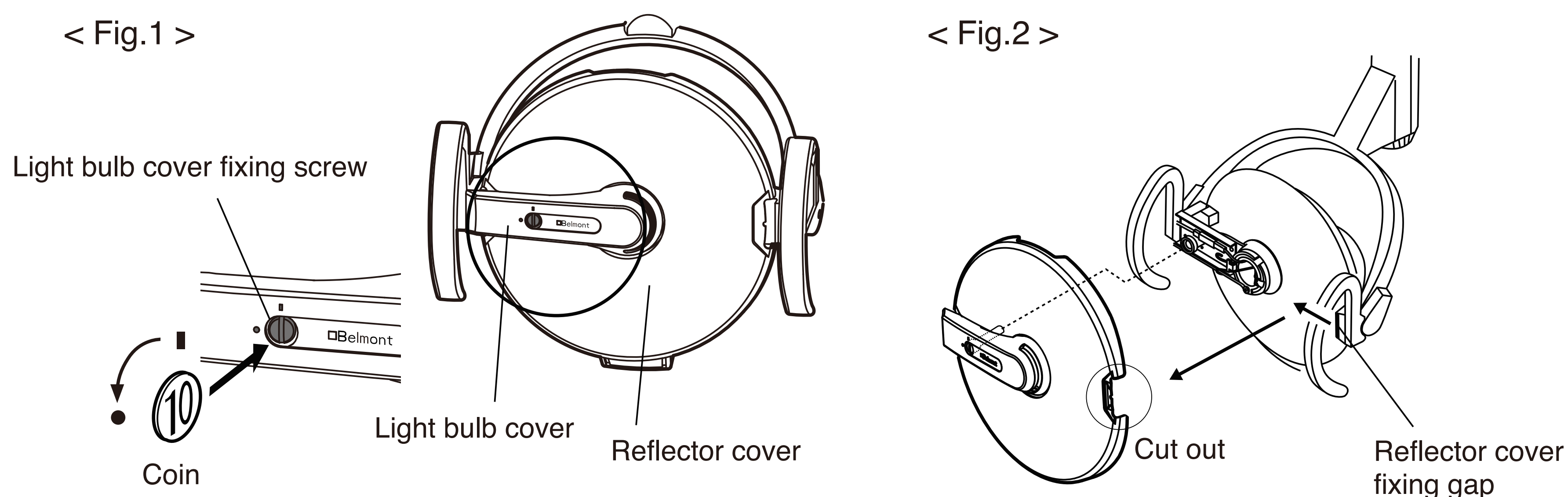

9-2. Replacement of the bulb

(1) Disconnect the connectors. See Fig.3

(2) Push the plastic-coated parts of the bulb retaining spring, and remove it from the hook. See Fig.4

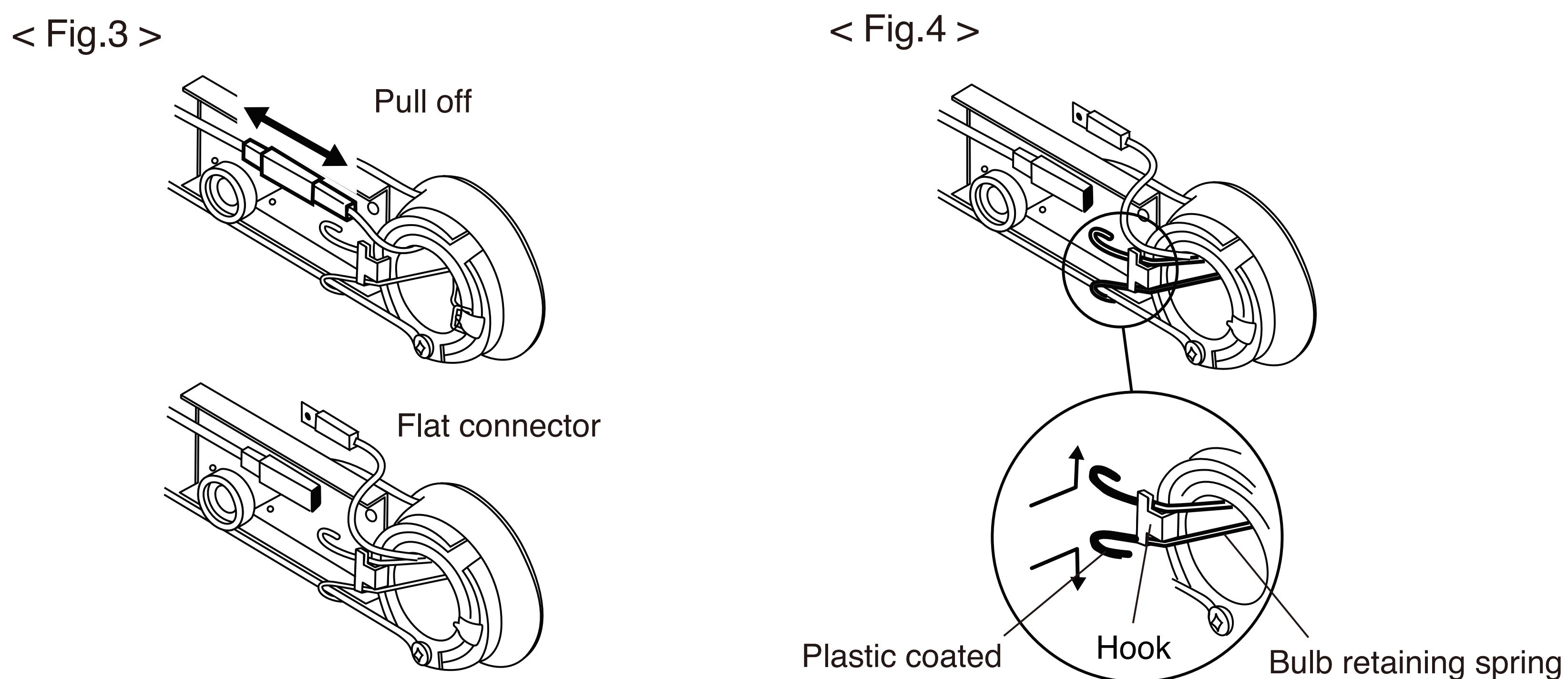

(3) Remove the bulb. See Fig.5

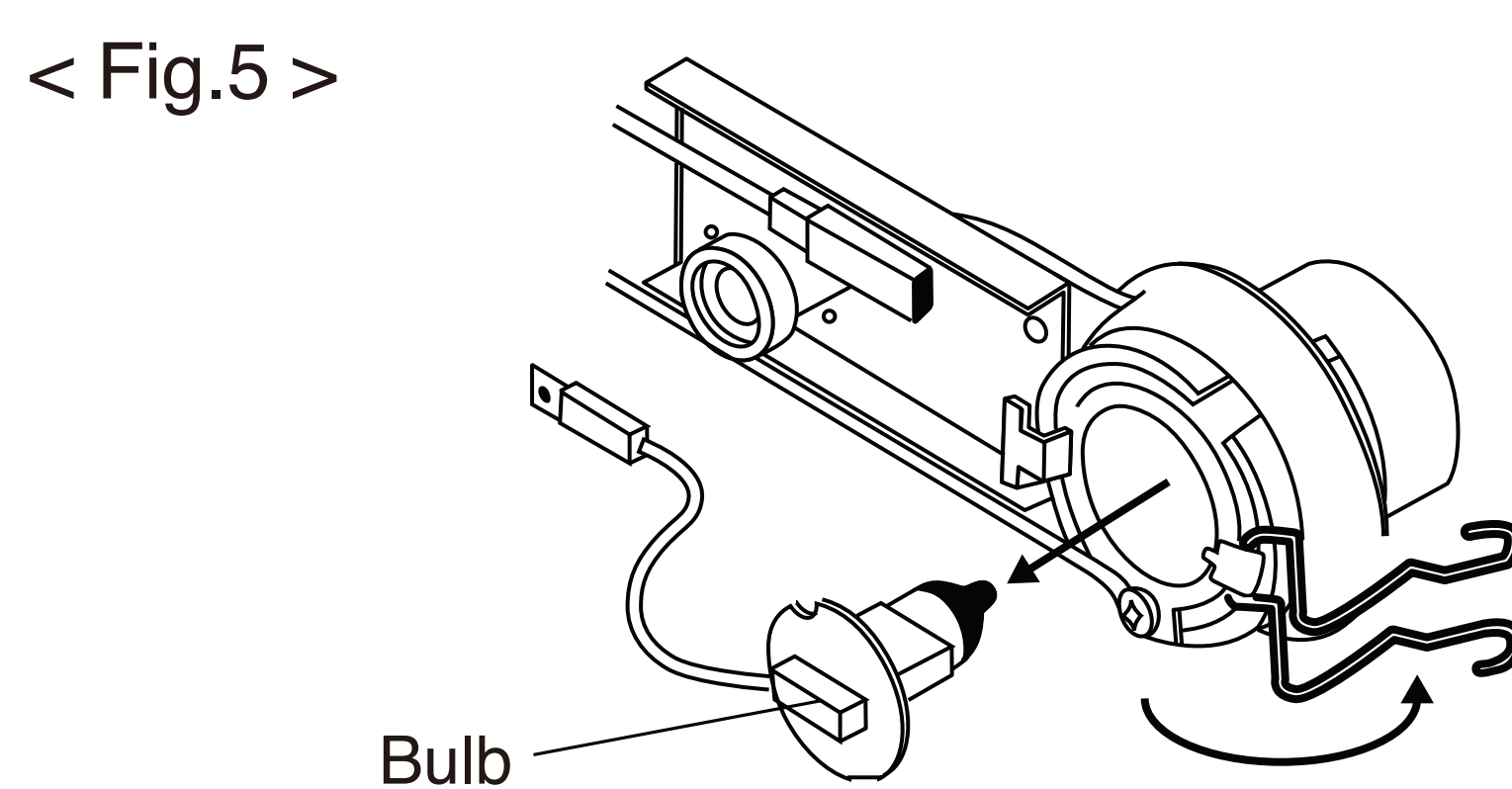

9-3. Inserting a new bulb

IMPORTANT

Replace halogen lamp only with type JA--24V 60W obtainable through your local dealer.

- (1) At inserting the bulb, make sure that the projection of the bulb holder and the cut-out of the bulb are aligned. Misalignment will cause an improper light pattern.

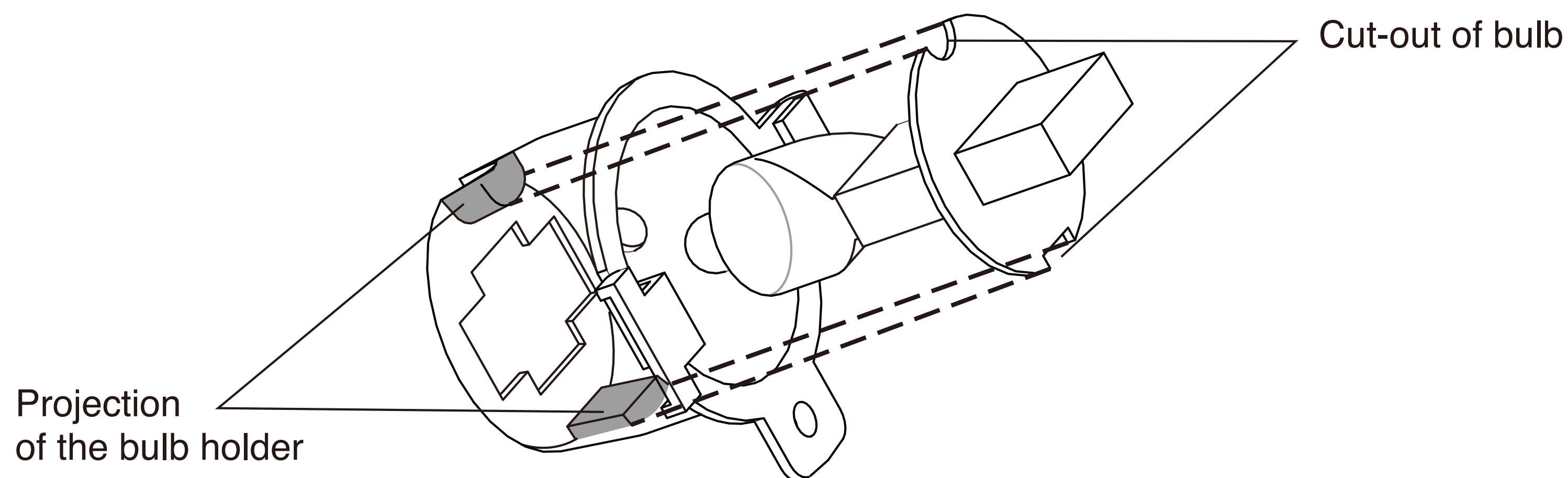

- (2) Close the bulb retaining spring. Make sure to place the springs behind the hook. See Fig.6
- (3) Firmly attach wire connectors. See Fig.7

< Fig.6 >

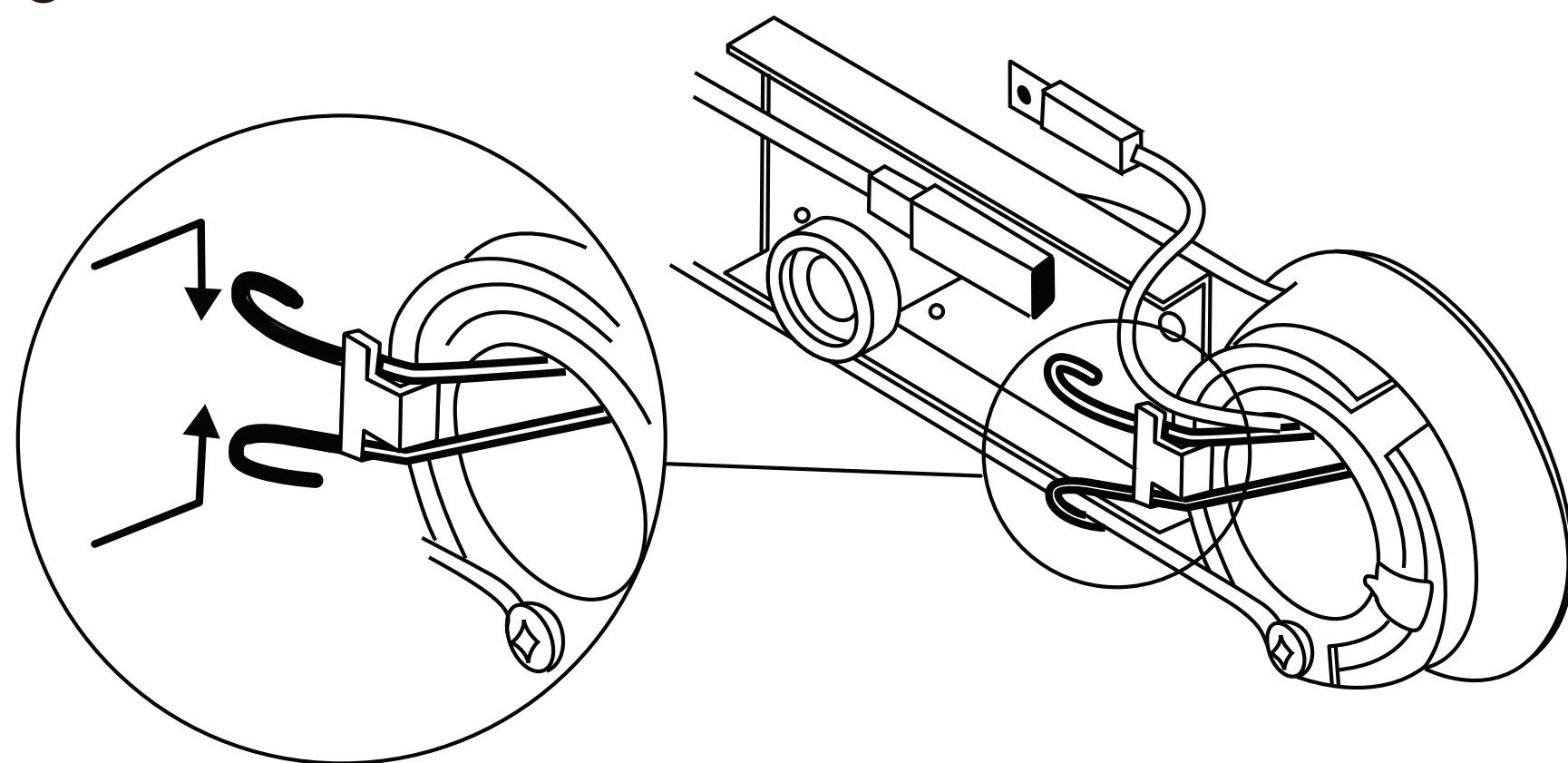

< Fig.7 >

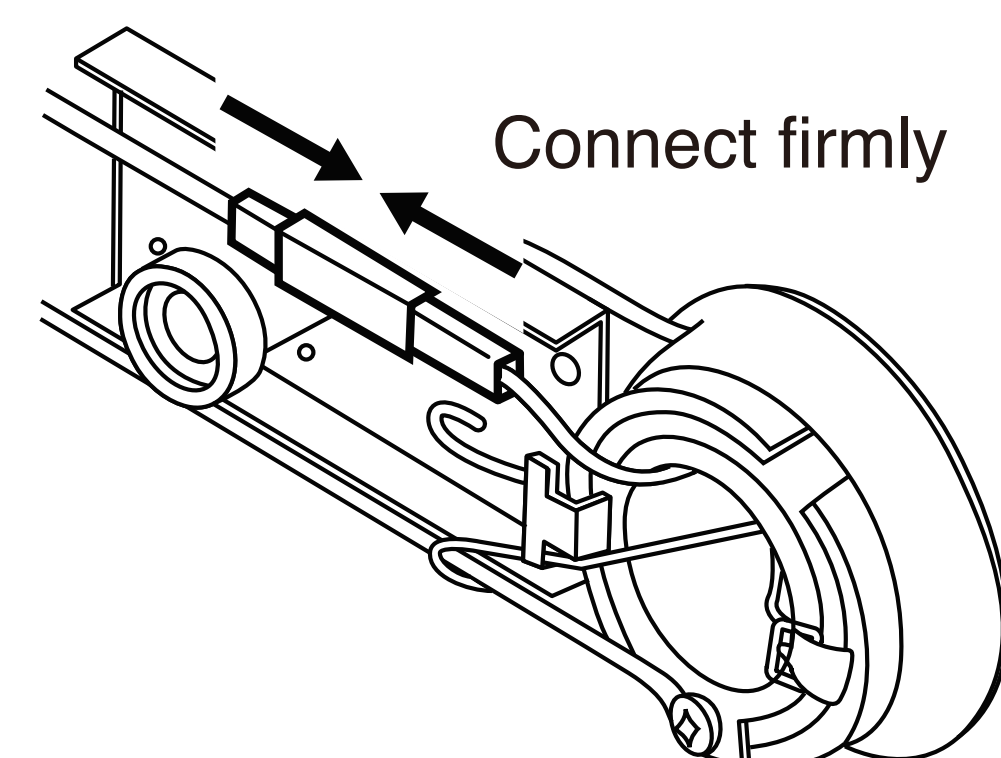

9-4. Attaching the reflector cover

- (1) Insert the cut-out of the reflector cover into the gap at the handle (right). See Fig.8
- (2) Be careful not to pinch the wires when attaching cover. See Fig.9
- (3) Hold the reflector cover and tighten the screw by turning it clockwise by 90 degrees.
(From ● mark to ■ mark.)

Make sure to tighten it by pushing it forward until it clicks. See Fig.10

< Fig.8 >

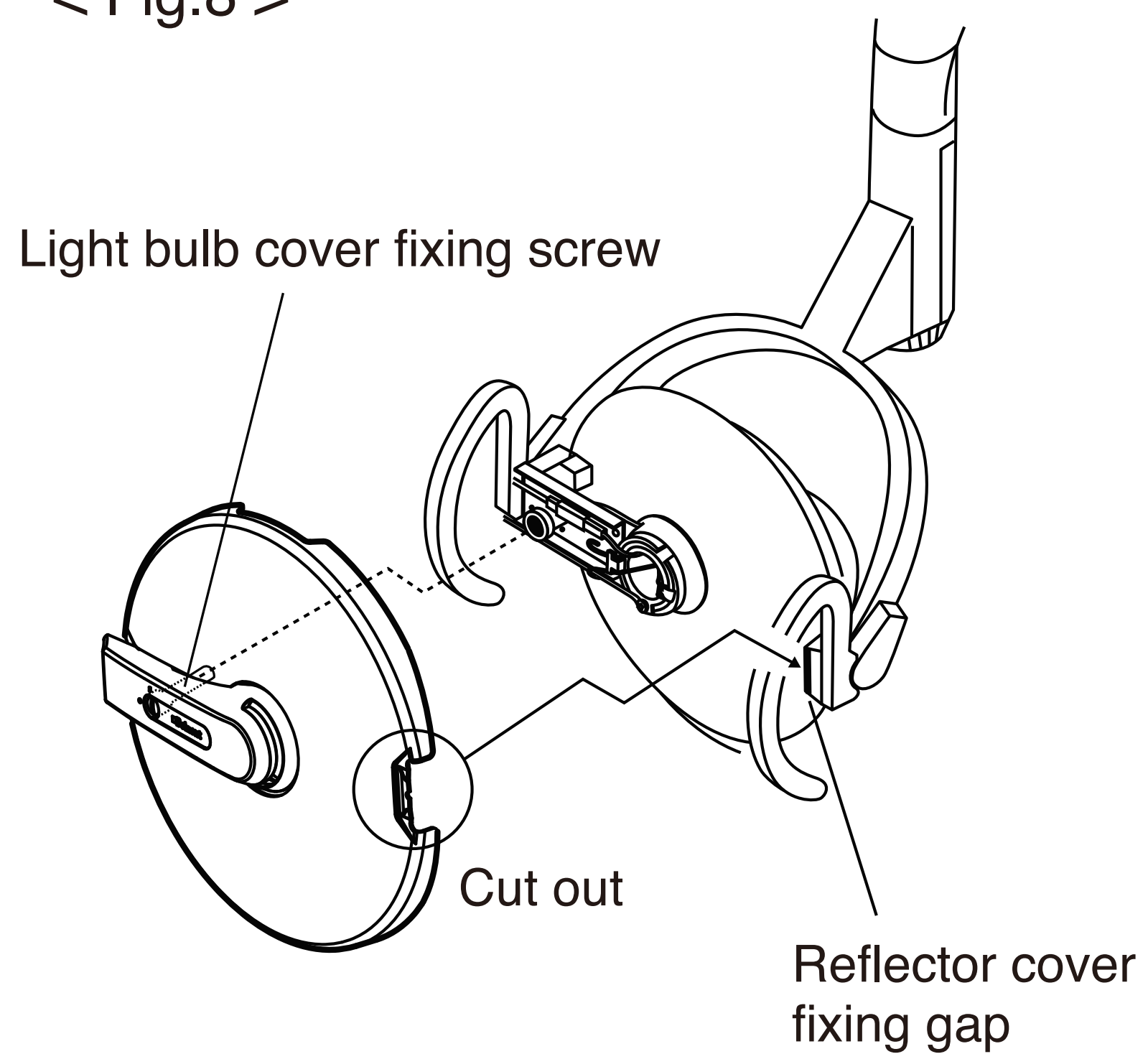

< Fig.9 >

Be careful not to pinch the wires

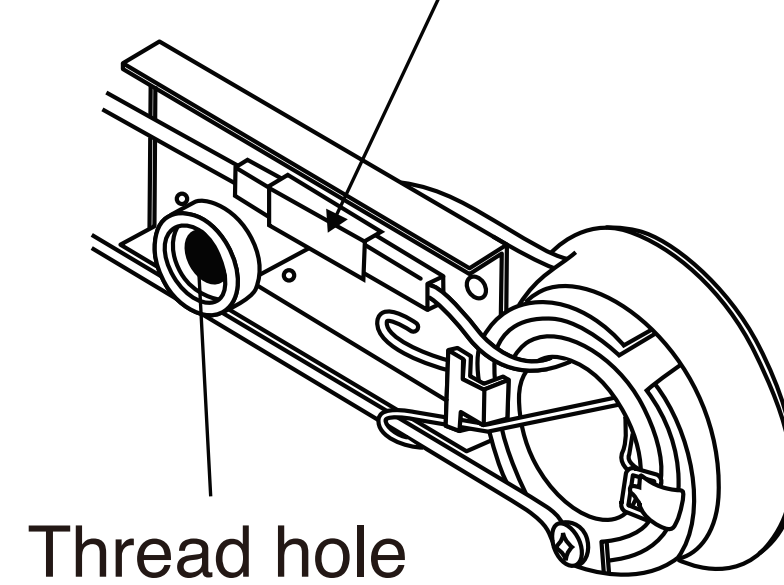

< Fig.10 >

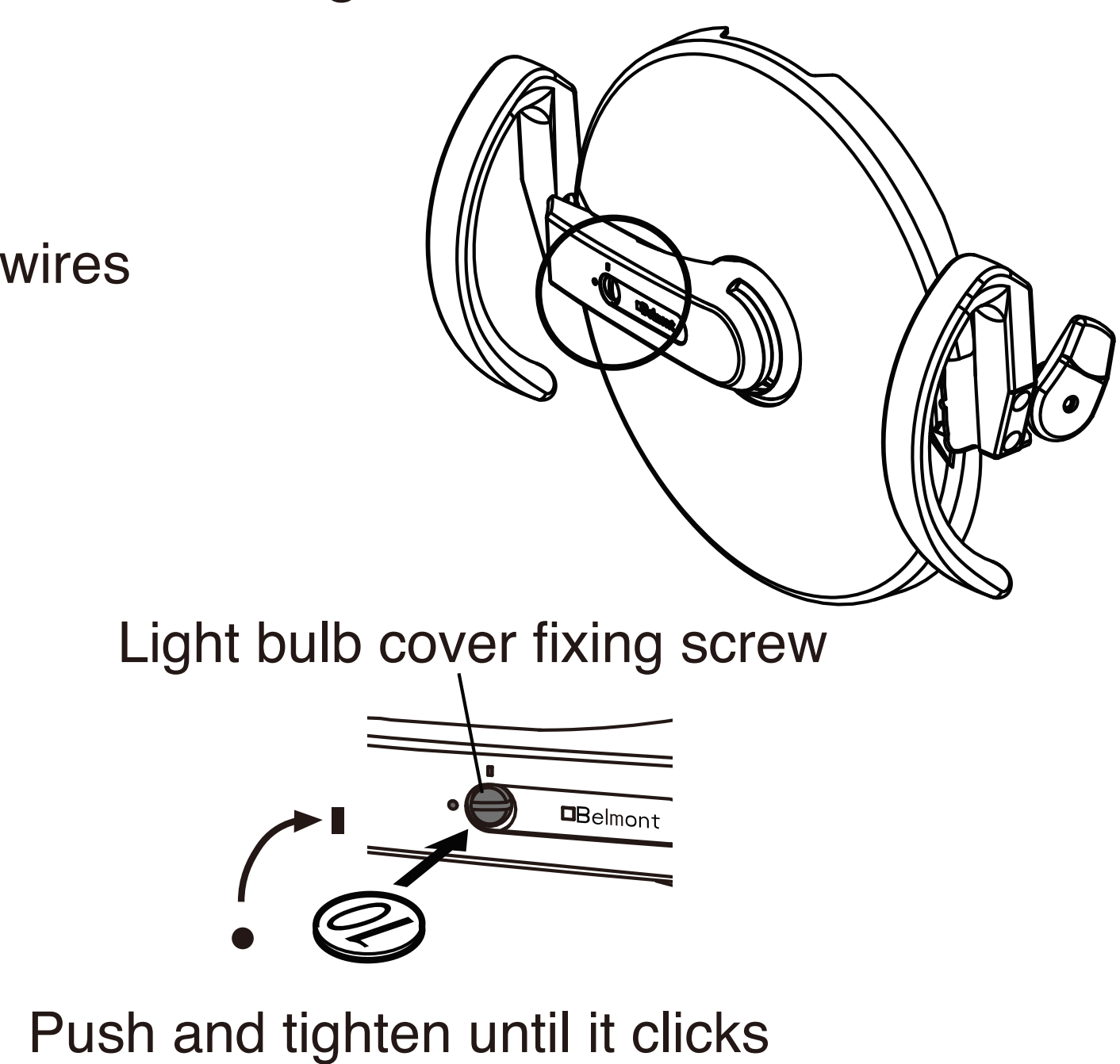

[10] CLEANING

⚠ CAUTION

Allow light to cool prior to cleaning.

Use a soft cloth or cotton only to gently clean surfaces. Use of other materials can scratch and damage surfaces. Covers can be cleaned with a soft cloth or cotton moistened with alcohol. The reflector can be cleaned with a soft and dry cloth or cotton with extreme care.

NOTE



BELMONT EQUIPMENT, Division of Takara Belmont USA, Inc.

101 Belmont Drive Somerset, New Jersey 08873 U.S.A. TEL.:(732) 469-5000 / (800) 223-1192 Fax.:(732)526-6322 / (800) 280-7504

TAKARA CO, CANADA LTD.

2076 S. Sheridan Way, Mississauga, Ont., L5J2M4, Can. TEL.:(905) 822-2755 Fax.:(905)822-6203