

VACUUM VALVE SERVICE & MAINTENANCE

PRIOR TO STERILIZATION

Minimize the potential accumulation of debris that could interfere with the operation of the instrument by flushing clean water through it while working the valve lever open and closed several times.

1. Using mild cleaner and water, wipe all surfaces of the valve and dry with a clean, soft cloth.
2. Use a stiff HVE or SE cleaning brush of an appropriate size to dislodge internal buildup.

NOTE

Do not ultrasonically clean, as instrument surface finishes may be damaged.

PERIODIC MAINTENANCE

If the operation of the valve becomes sticky or stiff it may be necessary to remove the valve spool for a thorough cleaning and lubrication. Refer to the appropriate exploded view shown in Figure 4.

1. Gently lift one end of the plastic on/off lever (V-1103/V-1203) out from the indentation on the end of the spool.
2. Push the spool out of the valve toward that side and completely disengage the lever from the other end.
3. Clean the spool and inspect O-rings and replace those that have nicks, cuts, flat spots or show signs of wear. Lubricate O-rings with O-ring lube then reassemble the valve.

SURFACE DISINFECTION

Bleach or Sodium Hypochlorite solutions may permanently damage the valve. Some surface disinfectants that will not harm the valve are Birex SE, Sporidicin, Coldspor, Procide Spray, Sterall Spray, Asepti-IDC, Biocide, Promedyn, Iodo-Five, Wescodyne, and Cavicide.

METHODS OF STERILIZATION

You may sterilize Belmont Autoclavable Valves by any of the following methods: Chemical Vapor Method, Ethylene Oxide, Steam Autoclave or Dry Heat.

NOTE

Temperature should never exceed 280 degrees Fahrenheit, or 138 degrees Celsius. Do not place the instrument in close proximity to the sterilizer heating element. Avoid contact with the sterilizer walls.

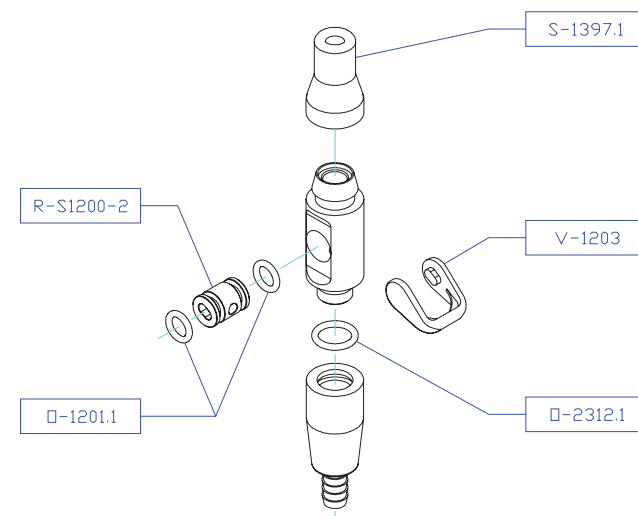
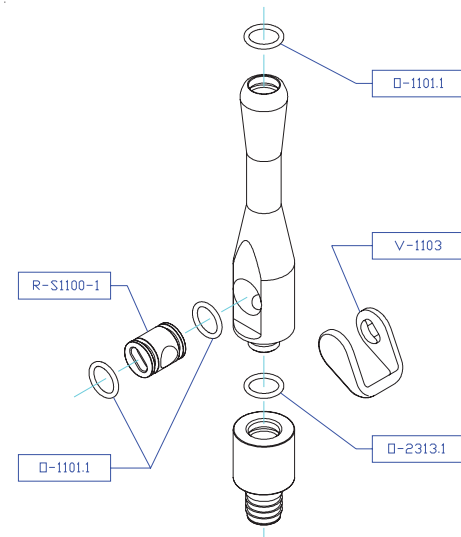
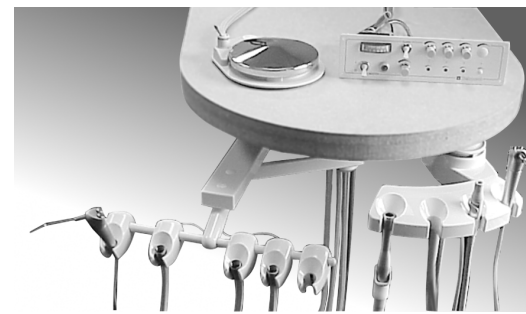

Figure 4. Vacuum Valves.

Belmont

A DIVISION OF TAKARA BELMONT USA, INC.
101 Belmont Drive Somerset, NJ 08873
Phone: (800) 223-1192 Fax: (732) 356-1035



OPERATOR'S GUIDE

BDS-2561 LEFT/RIGHT DUO DELIVERY SYSTEM

The Belmont BDS-2561 Left/Right cabinet mounted Duo Delivery System features an automatic panel mount control for three handpieces, expandable to four with doctor's 3-way air/water syringe, master on/off with indicator, individual handpiece adjustment, non-retraction water coolant with on/off, individual water coolant adjustment, 4-hole Midwest oblate handpiece tubing, and a wet/dry type foot control.

OPERATING/CONTROL INSTRUCTIONS

All controls are located on the front panel. Figure 1 shows the location and identifies the function of these controls.

MASTER ON/OFF

Turns on air and water for the complete system. *Flip toggle forward to activate system.* Always turn the toggle OFF when not in use.

MASTER ON/OFF INDICATOR

Provides visual proof that the system is pressurized when the MASTER ON/OFF is in the ON position.

DRIVE AIR PRESSURE CONTROL

Allows handpiece to be adjusted to its manufacturer's recommended operating pressure. *Turn the adjusting screw counter clockwise to increase the pressure, clockwise to decrease the pressure.*

DRIVE AIR PRESSURE GAUGE

Indicates drive air pressure to the handpiece.

HANDPIECE FLUSH CONTROL

Activates handpiece high volume water flow through handpiece water coolant lines. *Flip the toggle up to activate the system.*

WATER COOLANT FLOW CONTROL

Allows adjustment to be made to the handpieces. *Turn the knob counter clockwise to increase the flow, clockwise to decrease the flow.*

Figure 2 shows automatic handpiece holder & syringe holder assembly.

AUTOMATIC HANDPIECE HOLDER

Signals the automatic control system to supply drive air and air/water coolants to handpiece as it is lifted from its holder. When the handpiece is placed back into its holder, a signal to the automatic control system stops the drive air and air/water coolant supply.

FOOT CONTROL

Is used to regulate the drive air to the active handpiece. To operate, apply pressure to the foot control cover.

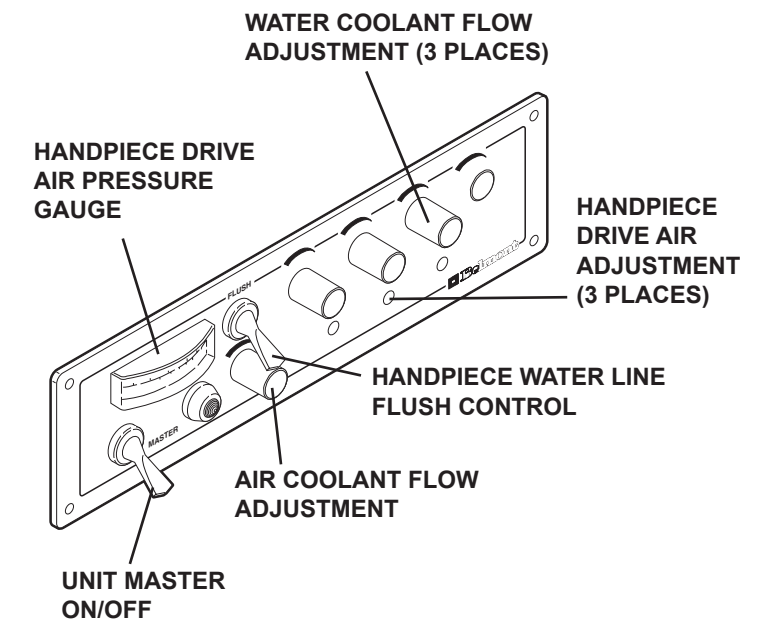

Figure 1. Handpiece control functions.

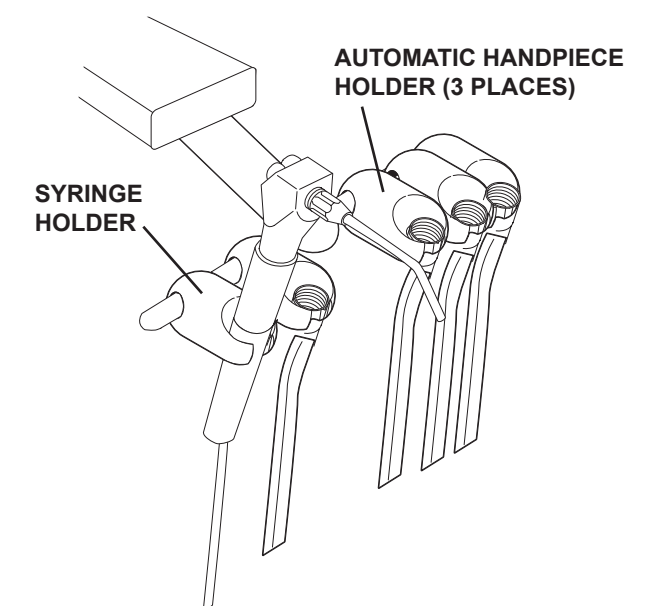

Figure 2. Automatic handpiece holder assembly.

Belmont

A DIVISION OF TAKARA BELMONT USA, INC.
101 Belmont Drive Somerset, NJ 08873
Phone: (800) 223-1192 Fax: (732) 356-1035

FINAL ADJUSTMENTS

Adjust air and water regulated pressure.
Adjust handpiece pressure.
Check for any leaks.

CLEANING

BARRIER TECHNIQUE

The first choice in the protection of dental equipment should be the use of disposable barrier products. The repeated use of disinfectants on equipment surfaces without the constant removal of the solution residue will eventually cause some damage to equipment surfaces.

CHEMICAL DISINFECTION

The manufacturer of the disinfectant to be used should be contacted for them to state that the disinfectant will not damage equipment surfaces including upholstery.

UNACCEPTABLE DISINFECTANTS

The following chemicals may damage equipment and upholstery:

- * Alcohol based solutions
- * Bleach
- * Phenol/Alcohol combinations
- * Foam spray products

USE WITH CAUTION

* Water based phenolic disinfectants following exactly the instructions for use.

BELMONT WARRANTY DOES NOT COVER DAMAGE TO EQUIPMENT AND UPOHOLSTERY CAUSED BY DISINFECTANT SOLUTIONS.

WARRANTY

Belmont Equipment is warranted by the manufacturer to be free from defective material and workmanship under normal use and service, for a period of two (2) years from date of shipment to the Buyer, except that any part or parts that are replaced under this Warranty within ninety (90) days of the completion of the two year period shall be warranted to be free from defective material and workmanship for a period of ninety (90) days from date of shipment of said parts to Buyer. Belmont will repair or replace any defective part under this Warranty, provided the part is returned to our factory with prepaid postage, delivery or freight charges. In the event Warranty service must be performed to correct any defect, only Belmont and/or one of its authorized dealers shall provide same upon mutually agreeable arrangements made in advance.

Except as otherwise provided herein, there is NO WARRANTY, representation or condition of ANY KIND, express or implied (including NO WARRANTY OF MERCHANTABILITY OR FITNESS) and none shall be implied by law. THE EXPRESS WARRANTY AND THE REMEDIES CONTAINED HEREIN (1) ARE MADE SOLELY TO THE FIRST PURCHASER FOR BENEFICIAL USE (THE BUYER), (2) ARE THE SOLE WARRANTIES AND REMEDIES, (3) ARE IN LIEU OF ALL OTHER WARRANTIES, GUARANTEES, AGREEMENTS OR OTHER LIABILITIES, WHETHER EXPRESS OR IMPLIED, AND ALL OTHER REMEDIES FOR BREACH OF WARRANTY OR ANY OTHER LIABILITY OF BELMONT. IN NO EVENT SHALL BELMONT BE LIABLE FOR CONSEQUENTIAL OR INCIDENTAL DAMAGES.

No person, agent, distributor or dealer is authorized to change, modify or extend the terms of the Warranty in any manner, whatsoever.

This warranty is void when failure or defect is caused by conditons beyond the manufacturer's control, such as damage resulting from mis-handling, neglect, misuse, improper maintenance, accident or alteration or repair by anyone other than Belmont or an authorized Belmont dealer.

Labor required to repair, replace or retrofit is not included during the warranty period by the manufacturer.

SYRINGE SERVICE & MAINTENANCE

TIP STERILIZATION

1. To remove syringe tip, push in collar ring, then firmly grasp tip and pull away from syringe head.
2. After sterilization, replace the tip by pushing in collar ring on syringe, then by inserting tip until it is firmly seated.

Release collar ring to lock tip securely to syringe.

NOTE

Be sure to rinse all cleaning agents from the tip prior to sterilization. You may sterilize syringe tips by any of the following methods; Chemical Vapor, Ethylene Oxide or Steam Autoclave. Temperatures should never exceed 280 degrees Fahrenheit, (138 degrees Celsius).

INSTALLATION

1. Turn off AIR and WATER supplies.
 2. Unscrew syringe handle and determine which fitting leads to the air button.
 3. Slide syringe handle down over the syringe tubing. Select the air side of the syringe tubing and connect to the air fitting on the syringe.
 4. Repeat with the water tubing to the water fitting. Ensure that the unit end of the syringe tubing is properly connected to the air and water supply fittings on the dental unit.
- Recommended operating pressures:
AIR 80 psi, WATER 40 psi.

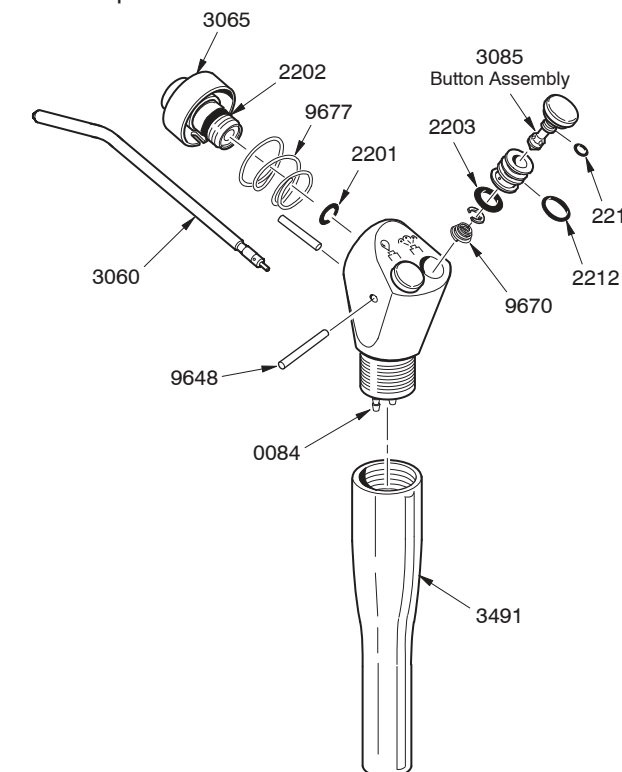

Figure 3. Syringe.

TROUBLE SHOOTING

Problem: Water leakage around the buttons
Solution: Replace the button assembly #3085. To remove the button, hold buttons down, remove the retaining pin & gently lift under the button. When re-installing the button, be sure the spring is properly seated, with the smaller end facing upward. While holding both buttons down, insert the retaining pin through the syringe head.

Alternatively, you may replace the O-rings on the button assembly, using Syringe Repair Kit #3066. After removing the button, slide the E-ring from the stem, and pull the button from the spool.

Problem: Water spray when air button is pressed
Solution: Check first to ensure that the syringe tip is undamaged and fully seated in the tip adapter assembly. If it is the O-ring (#2201) under the tip adapter assembly it should be replaced. Remove the tip, and use a 5/32 inch hex key to unscrew the assembly from the syringe head. Use a dental pick or a bent paper clip to remove the small O-ring from the bottom of the bore in the syringe body. Be careful not to nick or scratch the sealing surfaces. The best way to install the replacement O-ring is to slip it onto the end of a syringe tip, apply silicone lubricant, then insert it into the bore.

Before reinstalling the tip adapter assembly, look down into the bore in the syringe body and assure that the alignment pin is in place. With the spring in place in the collar, align the slot in the collar with the pin, then push the collar into the syringe body. Tighten the assembly firmly, holding the hex key by the short end, with the long end inserted into the tip adapter assembly. By holding the hex key this way, you will have approximately the right torque.



A DIVISION OF TAKARA BELMONT USA, INC.
101 Belmont Drive Somerset, NJ 08873
Phone: (800) 223-1192 Fax: (732) 356-1035



A DIVISION OF TAKARA BELMONT USA, INC.
101 Belmont Drive Somerset, NJ 08873
Phone: (800) 223-1192 Fax: (732) 356-1035