

Belmont Dental Delivery Systems

Operation and Maintenance Instructions

Series 2500

X-Calibur Units



Table of Contents

| | Page |
|---|-------------|
| Customer Unit Identification Record | 1 |
| General Unit Anatomy | 2 |
| Types Of Units | 3 |
| Description of Components | 5 |
| Control Head Features | 5 |
| Cuspidor Features | 7 |
| Post Mounted Utility (PMU) Features | 7 |
| Assistant Instrument Holder Arm | 8 |
| Handpiece Adjustments | 9 |
| Syringe Adjustments | 11 |
| Care and Maintenance of the X-Calibur Dental Unit | 12 |
| 1) Establish a maintenance record | 12 |
| 2) External Surfaces | 13 |
| 3) Water System Care and Maintenance | 13 |
| 4) Syringes | 14 |
| 5) HVE and SE | 15 |
| 6) Cuspidor Drain Line | 16 |
| 7) Cuspidor Bowl, Bowl Rinse and Cup Fill Spouts | 16 |
| 8) Solids Collector | 16 |
| 9) Bowl Rinse Time Adjustment | 16 |
| 10) Balance Arm Adjustment | 17 |
| Warranty | Back Cover |

X-Calibur Chair Mounted Delivery Systems

Chair-Mounted, Over the Patient Units

| Model | Description | |
|-----------------|--|--|
| BDS-2500 | Doctors 3 HP Control w/ syringe, Post Mounted Utility (PMU) with Gravity Drain Cuspidor, Telescoping arm & Assistant Instruments. | |
| BDS-2510 | Doctors 3 HP Control w/ syringe, Post Mounted Utility (PMU), Telescoping arm & Assistant Instruments. (No Gravity Drain Cuspidor) | |
| BDS-2505 | Doctors 3 HP Control w/ syringe, Post Mounted Utility (PMU) with Gravity Drain Cuspidor. (No Telescoping Arm w/ Asst. Instr.) | |
| BDS-2515 | Doctors 3 HP Control w/ syringe, Post Mounted Utility (PMU) . (No Gravity Drain Cuspidor w/ Telescoping Arm & Asst. Instr.) | |

Cuspidors/Post Mounted Utility (PMU)

| Model | Description | |
|-----------------|--|--|
| BDS-2520 | Post Mounted Utility (PMU) w/ Gravity Drain Cuspidor, Telescoping arm & Assistant Instruments. | |

Swing-Mounted Units

| Model | Description | |
|-----------------|--|--|
| BDS-2570 | Swing Mounted Doctors 3 HP Control w/ syringe. Swing Mounted <i>CLESTA</i> Light. | |
| BDS-2575 | Swing Mounted Doctors 3 HP Control w/ syringe. | |

Serial Numbers (units):

Serial Numbers (lights):

Chair Make, Model and Serial Number:

GENERAL UNIT ANATOMY

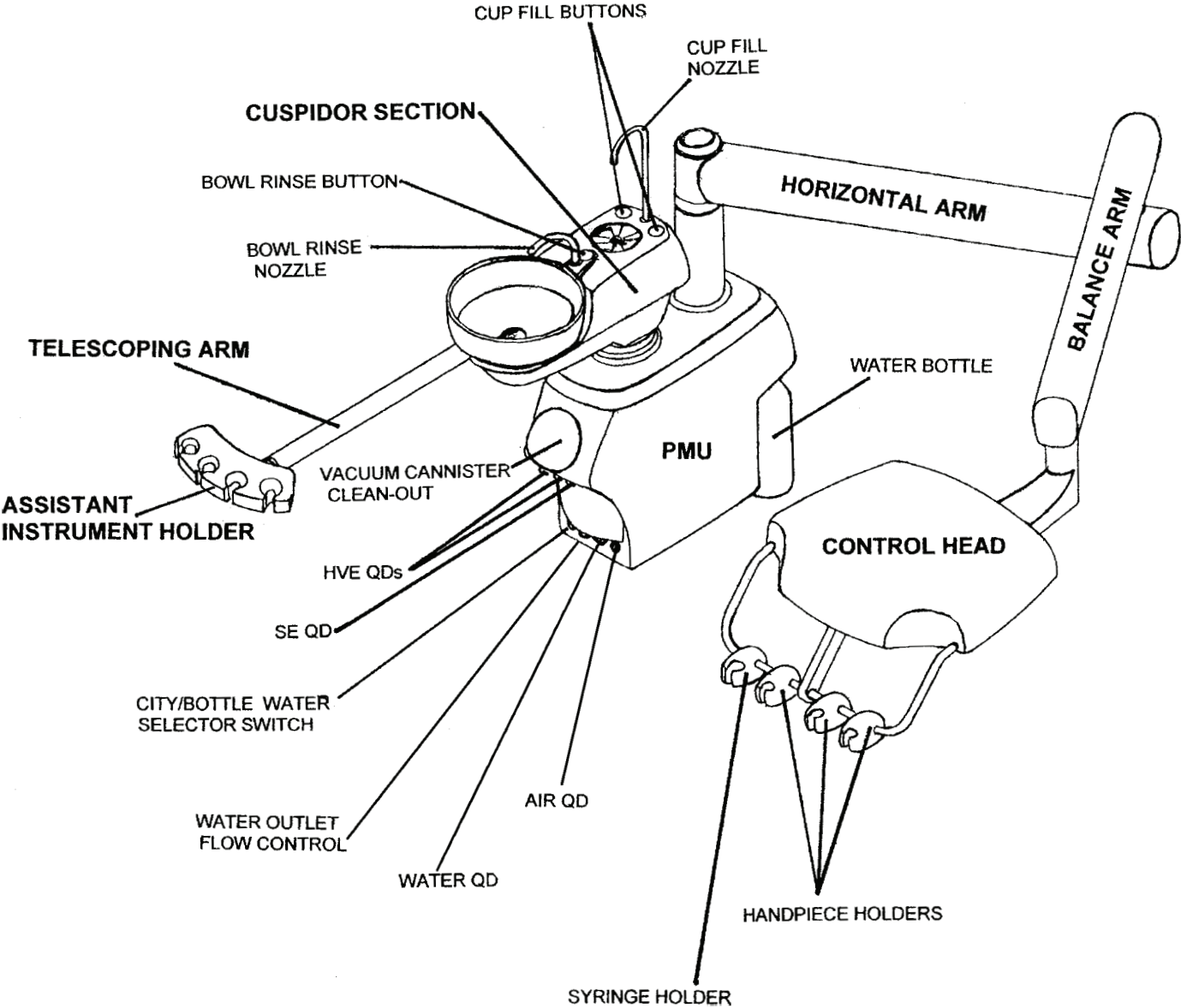

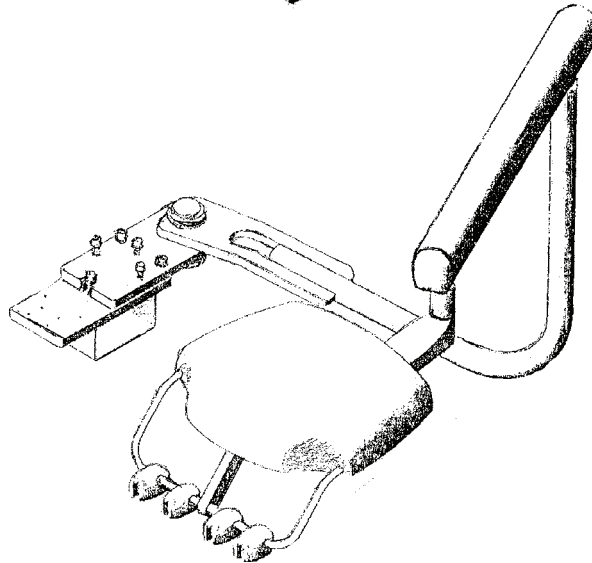
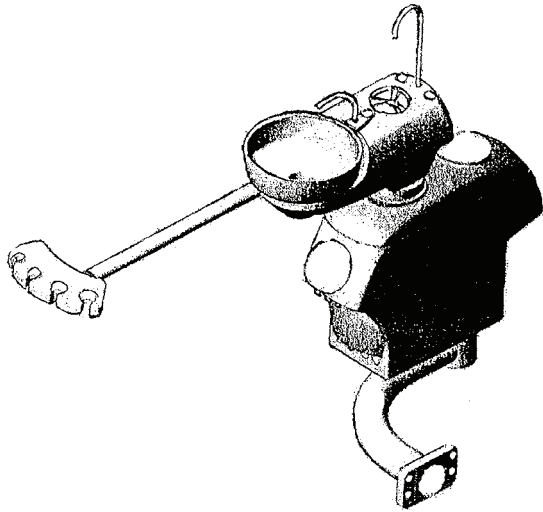
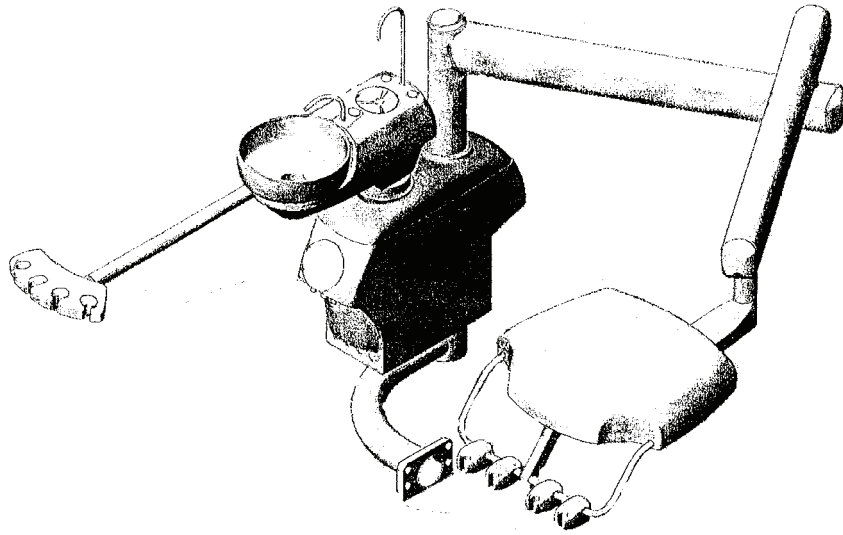

Chair Mounted, Over The Patient Units

Description: Delivery System is composed of Control Head, Balance Arm, Horizontal arm, Post Mounted Utility (PMU). Models are offered both with and without a Gravity Drain Cuspidor and Telescoping Arm with Assistant Instruments.

The Delivery System is attached to the chair by a fixed bracket and moves up and down in unison with the chair.

The control head is mounted on a movable arm system that allows a full range of vertical and horizontal movement. An air operated brake system locks the arm against vertical movement once it is positioned.

Cuspidors/Post Mounted Utilities

Description: Equipment consists of a chair mounted Post Mounted Utility (PMU) center either with or without a Gravity Drain Cuspidor and Telescoping Arm with Assistant Instruments.

The equipment is attached to the chair by a fixed bracket and moves up and down in unison with the chair.

Swing Mounted Units

Description: The Delivery System includes a Control Head, Balance Arm and Swing arm. Some models include a *Clesta* Dental Light or a *Bel-Halo* LED Dental Light on a Swing Arm.

The swing arm allows the Control Head and Light to be positioned on either the left or right side of the chair. This equipment provides the flexibility for both left and right handed dentists to share the same equipment in one operatory.

The control head is mounted on a movable arm system that allows a full range of vertical and horizontal movement. An air operated brake system locks the arm against vertical movement once it is positioned

The Delivery System moves up and down in unison with the chair.

Description of Components

Control Head (Doctor Table)

Master Switch

A toggle switch activates shut-off valves that supply air and water to the unit. This switch is located at the rear right hand corner of the control head.

Note: *****Switch toggle to OFF position when room is not occupied*****.

Air Coolant Control Knob (Yellow)

A single flow control valve varies the flow of air to all handpiece positions simultaneously. This knob is on the right side of the control head.

Balance Arm Brake Switch

This toggle switch serves to lock or release the balance arm position. This switch is located at the front right corner of the control head.

Handpiece Spray Water Control Knobs (Blue)

Individual control valves vary the flow of water to each handpiece. These knobs are located below the front edge of the control head.

Control Head Syringe Air and Water Flow Control Knobs

Individual flow control knobs vary flow of Air (Yellow) and Water (Blue) to the syringe. The knobs are located on the front left corner of the control head.

Handpiece Flush-out Switch

This momentary toggle switch allows water to flush out all handpiece tubing simultaneously. This switch is located on the left side of the control head.

Handpiece Holders with Automatic Valves

Each handpiece holder has a built-in automatic valve. Lifting a handpiece from the holder activates the valve. Replacing the handpiece closes the valve.

(Option) Remote Bowl Rinse Switch - Control Head Mounted

Momentary toggle switch remotely activates the cuspidor bowl rinse valve from the control head. The switch mounting location is along the right edge of the control head.

(Option) Remote Cup Fill Switch - Control Head Mounted

Momentary toggle switch remotely activates the cuspidor cup fill valve from the control head. The switch mounting location is along the right edge of the control head.

Control Head (Side Views)

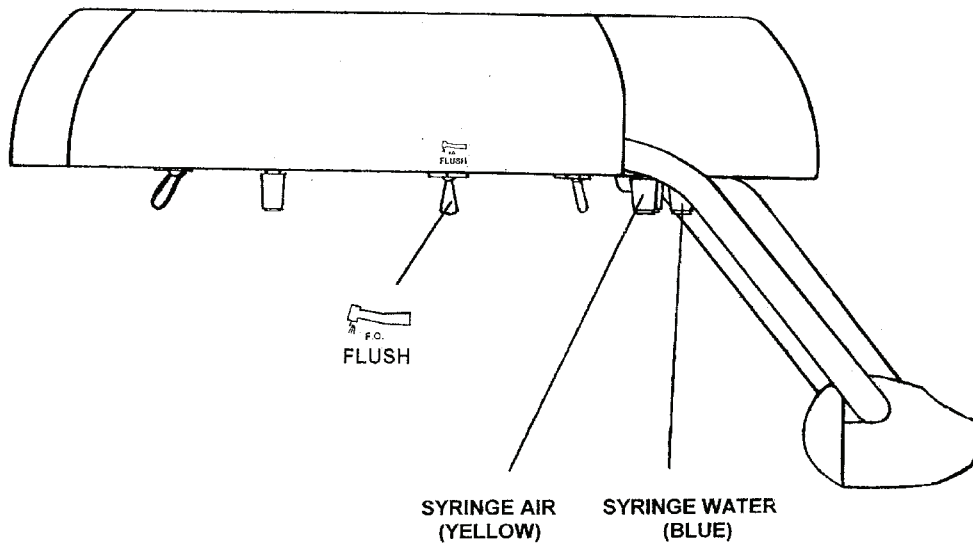
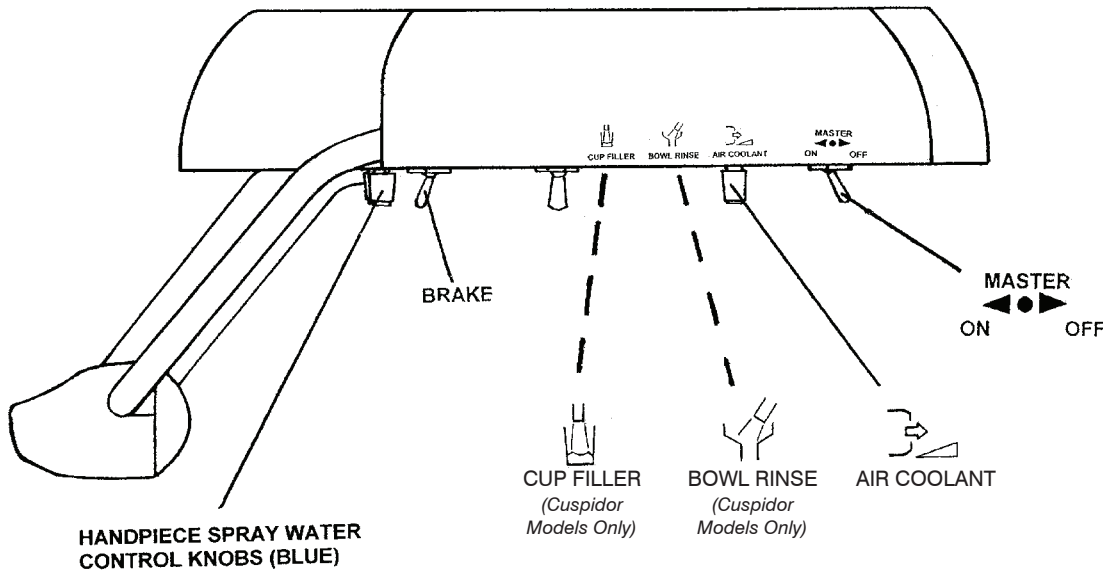

Cuspidor

Cup Fill Button

The cuspidor cup fill valve is activated by either one of two push buttons located directly behind the cup fill spout on top of the cuspidor housing.

Bowl Rinse Button

A single push button switch activates the cuspidor bowl rinse valve. The button is located on top of the cuspidor housing, directly behind the cup fill spout.

***Note: The bowl rinse time can be varied by using a slotted screwdriver to adjust the air flow exhaust valve located inside the PMU.

Glass Bowl

Bowl can be removed for daily cleaning.

PMU

Air Quick Disconnect

¼" Female Q.D. with integral shut-off valve. Yellow hex nut identification.

Water Quick Disconnect with Outlet Flow Control

¼" Female Q.D. with integral shut-off valve. Blue hex nut identification. Water flow can be adjusted by using the outlet flow control needle valve.

Bottled Water System

A 2- position selector switch is located on the front of the post-mounted utility box. This switch will allow the user to select from either a bottled water or municipal water source. Selecting the bottled water position provides the user with an isolated water source for the syringes and the handpieces on the delivery system. Both cup fill and bowl rinse water are supplied by the municipal supply regardless of the position of the selector switch. The city water selector switch position supplies municipal water to the syringe, handpiece, cup fill and bowl rinse functions.

WARNINGS: The bottled water system pressure is pre-set at 40 PSI prior to shipment. Readjustment of the bottled water system pressure can result in personal injury and/or damage to the dental unit. Use only the water bottle that is supplied with the *X-Calibur* unit. Use of other bottles can result in personal injury and/or equipment damage.

Water bottles used on Belmont units are not autoclavable.

To use the water system, fill the bottle to a level just below the neck with sterile water. Hand tighten the bottle into the threaded receptacle in post-mounted utility center. Flip the switch to BOTTLE position. Check for any leakage and tighten as necessary.

When re-filling the bottle, flip the switch to the CITY position, and **slowly** unscrew the bottle to release residual air pressure. Repeat procedure outlined in preceding paragraph.

Assistant Instrument Holder Arm

Units that include assistants instruments (syringe, HVE, SE) are equipped with a 4-position holder and a telescoping arm that slides in and out. The telescoping arm is attached to a yoke, which allows the instruments to be placed in a wide variety of working positions. A built-in breakaway feature prevents potential damage to the arm in the event that it is inadvertently left over the chair when the seat back is raised.

A short, non-telescoping arm is available for users that prefer to keep instruments closer to the patient.

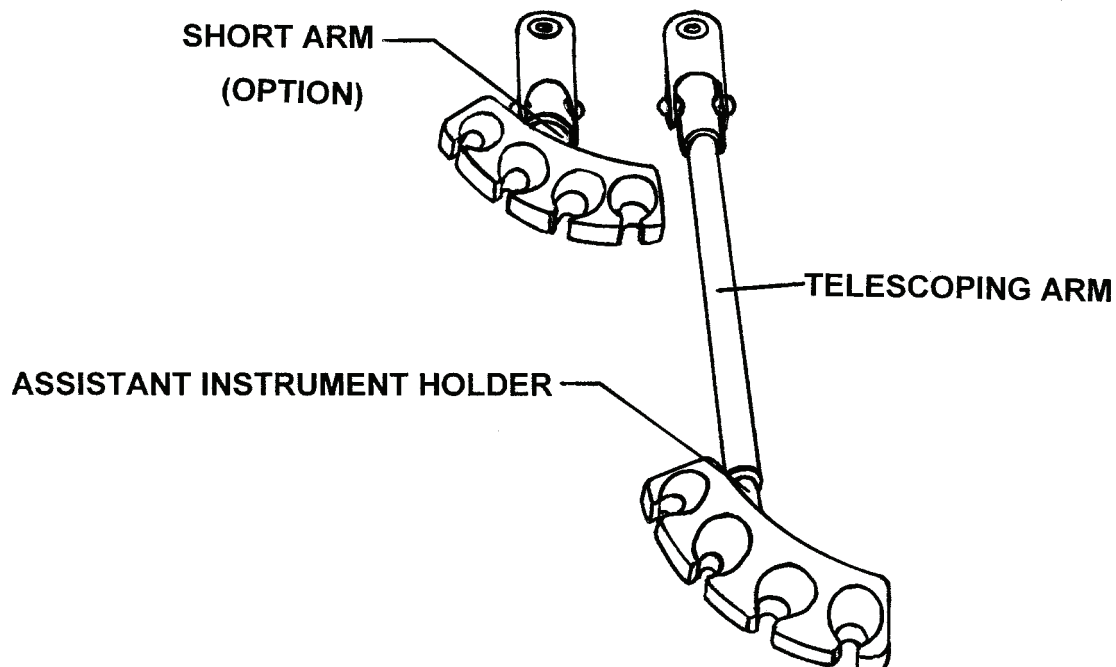

Handpiece Adjustments

Caution: To avoid potential damage to handpieces:

- Never operate a handpiece without a bur in the chuck.
- Do not exceed manufacturers recommended pressure setting at the handpiece.

Check pressure settings at the floor utility before making adjustments: 80 psi Air and 40 psi Water.

Drive Air Adjustment

Each handpiece has a drive air adjustment stem that extends below the underside of the control head.

Lift the hinged control head cover to view the built in pressure gauge. Locate the drive air adjustment stem that corresponds to the handpiece being adjusted.

Install a bur in the handpiece being adjusted. Insert a small screwdriver into the drive air adjustment stem. Fully depress the foot control and adjust the pressure reading on the gauge to the handpiece manufacturers recommended setting.

Note: The reading at the pressure gauge will be approximately 5 psi higher than the actual pressure at the handpiece, due to line loss. To attain the desired handpiece pressure setting, adjust the stem until the gauge pressure is 5 psi above target pressure.

If the adjustment is made using a special in-line gauge attached at the handpiece connector, then set the pressure at this gauge directly, as specified by the handpiece manufacturer.

Coolant Water Adjustment

Each handpiece has an individual water coolant adjustment control, which is located underneath the front edge of the control head. Identify the blue knob behind the handpiece position that is to be adjusted. Turn the knob fully counter clockwise, as viewed from above control head, to close the valve.

Flip the toggle on foot control to switch to the 'wet' position (toggle toward inside of the foot control).

Install a bur in the handpiece to be adjusted. Step on the foot control and run the handpiece.

With the handpiece running, adjust the water coolant flow control until a fine mist is achieved.

CONTROL HEAD

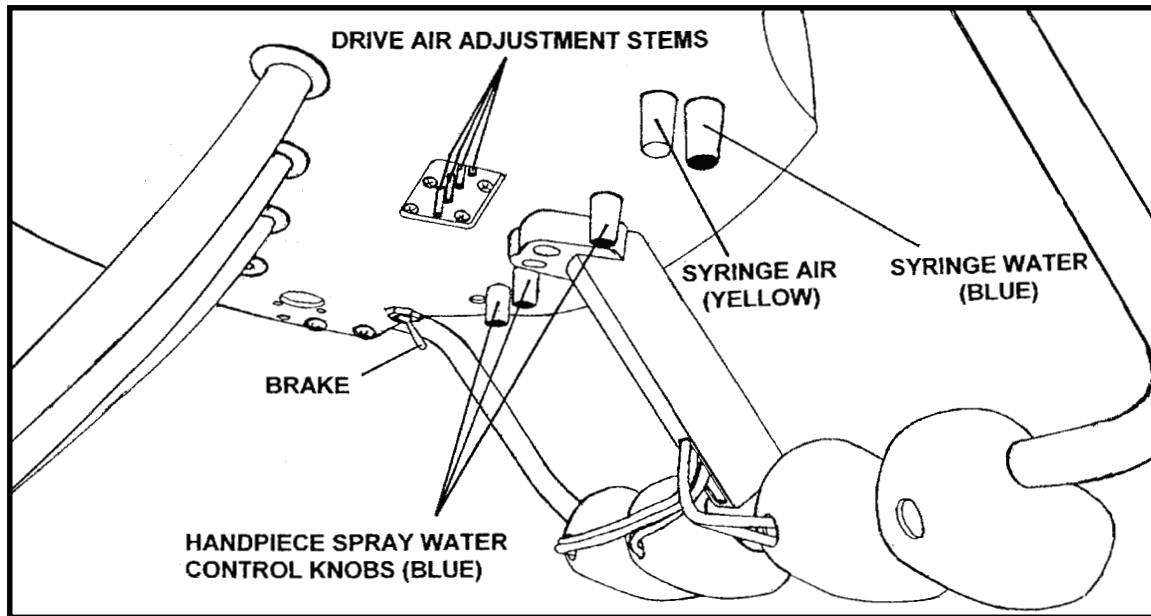

PMU

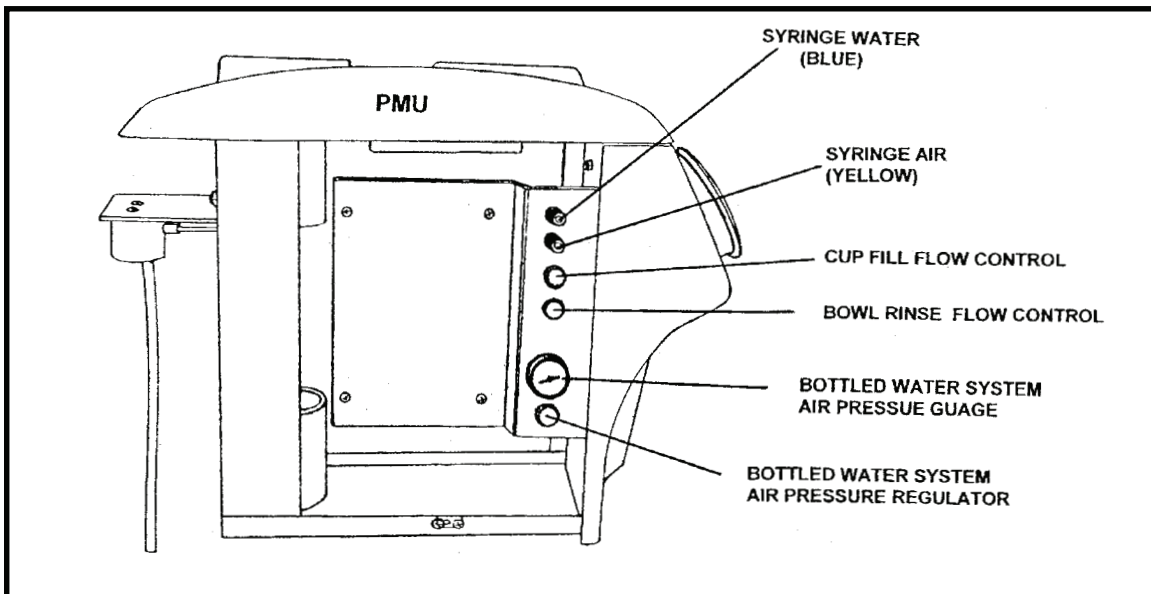

Air Coolant Adjustment

Flip the toggle on foot control to switch to the 'dry' position (toggle toward outside of the foot control).

Install a bur in the handpiece to be adjusted. Step on the foot control and run the handpiece. With the handpiece running, adjust the yellow air coolant flow control on the right side of the control head until the desired flow is achieved.

Syringe Adjustments

Separate air (yellow knob) and water (blue knob) adjustments are located underneath the front left hand corner of the control head for the Doctors syringe and on the control panel *inside* the PMU for the Assistants syringe.

Doctors syringe:

- Direct the syringe tip into a sink.
- Depress and hold the water button on the syringe.
- Adjust the blue knob until the desired water flow is achieved.
- Depress both the water and air button on the syringe.
- Adjust the yellow knob until the desired mist pattern is achieved.

Assistants syringe:

- Remove the black thumbscrews and PMU side cover to access the syringe adjustment controls.
- Follow the same procedures as for Doctors syringe.
- Replace PMU side cover and thumb screws.

CARE AND MAINTENANCE OF THE X-CALIBUR DENTAL UNIT

1) Establish a Maintenance Record

Keeping records of all maintenance activity provides each office with a means of tracking the safety and performance of your dental unit. (See example)

MAINTENANCE RECORD

Unit Installation Date: _____ Installed by (Dealer): _____
Model: _____
Serial Numbers: _____

Daily/Weekly Maintenance

Date:
Performed By:
Description of Activities:

Periodic Maintenance

(Circle) 6 months Date:
 1 year Performed by:
 18 months Description of Activities:
 2 years
 30 months
 3 years
 42 months
 4 years
 54 months
 5 years

2) External surfaces

The complex interaction between the materials of construction of dental units, surface residues, chemical cleaning agents, etc. results in the deterioration of any product. The degree by which this deterioration occurs can vary widely.

The preferred method of protection for external surfaces is by installation of disposable plastic barriers.

If a chemical cleaning agent is the chosen method of sanitization by a dental office, care should be taken to select agents that will eliminate potential damage to the surfaces of your dental unit. **It is of vital importance that the cleaning agent manufacturer's instructions for use are followed.**

It is recommended that external surfaces be wiped down with a mixture of warm water and a mild, non-abrasive detergent following sanitization. This will help remove cleaning agent residues.

Never use sodium hypochlorite or bleach solutions to clean external or internal surfaces as these cleaning agents will damage dental unit components.

Never use abrasive pads or cleaners, as they will damage external surfaces.

3) Water System Care and Maintenance

The dentist should select an accepted waterline sanitizing methodology that reduces bacterial populations to a maximum of 200 CFU/ml (colony forming units per milliliter), as set forth by the ADA.

The selected methodology should be employed daily AND over extended periods when waterlines are stagnant, such as weekends and vacations.

DCI International
 PO Box 228
 305 N. Springbrook Rd.
 Newberg, OR 97132 USA
 503-538-8343
 800-624-2793

Quick Clean Standard Syringe

Syringe Parts

| | | |
|-------|---------------------------------|-----------|
| #0084 | Barb, 8-32 & Washer | (Pkg. 10) |
| #2202 | O-Ring | (Pkg. 12) |
| #2203 | O-Ring | (Pkg. 12) |
| #2211 | O-Ring | (Pkg. 12) |
| #2212 | O-Ring | (Pkg. 12) |
| #2201 | O-Ring | (PKg. 12) |
| #3060 | Syringe Tip | (1 ea.) |
| #3061 | Syringe Tip | (Pkg. 5) |
| #3059 | Syringe Tip | (Pkg. 50) |
| #3065 | Tip Adapter Assembly | |
| #3085 | Button Valve Assembly | |
| #3491 | Handle, Quick-Clean Syringe | |
| #9648 | Pin, Quick Clean Syringe Button | |
| #9670 | Spring, Syringe Button | |
| #9677 | Spring, Tip Adapter | |

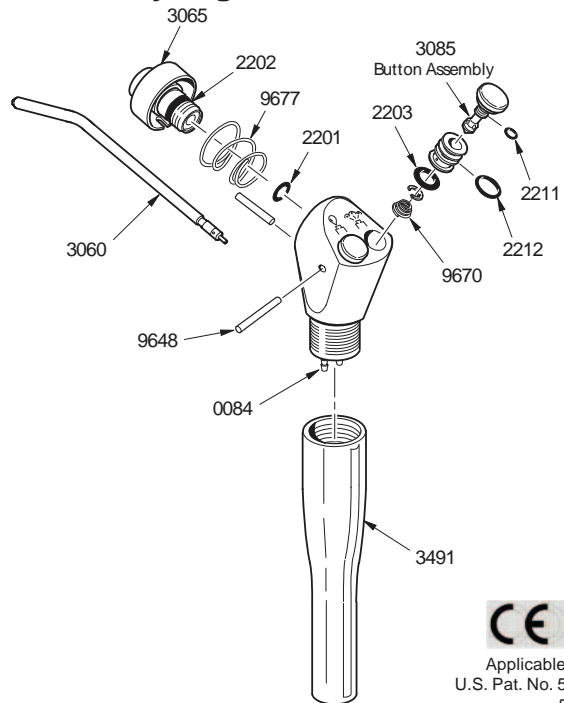

CE 0413

Applicable Patents:
 U.S. Pat. No. 5,125,835
 5,199,871

INSTALLATION

Turn off the air and water supplies. Determine which of the syringe tubes leads to the air button, and connect that tube to the air outlet on the dental unit or syringe manifold. Connect the other tube to the water outlet. For circulating syringes, the third tube is the return water, and is routed to the drain. Recommended operating pressures: Air 80 psi, Water 40 psi.

TIP STERILIZATION

Because there are many types of Autoclaves in use around the world, it is difficult to provide guidance on specific instructions of operating each. Follow the manufacturer's instructions whenever possible.

Be sure to thoroughly rinse and clean tips prior to sterilization, any debris may reduce the effectiveness of the sterilization.

Recommended sterilization process is steam autoclave. Recommended parameters are 125°C (250°F) and 106 kPa (15lb/in²) for 40 minutes at temperature and pressure.

The units of pressure marked on an autoclave's pressure gauge many vary from one autoclave to another.

- 15lb/in² (15 pounds per square inch)
- 106 kpa (106 kilopascals)
- 1 atm (1 atmospher)
- 1 kgf/cm² (kilogram of force per square centimeter)
- 776 torr
- 776 mm Hg (776 millimeters of mercury)

TROUBLESHOOTING & REPAIR

Leakage around the button Replace the button assembly #3085. To remove the button, hold buttons down, remove the retaining pin & gently lift under the button. When re-installing the button, be sure the spring is properly seated, with the smaller end facing upward. While holding both buttons down, insert the retaining pin through the syringe head.

Alternatively, you may replace the O-rings on the button assembly, using Syringe Repair Kit #3066. After removing the button, slide the E-ring from the stem, and pull the button from the spool.

Momentary spurt of water when the air button is pressed Check first to ensure that the syringe tip is undamaged and fully seated in the tip adapter assembly. If it is the O-ring (#2201) under the tip adapter assembly it should be replaced. Remove the tip, and use a 5/32-inch hex key to unscrew the assembly from the syringe head. Use a dental pick or a bent paper clip to remove the small O-ring from the bottom of the bore in the syringe body. Be careful not to nick or scratch the sealing surfaces. The best way to install the replacement O-ring is to slip it onto the end of a syringe tip, apply silicone lubricant, then insert it into the bore.

Before reinstalling the tip adapter assembly, look down into the bore in the syringe body and assure that the alignment pin is in place. With the spring in place in the collar, align the slot in the collar with the pin, then push the collar into the syringe body. Tighten the assembly firmly, holding the hex key by the short end, with the long end inserted into the tip adapter assembly. By holding the hex key this way, you will have approximately the right torque.

Cleaning Syringe Head

Follow ADA recommended Dental office procedures and protocol.

91152 • Rev. B2 • 10/09



**Maintenance and Care
Autoclavable Vacuum Valves**

Prior To Sterilization

Minimize the potential accumulation of debris that could interfere with the operation of the instrument by flushing clean water through it while working the valve lever open and closed several times.

Using mild cleaner and water, wipe all surfaces of the valve and dry with a clean, soft cloth.

Use a stiff HVE or SE cleaning brush of an appropriate size to dislodge internal buildup.

Note: Do not Ultrasonically clean, as instrument surface finishes may be damaged.

Periodic Maintenance

If the operation of the valve becomes sticky or stiff, it may be necessary to remove the valve spool for a thorough cleaning and lubrication. Refer to the appropriate exploded view below.

- 1 Gently lift one end of the plastic on/off lever (V-1103 / V-1203) out from the indentation on the end of the spool.
- 2 Push the spool out of the valve toward that side and completely disengage the lever from the other end.
- 3 Clean the spool and inspect o-rings and replace those that have nicks, cuts, flat spots or show signs of wear. Lubricate o-rings with O-ring lube then reassemble the valve.

Surface Disinfection

Bleach or Sodium Hypochlorite solutions may permanently damage the valve. Some surface disinfectants that will not harm the valve are Birex SE, Sporidicin, Coldspor, Procide Spray, Sterall Spray, Asepti-IDC, Biocide, Promedyne, Iodo-Five, Wescodyne, and Cavicide.

Methods of Sterilization

You may sterilize Belmont Autoclavable Valves by any of the following methods; Chemical Vapor Method, Ethylene Oxide, Steam Autoclave or Dry Heat. Temperatures should never exceed 280 degrees Fahrenheit, or 138 degrees Celsius.

Do not place the instrument in close proximity to the sterilizer heating element. Avoid contact with the sterilizer walls.



5) Cuspidor Drain Line

To prevent the accumulation of solids, thoroughly rinse the bowl and pour several cups of water down the drain AFTER EACH PATIENT. It is recommended that the user flush the drain line DAILY using an environmentally safe biologically active cleaner.

6) Cuspidor bowl rinse and cup fill spouts

The cuspidor bowl should be removed daily for cleaning, using warm water with a mild non-abrasive detergent. Rinse with warm clean water.

Cuspidor bowl rinse and cup fill spouts are removable for cleaning, using warm water with a mild non-abrasive detergent. Rinse with warm clean water.

Twist spouts back and forth when re-inserting to minimize potential damage to O-ring seals.

Note: Spouts are non-autoclavable.

7) Solids Collector

Remove the solids collector screen for cleaning at least once a day. Post Mounted Utility centers use disposable (eight sided) screens that available from Pinnacle (P/N 5509).

8) Bowl Rinse Time Adjustment

Remove the 2 black thumbscrews and PMU side cover. Locate exhaust airflow control valve. Using a small screwdriver, adjust the exhaust air screw clockwise to increase bowl rinse time. Counter-clockwise adjustment decreases bowl rinse time.

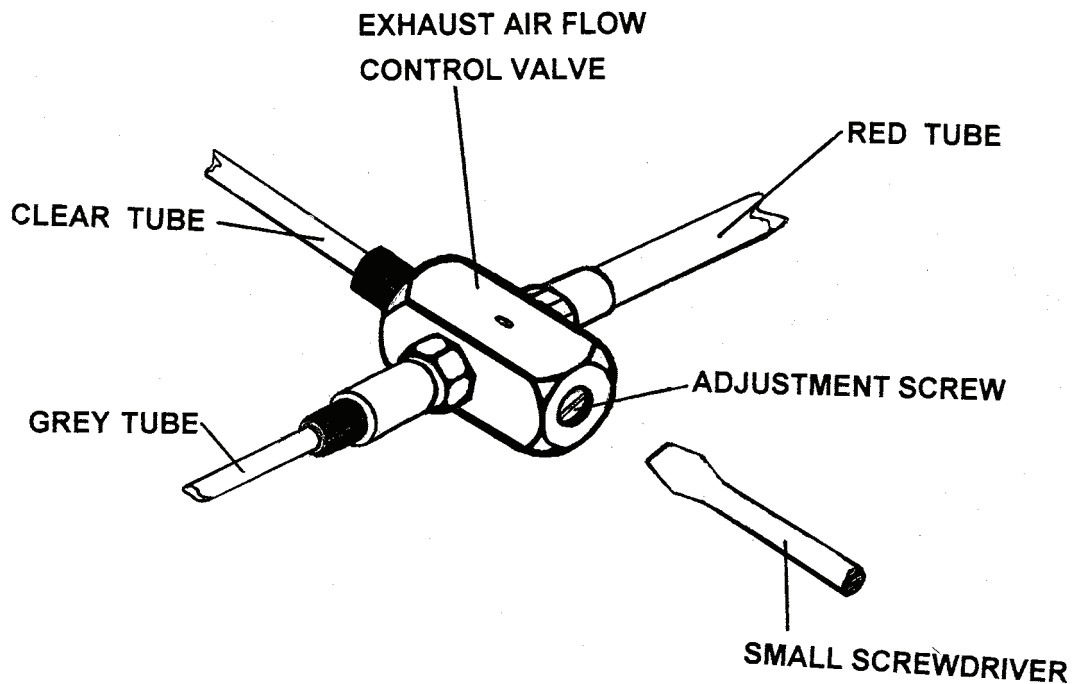

9) Balance Arm Adjustment

Flip the brake switch to the OFF position in order to release the arm brake. Arm should move up and down freely.

Using a Phillips head screwdriver, loosen the screw underneath the end cap from the side of the arm that is attached to the control head.

Remove the end cap and insert an 8-mm Allen wrench into the adjustment bolt. Clockwise rotation will add spring tension and cause the arm to raise. Counterclockwise rotation of the adjustment bolt will cause the arm to lower.

When the balance arm holds position without sinking or raising, tension has been properly set.

Replace the arm end cap and tighten Phillips head screw. Do not over tighten screw.

**BALANCE ARM SHOWN WITH END CAP REMOVED
FROM END NEAREST TO THE CONTROL HEAD**

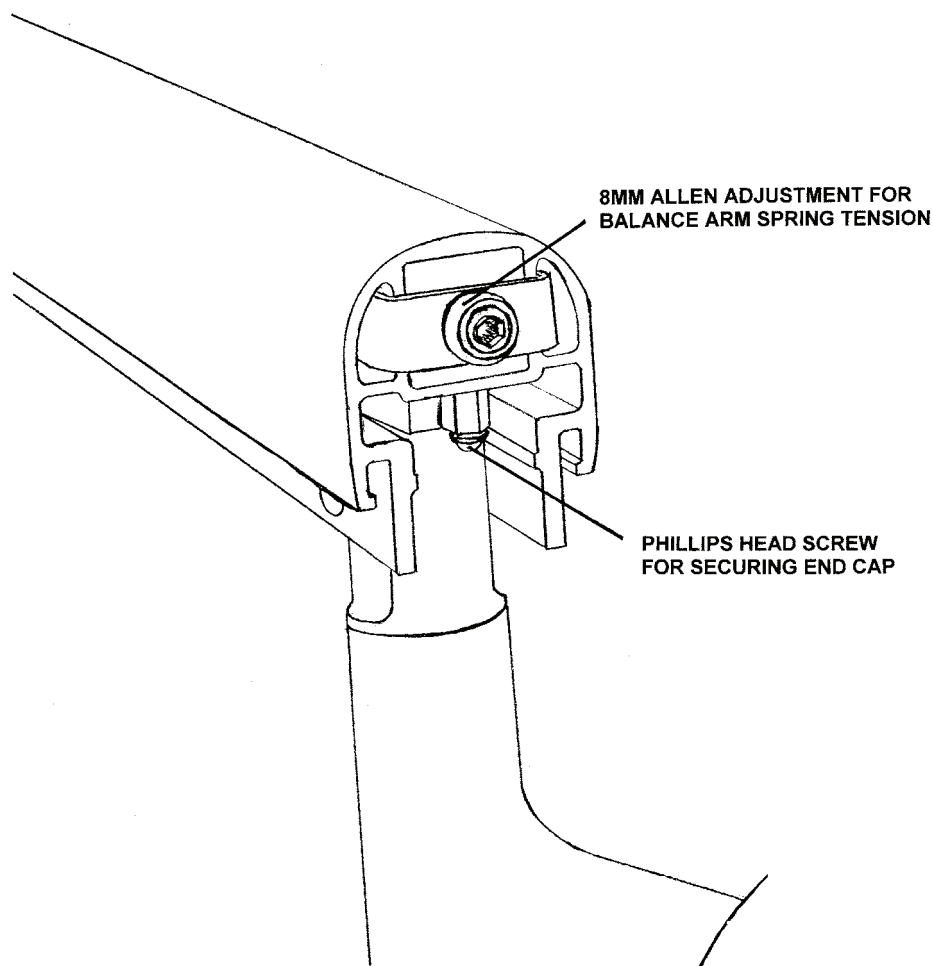

WARRANTY

Belmont Equipment is warranted by the manufacturer to be free from defective material and workmanship under normal use and service, for a period of two (2) years* from date of shipment to the Buyer, except that any part or parts that are replaced under this Warranty within ninety (90) days of the completion of the two year period shall be warranted to be free from defective material and workmanship for a period of ninety (90) days from date of shipment of said parts to Buyer. Belmont will repair or replace any defective part under this Warranty, provided the part is returned to our factory with prepaid postage, delivery or freight charges. In the event Warranty service must be performed to correct any defect, only Belmont and/or one of its authorized dealers shall provide same upon mutually agreeable arrangements made in advance.

Except as otherwise provided herein, there is NO WARRANTY, representation or condition of ANY KIND, express or implied (including NO WARRANTY OF MERCHANTABILITY OR FITNESS) and none shall be implied by law. THE EXPRESS WARRANTY AND THE REMEDIES CONTAINED HEREIN (1) ARE MADE SOLELY TO THE FIRST PURCHASER FOR BENEFICIAL USE (THE BUYER), (2) ARE THE SOLE WARRANTIES AND REMEDIES, (3) ARE IN LIEU OF ALL OTHER WARRANTIES, GUARANTEES, AGREEMENTS OR OTHER LIABILITIES, WHETHER EXPRESS OR IMPLIED, AND ALL OTHER REMEDIES FOR BREACH OF WARRANTY OR ANY OTHER LIABILITY OF BELMONT. IN NO EVENT SHALL BELMONT BE LIABLE FOR CONSEQUENTIAL OR INCIDENTAL DAMAGES.

No person, agent, distributor or dealer is authorized to change, modify or extend the terms of the Warranty in any manner, whatsoever.

This Warranty is void when failure or defect is caused by conditions beyond the manufacturer's control, such as damage resulting from mishandling, neglect, misuse, improper maintenance, accident or alteration or repair by anyone other than Belmont or an authorized Belmont dealer.

Labor required to repair, replace or retrofit is not included during the warranty period by the manufacturer.

*Upholstery Warranty is for one year under normal use and service; upholstery must be cleaned following the instructions provided by the vinyl or disinfecting solution manufacturer.

*Belmont Dental Chairs have a 5 year warranty subject to installation and service qualification. Dental Cabinetry has a 1 year warranty from the date of shipment to the buyer.

*Belmont Dental Units have a 2 year warranty from the date of shipment to the Buyer.

BELMONT EQUIPMENT

A DIVISION OF TAKARA BELMONT USA, INC.

101 Belmont Drive, Somerset, NJ 08873 ■ (732) 469-5000

TOLL FREE (800) 223-1192 ■ FAX (732) 356-1035

www.belmontequip.com