

Installation Instructions & Owners Manual

ECO-Sys Dental Cabinetry
Model: ECO-6/ECO-6L

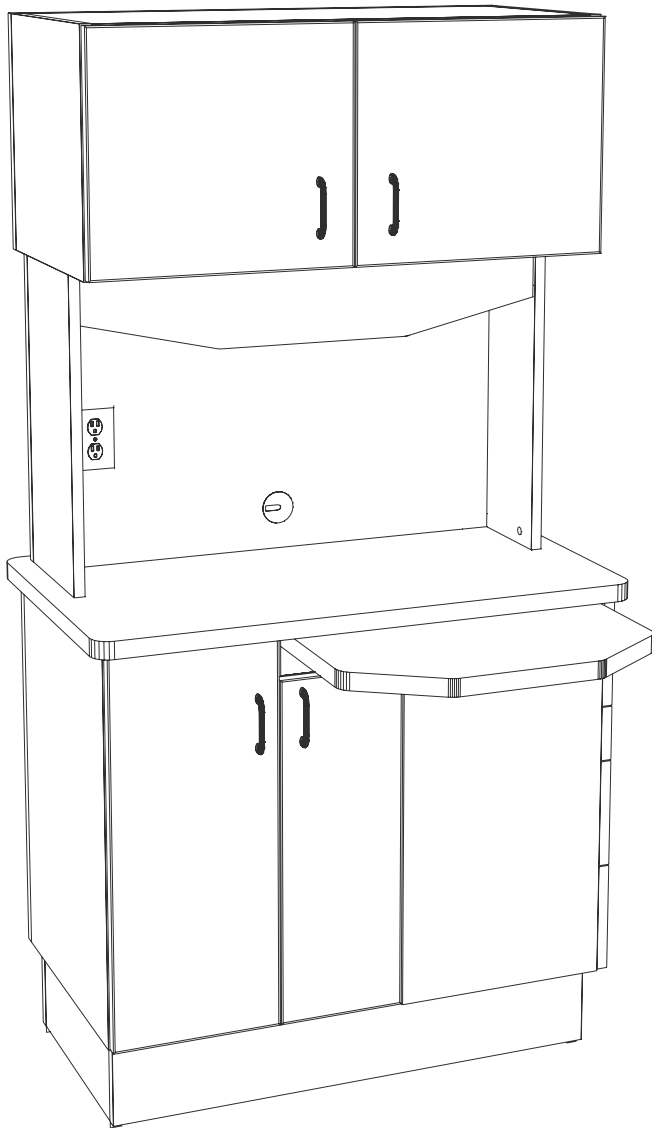

Consumer: Please retain these instructions for future use.

Version: 03252013

 **Belmont**

1631 Dr. Martin Luther King Drive
St. Louis, MO 63106
(314) 231-7383 (888) 833-3682
Fax (314) 621-2296
www.belmontequip.com

Detail Drawings

Model: ECO-6

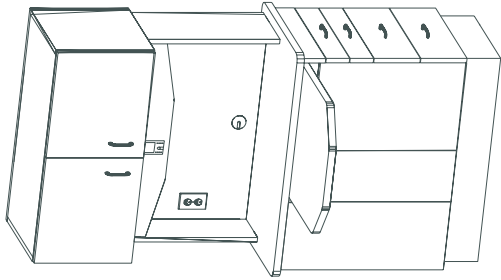

ISOMETRIC VIEW

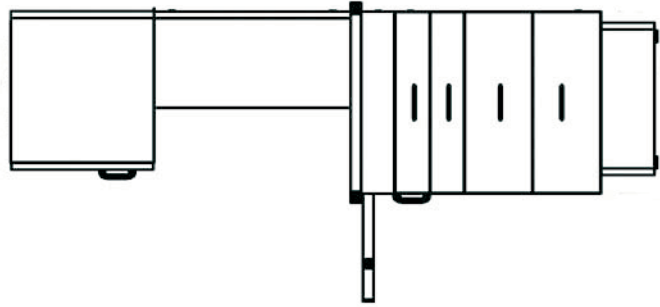

RIGHT SIDE VIEW

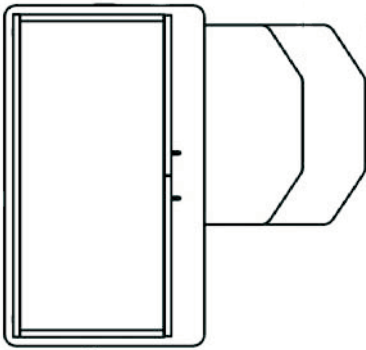

TOP VIEW

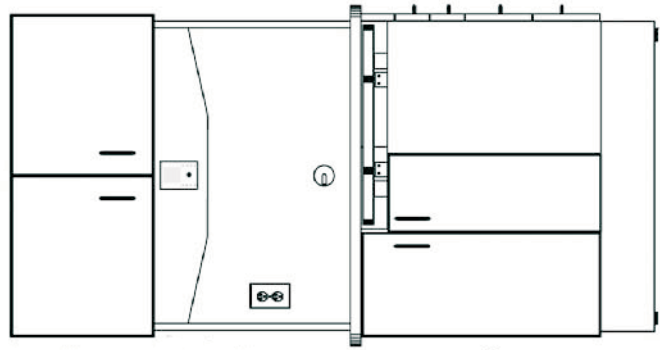

FRONT VIEW

Detail Drawings

Model: ECO-6L

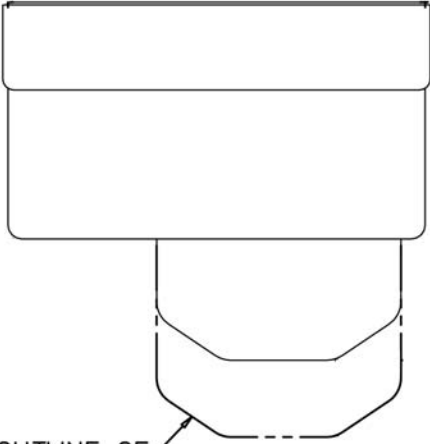

OUTLINE OF
SLIDING TOP
EXTENDED

TOP VIEW

(1) DUPLEX
ELECTRICAL
OUTLET

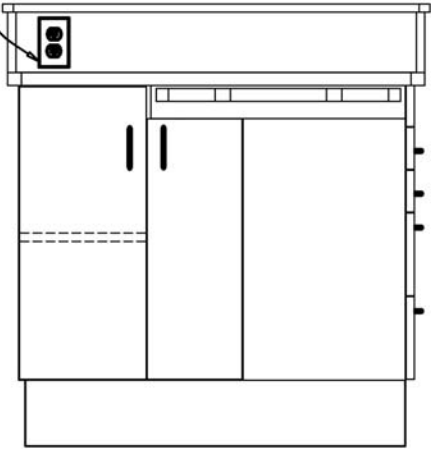

FRONT VIEW

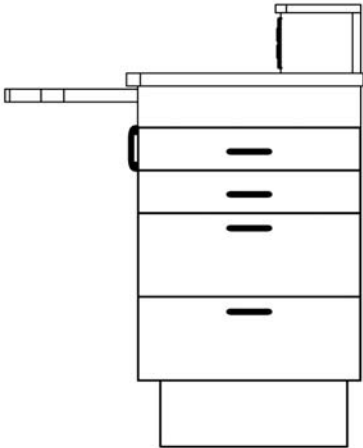

RIGHT SIDE VIEW

General Cabinet Handling Information

Models: ECO-6

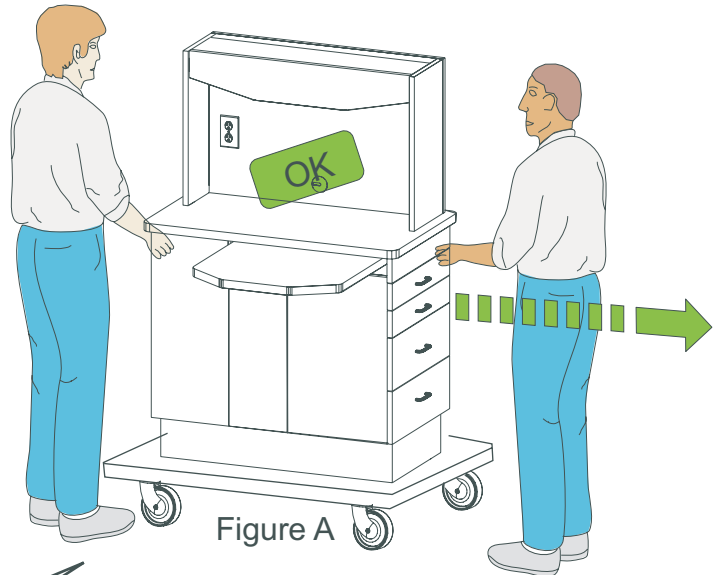

Figure A

Move by using some type of roller dolly, slings or a comparable moving aid. See Figure A and B

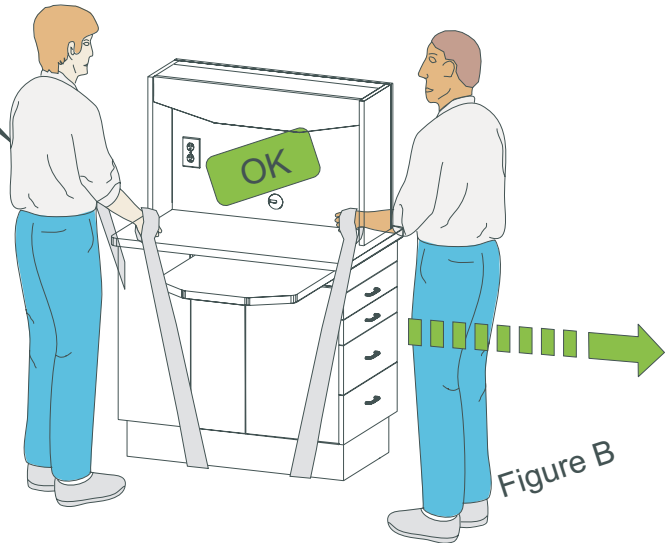
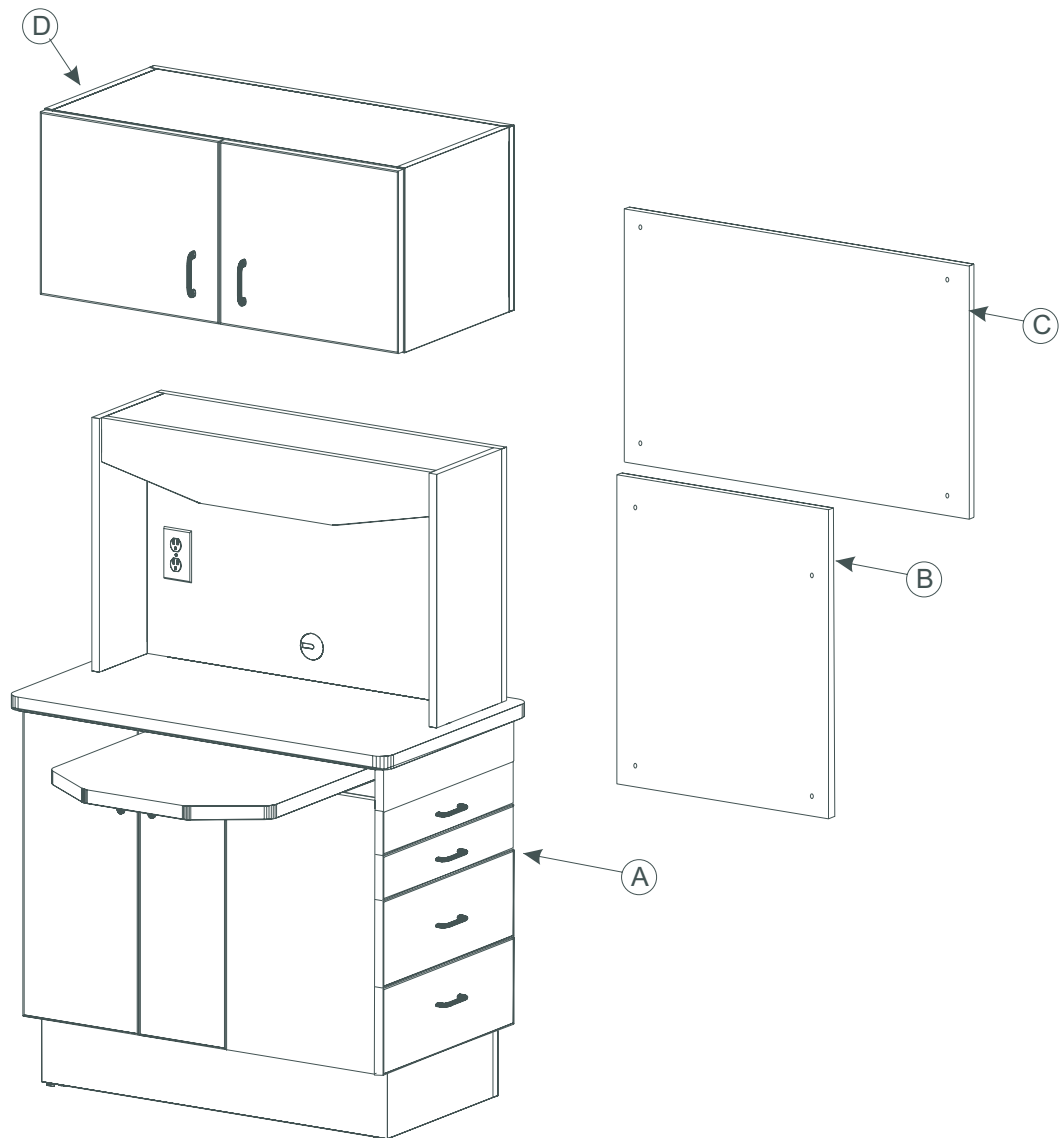

Figure B

Attention: DO NOT lift by Sliding Top which could result in damage to the sliding mechanism.

Assembly Instructions

Model: & ECO-6



Component Identification

- (A) Lower Cabinet
- (B) Lower Back Panel
- (C) Upper Back Panel
- (D) Upper Storage

Note: Back Panels (Item B & C) attached to Lower Cabinet (Item A) during shipping.

Assembly Instructions

Model: ECO-6

Step 1

Check the incoming power location to see if it conforms to the specification on the floor template drawing. If a dental delivery system is to be installed on this cabinet, confirm that the appropriate air, water and vacuum plumbing stubs are in place.

Step 2

Remove (2) Doors (A1) and (4) Drawers (A2) from Lower Cabinet (A) (see Figure 1). Note: Drawers must be kept in order and returned to original locations in order to properly fit.

Remove the (2) Bottom Covers (A3) from inside Lower Cabinet (A) (see Figure 1).

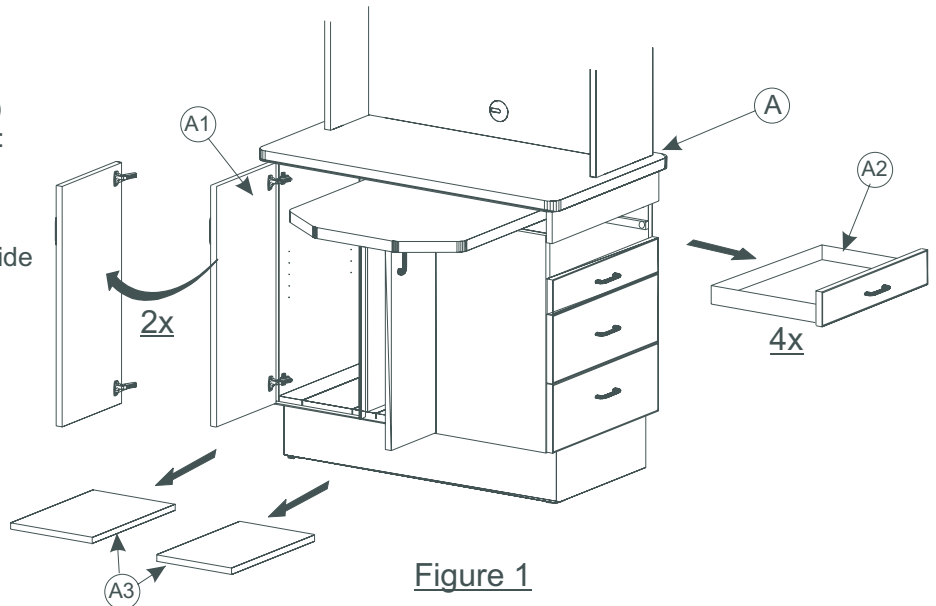
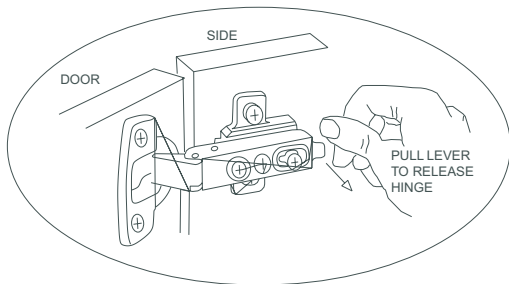

Figure 1

Step 3

Remove Upper/Lower Back Panels (A4) & (A5) by removing (4) Allen Bolts (A6) from each panel using a 4mm Allen Wrench (see Figure 2).

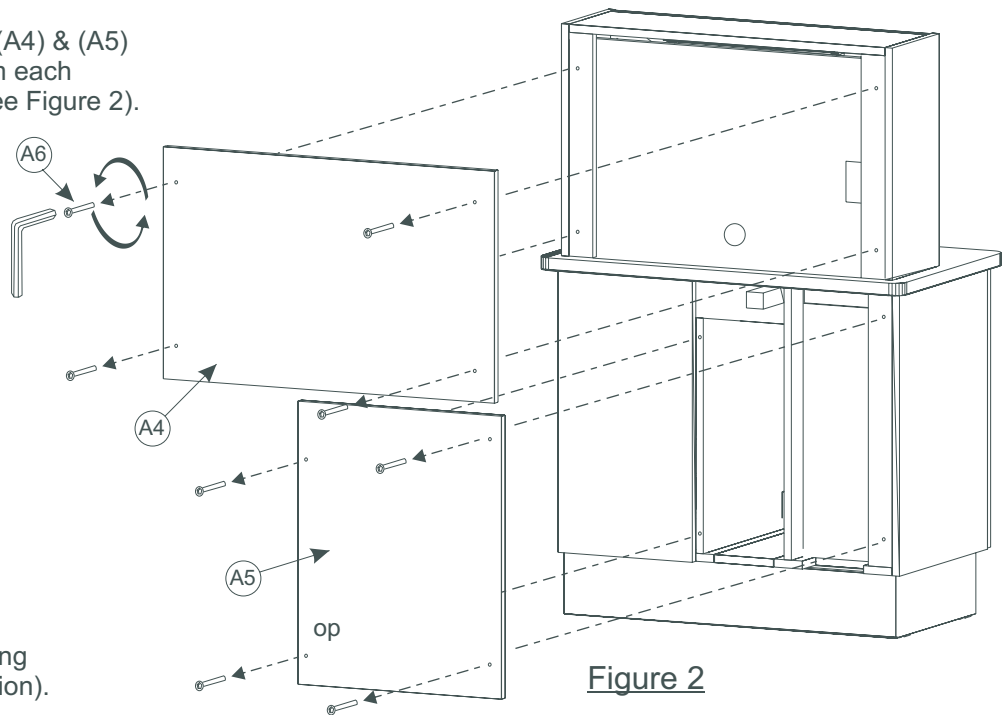

Figure 2

Step 4

Move Lower Cabinet (A) to its desired location (see "General Cabinet Handling Information" page for moving information).

Attention: DO NOT lift by Sliding Top which could result in damage to the sliding mechanism.

Assembly Instructions

Model: ECO-6

Step 5

Remove (2) Doors (D1) from Upper Storage (D) (see Figure 3).

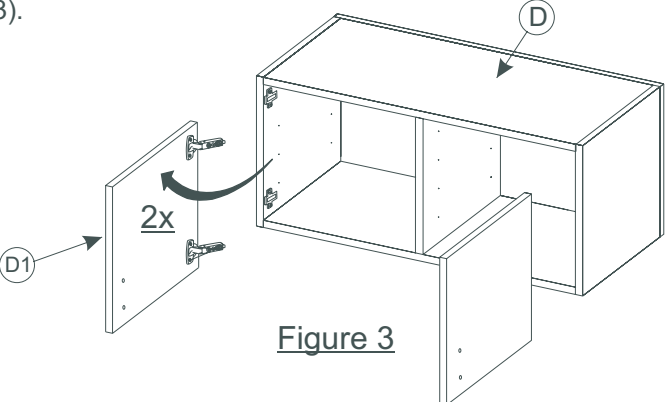
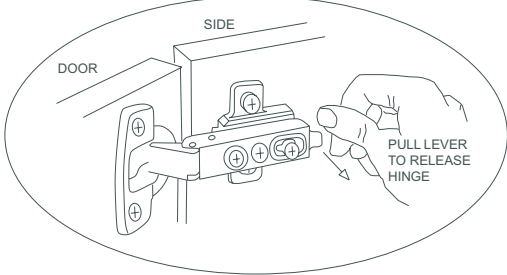

Figure 3

Step 6

Place Upper Storage (D) on top of the Lower Cabinet (A)
Secure with (4) 1/4-20 x 1-3/4" Flat Head Screws (D2) (see Figure 4).
(Note: Make sure to have an assistant hold the Upper Storage in position to keep it from falling off).

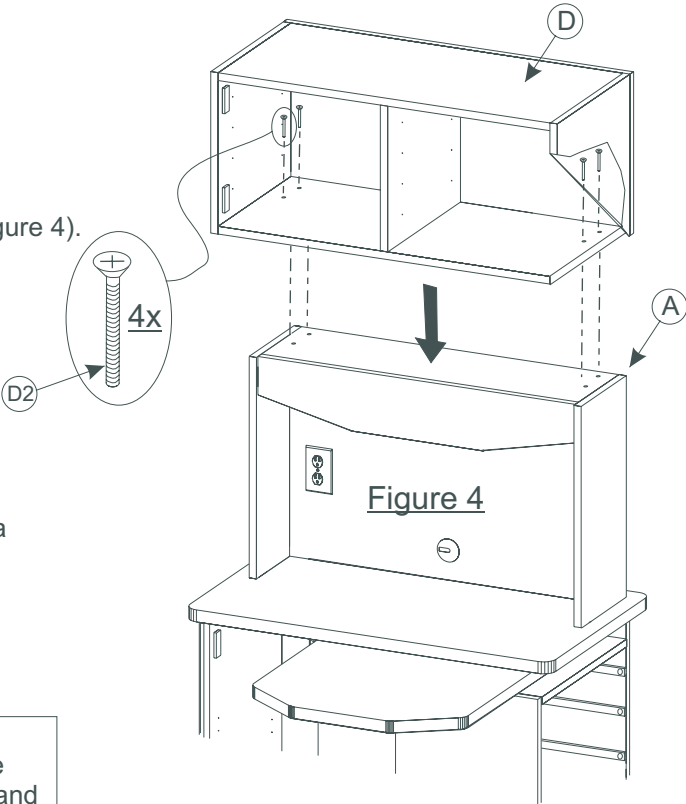

Figure 4

Step 7 IMPORTANT

Adjust the (4) Leveling Feet (A7) to the desired height using a 5mm allen wrench (see Figure 5).

You can mount the cabinet to the floor at this point by mounting the (4) Floor Mounting Brackets (A8) to the floor using proper fasteners for the floor being mounted to.

Both leveling the cabinet and mounting to the floor may be done at a later time but be sure to do so before access to the feet/floor brackets is unavailable (prior to reinstalling covers and panels. Cabinets placed up against a wall is one case where you should wait to mount the cabinet to the floor.

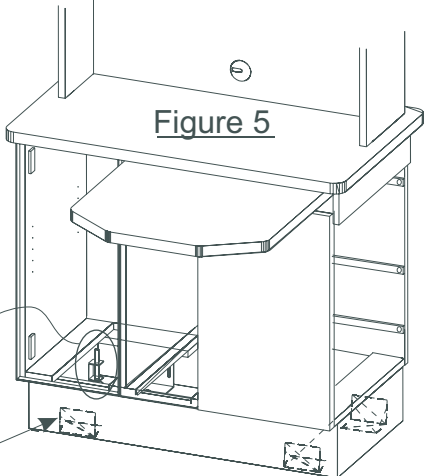
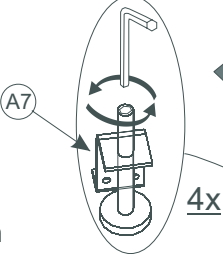

Figure 5

Step 8

Make electrical connections per the ECO-6 Electrical Schematic & Instruction sheets.

NOTE: Cabinets placed against a wall must have electrical access cut through the rear base or Lower Rear Panel.



Assembly Instructions

Model: ECO-6

Step 9A (Optional)

Mount the BDS-2571 Assistant Vacuum Package (shown) underneath the sliding countertop using (4) #10-24 x 1-1/4" allen screws using 5/32" Allen Wrench (see Figure 6). Attach connections according to the unit manufacturers directions.

Step 9B (Optional)

Mount the BDS-2564 Doctors Control Package (not shown) underneath the sliding countertop using (4) #10-24 x 1-1/4" allen screws using 5/32" Allen Wrench. Attach connections according to the unit manufacturers directions.

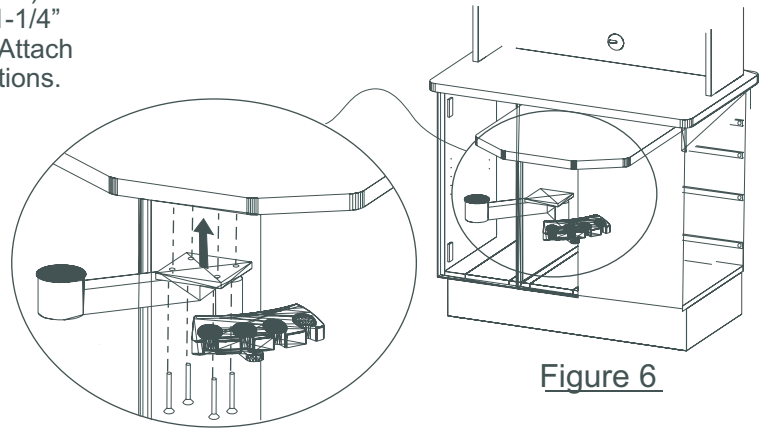

Step 10

Install Upper/Lower Back Panels (A4) & (A5) by securing (4) Allen Bolts (A6) to each panel using a 4mm Allen Wrench (see Figure 7).

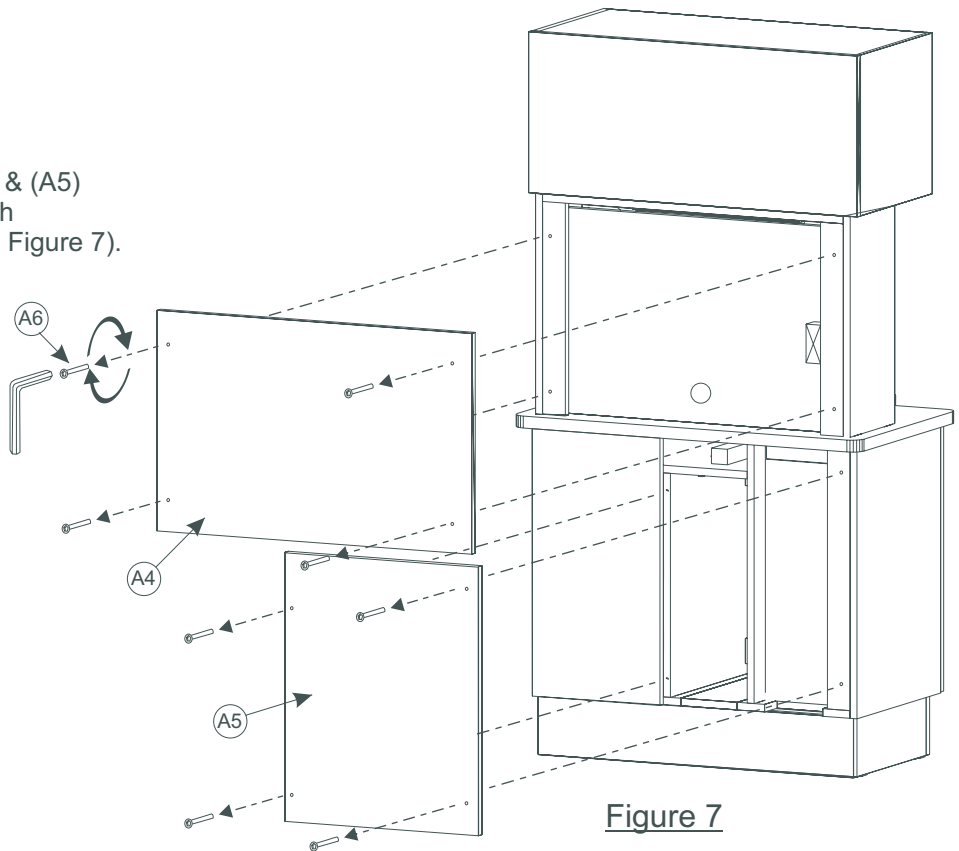

Step 11

Install (4) Shelves (D3) (2 on each side) of Upper Storage (D) by installing (4) shelf pins per shelf into holes on inside panels (see Figure 8).

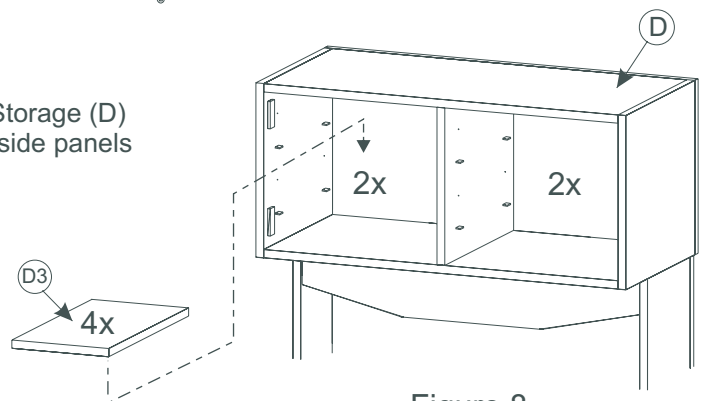

Assembly Instructions

Model: ECO-6

Step 11

Install Upper Storage Doors (D1) to Upper Storage (D) (see Figure 9)
Install Door Handles (D4) to Upper Storage Doors (D1) using
M4 x 25mm Pan Head Screws (D5) (see Figure 9).

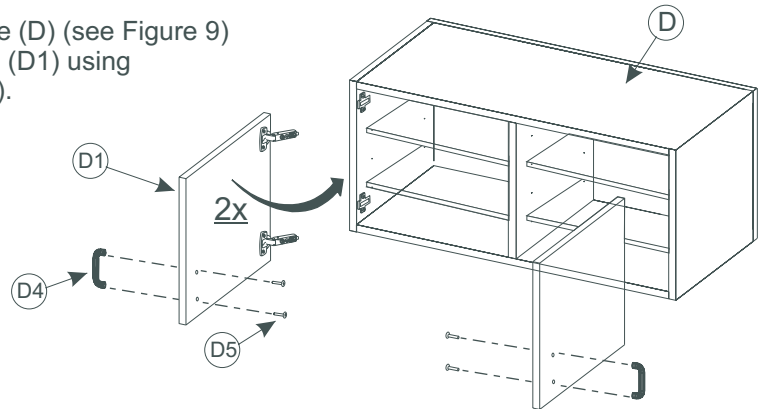

Figure 9

Step 12

Install (2) Bottom Covers (A3) to inside Lower Cabinet (A)
(see Figure 10).

Install Shelf (A7) in Lower Cabinet (A) by installing
(4) Shelf Pins into holes on inside panels
(see Figure 10).

Install (2) Doors (A1) (see Figure 10).

Install (4) Drawers (A2) (see Figure 10).

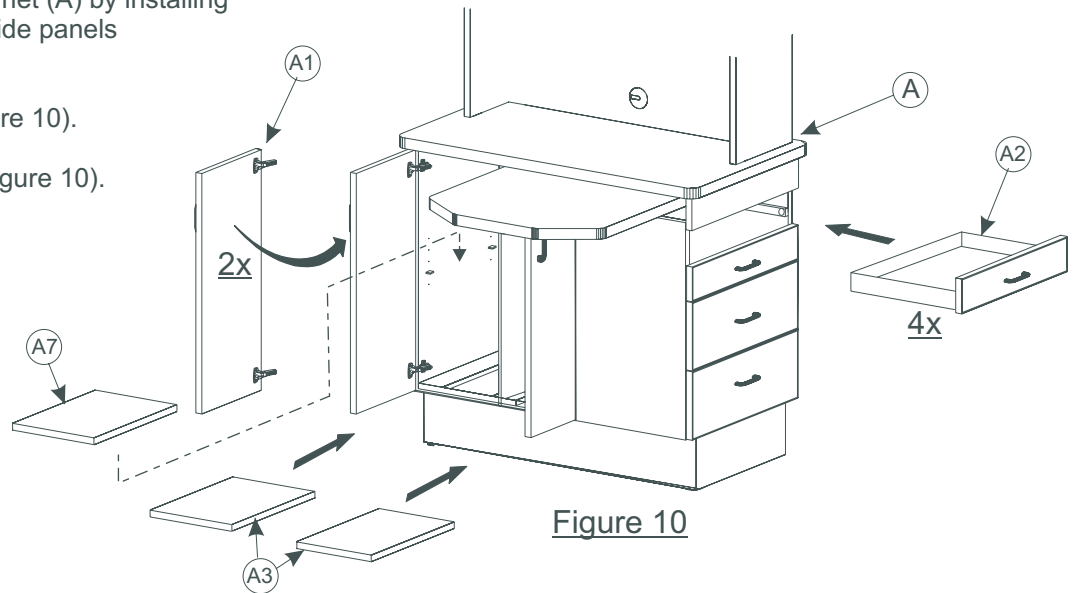

Figure 10

Step 13

Install Clock/Timer (A8) using provided velcro. See Clock/timer
instructions for battery install and operation (see Figure 11).

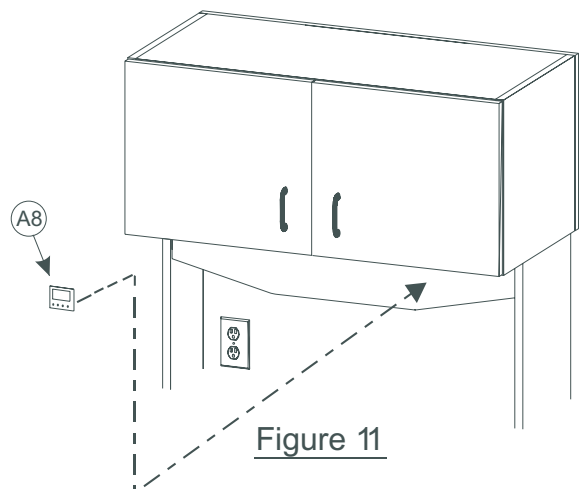

Figure 11

Installation Complete

Filler Panel Installation

Model: ECO-6

If the ECO-6 has to be offset from the wall for drawer clearance or to conceal plumbing, install (2) included Filler Panels as shown below.

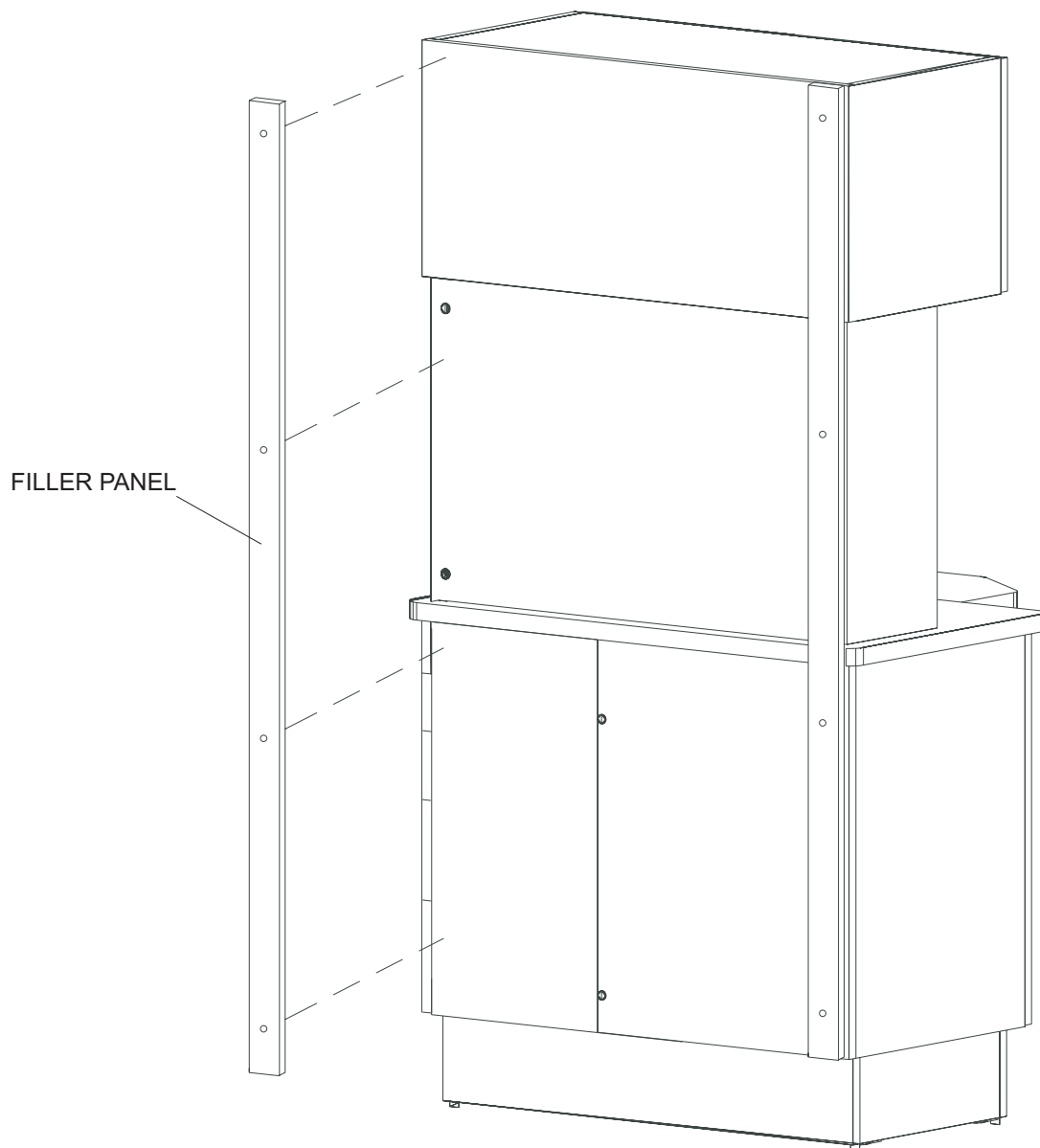

Electrical Schematic
Model: ECO-6

ECO-6 ELECTRICAL CONNECTIONS

ALL ELECTRICAL WIRING MUST BE DONE BY OWNER WITH LICENSED ELECTRICIAN

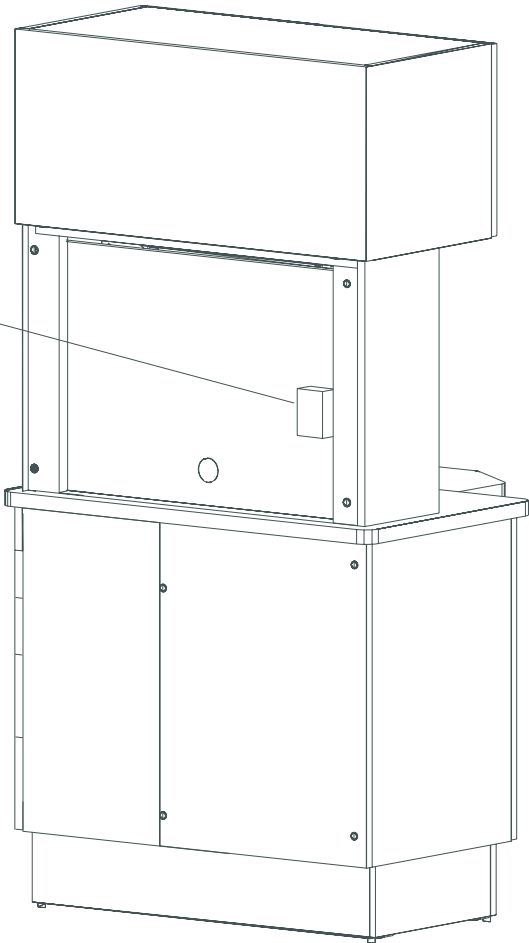
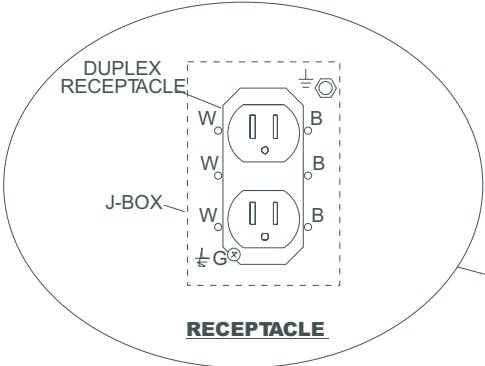

REAR OF CABINET

ECO-6 Electrical Instructions

IMPORTANT NOTE: Approved electrical components are used in the ECO-6 cabinet ; however, the procedures described herein must be performed by a licensed electrician using approved methods and materials according to the local code governing the installation site.

General Electrical Notes

- Each cabinet should be wired to a SEPARATE 15 Amp circuit.
- Unless otherwise specified, ALL WIRING supplied by the contractor must be APPROVED 12 Ga. AWG.
- Disconnect device must be provided in the branch circuit by electrician.

* You have the option of wiring a fluorescent light in this cabinet. Please contact a licensed electrician for consultation.

Hinge Adjustments

Model: ECO-6

Adjustment Instructions for Concealed Hinges and Drawers

3-Dimension Adjustment for Snap-On Hinge

Note: Remove Cover Cap

Allows for three-way adjustments in the hinge arm.
The side adjustment is a micro adjustment. The depth and height adjustment is held by a grid system.

Use #2 POZIdrive screwdriver to adjust screws.

- 1 – Side adjustment
- 2 – Depth adjustment
- 3 – Height adjustment

Release Latch

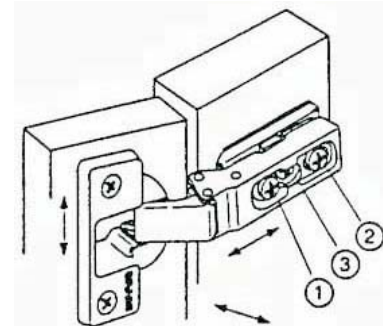

Adjustment for Drawer

- 1 – Height adjustment: Loosen screws **B** slightly. Adjust screw **A** (adjustment +/- 2mm). Tighten screws **B**.
- 2 - Side adjustment: Loosen screws slightly. Adjust front to required position (adjustment range +/- 1.5mm). Tighten screws **B**.

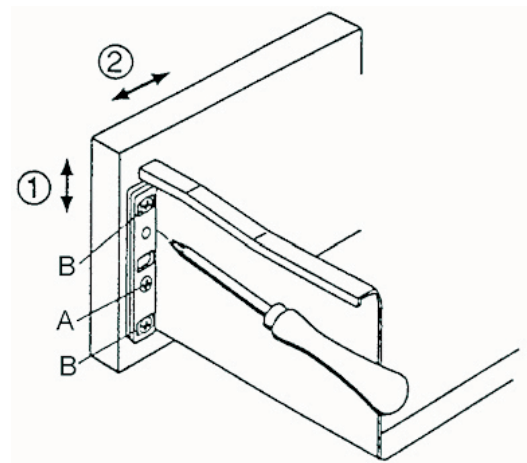

Floor Template

Model: ECO-6/ECO-6L

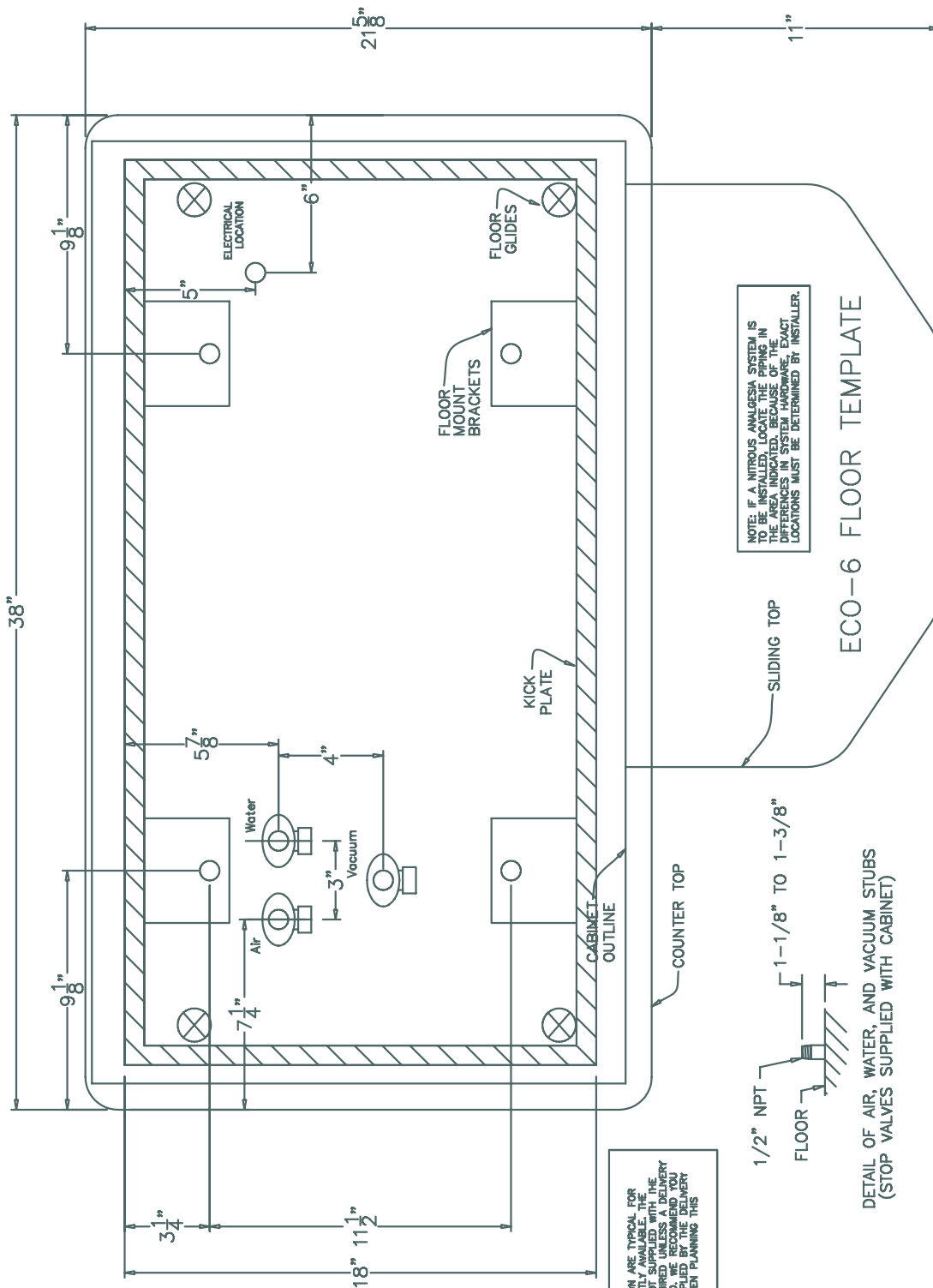

NOTE: IF A NITROUS ANALGESIS SYSTEM IS TO BE INSTALLED, LOCATE THE PIPING IN THE AREA INDICATED, BECAUSE OF THE DIFFERENCES IN SYSTEM HARDWARE, EXACT LOCATIONS MUST BE DETERMINED BY INSTALLER.

ECO-6 FLOOR TEMPLATE

IMPORTANT NOTE: DIMENSIONS SHOWN ARE CRITICAL FOR PLUMBING SCHEDULING CURRENTLY AVAILABLE. THE PLUMBING HARDWARE IS NOT SUPPLIED WITH THE CABINETRY; IT IS NOT REQUIRED UNLESS A DELIVERY SYSTEM IS BEING INSTALLED. STOP VALVES FOR THE ENTIRE SYSTEM ARE SUPPLIED BY THE MANUFACTURER. VERIFY PLUMBING LAYOUT.

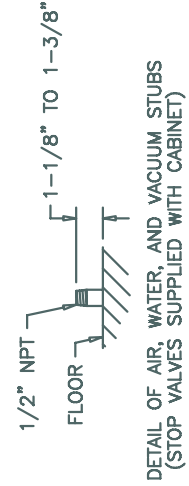

Surface Cleaning

Ortho-Sys. ECO-Sys, D-Series, & E-Series

Belmont Recommends:

- *Countertop Magic*® for Laminate and Solid Surface Work Surfaces
- *Stone Clean and Polish Magic*® for Cambria Quartz Work Surfaces
- *Cabinet and Wood Magic*® for Laminate and Melamine Surfaces
- *Stainless Steel Magic*® for Stainless Steel Surfaces

Products available at Lowes®, Home Depot®, or @ www.magicamerican.com

Laminate/Melamine Surfaces

Clean surfaces with a damp cloth or sponge with a mild soap.

Stains may be removed with most non-abrasive household cleaners such as Formula 409®, Fantastik®, Glass Plus®, or Windex with Ammonia D®.

For tough stains, use a paste of baking soda and water and apply with a soft bristled brush. Although baking soda is a low abrasive, excessive scrubbing or exerting too much force may damage the decorative surface.

Many commercially available products contain substances that may damage or discolor the decorative surface. **Do not** use abrasive cleaners such as toilet bowl cleaners, hydrogen peroxide, oven cleaners, drain cleaners, metal cleaners and polishes, chlorine bleach, coffee pot cleaners, hard water stain removers, fruit and berry juice, tub and tile cleaners, or equivalent.

LG HI-MACS® Solid Surface Tops

Clean surfaces with a damp cloth or sponge with a mild soap.

Stains can easily be removed using a domestic all-purpose cleaner or for tough stains use a bleaching agent (**do not leave in contact with the work surface for more than five minutes**) and rinse with clean water.

Avoid using cleaning agents that contain acids, such as methyl chloride or acetone. Should one of these products accidentally come into contact with the material, as a precautionary measure, rinse the surface with soapy water to prevent any discoloring taking place.

For additional care/maintenance, visit: www.lghausys.com

Cambria® Quartz Work Surfaces

Clean surfaces with a damp cloth or sponge with a mild soap.

Do not use abrasive, strong alkaline, acid, free radicals, or oxidized cleaners (whether high, neutral or low pH). **Do not** use products such as bleach, oven cleaners, Comet®, Soft Scrub®, SOS®, products with pumice, batteries, paint removers, furniture strippers, or tarnish/silver cleaners. **Do not** use abrasive or harsh scrub pads. **Do not** apply sealers, penetrants or topical treatments, as such products will wear off and cause the gloss to appear dull or inconsistent.

For additional care/maintenance, visit: www.cambriausa.com