



EX-2000

PANORAMIC &
Cephalometric X-RAY

INSTALLATION
INSTRUCTIONS

 Belmont

The Belmont logo features a stylized icon on the left, consisting of a square with a smaller square inside it, and the word "Belmont" in a bold, outlined, sans-serif font to its right.

REV. 02

INDEX

SECTION ONE : TECHNICAL DATA	
1) ELECTRICAL AND RADIATION DATA	4
2) MAJOR PARTS IDENTIFICATION	6
3) PHYSICAL DIMENSIONS	7
4) TUBEHEAD THERMAL CHARACTERISTICS	8
SECTION TWO : PRE-INSTALLATION INSTRUCTIONS	
1) CERTIFIED COMPONENT COMPATIBILITY	9
2) SUPPORT REQUIREMENTS	9
3) ELECTRICAL REQUIREMENTS	9
4) LOCATION OF COMPONENTS	10
SECTION THREE : INSTALLATION INSTRUCTIONS	
1) INSTALLATION REQUIREMENTS	10
2) COLUMN/COUNTERWEIGHT ASSEMBLY	11
3) ROTATION UNIT (INCL. HEAD & CASSETTE HOLDER) ASSEMBLY	14
4) CHINREST SUPPORT ASSEMBLY	15
5) CONNECTION OF WIRES	15
6) CEPHALO ARM/CEPHALOSTAT ASS'Y (X-CALIBER CM ONLY)	16
SECTION FOUR : POST-INSTALLATION CALIBRATION	
1) LINE VOLTAGE AND LINE VOLTAGE REGULATION	17
2) TUBE CURRENT	18
3) EXPOSURE TIME	18
4) X-RAY FIELD SIZE AND ALIGNMENT	19
APPENDIX ONE : CERTIFICATION	20
APPENDIX TWO : LAYOUT & FUNCTION OF CONTROLS	21
APPENDIX THREE : CIRCUIT DIAGRAM	22
APPENDIX FOUR : PARTS LIST	23

CAUTION !

This manual provides information and instructions for the installation, assembly, calibration and certification procedures for the “X-CALIBER” panoramic x-ray.

The instructions contained in this book should be thoroughly read and understood before attempting to install the “X-CALIBER” unit. After the installation is completed, file this manual and refer back to it when performing periodic maintenance.

SECTION ONE : TECHNICAL DATA

[1] ELECTRICAL AND RADIATION DATA

1. Maximum rated peak tube potential..... 90 kVp
- 2 RATED peak tube potential 60 - 90 kVp (5 kVp in 7 steps)
- 3 RATED tube current..... 10 mA
- 4 RATED line voltage..... 120 VAC
- 5 Line voltage range 110 - 130 VAC
- 6 Range of line voltage regulation..... 1 - 3 %
- 7 Maximum rated line current..... 10 A at 90 kVp, 10 mA
- 8 Exposure time..... 12 sec. at panoramic mode
15 sec. at TMJ mode
0.3 - 3.2 sec. (15 steps) at cephalometric mode
- 9 Minimum filtration 2.6 mmAl
- 10 Focal point measurement..... 1.0 mm X 1.0 mm

NOTE : Effective focal spot size 0.5 mm X 1.0 mm

- 11 S. I. D..... 490 mm at panoramic & TMJ mode
1650 mm at cephalometric mode
- 12 Duty cycle..... 1:15 (refer to NOTE below)

NOTE : The exposure time in panoramic mode is 12 sec., therefore, 3 min. interval or “Non Use” period requires the user to wait before making another exposure. Because of the 15 sec. exposure time in TMJ mode, 3.75 min. waiting time must be allowed after each series of 2 exposures.

13. Leakage technique factor..... 90 kVp, 0.63 mA

NOTE : 0.63 mA is maximum rated continuous current for 10 mA with a duty cycle of 1 : 15.

14. Film size 6 inch X 12 inch

15. Magnification rate..... 1.25

16. Tomographic orbit Single axis, continuous rotation

17. Nominal roentgen output at the end of beam limiting device*

a. Panoramic mode: 2.3 R/12 sec. $\pm 40\%$ at 90 kVp, 10 mA

b. TMJ mode : 2.9 R/15 sec. $\pm 40\%$ at 90 kVp, 10 mA

NOTE : at the distance of 450 mm from focal spot

18. Half value layer*

- a. Approx. 3.3 mmAl equiv. at 90 kVp
- b. Approx. 2.4 mmAl equiv. at 60 kVp

19. Maximum deviation of tube potential and tube current*

- a. Tube potential : the selected kVp $\pm 15\%$
- b. Tube current : 10 mA $\pm 10\%$

***NOTE :** Approx. variation may be realized to measurement instrumentation, manufacturing tolerances, age, installation variables and use history.

20. Timer accuracy : $\pm 5\%$

21. Measurement basis of technique factors

a. Peak tube potential

The potential difference across the x-ray tube during the conducting half cycle and results in an accuracy tolerance of $\pm 15\%$, as stated below:

From 0 - 0.3 sec., kVp may vary $+35/-45\%$

b. Tube current

The average mA value during a complete power line cycle, results in an accuracy tolerance of $\pm 10\%$, except as stated below:

From 0 - 0.09 sec., mA may vary $+150/-100\%$

From 0.1 - 0.19 sec., mA may vary $+100/-75\%$

From 0.2 - 0.3 sec., mA may vary $+35/-45\%$

c. Exposure time

Impulse time is directly related to power line frequency.

Exposure time applies from the beginning of first conducting line impulse to the end of last impulse, results in an accuracy tolerance of $\pm 5\%$.

[2] MAJOR PARTS IDENTIFICATION

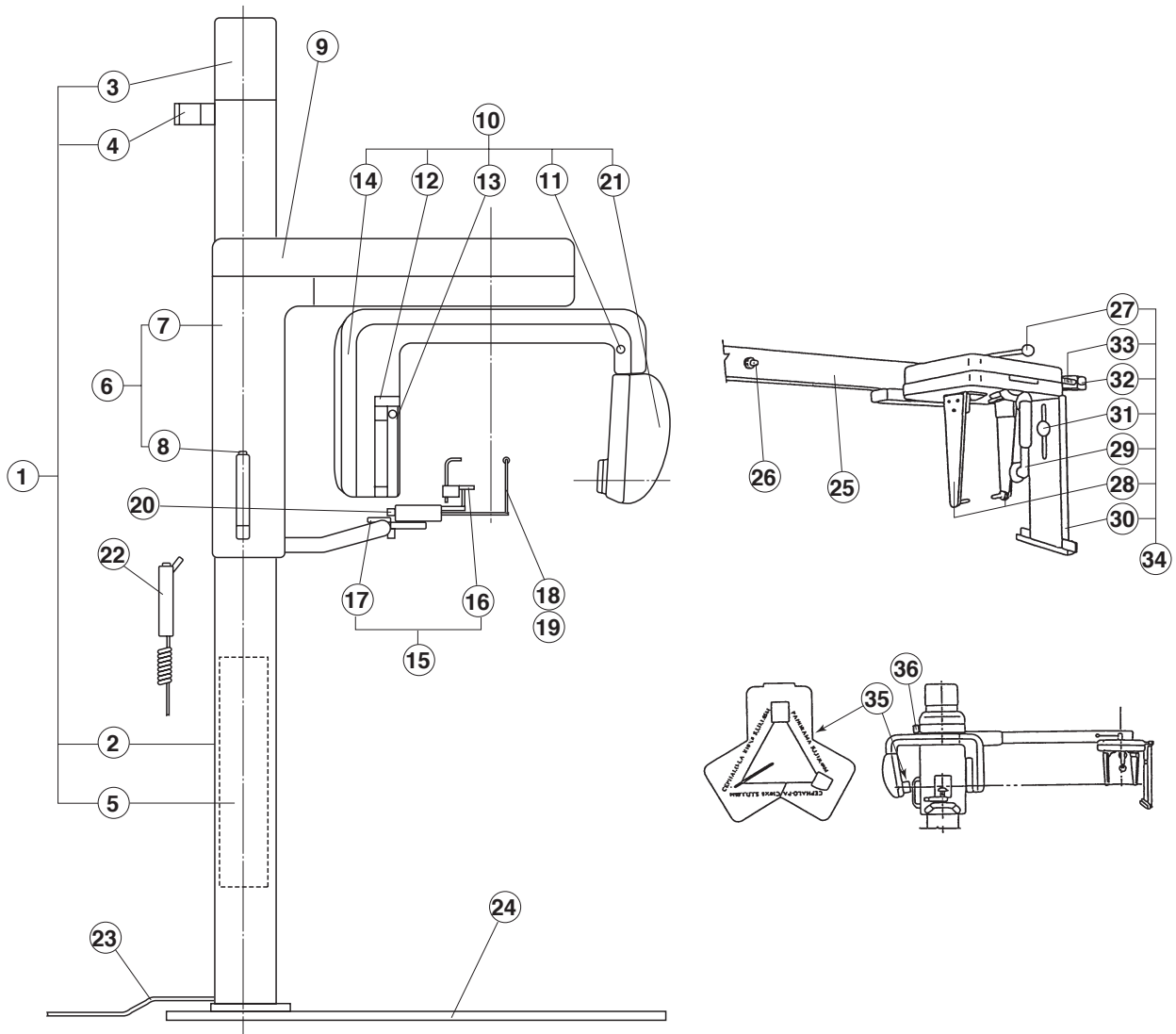

ID No.	DESCRIPTION	ID No.	DESCRIPTION
1	Column Assembly	19	Ear Holding Rod (TMJ)
2	Column	20	Holding Rod Adjuster Knob
3	Top Cover	21	X-ray Head Assembly
4	Wall Bracket	22	Exposure Switch
5	Counterweight	23	Power Supply Cable
6	Sliding Unit Assembly	24	Base Plate (Option)
7	Sliding Unit Body	25	Cephalostat Arm
8	Electro-Magnetic Lock Switch	26	Electro-Magnetic Lock Switch
9	Driving Unit Cover	27	Ear Holding Rod Adjuster Knob
10	Rotation Unit Assembly	28	Ear Holding Rod (Cephalo)
11	Reset Switch	29	Forehead
12	Cassette Holder Assembly	30	Cassette Holder
13	Shield Plate	31	Cassette Holder Knob
14	Cover for Controller	32	Cassette Position Lock
15	Chinrest Assembly	33	Cassette Position Scale
16	Chinrest	34	Cephalostat Assembly
17	Chinrest Adjuster Knob	35	Beam Limiting Device
18	Head Holding Rod (Panorama)	36	Rotation Lock

[3] PHYSICAL DIMENSIONS

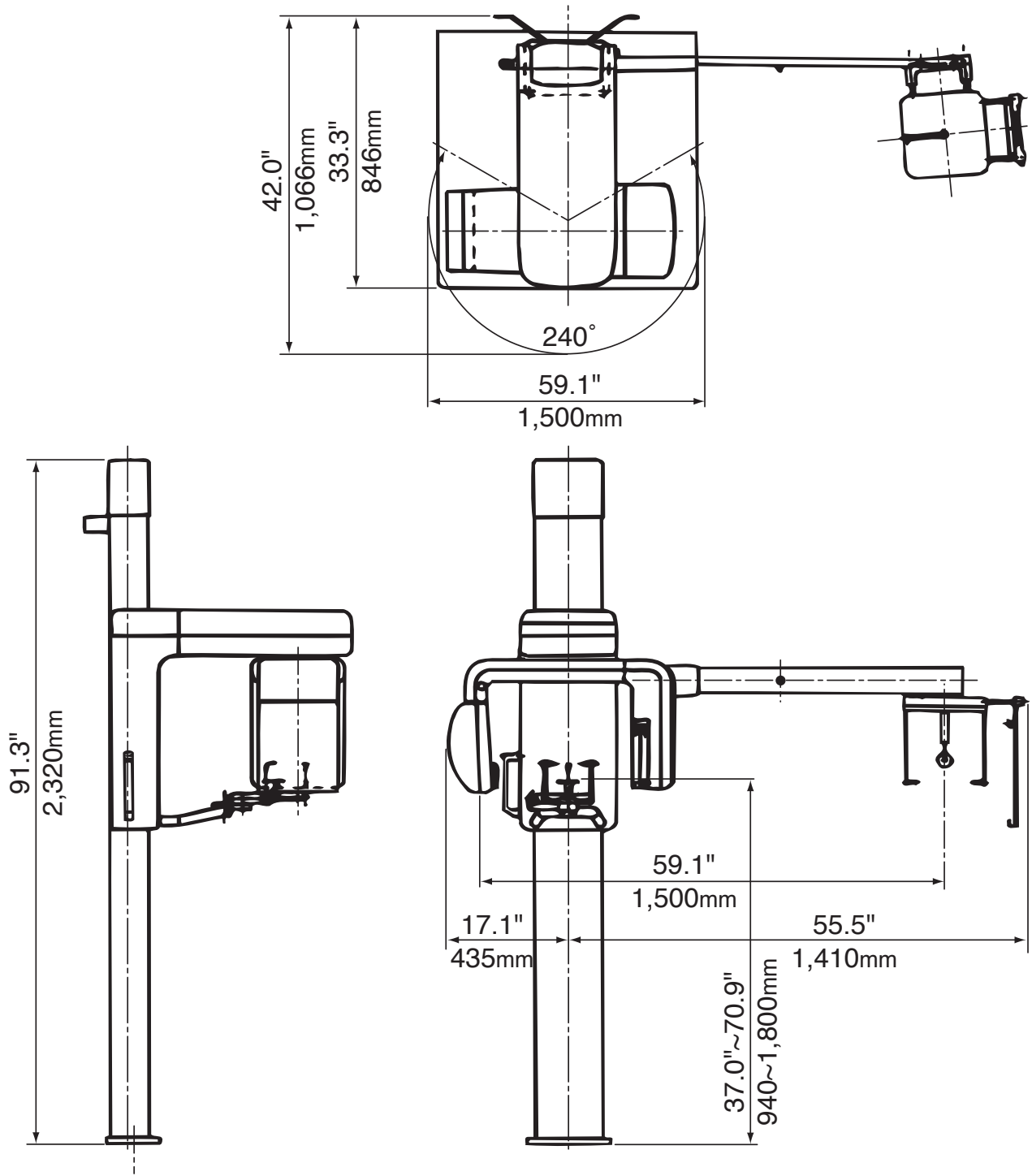

[4] TUBE HEAD THERMAL CHARACTERISTICS

A. INTERVAL BETWEEN EACH EXPOSURE

The temperature inside of the tube head rises when an exposure is made.

The value of the heat generated is measured in Heat Units (HU), which is the product of tube potential, tube current and exposure time. Excessive heat may damage the x-ray tube, high voltage generator or both.

B. DUTY CYCLE

To avoid the accumulation of excessive heat in an effort to prolong the tube head life, a cool down interval of 3 min. at panoramic mode or 3.75 min. at TMJ mode must be allowed between each exposure.

C. TUBE HEAD COOLING CURVE

1. Tube housing cooling curve

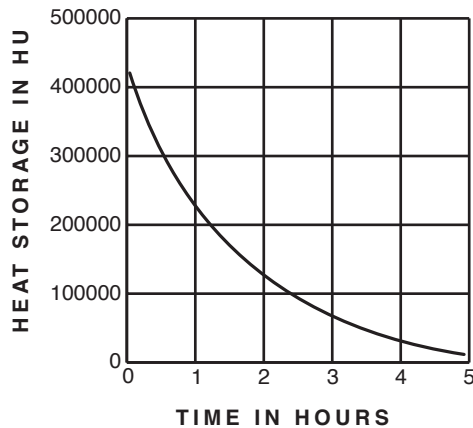

2. Anode thermal characteristics curve

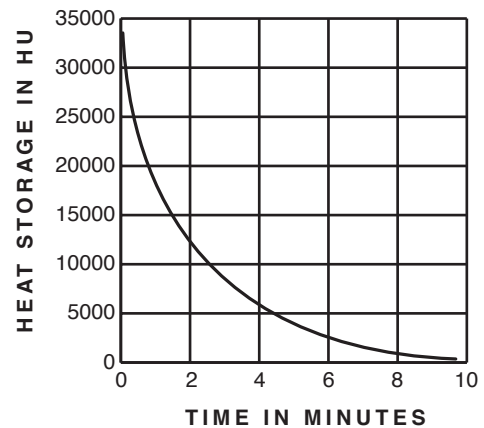

3. Maximum rating chart

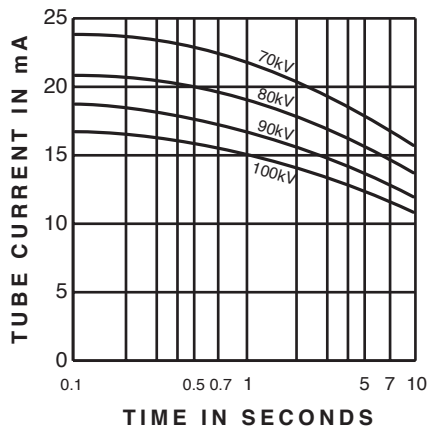

SECTION TWO : PRE-INSTALLATION INSTRUCTIONS

[1] CERTIFIED COMPONENT COMPATIBILITY

COMPONENT	MODEL DESIGNATION	LABEL LOCATION	COMPATIBILITY
Tube head	X-CALIBER-H	head housing	none
Control box	X-CALIBER-C	panel side	none

[2] SUPPORT REQUIREMENTS

- 1) The X-CALIBER unit must be securely bolted to the floor with 3/8 inch diameter fasteners appropriate to the floor construction (lag screw into concrete, etc.)

NOTE : IN GENERAL, MAJOR STRUCTURAL MODIFICATIONS ARE NOT REQUIRED. HOWEVER THE FLOOR ON WHICH THE X-CALIBER CM IS PLACED SHOULD BE ABLE TO SUPPORT 600 lbs. DEAD LOAD.

- 2) Upper bracket must be attached to wall studs with minimum of two 5/16 x 3 inch lag screws. Pre-bore holes with a maximum 3/16 inch diameter.
If studs are not available at the appropriate installation point or if stud wall construction is not used, a rigid structure capable of supporting 100 lbs. pull out must be provided.

NOTE : DO NOT USE THIS UNIT WITHOUT CORRECT BRACING.

- 3) Screw slots are oversized to allow for positioning/levelling. Appropriate washers must be used on all fasteners.

[3] ELECTRICAL REQUIREMENTS

1) POWER SUPPLY

The X-CALIBER panoramic x-ray will operate on a power supply of 120 + 10 VAC. A three wire GROUNDED circuit, separately connected to the central distribution panel with an over current protection device rated for 20 amperes. Recommended wire size is 12 AWG. But if the wire run distance is to exceed 50 feet, 10 AWG is required. For wire run distance in excess of 75 feet, up to 125 feet, 8 AWG is required. Line voltage regulation must exceed 3 % at 12.5 amps.

- 2) All connections, workmanship and materials used must comply with the national Electric Code and local codes.

[4] LOCATION OF COMPONENTS

NOTE : STATE AND LOCAL REQUIREMENTS SUPERSEDE GUIDE LINES INDICATED BELOW.

When determining the location for the X-CALIBER unit, the following radiation requirements concerning operator's positioning must be considered.

The operator must:

1. Have full view of the patient.
2. Have full view of the technique factors before the exposure begins.
3. Be a minimum of 6 feet away from the source of radiation.
4. Be out of line of the useful beam of radiation or be positioned behind a protective device with x-ray protection equivalent of 1 mm of lead.

Considering the conditions above, determine the correct location for the installation of the X-CALIBER unit.

SECTION THREE : INSTALLATION INSTRUCTIONS

Within the installation and calibration procedures are inspection/test steps which the installer must perform to insure that the installation meets the manufacturer's specifications. These steps are identified as "TEST" steps on the following pages.

[1] INSTALLATION REQUIREMENTS

1) TOOLS

- * Standard tool kit
- * Metric allen keys
- * Jeweler's screw driver

2) INSTRUMENTS

- * Digital multimeter with an accuracy of 1%, capable of measuring 150 VAC and 20 mA DC, and capable of indicating true RMS value within one second (Fluke 8026B or equivalent)
- * Voltage impulse counter, capable of registering 1 to 999 half wave primary voltage impulses at a rate of 60 per second over a range of 90 to 100 Vrms 60 Hz

[2] COLUMN/COUNTERWEIGHT ASSEMBLY

1) Lay the column face up as shown, supporting it with approximately 6" of lumber covered with cloth, at the top end.

Put the bottom cover over the column and slide it down all the way to the bottom of the column.

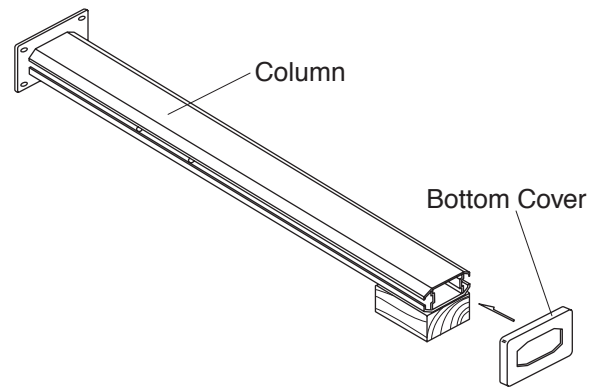

2) Remove rear-side cover plates of sliding unit by loosening three screws on each plate, then slide the sliding unit over the column and move it downward.

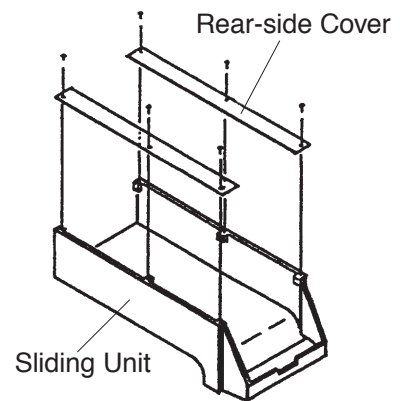
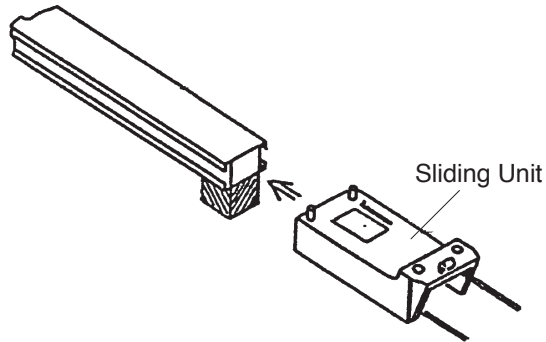

3) Turn the column face down as shown. Insert the steel rod (provided) into lower hole on column sides.

NOTE: There are two pairs of holes on the column sides. At this point, steel rod should be inserted lower holes.

Remove rear cover of column.

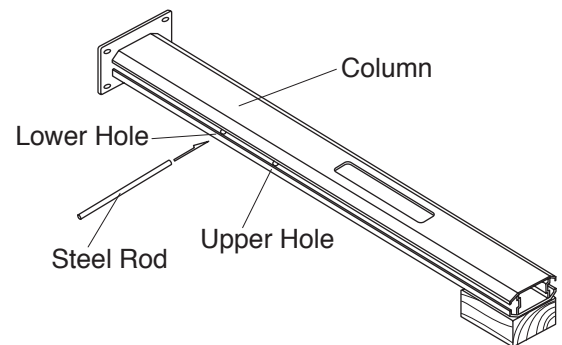

4) Remove two covers of counterweight frame, and insert the counterweight frame into column half the way.

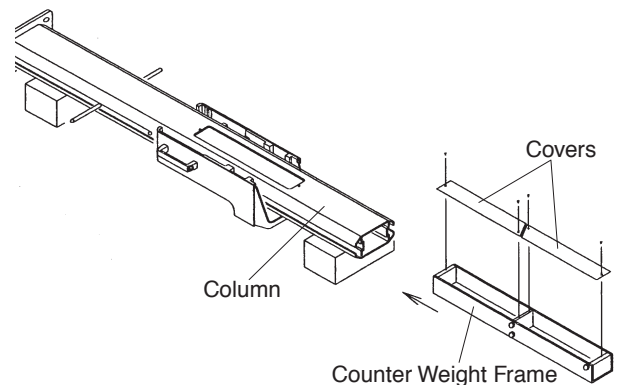

5) Attach wire cable to the top of counterweight frame with two blocks as shown.

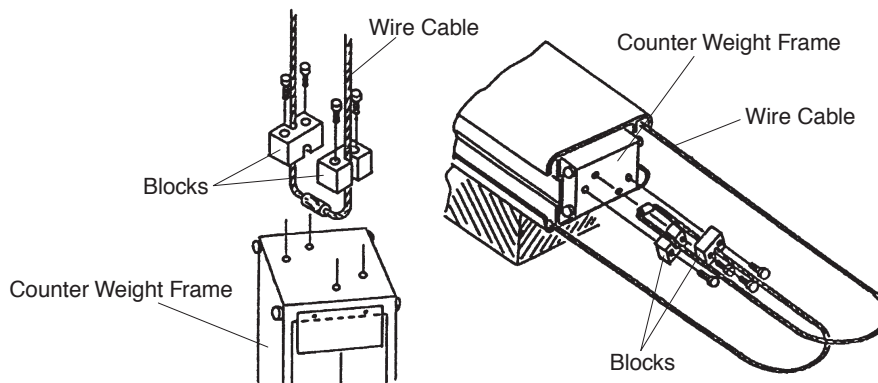

6) Push down the counterweight frame until it hits the steel rod, and set the counterweight and adjusting weights in the upper box of the frame. Attach one cover of counterweight frame.

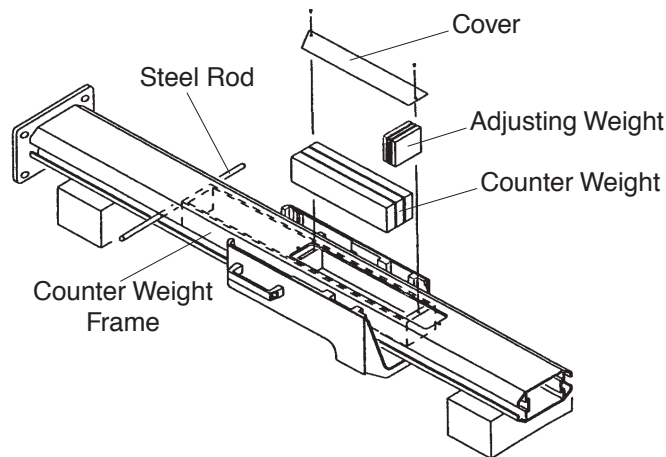

7) Pull up the counterweight frame by pulling wire cable so that lower box of the counterweight frame meets the cutout on the column. Set the counterweight and adjusting weights in lower box of the frame. Attach the other cover of counter

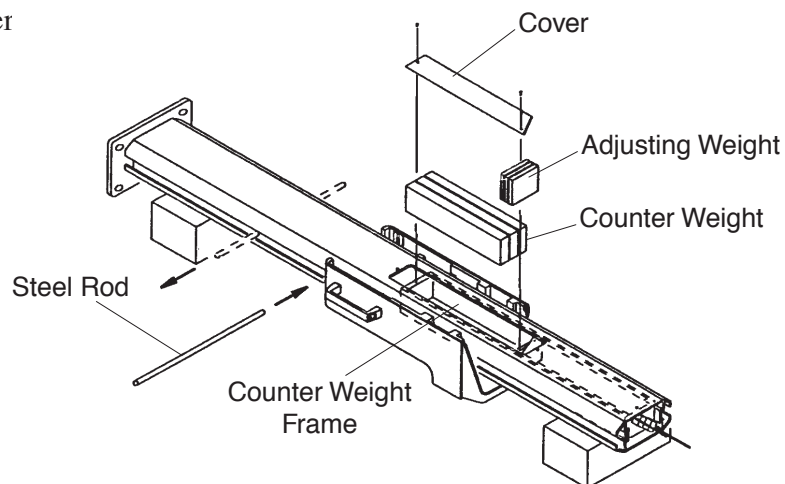

8) Pull out the steel rod from lower holes and insert it into upper holes. Push down the counterweight frame until it hit the rod.

9) Attach wall bracket on top of the column.

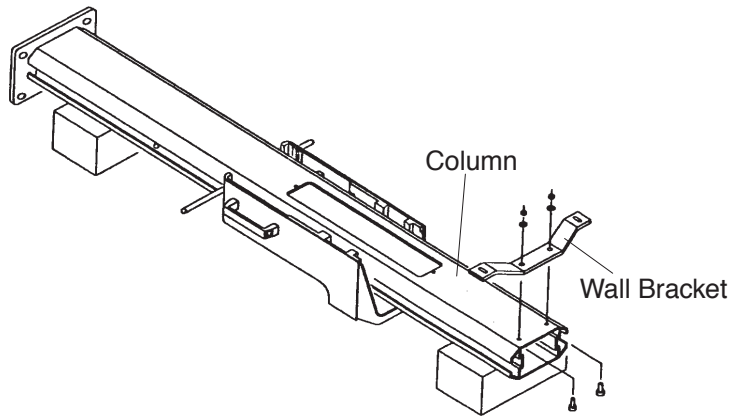

10) Attach pulley assembly on top of the column, and pass the wire cable of counterweight over the pulleys.

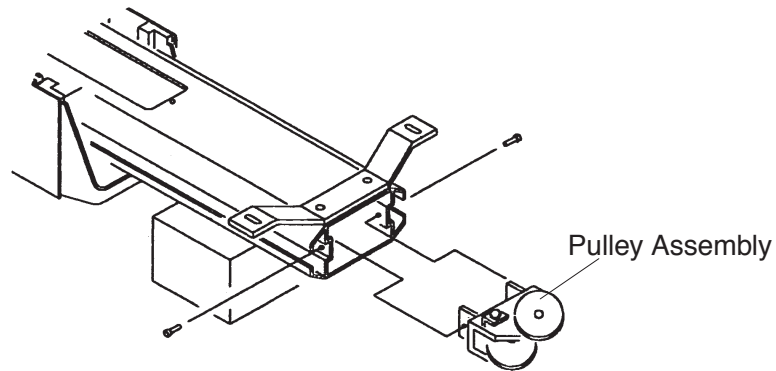

11) Slide down the sliding unit until wire cables are fully extended.

12) Attach rear cover of column and two rear side cover plates of sliding unit.

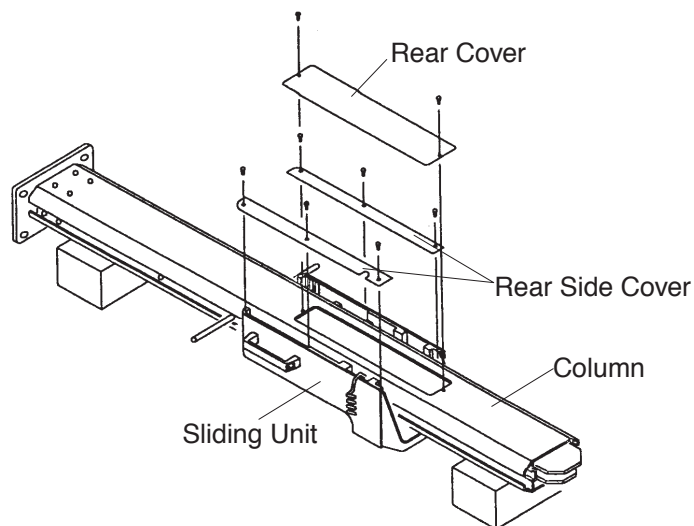

13) Erect the column and mount it on the floor.

[3] ROTATION UNIT ASSEMBLY

1) By holding carriage holders with two men, hook the rotation unit ass'y onto the sliding unit.

NOTE: To make this job easier, it is recommended to pull down the sliding unit, and reinsert the steel rod into upper hole so that counter weight frame rests on the steel rod (sliding unit stays at lower position).

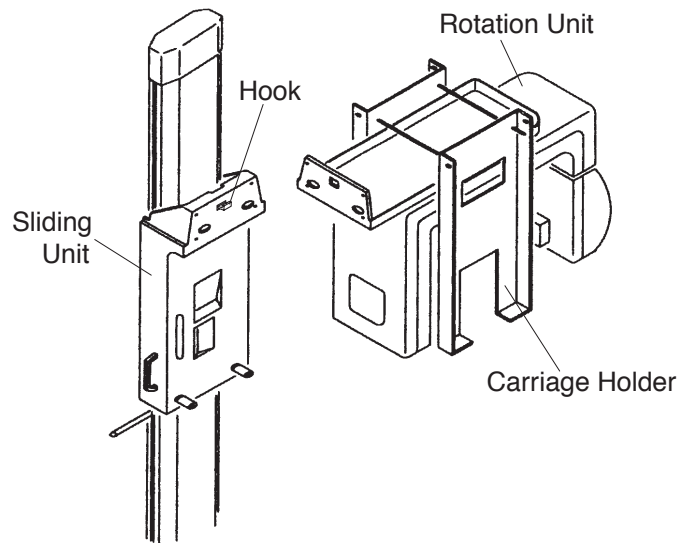

2) Pull out the electrical connectors from the sliding unit, and lead cable through the hole on rotation unit body.

3) Insert taper pins with a hammer.

NOTE: When knocking taper pins, be sure the nut on each pin is fully loosened.

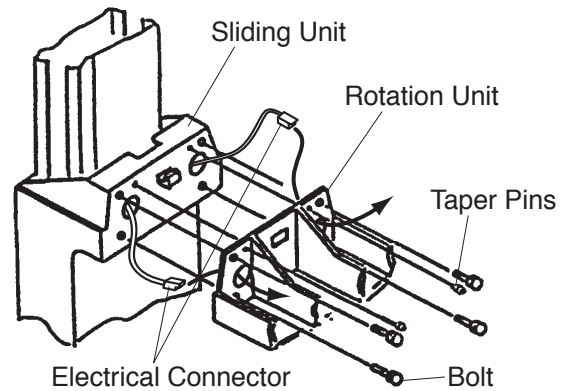

4) Take the carriage holders off the rotation unit assembly.

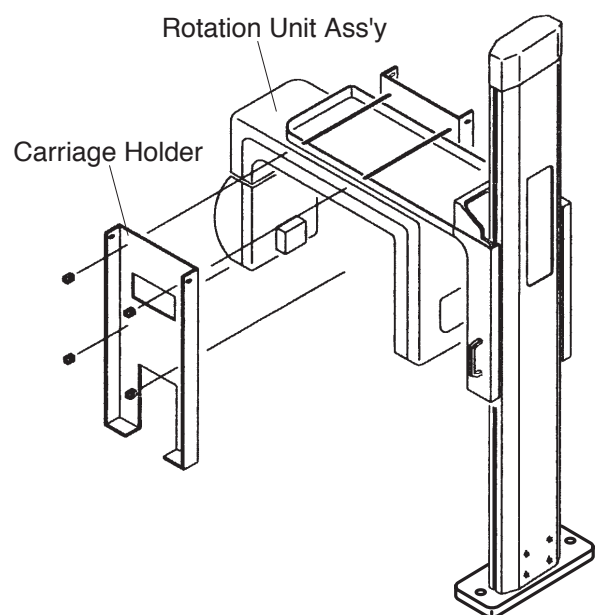

[4] CHINREST ASSEMBLY

- 1) Connect cables from the sliding unit with the cable in chinrest assembly by connectors.
- 2) While pulling the wires through front lower slot, attach chinrest ass'y to the sliding unit. Insert the wires into the slot.

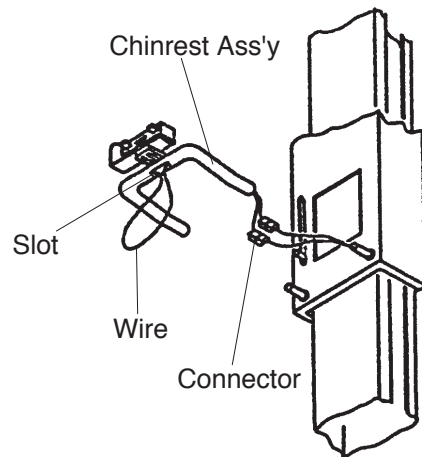

- 3) Install the chinrest in place.

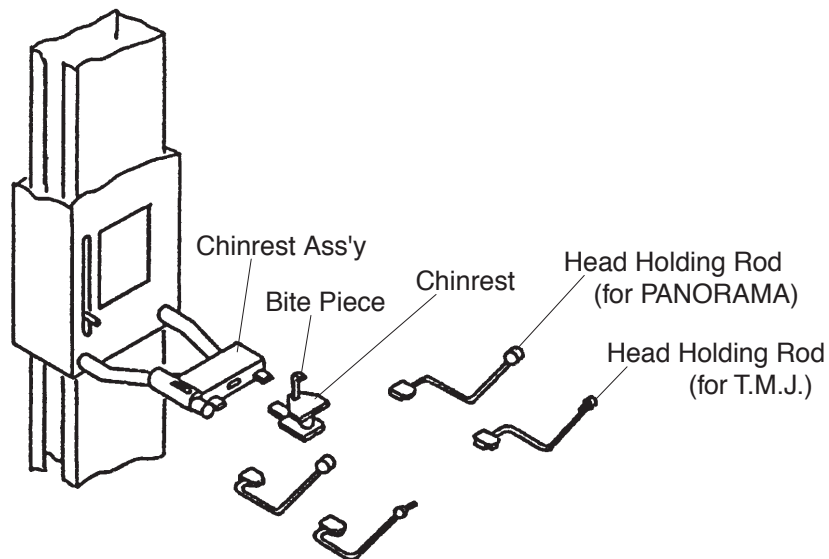

[5] CONNECTION OF WIRES

- 1) Electromagnetic lock
Place the top cover of column, then connect cable to the connector at top rear of column.
- 2) In rotation unit
Cables from sliding unit must be connected as follows;
 - (a) Connectors "CN16", "CN17", "CN24" and "CNX2" should be connected to corresponding terminals on CN Board B.
 - (b) Connector "CNL", "CNB", "CNb1" and "CNb2" are to be connected to the connectors of same I.D..

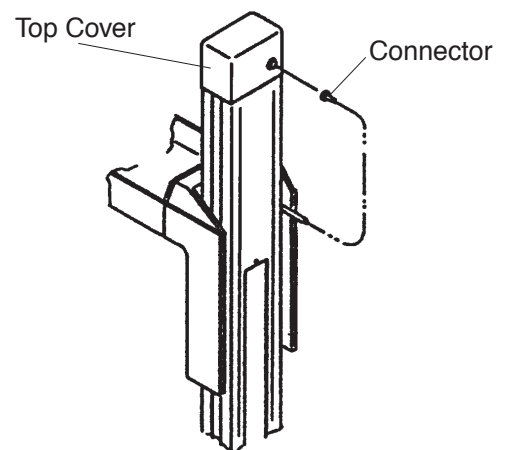

[6] CEPHALO ARM/CEPHALOSTAT ASSEMBLY

1) Cephalo arm

- (a) Attach the cephalo arm to the side of sliding unit with three screws [Do not fully Tighten].
- (b) Insert two taper pins (w/nut).
- (c) Tighten three screws firmly.
- (d) Connect cables by connectors CNb1.

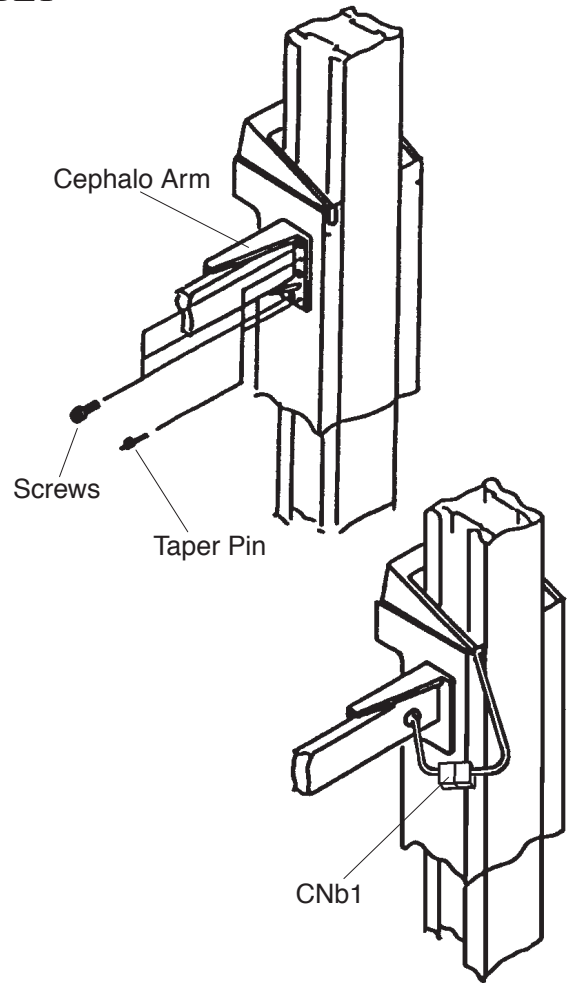

2) Cephalostat assembly

- (a) Insert two supporting rods of cephalostat into the holes of cephalo arm from underneath as far as they go, then fix them with four set screws.
- (b) Attach cassette holder with two screws.

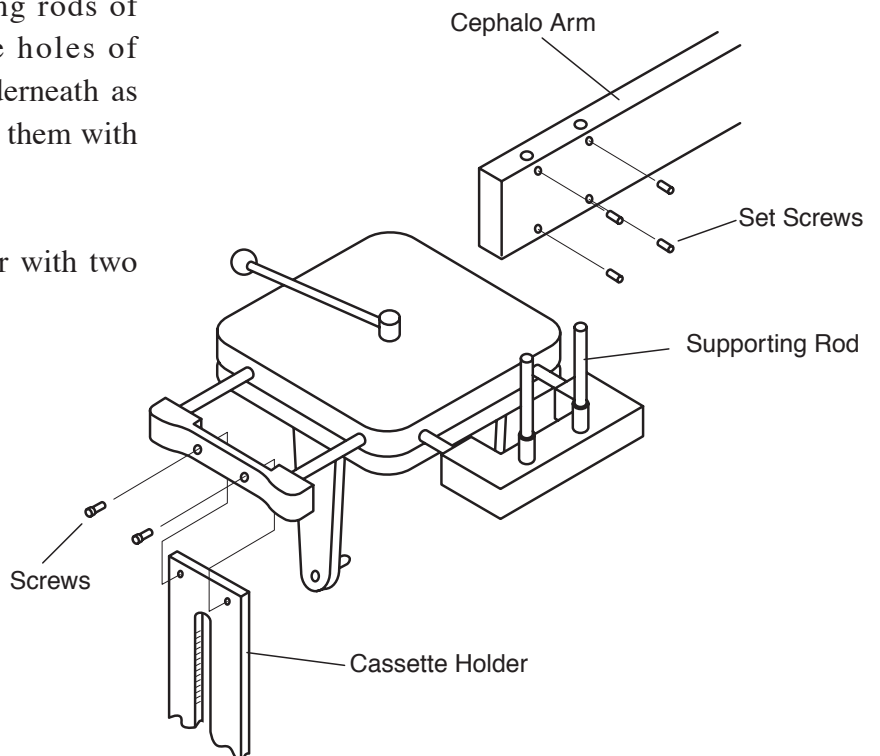

SECTION FOUR : POST-INSTALLATION CALIBRATION

[1] LINE VOLTAGE AND LINE VOLTAGE REGULATION

1. Make sure the main power switch is OFF.
Remove the top cover of the driving unit.
2. Select a range in excess of 150 VAC of multimeter. Connect probes of the meter to the terminal L1 and L2 of the connector marked CN L on the CN BOARD C. (See figure right)
3. Set switch marked "TEST" of the Dip SW3, which is located on CPU BOARD, to ON position.
4. Turn ON the main power switch.
5. Select 90 kVp and depress the ready switch on the control panel.
6. Record the no-load line voltage (VN), indicated by the multimeter before exposure, into line (1) below.
7. Make an exposure and record the loaded line voltage (VL) indicated by the multimeter during exposure into the line (2) below.
8. Calculate line voltage regulation (R) in % by substituting VN and VL values in the formula below. [Insert in item (3) below.]

$$R = (VN - VL) \div VL \times 100$$

NOTE: LINE REGULATION MUST NOT EXCEED 3%. IF IT IS GREATER THAN 3%, THE SIZE OF POWER SUPPLY WIRES MUST BE INCREASED. REFER TO THE POWER SUPPLY REQUIREMENTS OUTLINED ON PAGE 7 TO DETERMINE THE CORRECT WIRE SIZE.

9. Set the switch marked "TEST" of the Dip SW3 to OFF position.
10. Put the driving unit cover back on.

[INSERT VALUE BELOW]

① No-load line voltage VN [VAC] = _____ (VAC)

② Loaded line voltage VL [VAC] = _____ (VAC)

③ Calculation of line voltage regulation : $R = (VN - VL) \div VL \times 100$

$$R = \frac{VN^{①}(\quad) - VL^{②}(\quad)}{VL^{②}(\quad)} \times 100 = \quad \%$$

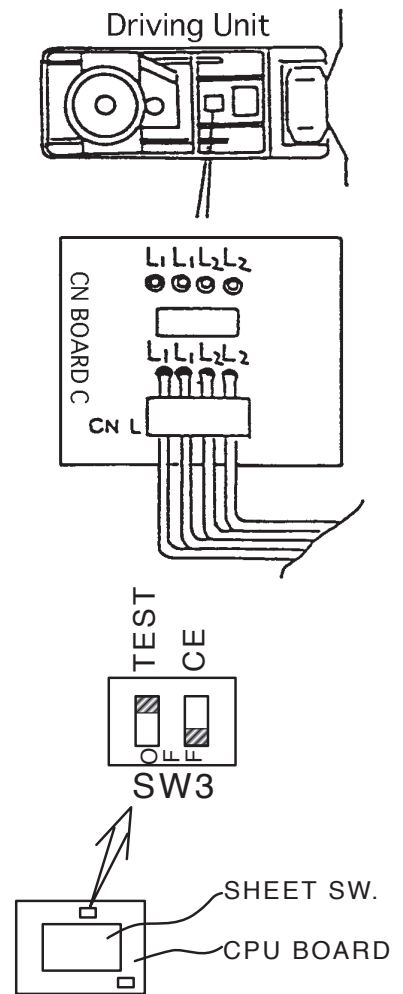

[2] TUBE CURRENT

1. Make sure the main power switch is OFF.
2. Select a range in excess of 20 mA DC of multimeter. Connect probes of the meter to the check points CP+ and CP- of the CPU BOARD. Set JP1 switch to the OFF position.
3. Set the switch marked "TEST" of the Dip SW3, which is located on the CPU BOARD, to ON position.
4. Turn ON the main power switch.
5. Select 75 kVp and depress the ready switch on the control panel.
6. Point the x-ray head away from all personnel.
7. Make an exposure and record a mA indication on the multimeter during exposure.
NOTE: ALLOW 3 MINUTES COOLING TIME BETWEEN EXPOSURES.
8. Select 90 kVp and make an exposure and record the reading again.
9. Select 60 kVp and make an exposure and record the reading again.
10. Make sure all readings are within the range of 10 ± 1 mA DC.
11. Set the switch marked "TEST" of the Dip SW3 to OFF position, and set JP1 to ON position.
12. Put the cover for the controller back on.

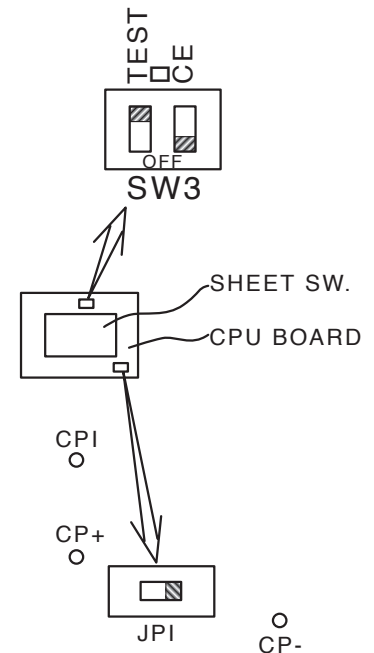

[3] EXPOSURE TIME

1. Make sure the main power switch is OFF. Remove the top cover of the rotation unit.
2. Connect probes of the voltage impulse counter to the check point CP T1 and CP T2 of the POWER BOARD.
3. Turn ON the main power switch.
4. Depress the reset switch.
5. Select 75 kVp and depress the ready switch on control panel.
6. Make an exposure at panoramic mode, allowing the rotation unit to cycle fully to auto stop position.
7. Make sure the registered reading is within the range of 720 ± 36 impulses.
NOTE: ALLOW 3 MINUTES COOLING TIME BETWEEN EXPOSURES.
8. Repeat the procedures 4 thru 6 at TMJ mode.
9. Make sure the registered reading is within the range of 900 ± 45 impulses.
NOTE: ALLOW 3.75 MINUTES COOLING TIME BEFORE NEXT STEP.
10. Depress the Cephalometric mode switch, select 75 kVp and make exposures at 0.3sec., 0.5sec., 0.8sec., and 3.2sec..
11. Read the reading of the voltage impulse counter and make sure the reading are within the

Settings	0.3	0.5	0.8	3.2	unit:second
Limit	18 ± 2	30 ± 2	48 ± 3	192 ± 5	unit:pulse

following limits.

12. Put the top cover of the rotation unit back on.

[4] X-RAY FIELD SIZE AND ALIGNMENT

A. Panoramic mode

1. Set the panoramic cassette onto the panoramic cassette holder.

NOTE: T-MAT G FILM SHOULD BE LOADED.

2. Turn the Main power switch ON and depress the Reset switch.

3. Select 60 kVp and depress the cephalo switch on the control panel to select the exposure time of 0.3 Sec.

4. Depress the ready switch and make an exposure of 0.3 sec.

5. Develop the film.

6. Make sure that the radiation field dose not extend beyond any edge of the slit of the shield plate and the dimension is not greater than 15 x 150 mm.

B. Cephalometric mode

7. Set the cephalometric cassette onto the cephalo cassette holder.

NOTE: T-MAT G FILM SHOULD BE LOADED.

8. Engage the Rotation lock to secure the Rotation unit in cephalometric position.

9. Depress the ready switch and make an exposure of 0.3 sec. at 60 kVp.

10. Develop the film.

11. Make sure that the radiation field dose not extend beyond any edge of the film.

APPENDIX ONE : CERTIFICATION

FOR FDA USE ONLY	DEPARTMENT OF HEALTH AND HUMAN SERVICES PUBLIC HEALTH SERVICE FOOD AND DRUG ADMINISTRATION	From Approved: OMB No. 0910-0213 Expiration Date: December 31, 1992 See reverse for OMB statement.
	REPORT OF ASSEMBLY OF A DIAGNOSTIC X-RAY SYSTEM	D XXXXXX

1. EQUIPMENT LOCATION		2. ASSEMBLER INFORMATION	
a. NAME OF HOSPITAL, DOCTOR OR OFFICE WHERE INSTALLED		a. COMPANY NAME ✓	
b. STREET ADDRESS		b. STREET ADDRESS ✓	
c. CITY	d. STATE	c. CITY ✓	d. STATE ✓
e. ZIP CODE	f. TELEPHONE NUMBER	e. ZIP CODE ✓	f. TELEPHONE NUMBER ✓

3. GENERAL INFORMATION

a. THIS REPORT IS FOR ASSEMBLY OF CERTIFIED COMPONENTS WHICH ARE (Check appropriate box(es))

<input checked="" type="checkbox"/> NEW ASSEMBLY - FULLY CERTIFIED SYSTEM	<input type="checkbox"/> REPLACEMENT COMPONENTS IN AN EXISTING SYSTEM
<input type="checkbox"/> REASSEMBLY - FULLY CERTIFIED SYSTEM	<input type="checkbox"/> AN ADDITION TO AN EXISTING SYSTEM
<input type="checkbox"/> REASSEMBLY - MIXED SYSTEM (Both certified and uncertified components)	

b. INTENDED USE(S) (Check applicable box(es))

<input type="checkbox"/> GENERAL PURPOSE RADIOGRAPHY	<input type="checkbox"/> UROLOGY	<input type="checkbox"/> CT HEAD SCANNER	<input checked="" type="checkbox"/> DENTAL PANORAMIC
<input type="checkbox"/> GENERAL PURPOSE FLUOROSCOPY	<input type="checkbox"/> MAMMOGRAPHY	<input type="checkbox"/> CT WHOLE BODY SCANNER	<input type="checkbox"/> RADIATION THERAPY SIMULATOR
<input type="checkbox"/> TOMOGRAPHY (Other than CT)	<input type="checkbox"/> CHEST	<input type="checkbox"/> HEAD - NECK (Medical)	<input type="checkbox"/> C - ARM FLUOROSCOPIC
<input type="checkbox"/> ANGIOGRAPY	<input type="checkbox"/> CHIROPRACTIC	<input checked="" type="checkbox"/> DENTAL - INTRAORAL	<input type="checkbox"/> DIGITAL
		<input checked="" type="checkbox"/> DENTAL - CEPHALOMETRIC	<input type="checkbox"/> OTHER (Specify in comments)

c. THE X-RAY SYSTEM IS (Check one)

STATIONARY MOBILE

d. THE MASTER CONTROL IS IN ROOM

Location of Control Box

e. DATE OF ASSEMBLY

✓	✓	✓
(mo.)	(day)	(yr.)

4. COMPONENT INFORMATION (If additional space is needed for this section use another form, replacing the pre-printed Number and complete items 1,4, and 5 only)

a. THE MASTER CONTROL IS <input checked="" type="checkbox"/> A NEW INSTALLATION <input type="checkbox"/> EXISTING (Certified) <input type="checkbox"/> EXISTING (Non-certified)	b. CONTROL MANUFACTURER Belmont Equipment Corp.	b. CONTROL SERIAL NUMBER ✓
	c. CONTROL MODEL NUMBER X-Caliber-C	c. SYSTEM MODEL NAME (CT Systems Only)

Complete the following information for the certified components listed below which you installed. For beam limited device, tables and CT gantries the manufacturer and Model number in the indicated spaces. For other certified components, enter in the appropriate block how many of each you installed in this system.

f. SELECTED COMPONENTS				OTHER CERTIFIED COMPONENTS	
	MANUFACTURER	MODEL NUMBER	DATE MANUFACTURED	f. (Enter number of each installed in appropriate block)	
BEAM LIMITING DEVICE	Belmont Equipment	X-Caliber CM-B		<input checked="" type="checkbox"/> 1 X-RAY CONTROL	<input type="checkbox"/> CRADLE
	MANUFACTURER	MODEL NUMBER	DATE MANUFACTURED	<input type="checkbox"/> HIGH VOLTAGE GENERATOR	<input type="checkbox"/> FILM CHANGER
TABLES	MANUFACTURER	MODEL NUMBER	DATE MANUFACTURED	<input type="checkbox"/> VERTICAL CASSETTE HOLDER	<input type="checkbox"/> IMAGE INTENSIFIER
	MANUFACTURER	MODEL NUMBER	DATE MANUFACTURED	<input checked="" type="checkbox"/> 1 TUBE HOUSING ASSEMBLY (Medical)	<input type="checkbox"/> SPOT FILM DEVICE
CT GANTRY	MANUFACTURER	MODEL NUMBER	DATE MANUFACTURED	<input type="checkbox"/> DENTAL TUBE HEAD	<input type="checkbox"/> OTHER (Specify)

5. ASSEMBLER CERTIFICATION

I affirm that all certified components assembled or installed by me for which this report is being made, were adjusted and tested by me according to the instructions provided by the manufacturer(s), were of the type required by the diagnostic x-ray performance standard (21 CFR Part 1020), were not modified to adversely affect performance, and were installed in accordance with provisions of 21 CFR Part 1020. I also affirm that all instruction manuals and other information required by 21 CFR Part 1020 for this assembly have been furnished to the purchaser and within 15 days from the date of assembly, each copy of this report will be distributed as indicated at the bottom of each copy.

a. PRINTED NAME ✓	b. SIGNATURE ✓	c. DATE ✓
d. COMMENTS		

APPENDIX TWO : LAYOUT & FUNCTION OF CONTROLS

(1) MAIN POWER “ON” AND “OFF” SWITCHES

Depressing POWER “ON” switch will turn the main power ON.

NOTE: Indicators show standard conditions of 75 kVp and 12 Sec. when the main power is turned ON.

(2) kVp “UP” & “DOWN” SWITCHES

Tube potential can be adjusted by depressing “UP” or “DN (Down)” switch between 60 and 90 kVp by 5 kVp increment or decrement.

(3) RESET SWITCH

Depressing this switch moves x-ray head assembly and cassette holder to the starting position for panoramic or TMJ radiography.

NOTE: The switch located on the rotation arm has the same function. Refer to page 4, I.D. No.11.

(4) READY SWITCH

Depress this switch after all the radiographing conditions are set, film cassette is mounted and patient is properly positioned.

An exposure can be made after the indicator lamp flashes three times and stays lit.

READY switch should be activated again after first exposure of TMJ radiography.

NOTE 1: READY switch turns ON only when the x-ray head assembly and the cassette holder are at starting position.

NOTE 2: Ready status will be cancelled unless an exposure starts within 15 seconds. (If you are making an exposure after 15 seconds, depress READY switch again.)

NOTE 3: READY switch will not function for 15 seconds after the main power switch is turned ON.

(5) TMJ SWITCH

TMJ radiography can be made by depressing this switch.

(6) INDICATOR SWITCH

By depressing INDICATOR switch, following three beam lines are available for 50 seconds.

- 1) Median Line
- 2) Frankfort Line
- 3) Focal Trough Line

(7) EXPOSURE INDICATOR

This lamp will remain illuminated while x-ray is being generated.

(8) CEPHALOMETRIC SWITCH (MODEL X-CALIBER CM ONLY)

By depressing this switch, cephalometric mode can be selected.

(9) SEC. “UP” & “DN” SWITCHES

Exposure time can be adjusted by depressing “UP” or “DN” switch.

LAYOUT OF CONTROLS

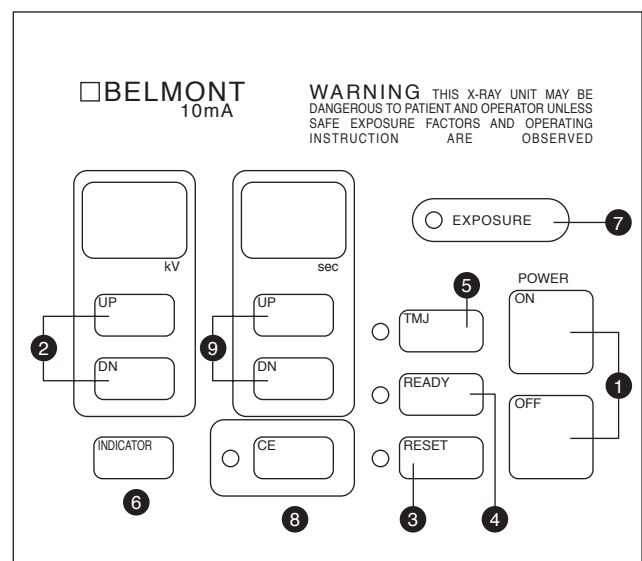

APPENDIX THREE : CIRCUIT DIAGRAM

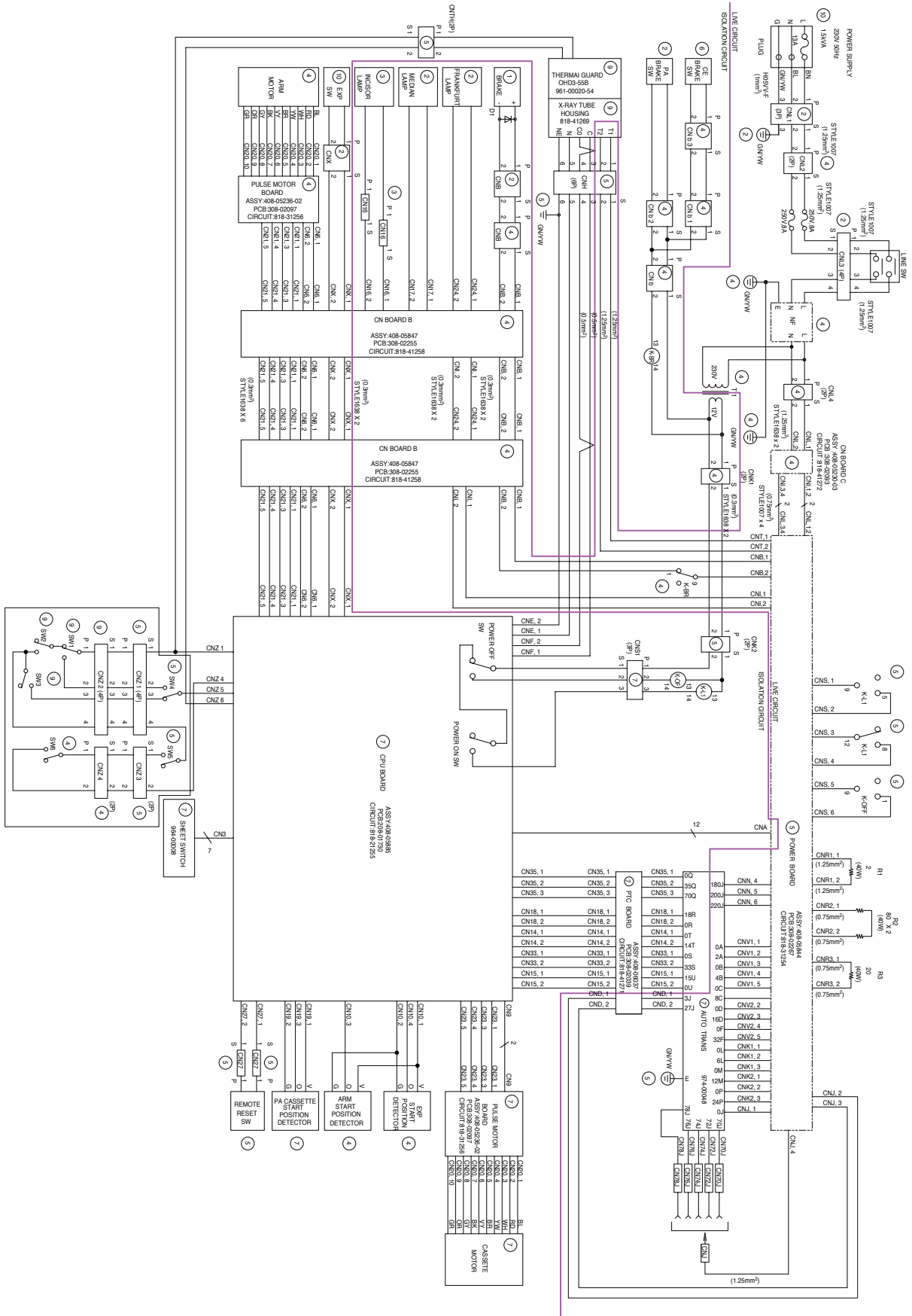

APPENDIX FOUR : PARTS LIST

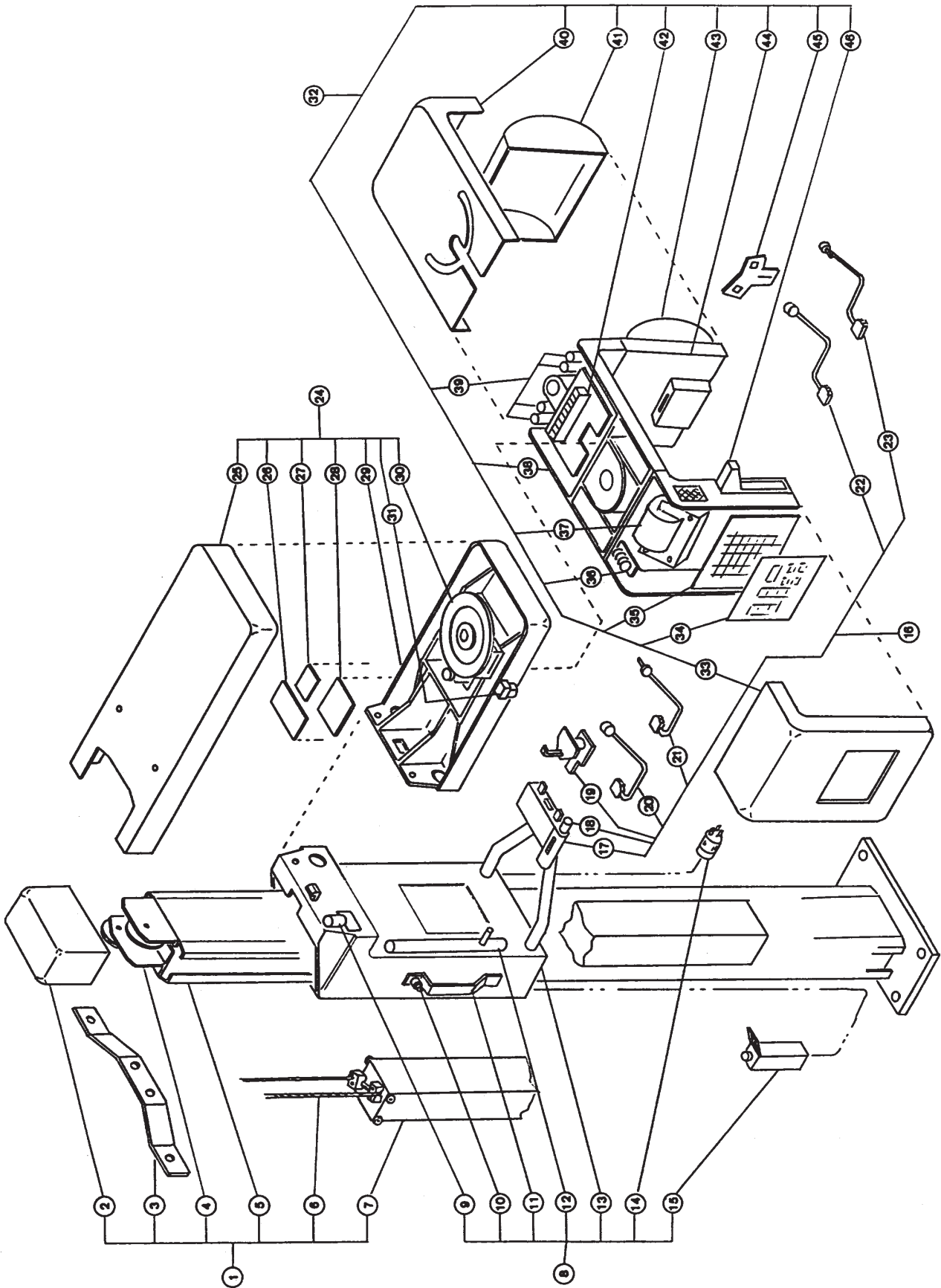

X-Caliber Major Components and Parts

ID No.	Description
1	Column Assembly
2	Top Cover
3	Wall Bracket
4	Pulley Assembly
5	Column
6	Wire Cable
7	Counter-weight Frame
8	Sliding Unit Assembly
9	Position Indicator (Median Line)
10	Electro-magnetic Lock Switch
11	Sliding Grip
12	Position Indicator (Frankfort Line)
13	Sliding Unit Body
14	Power Supply Cable
15	Exposure Switch
16	Chinrest Assembly
17	Chinrest Frame
18	Position Indicator (Focal Trough Line)
19	Chinrest (w/Bite Fork)
20	Head Holding Rod (Left, for Panorama)
21	Head Holding Rod (Left, for TMJ)
22	Head Holding Rod (Right, for Panorama)
23	Head Holding Rod (Right, for TMJ)
24	Driving Unit Assembly
25	Driving Unit Cover
26	CN Board "A"
27	CN Board "C"
28	Pulse Motor Board
29	Driving Unit Frame
30	Motor Unit Assembly
31	Rotation Lock Assembly (for Cephalo)
32	Rotation Unit Assembly
33	Cover for Controller
34	Sheet Switch
35	CUP Board
36	PTC Board
37	Auto-Transformer
38	Rotation Unit Frame
39	Resisters
40	Rotation Unit Cover
41	X-Ray Head Cover
42	Power Board
43	X-Ray Head Assembly
44	X-Ray Head Housing
45	Beam Limiting Device (for Cephalo)
46	Cassette Holder

X-CALIBER CM

CEPHALOMETRIC DEVICE

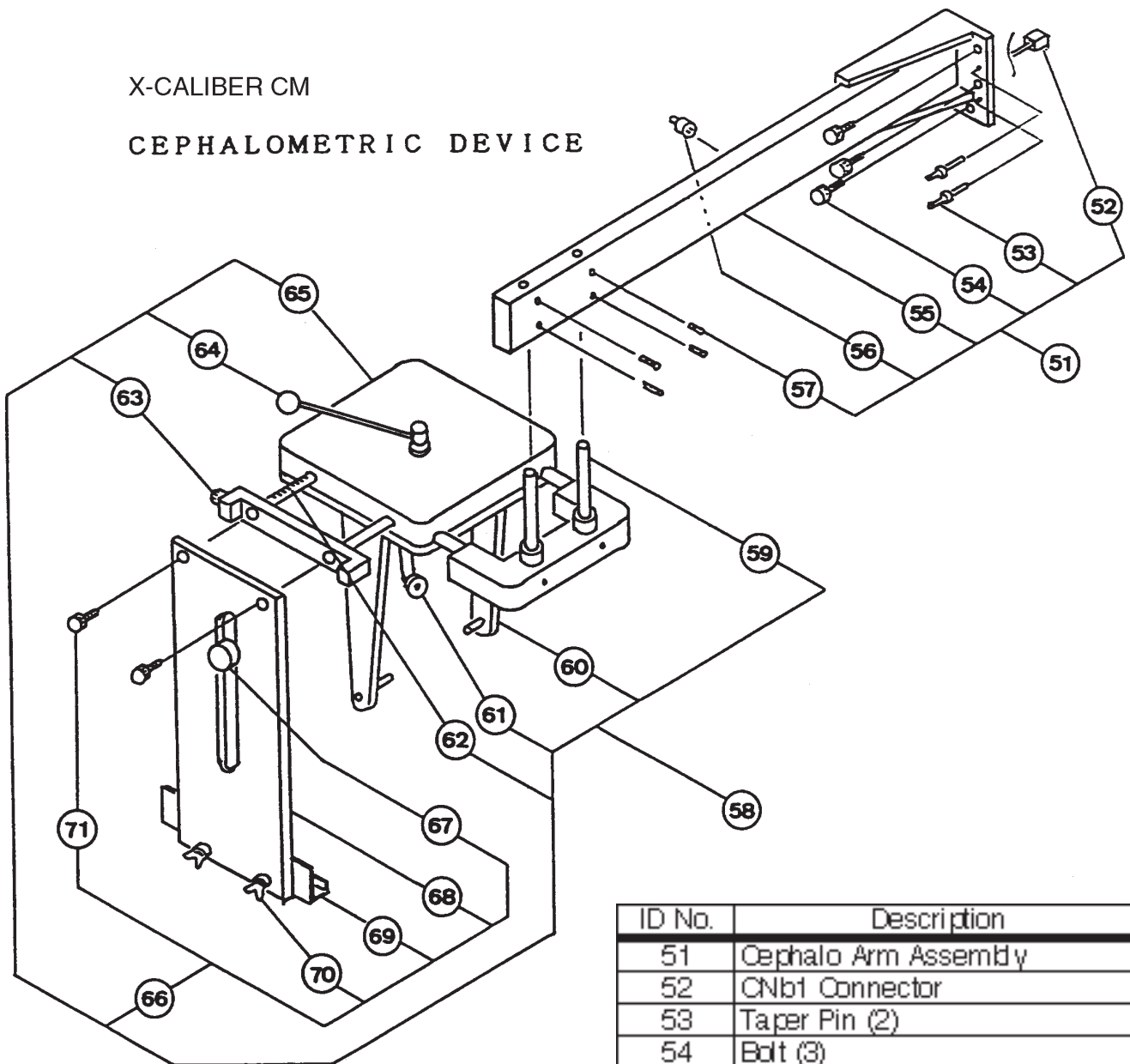

ID No.	Description
51	Cephalo Arm Assembly
52	CNb1 Connector
53	Taper Pin (2)
54	Bolt (3)
55	Cephalo Arm
56	Electro-magnetic Switch
57	Set Screw (4)
58	Cephalostat Assembly
59	Supporting Rod (2)
60	Ear Holding Rod (2)
61	Forehead Rest
62	Cassette Position Scale
63	Cassette Position Lock
64	Ear Holding Rod Adjuster
65	Cephalostat Top Cover
66	Cassette Holder Assembly
67	Cassette Holder Knob
68	Cassette Holder Plate
69	Cassette Holder Base
70	Wing Screw (2)
71	Screw (2)

NOTE

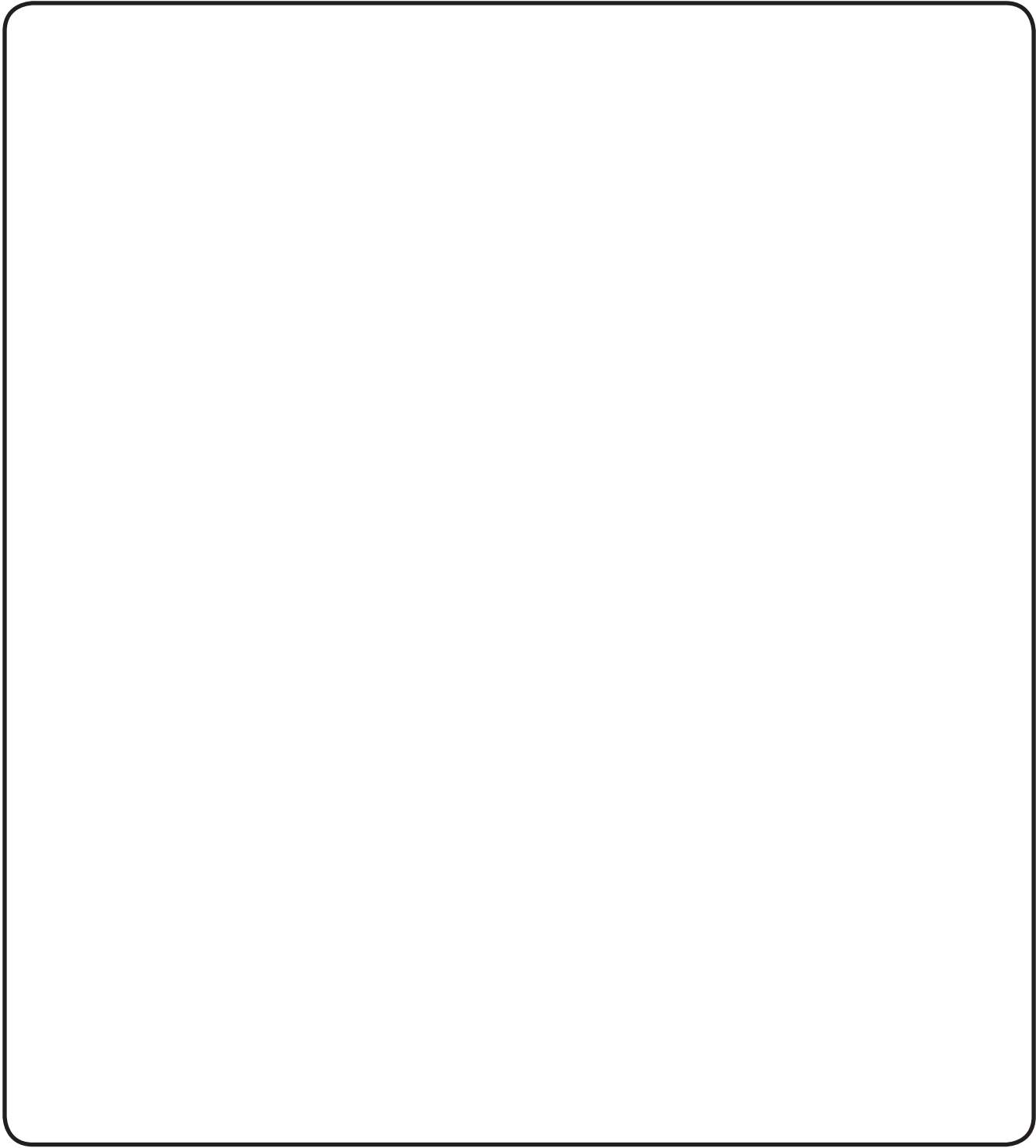

BELMONT EQUIPMENT CORP.

101 Belmont Drive Somerset, New Jersey 08873 U.S.A.

TEL.:(732) 469-5000 / (800) 223-1192 Fax.:(732)526-6322 / (800) 280-7504

TAKARA CO, CANADA LTD.

2076 S. Sheridan Way, Mississauga, Ont., L5J2M4, Can.

TEL.:(905) 822-2755 Fax.:(905)822-6203

Printed in Japan 0603 MA