

# PHOT-X II

**MODEL 303**

***DENTAL X-RAY***

## **INSTALLATION INSTRUCTIONS (for USA & Canada)**

**⚠ WARNING**

**This X-ray equipment may be dangerous to patients and operators unless safe exposure factors and operating instructions are observed.**

** Belmont®**

0501 (REV.0)

# INDEX

	PAGE
SECTION 1 : TECHNICAL DATA	
[1] ELECTRICAL AND RADIATION DATA -----	2
[2] PHYSICAL DIMENSIONS -----	3
[3] TUBE HEAD THERMAL CHARACTERISTICS -----	4
SECTION 2 : PRE-INSTALLATION INSTRUCTIONS	
[1] SUPPORT REQUIREMENTS -----	5
[2] ELECTRICAL REQUIREMENTS -----	5
[3] LOCATION OF COMPONENTS -----	6
SECTION 3 : INSTALLATION INSTRUCTIONS	
[1] INSTALLATION REQUIREMENTS -----	7
[2] UNPACKING -----	7
[3] MAIN CONTROLLER AND ARM INSTALLATION -----	8
[4] HEAD ASSEMBLY INSTALLATION -----	12
[5] SUB CONTROLLER INSTALLATION -----	14
[6] HAND EXPOSURE SWITCH (OPTION) -----	15
SECTION 4 : POST INSTALLATION INSPECTION	
[1] ARM ASSEMBLY -----	16
[2] BALANCE ARM TENSION ADJUSTMENT -----	16
[3] HEAD POSITIONING -----	16
SECTION 5 : CONTROL IDENTIFICATION AND OPERATION	
[1] MAJOR COMPONENTS AND CONTROL IDENTIFICATION -----	17
[2] FUNCTION OF CONTROLS -----	18
[3] OPERATING PROCEDURES -----	20
[4] OPTIONAL HAND EXPOSURE SWITCH -----	20
[5] ERROR CODES -----	21
[6] MAINTENANCE -----	22
SECTION 6 : POST INSTALLATION CONFIRMATION	
[1] CONFIRMATION OF POWER SUPPLY VOLTAGE -----	23
[2] CONFIRMATION OF TUBE POTENTIAL AND TUBE CURRENT -----	23
[3] CONFIRMATION OF TUBE CURRENT -----	23
[4] CONFIRMATION OF EXPOSURE WARNING LAMP & BUZZER -----	24
[5] CONFIRMATION OF LINE VOLTAGE REGULATION -----	24
SECTION 7 : INITIAL SETTING	
[1] SPEED SETTING FOR FILM AND DIGITAL IMAGING -----	25
[2] PRIORITY OF SELECTIONS -----	26
[3] ELECTRONIC CHIME ON/OFF -----	27
APPENDIX 1 : CIRCUIT DIAGRAM -----	27
APPENDIX 2 : PARTS IDENTIFICATION	
[1] ARM AND HEAD ASSEMBLY -----	28
[2] CONTROLLER ASSEMBLY -----	29
APPENDIX 3 : CERTIFICATION -----	30

## CAUTION

This manual provides information and instructions for the installation, assembly calibration and certification procedures for **BELMONT PHOT-X II MODEL 303** dental x-ray. The instructions contained in this book should be thoroughly read and understood by dealer service personal before attempting to install the X-ray unit. After installation is completed, owners should file this manual and refer back to it to schedule periodic maintenance.

## SECTION 1 : TECHNICAL DATA

### [ 1 ] ELECTRICAL AND RADIATION DATA

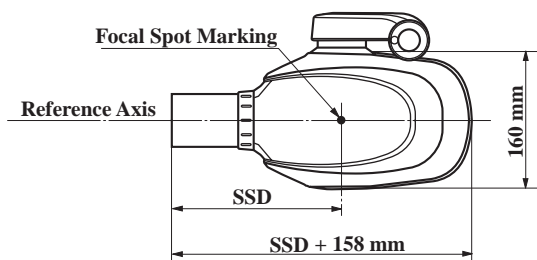
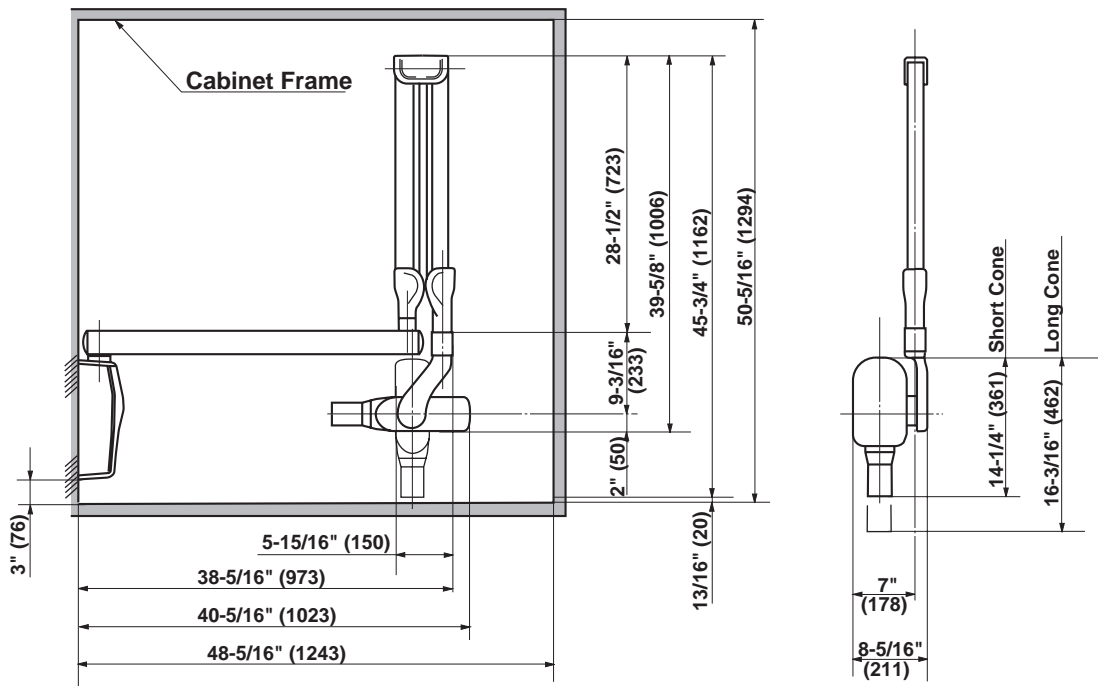
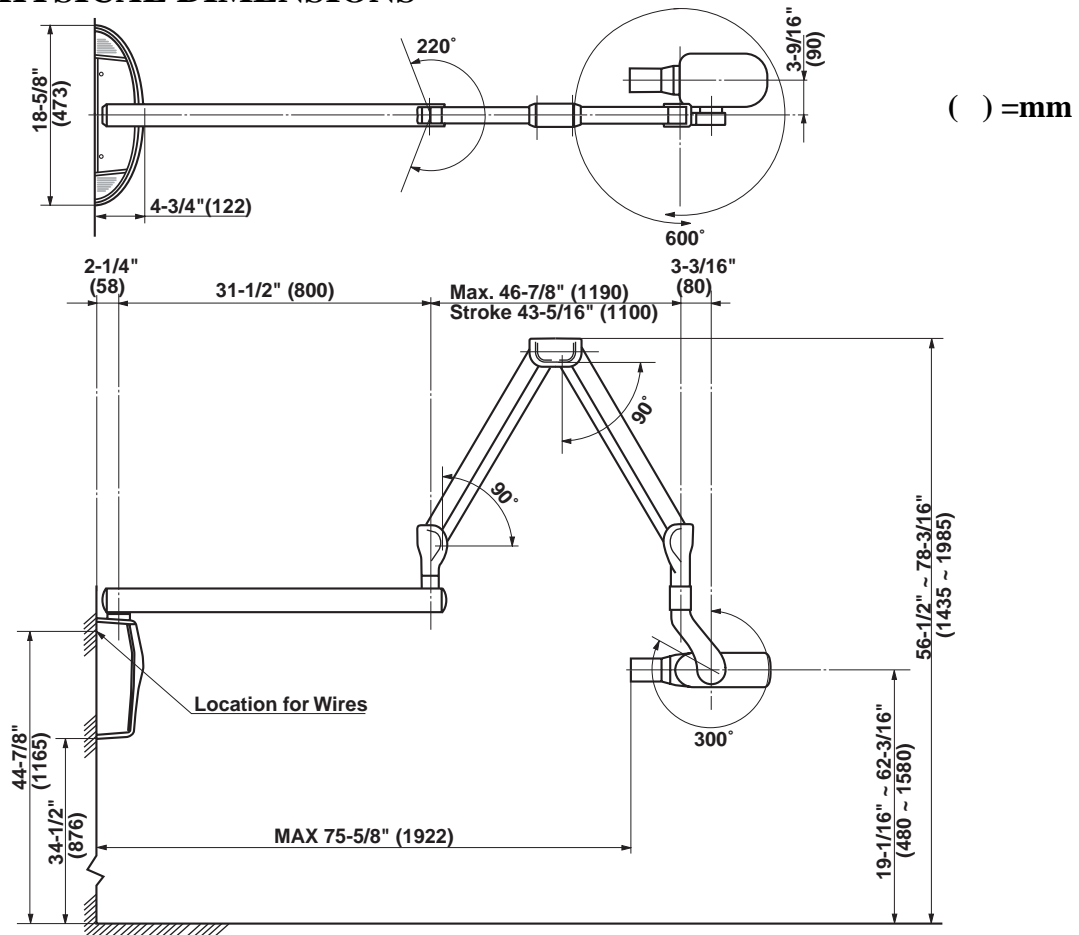
1. X-ray tube ----- Toshiba D-0711 (Stationary Anode)
  - a. Focal spot ----- 0.7 mm
  - b. Target Material ----- Tungsten
  - c. Target angle ----- 16°
  - d. Maximum anode heat content ----- 7kJ (10kHU)
2. Maximum x-ray tube assembly heat content ----- 120kJ (170kHU)
3. Rated peak tube potential ----- 60 kV / 70 kV selectable
4. Rated tube current ----- 4 mA / 7 mA selectable
5. Maximum rated peak tube potential ----- 70 kV
6. Rated line voltage ----- 120 VAC, 60Hz, Single phase, 1.3 kVA
7. Line voltage range ----- 108 VAC ~ 132 VAC
8. Range of line voltage regulation ----- 2 ~ 5 %
9. Rated line current ----- 10.8 A at 70 kV, 7 mA
10. Maximum line current ----- 12 A at 70 kV, 7 mA
11. Exposure time ----- 0.01 ~ 3.2 sec.
12. Inherent filtration ----- 1.7 mm Al Equivalent
13. Added filtration ----- 0.3 mm Al
14. Minimum filtration permanently in useful beam ----- 2.0 mm Al Equivalent at 70 kV
15. Nominal roentgen output

	60 kV	70 kV
a. Distal end of regular cone -----	4 mA 7 mA	4 mA 7mA
b. Distal end of long cone -----	5.4 9.4	7.1 12.4 mGy/sec. ± 40%
	2.4 4.2	3.1 5.5 mGy/sec. ± 40%

(Data obtained by direct measurement in the useful beam)
16. Nominal electrical output of H.V. generator ----- 0.49 kW at 70 kV, 7 mA
17. Cone

	Source to skin distance	Field size
a. Regular cone -----	8 inches (203 mm)	58 mm dia., circular
b. Long cone (option) -----	12 inches (305 mm)	58 mm dia., circular
c. Rectangular cone (option) -----	8 inches (203 mm)	36 x 47 mm, rectangular
18. Maximum symmetrical radiation field ----- 60 mm dia. at distal end of cone
19. Leaking technique factor ----- 70 kV / 0.14 mA  
(0.14 mA is maximum rated continuous current for 7 mA with a duty cycle 1 : 50)
20. Duty cycle ----- 1 : 50 (0.5 sec. exposure with 25 sec. interval)
21. Maximum deviation of tube potential, tube current and exposure time
  - a. Below 0.1 sec. setting ----- ±10 kV, ±2 mA, ±5 msec.
  - b. 0.1 sec. setting & up ----- ±5 kV, ±1 mA, ±10 msec.
22. Measurement base of technique factors
  - a. peak tube potential ----- Average of peak tube potentials during one exposure
  - b. tube current ----- Average of tube current during one exposure
  - c. exposure time ----- Time period during x-ray is emitted
23. Half value layer ----- 1.5 mm Al over
24. Source to the base of cone distance ----- 94 mm
25. Environmental condition for storage ----- -20 ~ 70°C, 10 ~ 100%, 500 ~ 1060hPa

## [ 2 ] PHYSICAL DIMENSIONS



SSD (Source to Skin Distance) :

- a. Regular cone-----8 inches (203 mm)
- b. Long cone-----12 inches (305mm)
- c. Rectangular cone-----8 inches (203 mm)

**Fig.1-1** Dimensions

# [ 3 ] TUBE HEAD THERMAL CHARACTERISTICS

## A. Interval between each exposure

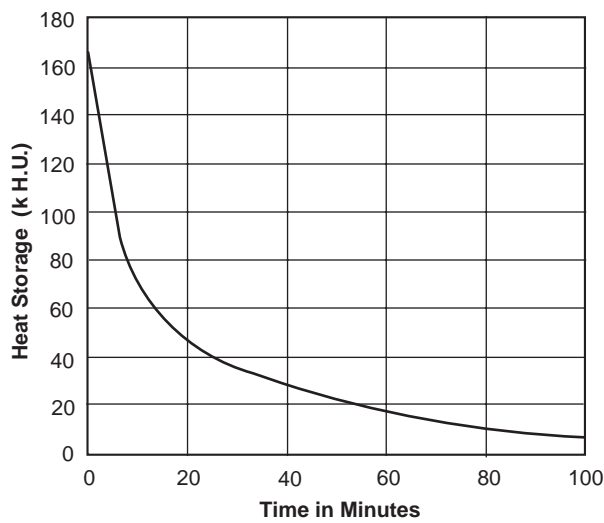
The temperature inside of the tube head rises when an exposure is made. The value of the heat generated is measured in Heat Units (HU), which is the product of tube potential, tube current and exposure time. Excessive heat will accumulate inside of the tube head if the x-ray is used without a proper cool down interval between each exposure. The excessive heat may damage the x-ray tube, high voltage generator or both.

## B. Duty cycle

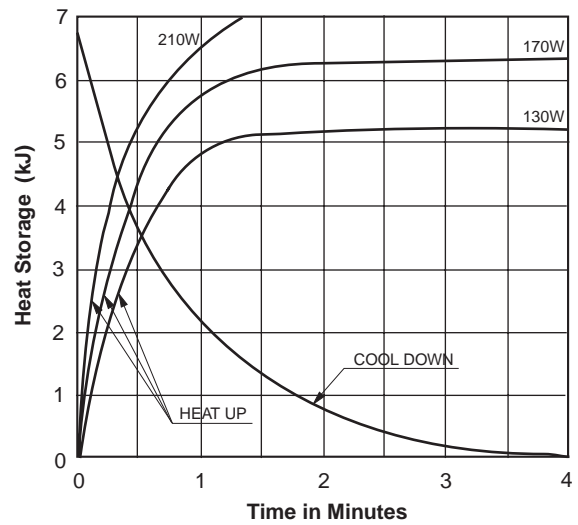
A cool down interval of 50 seconds or more must be allowed between each 1 second exposure. (a 25 second cool down must be allowed between each 0.5 second exposure.) This will avoid the accumulation of excess heat and prolong the tube head life.

## C. Tube head cooling curve

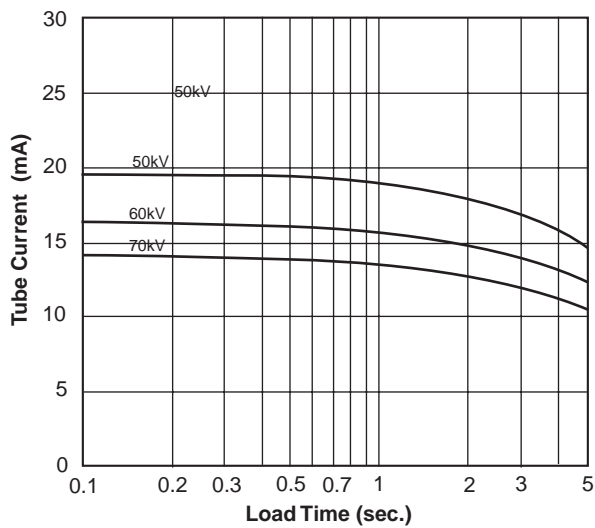
### 1. Tube Hosung cooling curve



### 2. Anode thermal characteristics



### 3. Maximum rating chart



## SECTION 2 : PRE-INSTALLATION INSTRUCTIONS

### [ 1 ] SUPPORT REQUIREMENTS

#### Main Controller :

The main controller of model 303 has a wall plate designed for mounting on two 2 x 4 wood studs with 16 inches (406mm) centers. The wall and mounting hardware must be sufficient to withstand a **100 pound (45kg) shear load and a 450 pound (205kg) with drawal force** at each of the four (ø 9 x 75mm) lag screws.

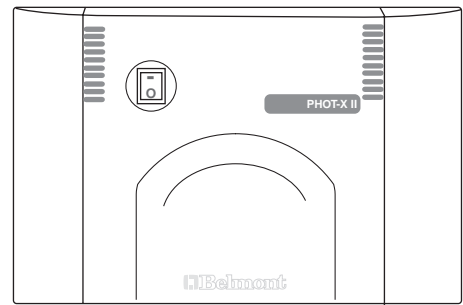


Fig.2-1 Main Controller

#### Sub Controller :

When mounting the model 303 sub controller, the wall and mounting hardware must be sufficient to withstand a **10 pound (45kg) shear load**.

### ⚠ CAUTION

**If the PHOT-X II Model 303 is to be mounted in a manner other than what is specified in this manual or if the hardware to be used is other than what is supplied, the support capability of the wall and the strength of the hardware must be checked and verified to be adequate.**

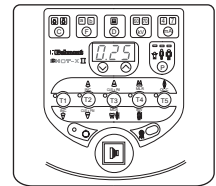


Fig.2-2 Sub Controller

### [ 2 ] ELECTRICAL REQUIREMENTS

#### Power supply :

The model 303 x-ray system will operate on a power supply of 120VAC  $\pm$  10% (108 ~ 132V AC) with a 3 wire GROUNDED circuit, separately connected to the central distribution panel with an over current protection device rated for 15 amperes. Recommended wire size is 14 AWG ; but if the wire run distance is to exceed 50 feet (15m), 12 AWG is required. For wire run distances in excess of 75 feet (23m) 10 AWG is required. Line voltage regulation must be within 2 ~ 5 % at 10.8 amps.

#### Interconnecting wiring between main controller and sub controller :

4 conductor, 20 AWG, 300V is recommended. Maximum wire run distance is 33 feet (10m).

#### Concealed wiring :

Route conduit and wires through wall and into (2) flush mounted junction boxes located (1) behind the main controller and (1) behind the sub controller. Recommended heights above the finished floor for the flush junction boxes are : 44-7/8" (1140mm) for the main controller and 51-5/8" (1310mm) for the sub controller. Wiring done in this manner should extend 12 inches (300mm) beyond the wall surface to allow sufficient wire for connections.

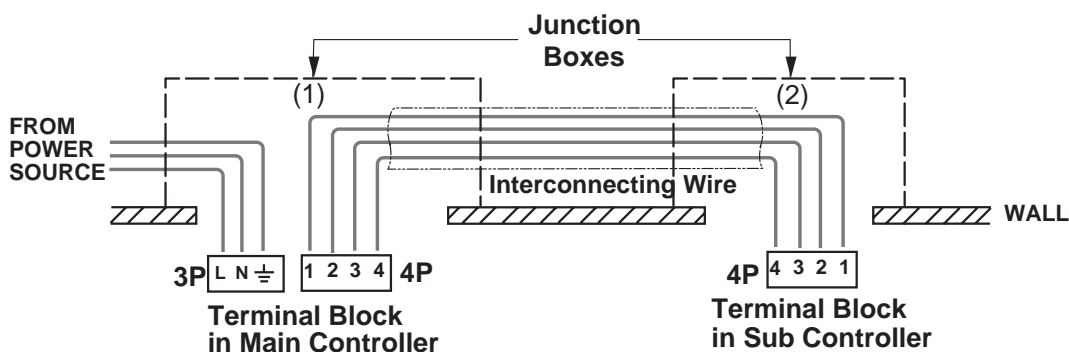


Fig.2-3 Concealed Wiring

**Note :** Follow local and national electrical code (NFPA 70) requirements during installation.

### [ 3 ] LOCATION OF COMPONENTS

#### A. Main Controller, Arm and Head Assemblies :

Using the information Provided in Fig.2-4, determine the correct location for the main controller.

#### ⚠ CAUTION

PHOTX-II Model 303 x-ray unit should be installed on the wall that prevents the horizontal arm rotate 360°.

NOTE : State and local requirements supersede guide lines indicated below.

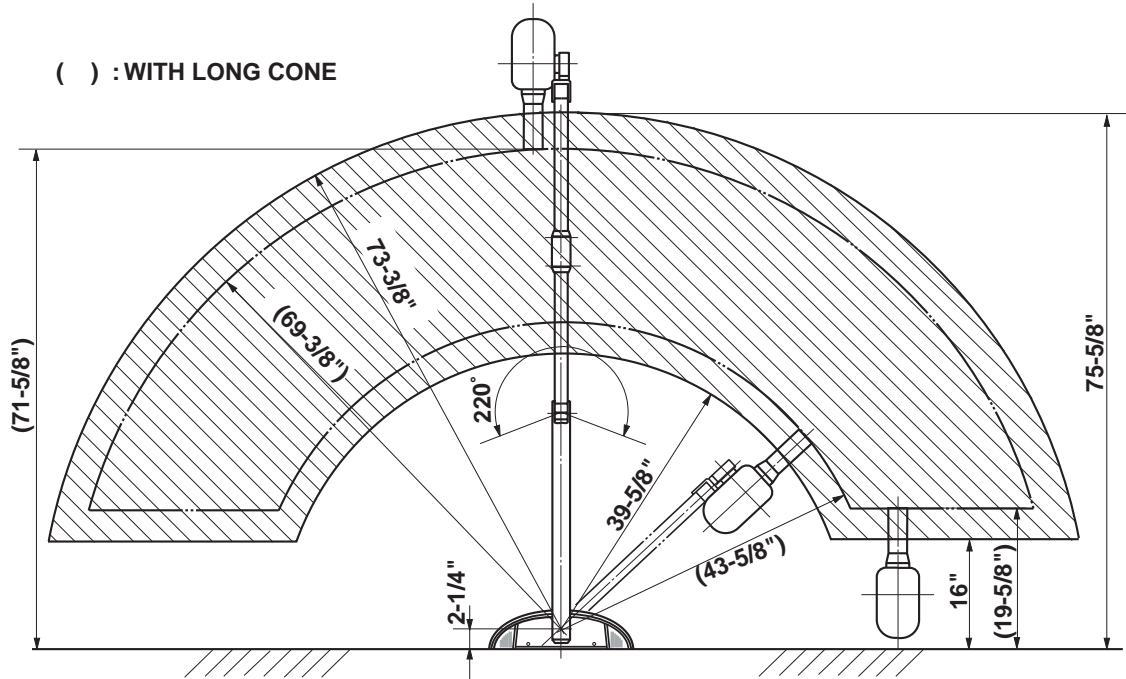


Fig.2-4 Radius of Activity for X-ray Head

#### B. Sub controller

When determining the location for the sub controller, the following radiation requirements concerning the operator's positioning must be considered.

The operator must :

1. have full view of the patient.
2. have full view of kV, mA, timer selections and exposure warning light.
3. be a minimum of 6 feet (1.8m) away from the patient.
4. be out of line of the useful beam of radiation or be positioned behind a protective device with x-ray protection equivalent of 1 mm of lead.

### SECTION 3 : INSTALLATION INSTRUCTIONS

Within the installation and confirmation procedures are inspection/test steps which the installer must perform to insure that the installation meets the manufacturer's specifications. These steps require the installer to record the necessary information onto the "ASSEMBLER'S INSTALLATION SECTION OF THE LIMITED WARRANTY REPORT FORM" supplied, which **MUST** be returned to BELMONT along with the warranty card.

#### [ 1 ] INSTALLATION REQUIREMENTS

**Tools :**

Standard tool kit including 1.5 mm, 2 mm, 3 mm and 5 mm allen keys.

**Instruments :**

- Digital multimeter with an accuracy of 1%, capable of measuring 150 V AC and 10 mA DC, and capable of indicating true RMS value within 1 sec.
- Standard calculator.

**Power Supply :**

Prior to starting the installation, inspect the power supply and confirm that it is 120VAC ±10%, and a 3 wire GROUNDED circuit, separately connected to the circuit breaker panel with an over current protection device rated for 15 A (Refer to Page 5, [2] ELECTRICAL REQUIREMENTS).

**Record the voltage reading of power supply on "Assembler's Installation Report".**

#### [ 2 ] UNPACKING

Unpack the entire contents of the shipping carton. Included within the shipping carton are :

<u>Hardware</u>	<u>Quantity</u>
Head with Regular Cone -----	1
Main Controller-----	1
Screw for chassis (M4 x 10 mm)-----	4
Screw for chassis (M4 x 20 mm)-----	1
Screw for nylon clamp on wall plate (M4 x 10 mm) -----	1
Stopper Ring -----	1
Nylon Clamp (3/8") -----	1
Insulation Tube for interconnecting wires -----	1
Front cover seal -----	4
Wall Plate -----	1
Lag Screws for wall plate (ø9 x 75 mm) -----	4
Arm Mounting Bracket -----	1
Machine Bolt (M8 x 20 mm) -----	3
Washer (M8) -----	3
Sub Controller -----	1
Sub Controller Mounting wood screw (ø4.1 x 20 mm) -----	3
Head key -----	1
Arm collar -----	1
Balance Arm -----	1
Balance Arm Wrench -----	1
Horizontal Arm W/2 x End Caps -----	1
Brake Screw (M6 x 6 mm) -----	2
Brake Plug (Brass Plug ø5 X 4 mm) -----	2
Retaining Bolt (M6 x 35 mm) -----	2
Stopper Screw (M6 x 15 mm) -----	1
Brake Spring (ø5 x 11 mm) -----	1
<u>Documentation</u>	<u>Quantity</u>
Installation manual -----	1
Operators manual -----	1
Limited Warranty / Report Form -----	1
Wall mounting Template -----	1
FDA Form 2579 -----	1

**Inspect contents of shipping carton for damage or missing components.**



### [ 3 ] MAIN CONTROLLER AND ARM INSTALLATION

The instructions given below are for mounting the main controller assembly on two 2 x 4 wood studs with 16 inch (406mm) centers. Should the PHOT-XII MODEL 303 be mounted in a manner other than what is specified here, the wall and the strength of the hardware used must be checked and verified as being adequate to withstand a 100 pound (45kg) shear load and a 450 pound (205kg) withdrawal force at each of the four (ø9 x 75mm) lag screws. When using concealed wiring, a flush mounted junction box with the necessary conduit and wiring must be pre-installed at 44-7/8 inches (1140mm) from the floor and between the two studs (refer to wall mounting template).

#### A. WALL PLATE OF MAIN CONTROLLER

##### ⚠ WARNING

**Make sure the power supply is turned OFF at the circuit breaker panel.**

1. Tape the wall mounting template to the wall, positioning it so that the holes for mounting plate lag screws are aligned with the vertical 2 x 4" studs.

**NOTE :** Confirm that the location of concealed wiring matches to the access hole of wall plate template.

2. Mark the hole locations for the mounting plate lag screws.
3. Use a 3/16" (5mm) dia. drill to make a pilot hole approximately 2" (50mm) deep for each mounting plate lag screws.

##### ⚠ CAUTION

**Do not use a drill larger than 3/16" (5mm) dia. for these holes.**

4. Place the wire through the hole into the stud mount wall plate and mount the plate to the stud with the four (ø9 x 75mm) lag screws.

**DO NOT FULLY TIGHTEN.**

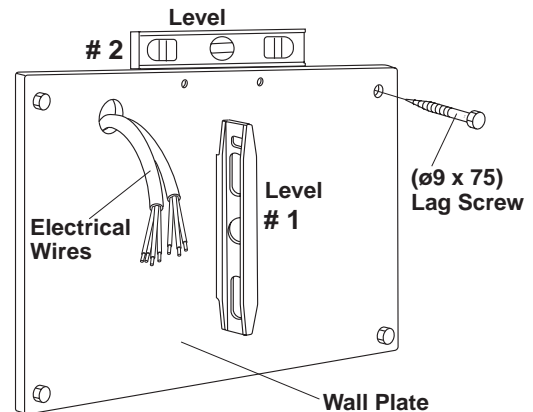
5. Hold the plate firmly against the wall, place a level across the front face. (#1 position in Fig.3-1)  
If the wall is not plumb, use shims behind the plate to level.

6. Place a level across top edge of wall plate, level and tighten lag screws securely. (#2 position in Fig.3-1)

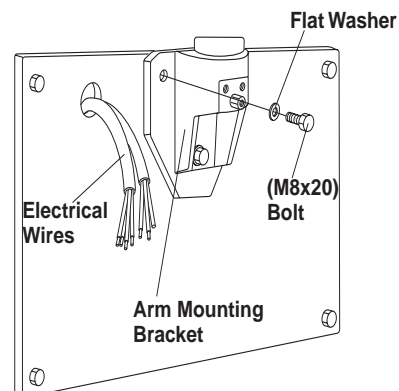
**NOTE :** Final leveling of wall plate is described on page 16.

#### B. ARM MOUNTING BRACKET

1. Using three (M8 x 20mm) bolts with washers in top mounting holes and in lower mounting hole, mount arm mounting bracket to wall plate. (Fig.3-2)



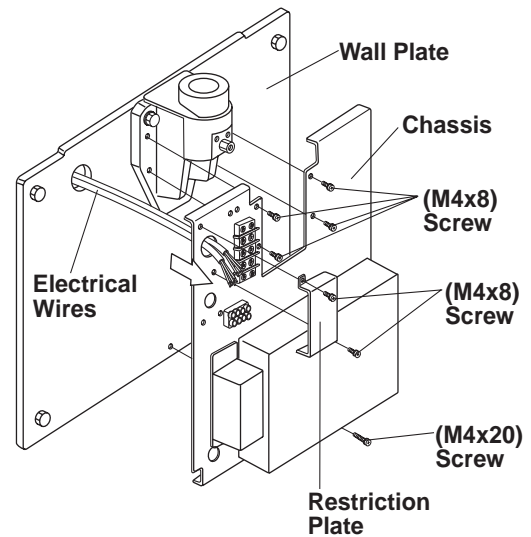
**Fig.3-1** Wall Plate Installation



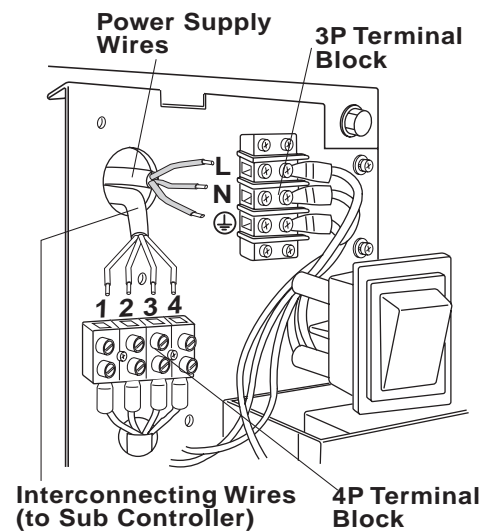
**Fig.3-2** Arm Mounting Bracket Installation

### C. CHASSIS OF MAIN CONTROLLER

1. Remove the restriction plate over the terminal blocks by taking out two (M 4 x 8mm) screws. **(Fig.3-3)**
2. Route electrical interconnecting wires through the access hole on chassis and mount the chassis on the wall plate with four (M4 x 8mm) screws and one (M4 x 20mm) screw. **(Fig.3-3)**
3. Put the supplied insulation tube on the interconnecting wires to keep sufficient insulation against the power supply wires.
4. Cut the wires to workable length and strip 3/8" of insulation for power supply wires and 3/16" for interconnecting wires for Sub Controller. Connect power supply wires to **3P** terminal block and interconnecting wires to **4P** terminal block. **(Fig.3-4)**
5. Reattach the restriction plate. **(Fig.3-3)**



**Fig.3-3** Attaching Chassis to Wall Plate



**Fig.3-4** Wires Connection in Main Controller

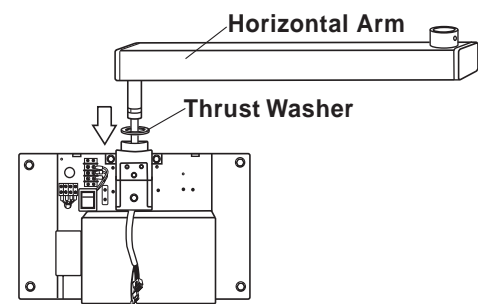
### D. HORIZONTAL ARM

1. Place a thrust washer over the hole on top of the arm mounting bracket. **(Fig.3-5)**  
Insert the cable and horizontal arm into the hole, and mount to the arm mounting bracket, as shown in **Fig.3-5**.
2. Insert two retaining bolts into the upper threaded holes of the arm mounting bracket and tighten securely with a Allen wrench. **(Fig.3-6)**

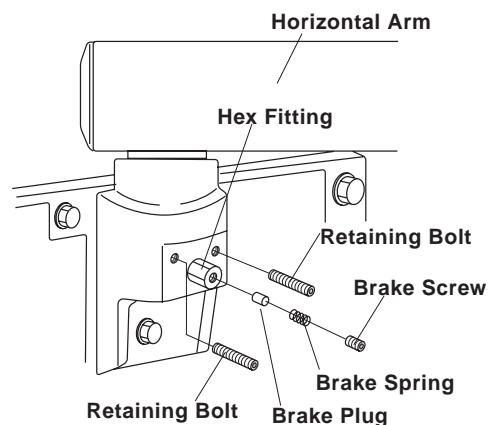
#### **IMPORTANT :**

**The retaining bolts must be installed to ensure that the horizontal arm can not lift out of the arm mounting bracket.**

3. Insert brake plug, brake spring and brake screw (M6 x 6 mm) into the threaded hole of the hex fitting located on the arm mounting bracket. **DO NOT FULLY TIGHTEN. (Fig.3-6)**



**Fig.3-5** Horizontal Arm Installation-1

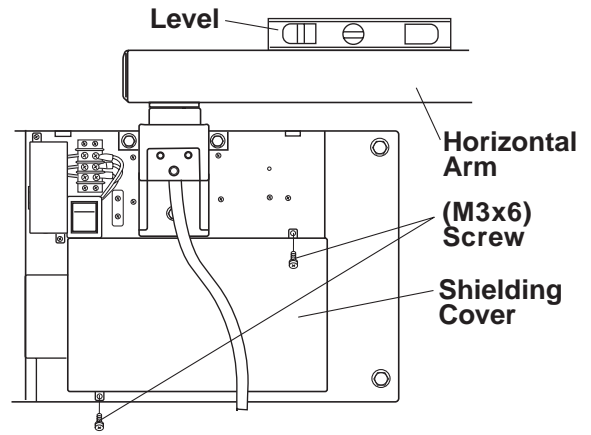


**Fig.3-6** Horizontal Arm Installation-2

- Place a level on the horizontal arm and confirm that the arm is level throughout its left and right swing positions. (Fig.3-7)

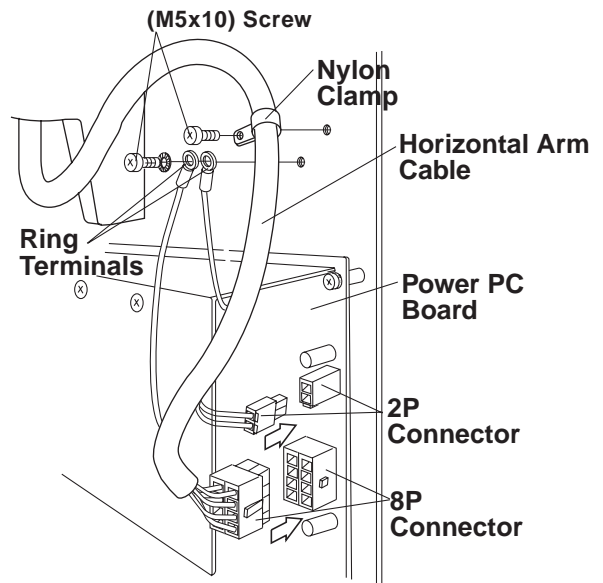
**NOTE :** Final leveling of horizontal arm is described on Page 16.

- Remove two (M3 x 6mm) screws and remove the shielding cover for power PC Board. (Fig.3-7)



**Fig.3-7** Removing Shilding Cover

- Connect **2P** and **8P** connectors of horizontal arm cable to the respective connectors on power PC Board. (Fig.3-8)
- Connect the 2 wires with ring terminals from the arm cable to the chassis with a M5 screw. The arm cable should be secured to the chassis by a nylon cable clamp to prevent damage from twisting. (Fig.3-8)
- Re-install the shielding cover for power PC board again. (Fig.3-7)

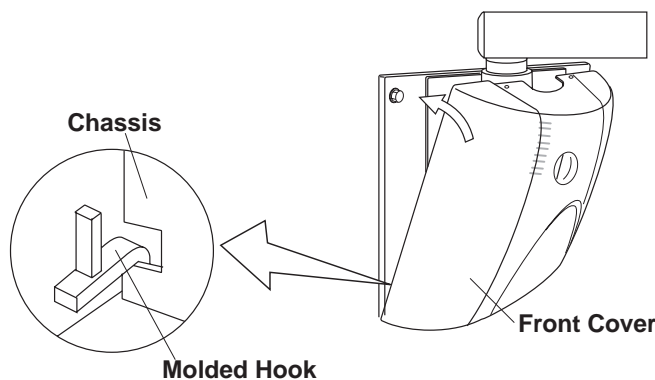


**Fig.3-8** Connecting 2P and 8P Connectors on Power PC Board

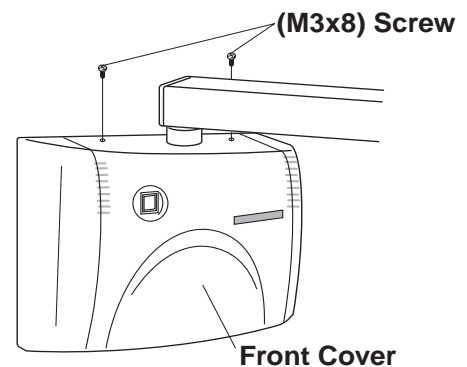
### E. FRONT COVER

**NOTE :** The front cover for the main controller should not be closed until all installation and the post-installation inspections and confirmation are completed.

- The front cover has molded hooks on the inside that attach to notches in the metal chassis. Hook the molded hooks on the front cover onto the chassis notches, and then push the top side toward the wall to close. (Fig.3-9A)
- Install two (M3 x 8mm) screws into the top of the cover and confirm that the cover is securely attached. (Fig.3-9B)



**Fig.3-9A** Attaching Front Cover-1



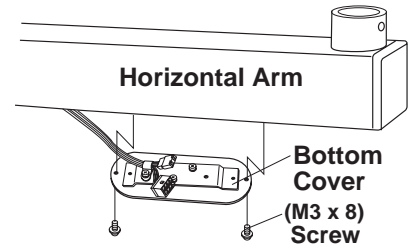
**Fig.3-9B** Attaching Front Cover-2

## F. BALANCE ARM ASSEMBLY

### ⚠ WARNING

**Do not release Arm holding band until the X-ray head has been installed.**

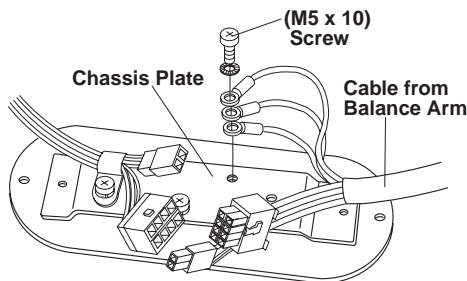
**Balance arm assembly is spring loaded and can cause equipment damage and injury if not handled in the proper manner.**



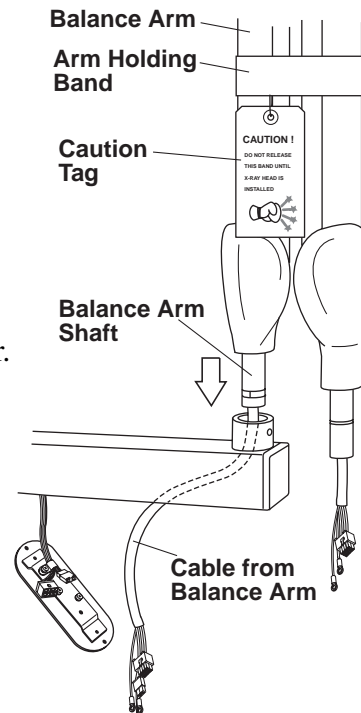
**Fig.3-10** Horizontal Arm Bottom Cover

1. During this procedure, do not remove Arm holding band.
2. Remove two (M3 x 8mm) screws from the underside of the horizontal arm to open the bottom cover. (**Fig.3-10**)
3. Route the cable with 2P and 8P connectors from the balance arm shaft through the horizontal arm. Insert the balance arm into the horizontal arm. The cable should be fed through the bottom cover opening on the bottom of the horizontal arm. (**Fig.3-11**)
4. Secure the 3 wires (Grounded wires) together with ring terminals with the (M5 x 10mm) screw on the bottom cover. (**Fig.3-12A**)

**Note :** Three ring terminals should not protrude from a chassis plate. (**Fig.3-12A**)

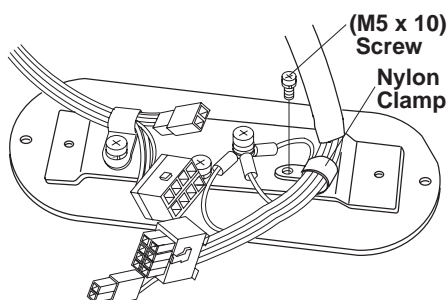


**Fig.3-12A** Attaching Grounded Wires on Bottom Cover

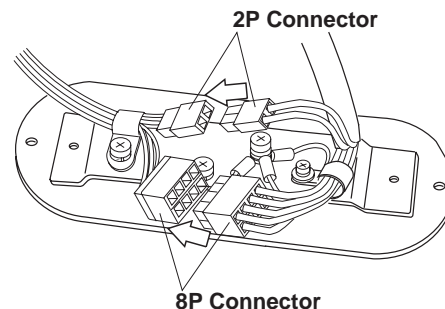


**Fig.3-11** Balance Arm Installation

5. Secure the wires from the balance arm to the bottom cover with the nylon cable clamp to prevent damage from twisting. (**Fig.3-12B**) Then connect the 2P and 8P connectors. (**Fig.3-12C**)
6. Re-attach the bottom cover to the horizontal arm with two screws. (**Fig.3-11**)



**Fig.3-12B** Attaching Balance Arm Cable on Bottom Cover



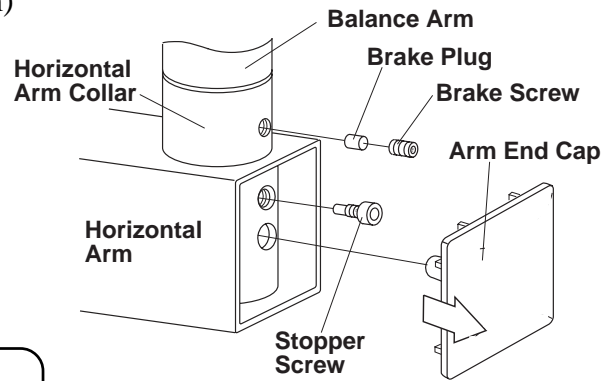
**Fig.3-12C** Connection of Connectors on Bottom Cover

7. Insert the brake plug and brake screw (M6 x 6mm) into the horizontal arm collar. **(Fig.3-13)**  
**Do not fully tighten.**

8. Remove the end cap from horizontal arm. Insert the stopper screw into upper threaded hole inside horizontal arm and tighten securely. Replace the end cap. **(Fig.3-13)**

**⚠ CAUTION**

**If stopper screw is not tightened securely, the Balance Arm can lift out of the horizontal arm.**



**Fig.3-13** Attaching Balance Arm to Horizontal Arm

**[ 4 ] HEAD ASSEMBLY INSTALLATION**

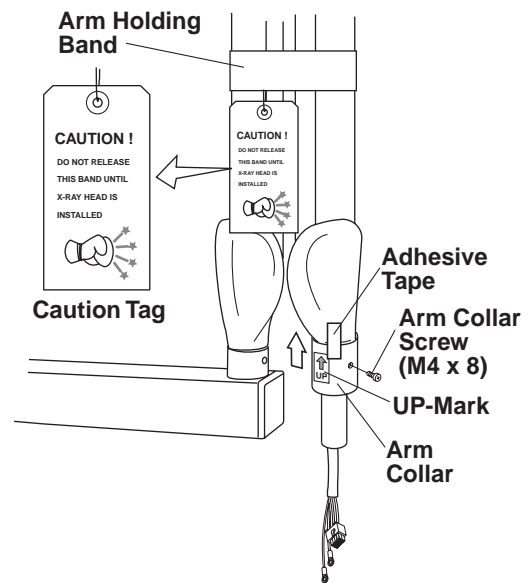
**⚠ WARNING**

**Do not release Arm holding band until the X-ray head has been installed. Balance arm assembly is spring loaded and can cause equipment damage and injury if not handled in the proper manner. Refer to the Caution Tag on the band.**

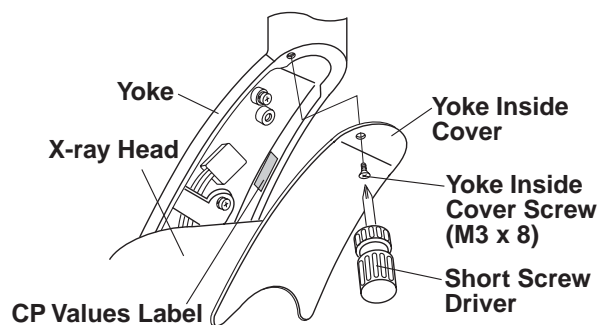
1. Remove the arm collar screw (M4 x 8mm) from the arm collar. Slide the arm collar upward and temporarily hold it in position with adhesive tape. **(Fig.3-14)**
2. Open the yoke inside cover of x-ray head by removing (M3 x 8mm) countersunk screw. **(Fig.3-15)**

**Note :** When opening the yoke inside cover, use a short screw driver.

3. Making sure the stopper ring is placed on the yoke, insert the wiring from the balance arm assembly through the head shaft and into the yoke. **(Fig.3-16)**

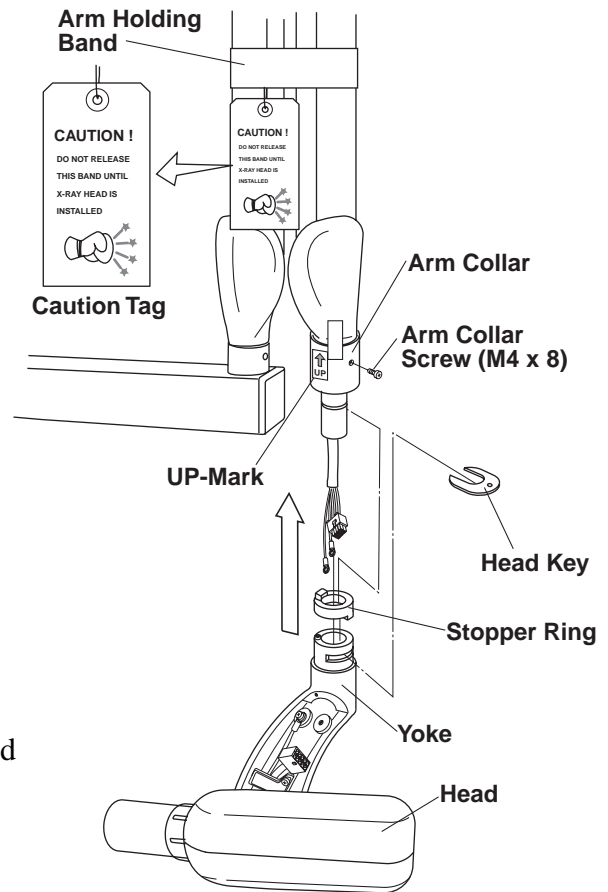


**Fig.3-14** Setting Arm Collar on Balance Arm



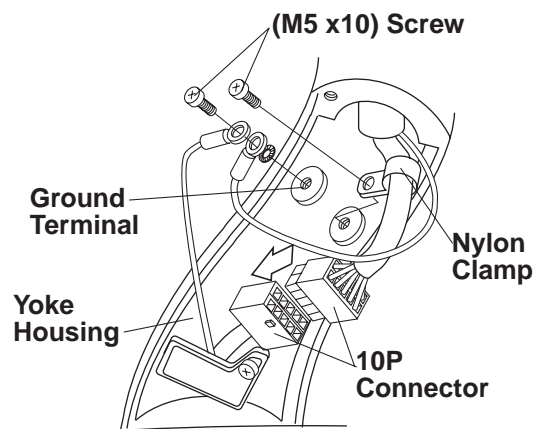
**Fig.3-15** Removing Yoke Inside Cover

4. Insert the shaft of the balance arm into the head yoke, and while holding the head in position, insert the head key securely into the retaining groove. **(Fig.3-16)**
5. Remove adhesive tape and slide the arm collar downward. Fix it in place with the arm collar screw. Remove the UP-mark from the arm collar. **(Fig.3-16)**



**Fig.3-16 X-ray Head Installation**

6. Loosen the (M5 x 10mm) screw and remove the nylon cable clamp from the yoke housing. Place cable clamp on the balance arm cable. Connect the **10P** connectors, and then attach the balance arm cable to the yoke housing with the nylon cable clamp. **(Fig.3-17)**
7. Remove the (M5 x 10mm) screw from the ground terminal inside of the yoke housing. Secure the green ground wires from balance arm and head to the ground terminal with the (M5 x 10mm) screw. **(Fig.3-17)**
8. Reattach the yoke inside cover with the screw (M3 x8mm). Before closing the cover, note the CP values on the CP values label inside of the yoke. **(Fig.3-15)**
9. Remove arm holding band.



**Fig.3-17 Connection 10P Connector in Yoke**

## [ 5 ] SUB CONTROLLER INSTALLATION

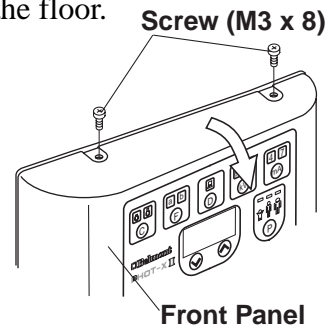
The wall and the strength of the hardware used must be checked and verified as being adequate to withstand a 10 pound (4.5kg) shear load. A flush mounted junction box with the necessary conduit and wiring should be pre-installed at 51-5/8" (1310mm) from the floor.

1. Remove two (M3 x8mm) screws from top of the control box and open the front panel. **(Fig.3-18)**
2. Disconnect the **4P** connector from the timer PC Board. **(Fig.3-19)**
3. Route the interconnecting wires from the main controller through access hole of chassis and mount on the wall with three (ø4.1 x 20mm) wood screws. **(Fig.3-19)**
4. Cut 4 interconnecting wires from main controller to a workable length. Strip 3/16" insulation off the wires and connect them to the **4P** terminal block. Terminal number for each wire should be matched to the terminal number in the main controller. **(Fig.3-20)**

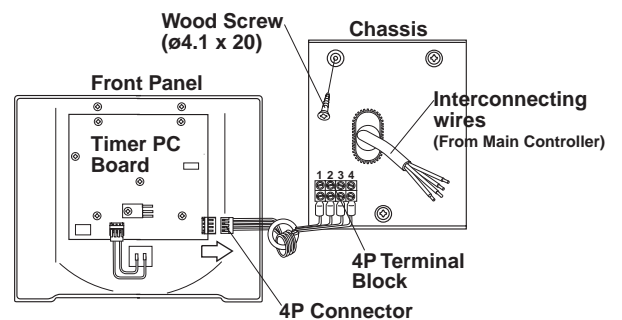
### ▲ CAUTION

**Miswiring causes permanent damage to both timer PC board and power PC board.**

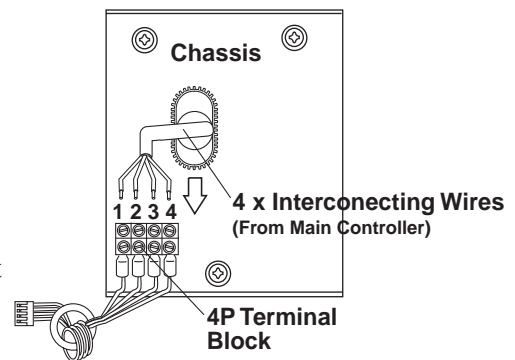
5. If wire length is too long, push it back into the access hole of the wall. This will prevent mechanical damage to the timer PC Board when replacing the front cover.
6. Reattach the **4P** connector to the timer PC Board **(Fig.3-19)**
7. Set the pins located on the bottom of the front panel into holes on the bottom of chassis and attach the front cover to the chassis with two (M3 x 8mm) screws. **(Fig.3-18 & Fig.3-21)**



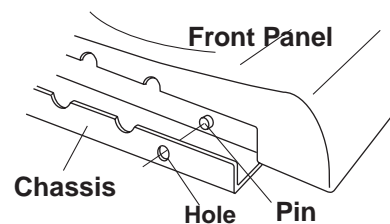
**Fig.3-18** Opening Front Panel



**Fig.3-19** Attaching Sub Controller Chassis



**Fig.3-20** Interconnecting Wires Connection in Sub Controller



**Fig.3-21** Bottom of Sub Controller

## [ 6 ] HAND EXPOSURE SWITCH (OPTION)

An optional hand exposure switch can be connected to the sub controller. Since this exposure switch has a coiled cord, operator can stand the most suitable position for operation.

The exposure switch on the front panel of sub controller and this hand exposure switch can be used. If local code prohibits use of both switches, disconnect the connector of either one of the switches.

1. Confirm the contents of optional hand exposure switch kit. (**Fig.3-22**)

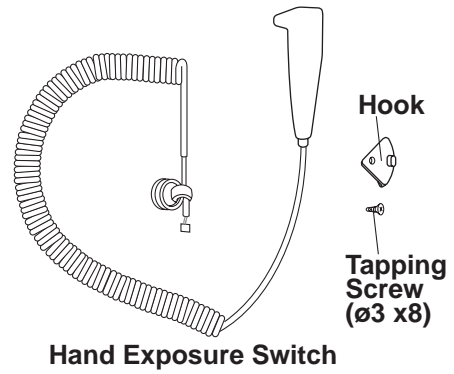
Hand exposure switch ----- 1  
 Hook ----- 1  
 Screw for hook (ø3 x 8mm Tapping screw) ----- 1

2. Remove two (M3 x 8mm) screws from top of the sub controller and open front panel.

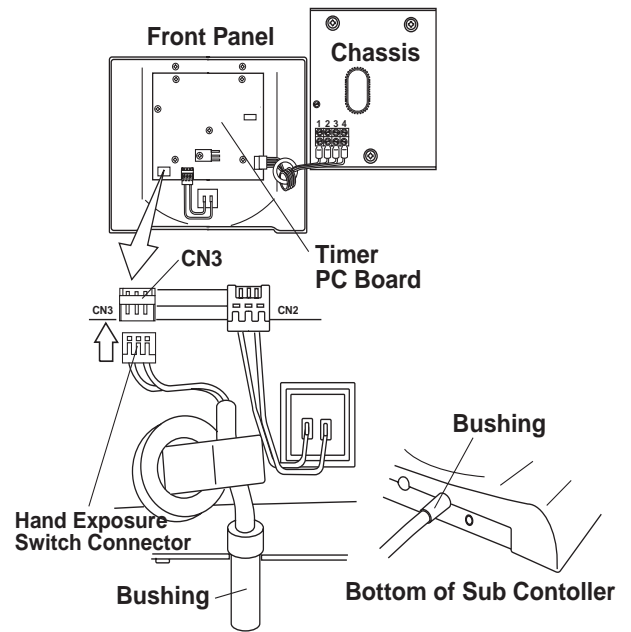
3. Connect the connector at the end of hand exposure switch coil cord to CN3 connector on the timer PC board. (**Fig.3-23**)

4. Insert the bushing of coil cord into the slot at the bottom of the chassis, reattach the front cover and secure two (M3 x 8mm) screws again. (**Fig.3-23**)

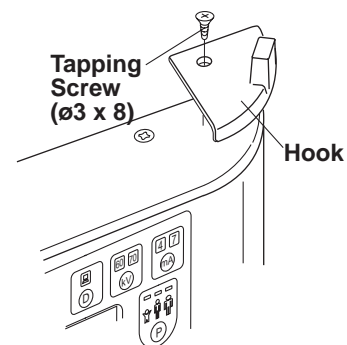
5. Place the hook on the top corner (right or left) of controller and attach it with the tapping screw (ø3 x 8mm). (**Fig.3-24**)



**Fig.3-22** Hand Exposure Switch Kit



**Fig.3-23** Connecting Hand Exposure Switch



**Fig.3-24** Attaching Hand Exposure Switch Hook



## SECTION 4 : POST INSTALLATION INSPECTION

### [ 1 ] ARM ASSEMBLY

1. Incorrect leveling of the wall plate and wall bracket can cause arm drift. First, check leveling with horizontal arm in position #1. (Fig.3-25) If not correct, bracket must be adjusted by placing shims behind the wall plate.

#### IMPORTANT :

If the end of the horizontal arm shown in position #1 is pitched below level, then the tube head will drift away from the wall. If the end of the horizontal arm in position #1 is pitched above level, then the arm will require only minimum adjustment of the brake screw. (Fig.3-13)

2. Check leveling in position #2. if not correct, adjust Horizontal Arm as follows : (Fig.3-25)
  - a. Slightly loosen two top mounting bolts for arm mounting bracket.
  - b. Shift the bracket left or right until the arms are accurately leveled.
  - c. Move the horizontal arm to position # 1.
  - d. Fully tighten two top mounting bolts.
  - e. Fully tighten bottom mounting bolt.

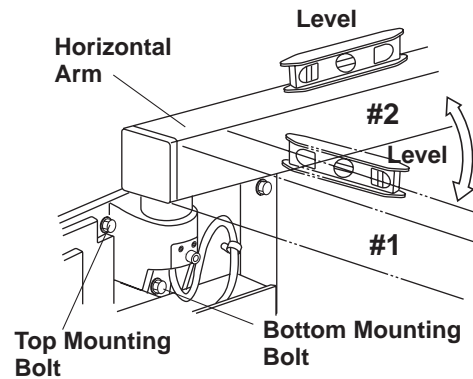


Fig.3-25 Horizontal Arm Adjustment

**NOTE :** Slight tendencies to drift can be corrected by tightening brake screw in horizontal arm. Do not tighten beyond what is required to prevent drift.

### [ 2 ] BALANCE ARM TENSION ADJUSTMENT

1. Place the balance arm assembly into position.
2. If either balance arm drifts higher or lower from the set position, remove the spring adjuster cover and adjust the balance arm spring tension with the balance arm wrench. (Fig.3-26)

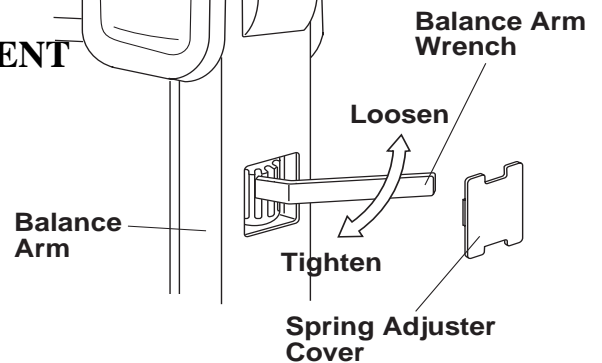


Fig.3-26 Balance Arm Tension Adjustment

### [ 3 ] HEAD POSITIONING

- A. Place head into position.
- B. If head drifts from the set position, adjust the brake screws according to the following procedures. (Fig.3-27)
  1. Loosen the yoke side cap screw (ø3 x 8mm tapping screw) and remove the yoke side cap.
  2. Adjust the six brake screws using a screw driver.
  3. After adjustment, reattach the yoke side cap and screw.

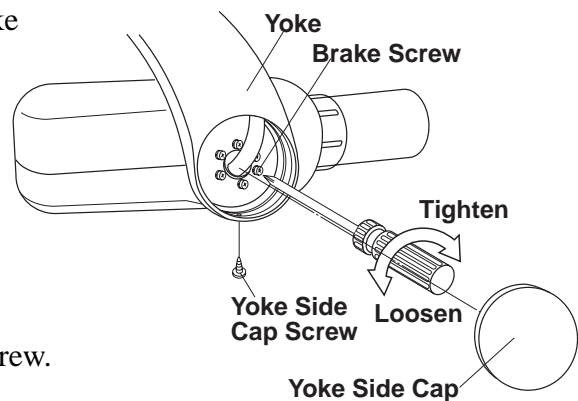
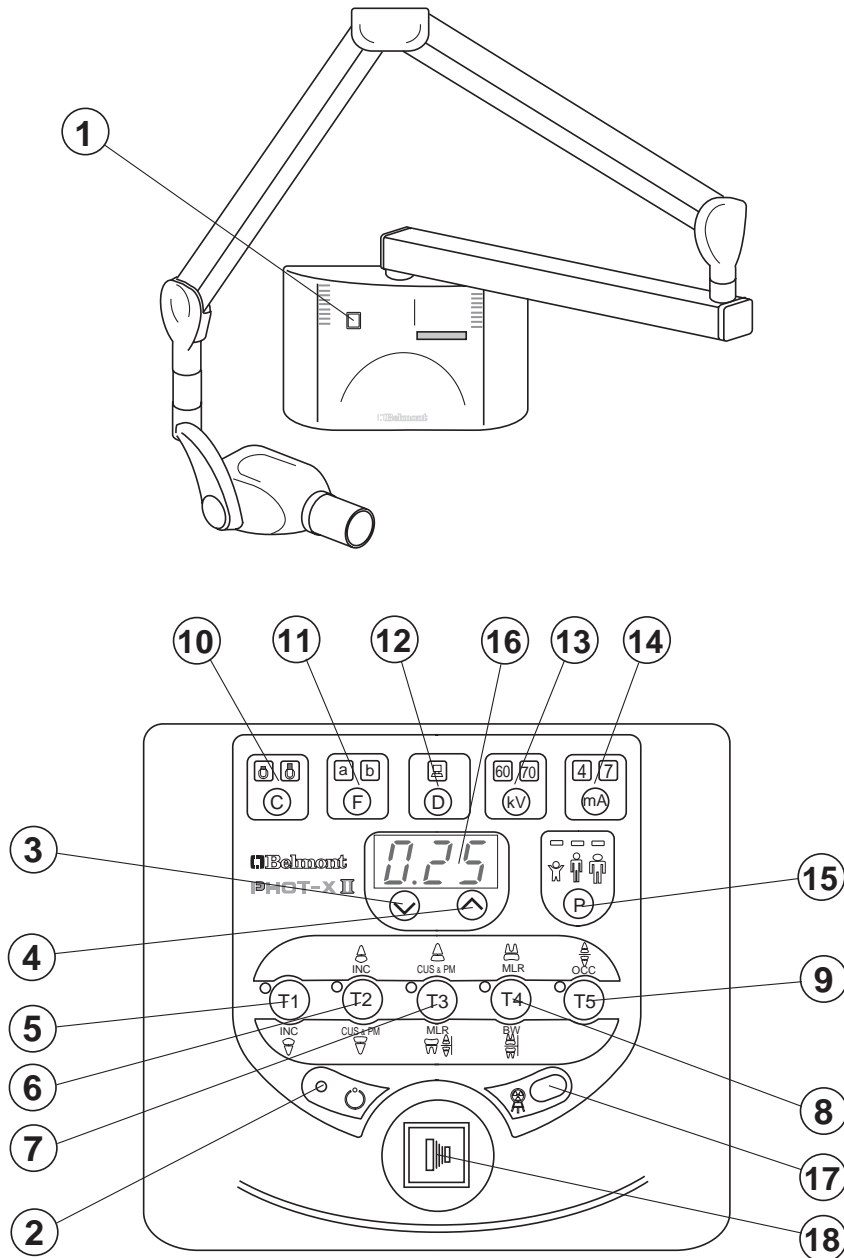


Fig.3-27 Head Positioning

**SECTION 5 : CONTROL IDENTIFICATION AND OPERATION**  
**[ 1 ] MAJOR COMPONENTS AND CONTROL IDENTIFICATION**



**Fig.5-1 Major Components and Control Identification**

- |   |                                 |
|---|---------------------------------|
| ① Main Power Switch                     | ⑩ Cone Type Selection Switch    |
| ② Ready Light                           | ⑪ Film Speed Selection Switch   |
| ③ Exposure Time Adjusting Switch (Down) | ⑫ Digital Imaging Switch        |
| ④ Exposure Time Adjusting Switch (Up)   | ⑬ kV Selection Switch           |
| ⑤ Tooth Selection Switch (T1)           | ⑭ mA Selection Switch           |
| ⑥ Tooth Selection Switch (T2)           | ⑮ Patient Size Selection Switch |
| ⑦ Tooth Selection Switch (T3)           | ⑯ Exposure Time Display Window  |
| ⑧ Tooth Selection Switch (T4)           | ⑰ Exposure Warning Light        |
| ⑨ Tooth Selection Switch (T5)           | ⑱ Exposure Switch               |

## [ 2 ] FUNCTION OF CONTROLS

### ① Main Power Switch



Pushing the upper side of this switch to the ON position energizes the x-ray unit. (Ready light and pre-select light for cone type, film or digital, kV, mA, and patient size illuminate.) It is recommended to keep this switch OFF when the unit is not in use, in order to prevent an accidental exposure.

**IMPORTANT : To prevent the risk of an accidental exposure, push the lower side of this switch to the OFF position, when the unit is not in use.**

### ② Ready Light

This light illuminates when the line voltage is within operable range (108 ~ 132Vac). When this light is not on, exposure can not be made.

### ③ ④ Exposure Time Adjusting Switches

By momentarily pushing the  (or ) switch, the exposure time displayed increases (or decreases) by one increment. By keeping the switch depressed more 2 sec., the exposure time displayed increases (or decreases) continuously until the switch is released.

Model 303 has the following 24 exposure time settings :

0.00, 0.01, 0.02, 0.03, 0.04, 0.05, 0.06, 0.08, 0.10, 0.13, 0.16, 0.20, 0.25, 0.32, 0.40  
0.50, 0.63, 0.80, 1.00, 1.25, 1.60, 2.00, 2.50, 3.20 (sec.)

### ⑤ ~ ⑨ Tooth Selection Switches (T1 ~ T5)

Pushing one of these switches sets the exposure time automatically for the following ⑩ ~ ⑮.

⑤ T1 : Incisor of Mandible

⑥ T2 : Incisor of Maxilla, Cuspid & Premolar of Mandible

⑦ T3 : Cuspid & Premolar of Maxilla, Molars of Mandible, Bite Wing

⑧ T4 : Molar of Maxilla, Bite Wing Molars

⑨ T5 : Occlusal

If the T1 switch ⑤ is depressed more than 3 sec., unit goes into “ Lock Mode”.

In lock mode, the only functional switch is the power switch. To exit from the lock mode, depress the T1 switch more than 3 sec. again.

### ⑩ Cone Type Selection Switch

Depressing this switch for more than 2 sec. selects the cone type : 8” standard cone or 12” optional long cone. (If the optional rectangular cone is to be used, select the 8” standard cone setting.)

### ⑪ Film Speed Selection Switch

a. PHOT-X II has 16 film speed settings : (F.00 ~ F.15)

Two speed settings are pre-set at the factory (a & b) and can be selected with ⑰.

a = Film speed No. F.09 (equivalent to ISO speed group “ D” or Kodak Ultra-Speed film)

b = Film speed No. F.05 (equivalent to ISO speed group “ F/E” or Kodak InSight film)

b. Pushing this switch momentarily displays the selected film speed setting in the **Exposure Time Display Window** ⑰.

Depressing this switch for more than 2 sec. changes the film type being selected.

c. If the **Digital Imaging Switch** ⑱ is depressed, both of the film speed indicating light (a & b) are turned off.

### ⑫ Digital Imaging Switch

If a digital imaging system is used, shorter exposure time is often required. PHOT-X II has 16 speeds for digital imaging : (d.00 ~ d.15). Pushing this switch momentarily displays the speed being selected in the **Exposure Time Display Window** ⑰. With the factory speed setting d.06, the exposure time becomes half of F.06 setting.

**TABLE 1. Speed Setting and Exposure Time (Regular Cone)** [ unit : sec.]

Speed Setting	kV	mA	Child					Adult					Large Adult				
			T1	T2	T3	T4	T5	T1	T2	T3	T4	T5	T1	T2	T3	T4	T5
F.09	60	4	0.16	0.16	0.20	0.25	0.32	0.25	0.32	0.32	0.40	0.63	0.32	0.40	0.40	0.50	0.80
		7	0.08	0.10	0.13	0.13	0.20	0.13	0.16	0.20	0.25	0.32	0.16	0.20	0.25	0.32	0.40
	70	4	0.10	0.13	0.16	0.16	0.25	0.16	0.20	0.25	0.32	0.40	0.20	0.25	0.32	0.40	0.50
F.05	60	4	0.06	0.08	0.08	0.10	0.16	0.10	0.13	0.16	0.16	0.25	0.13	0.16	0.20	0.20	0.32
		7	0.03	0.04	0.05	0.06	0.08	0.06	0.06	0.08	0.10	0.13	0.08	0.08	0.10	0.13	0.16
	70	4	0.04	0.05	0.06	0.08	0.10	0.08	0.08	0.10	0.13	0.16	0.10	0.10	0.13	0.16	0.20
d.06	60	4	0.04	0.05	0.05	0.06	0.10	0.06	0.08	0.10	0.10	0.16	0.08	0.10	0.10	0.13	0.20
		7	0.02	0.03	0.03	0.04	0.10	0.04	0.04	0.05	0.06	0.08	0.05	0.05	0.06	0.08	0.10
	70	4	0.03	0.03	0.04	0.04	0.06	0.05	0.05	0.06	0.08	0.10	0.06	0.06	0.08	0.10	0.13
		7	0.02	0.02	0.02	0.03	0.04	0.03	0.03	0.04	0.04	0.06	0.03	0.04	0.05	0.05	0.08

**TABLE 2. Speed Setting and Exposure Time (Long Cone)** [ unit : sec.]

Speed Setting	kV	mA	Child					Adult					Large Adult				
			T1	T2	T3	T4	T5	T1	T2	T3	T4	T5	T1	T2	T3	T4	T5
F.09	60	4	0.40	0.50	0.63	0.63	1.00	0.63	0.80	1.00	1.00	1.60	0.80	1.00	1.25	1.25	2.00
		7	0.25	0.25	0.32	0.40	0.50	0.40	0.50	0.50	0.63	1.00	0.50	0.63	0.63	0.80	1.25
	70	4	0.32	0.32	0.40	0.50	0.63	0.50	0.63	0.63	0.80	1.25	0.63	0.80	0.80	1.00	1.60
F.05	60	4	0.16	0.20	0.25	0.25	0.40	0.25	0.32	0.40	0.50	0.63	0.32	0.40	0.50	0.50	0.80
		7	0.10	0.10	0.13	0.16	0.25	0.16	0.20	0.25	0.25	0.40	0.20	0.25	0.25	0.32	0.50
	70	4	0.13	0.13	0.16	0.20	0.25	0.20	0.25	0.25	0.32	0.50	0.25	0.32	0.32	0.40	0.63
d.06	60	4	0.10	0.13	0.16	0.16	0.25	0.16	0.20	0.25	0.25	0.40	0.20	0.25	0.32	0.32	0.50
		7	0.06	0.08	0.08	0.10	0.13	0.10	0.13	0.13	0.16	0.25	0.13	0.16	0.16	0.20	0.32
	70	4	0.08	0.08	0.10	0.13	0.16	0.13	0.16	0.16	0.20	0.32	0.16	0.20	0.20	0.25	0.40
		7	0.04	0.05	0.06	0.06	0.10	0.06	0.08	0.10	0.13	0.16	0.08	0.10	0.13	0.13	0.20

**⑬ kV Selection Switch**

Momentarily depressing this switch will change the tube potential to 60 or 70 kV. Since the tube potential is constant DC, a 60 kV setting on the PHOT-X II is similar to a 70 kVp setting on a conventional x-ray. If either the **Film Speed Switch** ⑪ or **Digital Imaging Switch** ⑫ is depressed, 60kV is automatically selected.

**⑭ mA Selection Switch**

Momentarily depressing this switch will change the tube current setting (4 or 7 mA).

If the **Digital Imaging Switch** ⑫ is depressed, 4 mA is automatically selected and if the **Film Speed Switch** ⑪ is depressed, 7 mA is automatically selected.

**⑮ Patient Size Selection Switch**

This switch alters the selection of patient type/size to be radiographed (child adult large child) and sets the exposure time automatically.

**NOTE : Setting or adjusting the exposure time manually (with ⤴ or ⤵ switch) supersedes ⑤ ~ ⑮ functions.**

**⑯ Exposure Time Display Window**

This window displays the selected exposure time. If an abnormal condition exists or a malfunction occurs, an Error Code is displayed. (See Section : [4] **ERROR CODES**)

**⑰ Exposure Warning Light**

Illumination of this light indicates the unit is producing x-radiation.

**⑱ Exposure Switch**

This switch initiates radiographic exposure. When making an exposure, depress and hold this switch until the **Exposure Warning Light** ⑰ and the audible warning shut off. Failure to keep this switch depressed will result in the premature termination of the exposure and error code E.00 will be displayed in **Exposure Time Display Window** ⑯.

### [ 3 ] OPERATING PROCEDURES

1. Turn ON the Main Power Switch ①.
2. Confirm that Ready Light ② is illuminated.

**NOTE :** The ready light will not illuminate unless the incoming line voltage is correct and within the x-ray's operable range (108 ~ 132VAC.).

3. Select the appropriate tooth type (⑤ ~ ⑨), and confirm the pre-selected conditions (cone type, film or digital, kV, mA and patient size) are suitable for exposure.

**NOTE :** To manually set the exposure time, depress either of the manual Exposure Time Adjust Switches ( ^ or v ) until the desired exposure time appears in the Exposure Time Display Window ⑩. While the unit is in manual mode, other selection switches (⑤ ~ ⑯) do not affect exposure time. (All of the tooth selection lights are off.) To return to the automatic exposure time selection mode, depress any one of Tooth Selection Switches (⑤ ~ ⑨).

4. Depress the Exposure Switch ⑱. When the Exposure Switch is depressed, the Exposure Warning Light ⑰ illuminates and the audible warning sounds. Do not release the Exposure Switch until the Exposure Warning Light and audible warning automatically shut off. Failure to keep the switch depressed will result in exposure being terminated prematurely.
5. To continue to radiograph other teeth, just select appropriate Tooth Selection Switches (⑤ ~ ⑨).

**IMPORTANT :** To protect x-ray tubehead from heat accumulation, wait for a time interval that is equal to 50 times the selected exposure time before making additional exposures. (Example : a 25 sec. wait is necessary between exposures that are 0.5 sec. in duration.)

6. Turn OFF the Main Power Switch ① in order to prevent accidental exposure when the unit is not in use.

**NOTE :** If the unit is left over 8 min. without being operated and Main Power Switch ① is kept on, figure "1" runs through the Exposure Time Display Window ⑩. This does not mean that malfunction of the unit has occurred ; this is an energy saving feature. The unit returns to ready condition by pressing any one of the switches, except the Exposure Switch ⑱.

### [ 4 ] OPTIONAL HAND EXPOSURE SWITCH

An optional hand exposure switch can be connected to the sub controller. Since this exposure switch has a coiled cord, operators can stand in the most suitable position for operation.

As controller has separate connector for this exposure switch, both exposure switch ⑱ on the front panel of sub controller and this hand exposure switch can be used.

If local code prohibits use of both, ask installer to disconnect the connector of either switch.

## [ 5 ] ERROR CODES

If an abnormal condition exists in the unit, or a malfunction occurs, an error code is displayed in the Exposure Time Display Window ⑯. Please refer to the Table below.

Error Code	Condition	Step to be Taken	Possible Solution
E.00	Exposure switch was released before exposure termination.	All the tooth selection lights blink. Depress one of the tooth switches.	Release the exposure switch after the exposure light turns off.
E.01	Exposure switch was depressed within 10 sec. of previous exposure.	A 10 sec. delay is built in between each exposure.  Release the exposure switch.	There should be a " wait" interval of 50 times the exposure time between successive exposures.
	Exposure time was set and exposure switch was depressed within 3 sec. of the power switch being turned on.		Wait a minimum 3 sec. after the main power switch is turned on before pressing the exposure switch.
E.02	Line voltage was less than 90% of rated voltage.		If line voltage is less than 90% of rated voltage, correct it by using a step-up transformer (*)
E.03	Line voltage was more than 110% of rated voltage.		If line voltage is less than 110% of rated voltage, correct it by using a step-down transformer (*)
E.05	Tube current at last portion of exposure was less than 3 mA at 4 mA setting or less than 5.25 mA at 7 mA setting.	Turn off the main power switch and wait for approximately 2 min. Turn on the main power switch again.	Conduct the confirmation of tube current described in section 6.
E.06	Tube current at last portion of exposure was more than 5 mA at 4 mA setting or more than 8.75 mA at 7 mA setting.		
E.07	During the exposure, tube current becomes less than 2 mA at 4mA setting or less than 3.5 mA at 7 mA setting.		
E.08	During the exposure, tube current becomes more than 6 mA at 4mA setting or less than 10.5 mA at 7 mA setting.		
E.09	Setting for pre-heating time is out of range.		
E.10	Exposure switch or exposure circuit had been ON, when main power switch is turned on.		
E.11	Tube current is detected during pre-heating period.		
E.12	Tube current is detected when main power switch is turned on.		
E.14	Tube potential at last portion of exposure was less than 50 kV at 60 kV setting or less than 60 kV at 70 kV setting.		

Error Code	Condition	Step to be Taken	Possible Solution
E.15	Tube Potential at last portion of exposure was more than 70 kV at 60 kV setting.	Turn off the main power switch and wait for approximately 2 min. Turn on the main power switch again.	Refer to the service manual.
E.16	During the exposure, tube potential becomes less than 40 kV at 60 kV setting or less than 50 kV at 70 kV setting.		
E.17	During the exposure, tube potential becomes more than 80 kV.		
E.18	Excess current was detected in primary circuit of filament transformer.		
E.19	Excess current was detected in primary circuit of high voltage transformer.		
E.20	Exposure switch was depressed when tube head temperature was over 60°C.	Release the exposure switch.	Turn off the main power switch and wait until temperature goes down.
E.22	Failure of electrical communication between the power PCB and timer PCB.	Turn off the main power switch and wait for approximately 2 min.	Refer to the service manual.
E.23	Some switch had been on, when the main power switch is turned on. (Except the exposure switch.)	Turn on the main power switch again.	

(\*) Should a step up or down transformer be required to follow local and national electrical code for electrical ratings (120VAC, 60Hz, Single Phase, 1.3kVA) and installation.

## [ 6 ] MAINTENANCE

PHOT-X II MODEL 303 x-ray unit requires post installation confirmation and periodic maintenance checks to be performed by dealer service personnel. These procedures ensure that the x-ray unit is functioning within the manufacturer's specifications and remain in compliance with the Standard.

It is the responsibility of the owner of the unit to see that these maintenance checks are done **once every 6 months** and that they are performed by a trained, certified service technician.

The specific instructions to perform these checks are located within this Installation Manual.

A. Line voltage confirmation (page 23 ~24)

B. Tube potential and Tube current confirmation (page 23)

C. Inspection of arm and head movement (page 16)

D. Mechanical safety

1. The wall plate should be checked to confirm that it is securely attached to the wall.
2. The arm mounting bracket should be checked to confirm that it is securely attached to the wall mounting plate. The arm mounting bracket must be level horizontally and vertically.
3. Check and verify that the horizontal arm is not raising up and out of the arm mounting bracket.

This should be verified routinely by treatment room personnel.

## SECTION 6 : POST INSTALLATION CONFIRMATION

### [ 1 ] CONFIRMATION OF POWER SUPPLY VOLTAGE

As specified in Electrical Requirements (page 5), power supply voltage must be within the operable range of 108 ~ 132 VAC. Confirm the power supply voltage again before turning on the unit.

1. Open the front panel of main controller by loosening two screws on top of the controller.
2. Set the range of digital multimeter at 200 VAC, connect probes of multimeter to L and N of the 3P terminal block.

#### **▲ WARNING**

**Do not touch the restriction plate (refer to Fig.3-3) with the probes of multimeter during measurement, or a short circuit occurs.**

3. Confirm that the reading is  $120V \pm 10\%$  (108 ~ 132 VAC).

**NOTE** : PHOT-X II MODEL 303 x-ray can not be operated unless the power supply voltage is within this range.

### [ 2 ] CONFIRMATION OF TUBE POTENTIAL COMPENSATION VALUE

Tube potential is kept to be the constant and specified value by the feed-back control system. High voltage is converted into low voltage feed back signal by the voltage divider. The precision of tube potential depends on the accuracy of this voltage divider, although each divider has little deviation. To compensate this deviation, we prepare the compensation value for each tube head. Before making an exposure, check this value to be same as the value stored in the subcontroller.

1. Confirm the tube potential compensation (CP) values for 60kV and for 70kV written on the label attached inside of the head yoke.
2. Turn on the main power switch. Keep depressing patient, cone and tube potential switches together until "CP. ○" is displayed in exposure time window. This value is for 60kV and should be the same value on the label. If displayed value is different, press Exposure Time Adjusting Switches (⊖ or ⊕) and make the CP value to be same as the label and press patient switch to store it
3. Press kV switch, then CP value for 70kV will be displayed. This value should be same as the value for 70kV written on the label. If it is different, adjust displayed value by the Exposure Time Adjusting Switches (⊖ or ⊕) and press patient switch to store it.

### [ 3 ] CONFIRMATION OF TUBE CURRENT

PHOT-X II Model 303 x-ray incorporates self diagnose and adjusting system to check if the tube current are within specified ranges at the beginning of exposure.

1. Keep depressing tooth selection switches TI, T4 & T5 together until "h. ○○" is appeared on the exposure time display window
2. Wait until the display changes to be "0.01".
3. Make exposure by depressing the exposure switch.

#### **▲ WARNING**

**X-radiation is generated for 0.01 second.**

4. Repeat step 2. and 3. until "Fin" is displayed. This self diagnose and adjustment is automatically done for all combination of 60kV/70kV and 4mA/7mA.



## [ 4 ] CONFIRMATION OF EXPOSURE WARNING LIGHT & BUZZER

### A. EXPOSURE WARNING BUZZER

1. Make an exposure and confirm that the exposure warning buzzer located within the sub controller is activated during the entire exposure.

### B. EXPOSURE WARNING LIGHT

Exposure warning light is located on the front panel of the sub controller,

1. Make an exposure and confirm that the warning light illuminates during the exposure.

## [ 5 ] CONFIRMATION OF LINE VOLTAGE REGULATION

1. Make sure that main power switch is "OFF".
2. Set the range of digital multimeter at 200 VAC, connect probes of multimeter to L and N of the 3P terminal block in the main controller.

### **⚠ WARNING**

**Do not touch the restriction plate (refer to Fig.3-3) with the probes of multimeter during measurement, or a short circuit occurs.**

3. Turn the main power switch on, and set the exposure time at 2.00 sec. with manual switch at 70kV, 7mA.
4. Record the no-load line voltage (VN) indicated by the multimeter before exposure.
5. Make an exposure and record the load voltage (VL) indicated by the multimeter during exposure.

### **⚠ WARNING**

**X-Radiation is generated for 2 seconds.**

**NOTE :** Read the multimeter when the value is stabilized (about one second after exposure started).

6. Calculate line voltage regulation R(%) in the formula below :

$$R = \frac{VN - VL}{VL} \times 100 \quad \text{Record this value in "Assemblers Installation Report".}$$

**NOTE :** Line voltage regulation must not exceed the range of 2 ~ 5 %. If it is greater than 5%, the size of the power supply wires must be increased. Refer to the power supply requirements outlined on page 5 to determine the correct wire size necessary. If line voltage regulation is within the range, apparent resistance of supply line can be considered to be less than 0.5 OHM.

## SECTION 7 : INITIAL SETTING

### [ 1 ] SPEED SETTING FOR FILM AND DIGITAL IMAGING





#### A. FILM SPEED

Prior to shipment of the x-ray from the factory, the following two film speeds are programmed to be selected by the Film Speed Selection Switch.

a = Film speed F.09 (equivalent to ISO speed group "D", or Kodak Ultra-speed Film)

b = Film speed F.05 (equivalent to ISO speed group "F/E", or Kodak InSight Film)



In addition to these two speeds, PHOT-X II MODEL 303 x-ray can provide 16 different film speeds (F.00 ~ F.15) and any two of them can be programmed for easy selection. If the doctor uses a different film speed, or prefers darker (or lighter) radiographs, the new speed can be programmed as follows. Higher speed settings make films darker. If film speed is increased by 1, exposure time becomes 25 % longer.

1. Keep the kV selection switch and mA selection switch depressed simultaneously for more than 3 seconds. Release the switches if the ready light starts to flash.
2. Push F switch momentarily until the "a" light above the F switch illuminates. The exposure time display window shows the present film speed for "a" setting. (The factory default setting, F.09 should be displayed.) By depressing  or  switch, increase or decrease film speed number until desired number for "a" setting is displayed.
3. To change the "b" setting from the factory default, F.05, push F switch momentarily until the "b" light illuminates. By depressing  or  switch, increase or decrease film speed until the desired number for "b" setting is displayed.
4. Press **T1 switch** to store these settings, then turn the main power switch off.

#### B. SPEED FOR DIGITAL IMAGING

PHOT-X II MODEL 303 x-ray has 16 speeds for digital imaging (d.00 ~ d.15). The factory setting is d.06 and with this setting the exposure time becomes half of F.06 setting.

As the sensitivity is different according to each manufacturer of digital imaging sensors, this setting should be adjusted. To get a darker image, increase the speed setting and to get a lighter image, decrease the speed setting. If the speed setting is increased by 1, exposure time becomes 12 % longer.

1. Keep kV selection switch and mA selection switch depressed simultaneously for more than 3 seconds. Release the switches if the ready light starts to flash.
2. Push D switch momentarily until the light above the D switch illuminates and the exposure time display window shows the present speed setting. (The factory default setting d.06 should be displayed.)
3. By depressing  or  switch, increase or decrease speed until the desired number is displayed.
4. Press **T1 switch** to store these settings, then turn the main power switch off.

**TABLE 1. Speed Setting and Exposure Time (Regular Cone)** [ unit : sec.]

Speed Setting	kV	mA	Child					Adult					Large Adult				
			T1	T2	T3	T4	T5	T1	T2	T3	T4	T5	T1	T2	T3	T4	T5
F.09	60	4	0.16	0.16	0.20	0.25	0.32	0.25	0.32	0.32	0.40	0.63	0.32	0.40	0.40	0.50	0.80
		7	0.08	0.10	0.13	0.13	0.20	0.13	0.16	0.20	0.25	0.32	0.16	0.20	0.25	0.32	0.40
	70	4	0.10	0.13	0.16	0.16	0.25	0.16	0.20	0.25	0.32	0.40	0.20	0.25	0.32	0.40	0.50
		7	0.06	0.08	0.08	0.10	0.16	0.10	0.13	0.16	0.16	0.25	0.13	0.16	0.20	0.20	0.32
F.05	60	4	0.06	0.08	0.08	0.10	0.16	0.10	0.13	0.16	0.16	0.25	0.13	0.16	0.20	0.20	0.32
		7	0.03	0.04	0.05	0.06	0.08	0.06	0.06	0.08	0.10	0.13	0.08	0.08	0.10	0.13	0.16
	70	4	0.04	0.05	0.06	0.08	0.10	0.08	0.08	0.10	0.13	0.16	0.10	0.10	0.13	0.16	0.20
		7	0.02	0.03	0.04	0.04	0.06	0.04	0.05	0.06	0.06	0.10	0.05	0.06	0.08	0.08	0.13
d.06	60	4	0.04	0.05	0.05	0.06	0.10	0.06	0.08	0.10	0.10	0.16	0.08	0.10	0.10	0.13	0.20
		7	0.02	0.03	0.03	0.04	0.10	0.04	0.04	0.05	0.06	0.08	0.05	0.05	0.06	0.08	0.10
	70	4	0.03	0.03	0.04	0.04	0.06	0.05	0.05	0.06	0.08	0.10	0.06	0.06	0.08	0.10	0.13
		7	0.02	0.02	0.02	0.03	0.04	0.03	0.03	0.04	0.04	0.06	0.03	0.04	0.05	0.05	0.08

**TABLE 2. Speed Setting and Exposure Time (Long Cone)** [ unit : sec.]

Speed Setting	kV	mA	Child					Adult					Large Adult				
			T1	T2	T3	T4	T5	T1	T2	T3	T4	T5	T1	T2	T3	T4	T5
F.09	60	4	0.40	0.50	0.63	0.63	1.00	0.63	0.80	1.00	1.00	1.60	0.80	1.00	1.25	1.25	2.00
		7	0.25	0.25	0.32	0.40	0.50	0.40	0.50	0.50	0.63	1.00	0.50	0.63	0.63	0.80	1.25
	70	4	0.32	0.32	0.40	0.50	0.63	0.50	0.63	0.63	0.80	1.25	0.63	0.80	0.80	1.00	1.60
		7	0.16	0.20	0.25	0.25	0.40	0.25	0.32	0.40	0.50	0.63	0.32	0.40	0.50	0.50	0.80
F.05	60	4	0.16	0.20	0.25	0.25	0.40	0.25	0.32	0.40	0.50	0.63	0.32	0.40	0.50	0.63	0.80
		7	0.10	0.10	0.13	0.16	0.25	0.16	0.20	0.25	0.25	0.40	0.20	0.25	0.25	0.32	0.50
	70	4	0.13	0.13	0.16	0.20	0.25	0.20	0.25	0.25	0.32	0.50	0.25	0.32	0.32	0.40	0.63
		7	0.06	0.08	0.10	0.10	0.16	0.10	0.13	0.16	0.20	0.25	0.13	0.16	0.20	0.25	0.32
d.06	60	4	0.10	0.13	0.16	0.16	0.25	0.16	0.20	0.25	0.25	0.40	0.20	0.25	0.32	0.32	0.50
		7	0.06	0.08	0.08	0.10	0.13	0.10	0.13	0.13	0.16	0.25	0.13	0.16	0.16	0.20	0.32
	70	4	0.08	0.08	0.10	0.13	0.16	0.13	0.16	0.16	0.20	0.32	0.16	0.20	0.20	0.25	0.40
		7	0.04	0.05	0.06	0.06	0.10	0.06	0.08	0.10	0.13	0.16	0.08	0.10	0.13	0.13	0.20

## [ 2 ] PRIORITY OF SELECTIONS

Factory default setting :

Cone : Regular cone  
 Film Speed : "a"  
 Digital Imaging : off  
 kV selection : 60 kV  
 mA selection : 7 mA  
 Patient Type : Adult

If necessary, these settings can be changed. For example, if digital imaging is used for pedodontistry, digital imaging and "child" (patient type) should be selected.

1. Keep kV selection switch and mA selection switch depressed simultaneously for more than 3 seconds. Release the switches if the ready light starts to flash.
2. Press D switch momentarily. (Light above D switch illuminates and speed setting for digital imaging is displayed on exposure time display window.)
3. Select the patient type "child" by depressing P switch momentarily.
4. Press **T1 switch** to store these settings, then turn the main power switch off.
5. Cone type, kV and mA selection can be changed by same procedures.

**NOTE :** For digital imaging, 60 kV and 4 mA is recommended to get good contrast and precise exposure time control.

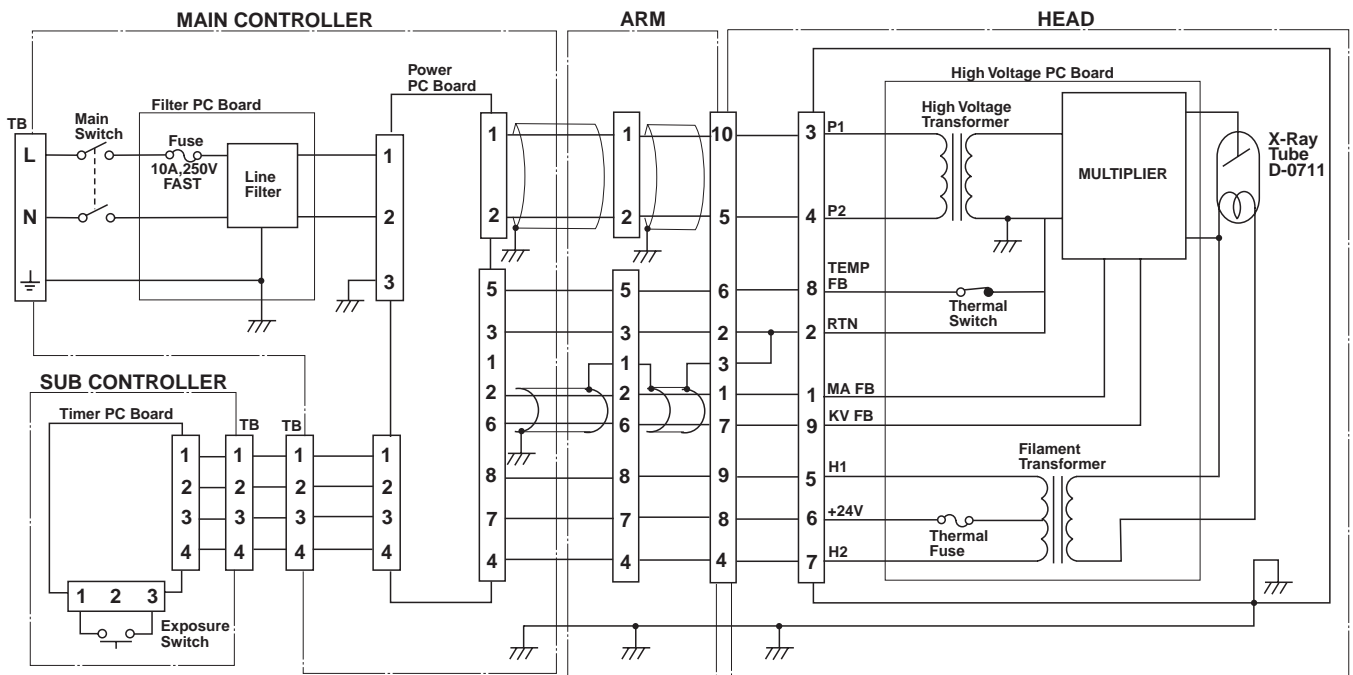
### [ 3 ] ELECTRONIC CHIME ON/OFF

An electronic chime sounds when switches are depressed. If preferred, this sound can be deactivated as follows :

1. Keep T1 and T2 switches depressed together for more than 3 seconds.  
Release the switches if the ready light starts to flash.
2. "bu. 2" will be displayed in exposure time display window.
3. By depressing either ☒ or ☑ switch, display changes to "bu.0".
4. Press **P switch** (Patient type Switch) to store this setting and turn off the main power switch.

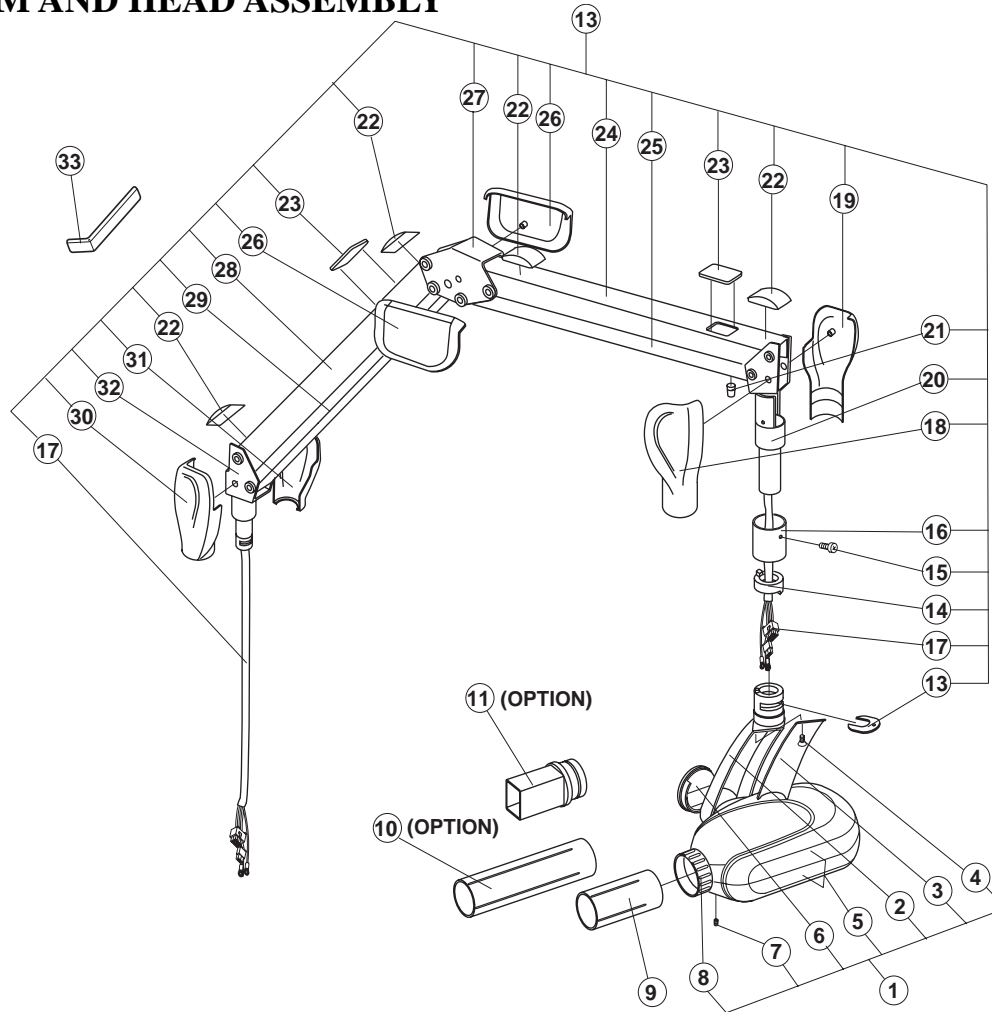
**NOTE :** Exposure Warning Buzzer and alarm sound of error code can not be eliminated.

### APPENDIX 1 : CIRCUIT DIAGRAM



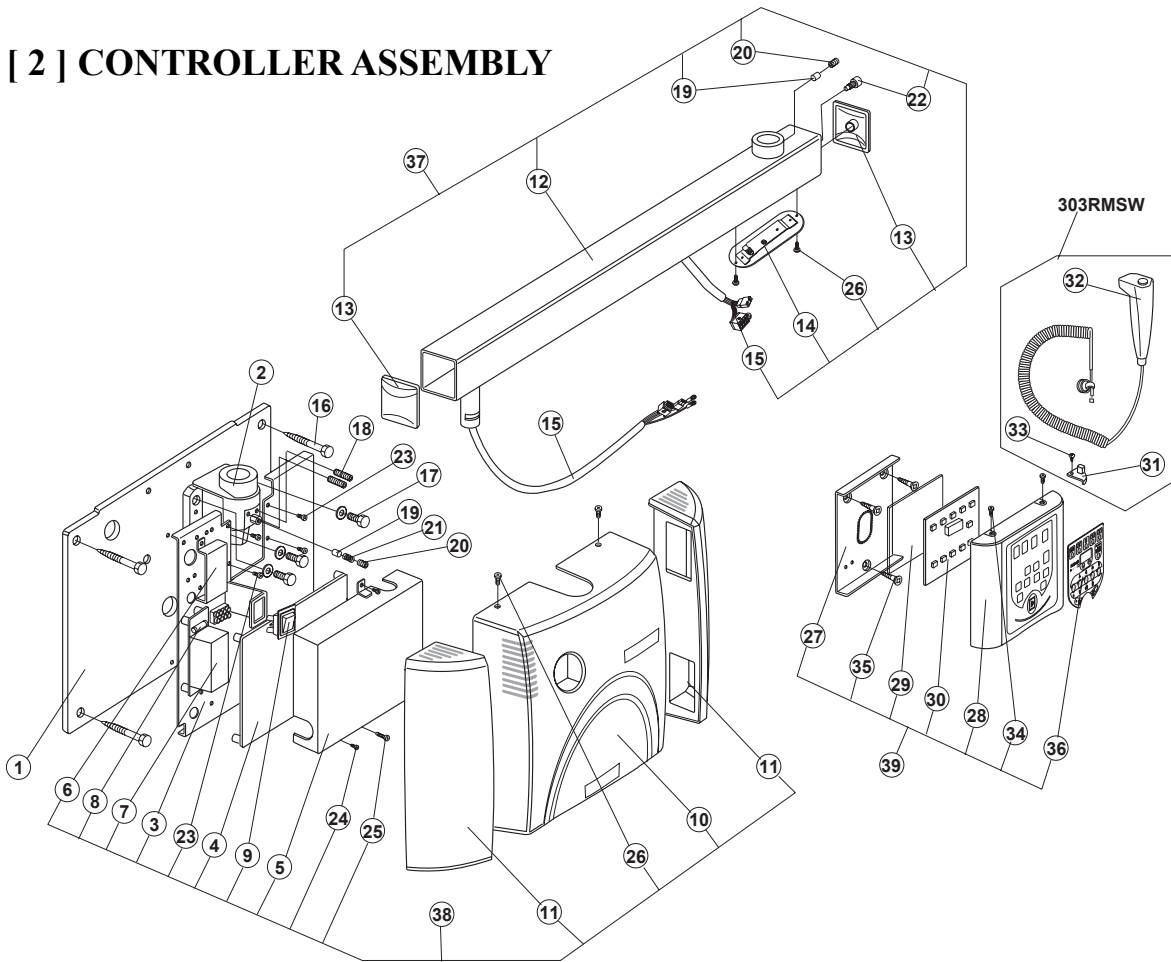
## APPENDIX 2 : PARTS IDENTIFICATION

### [ 1 ] ARM AND HEAD ASSEMBLY



ID.No.	Parts No.	Description	QTY	USA Code
1	E06-EHLL54A0	X-Ray Head Assembly	1	E06-EHLL54A0
2	E06-ECPE24A0	Yoke	1	E06-ECPE24A0
3	E06-ECPJ75A0	Yoke Inside Cover	1	E06-ECPJ75A0
4	-----	Yoke Inside Cover Screw (M3 x 8)	1	-----
5	E06-EHLL55A0	Head Housing Cover Set	1set	E06-EHLL55A0
6	E06-ECQR60A0	Yoke Side Cap	1	E06-ECQR60A0
7	-----	Yoke Side Cap Screw (ø3 x 8)	1	-----
8	E06-ECPJ65A0	Lock Ring	1	E06-ECPJ65A0
9	E06-ECPJ65A0	Regular Cone	1	E06-ECPJ65A0
10	E06-EHLZ72A0	Long Cone (Option)	(1)	303L
11	E06-EHLZ73A0	Rectangular Cone (Option)	(1)	303REC
12	E06-EHLL56A0	Balance Arm Assembly	1	E06-EHLL56A0
13	E06-ECQR62A0	Head Key	1	E06-ECQR62A0
14	E06-ECQR24A0	Stopper Ring	1	E06-ECQR24A0
15	-----	Arm Collar Screw (M4 x 8)	1	-----
16	E06-ECQR31A0	Arm Collar	1	E06-ECQR31A0
17	E06-EFLR12A0	Wire Harness in Balance Arm	1	E06-EFLR12A0
18	E04-ECPE19F0	Left Cover for Joint No.3	1	096ECPE19F0
19	E04-ECPE18F0	Right Cover for Joint No.3	1	096ECPE18F0
20	E06-ECPE16B0	Joint No.3	1	E06-ECPE16B0
21	E04-ECQR33A0	Cushion Absorber	1	096ECQR33A0
22	E04-ECQR27B0	Crevice Cover	4	096ECQR27B0
23	E04-ECQR30C0	Spring Adjuster Cover	2	096ECQR30C0
24	E04-ECPJ60A0	Arm Cover No.2	1	096ECPJ60A0
25	E04-ECPE30B0	Balance Arm No.2	1	096ECPE30B0
26	E04-ECPJ64C0	Cover for Joint No.2	2	096ECPJ64C0
27	E04-ECPJ58B0	Joint No.2	1	096ECPJ58B0
28	E04-ECPJ59A0	Arm Cover No.1	1	096ECPJ59A0
29	E04-ECPE31B0	Balance Arm No.1	1	096ECPE31B0
30	E04-ECPJ63F0	Left Cover for Joint No.1	1	096ECPJ63F0
31	E04-ECPJ62F0	Right Cover for Joint No.1	1	096ECPJ62F0
32	E04-ECPE15B0	Joint No.1	1	096ECPE15B0
33	E04-ECLJ82A0	Balance Arm Wrench	1	096-1082

## [ 2 ] CONTROLLER ASSEMBLY



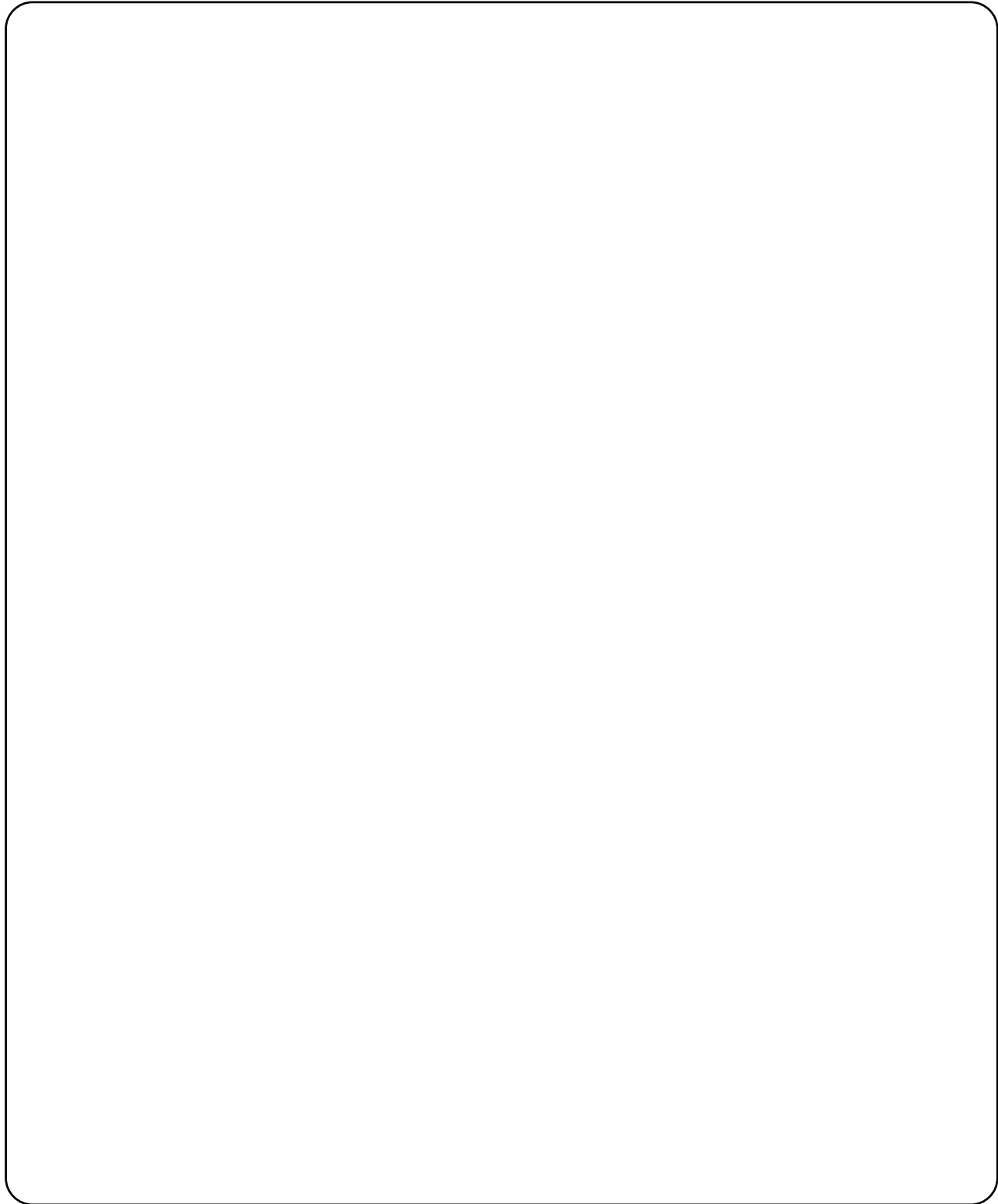
ID.No.	Parts No.	Description	QTY	USA Code
1	E06-ECPJ71B0	Wall Plate	1	E06-ECPJ71B0
2	E06-ECPE29B0	Arm Mounting Bracket	1	E06-ECPE29B0
3	E06-ECPE28B0	Chassis	1	E06-ECPE28B0
4	E06-EHLL22A0	Power PC Board	1	E06-EHLL22A0
5	E06-ECPJ72A0	Shielding Cover	1	E06-ECPJ72A0
6	E06-ECQR63A0	Restriction Plate	1	E06-ECQR63A0
7	E06-EHLL23A0	Filter PC Board	1	E06-EHLL23A0
8	E06-EFPR28A0	Fuse (10A)	1	E06-EFPR28A0
9	E06-EFPR27A0	Main Power Switch	1	E06-EFPR27A0
10	E06-ECPB09B0	Front Cover	1	E06-ECPB09B0
11	E06-ECPE27A0	Side Cover	2	E06-ECPE27A0
12	E06-EHLL27C0	Horizontal Arm Frame	1	E06-EHLL27C0
13	E06-ECQR61A0	Arm End Cap	2	E06-ECQR61A0
14	E06-ECQR70A0	Arm Bottom Cover	1	E06-ECQR70A0
15	E06-EFLR13A0	Wire Harness In Horizontal Arm	1	E06-EFLR13A0
16	-----	Lag Screw ( $\varnothing 9 \times 75$ )	4	-----
17	-----	Machine Bolt ( M8 x 20 )	3	-----
18	E04-ECPR44A0	Retaining Bolt ( M6 x 35 )	2	E04-ECPR44A0
19	E04-ECLS06A0	Brake Plug	2	E04-ECLS06A0
20	-----	Brake Screw ( M6 x 6 )	2	-----
21	E04-ECLS11A0	Brake Spring	1	E04-ECLS11A0
22	E04-ECLS09A0	Stopper Screw ( M6 )	1	E04-ECLS09A0
23	-----	Screw for Chassis ( M4 x 10 )	4	-----
24	-----	Screw for Shielding Cover ( M3 x 6 )	2	-----
25	-----	Screw for Chassis ( M4 x 20 )	1	-----
26	-----	Screw for Front Cover ( M3 x 8 )	4	-----
27	E06-ECPJ70B0	Chassis (Dub Controller)	1	E06-ECPJ70B0
28	E06-ECPE25C0	Front Panel	1	E06-ECPE25C0
29	E06-ECQR58A0	Protector for Timer PC Board	1	E06-ECQR58A0
30	E06-EHLL25A0	Timer PC Board	1	E06-EHLL25A0
31	E06-ECQR68A0	Hook (Option)	1	E06-ECQR68A0
32	E06-EHLL53A0	Hand Exposure Switch Assembly (Option)	1	E06-EHLL53A0
33	-----	Tapping Screw (Option)	1	-----
34	-----	Screw for Front Panel ( M3 x 8 )	2	-----
35	-----	Wood Screw ( $\varnothing 4.1 \times 20$ )	3	-----
36	E06-ECPJ73B0	Membrane Switch	1	E06-ECPJ73B0
37	E06-EHLL26A0	Horizontal Arm Assembly	1	E06-EHLL26A0
38	E06-EHLL51A0	Main Controller Assembly	1	E06-EHLL51A0
39	E06-EHLL52A0	Sub Controller Assembly	1	E06-EHLL52A0
31~32	-----	Hand Exposure Switch Assembly Kit (Option)	(1)	303RMSW
40	-----	Pass-Thru Plate (Option)	(1)	303PTP

# APPENDIX 3 : CERTIFICATION

FORM FDA 2579 FROM THE DEPARTMENT OF HEALTH AND HUMAN SERVICES MUST BE COMPLETED AND MAILED TO THE RESPECTIVE AGENCIES FOR THIS INSTALLATION TO BE CONSIDERED COMPLETE. ALSO COMPLETE THE WARRANTY CARD AND THE ASSEMBLERS INSTALLATION REPORT AND RETURN TO BELMONT EQUIPMENT CORP.

## REFER TO THE SAMPLE FORM :

FOR FDA USE ONLY	<b>DEPARTMENT OF HEALTH AND HUMAN SERVICES</b> PUBLIC HEALTH SERVICE FOOD AND DRUG ADMINISTRATION <b>REPORT OF ASSEMBLY          OF A DIAGNOSTIC X-RAY SYSTEM</b>	From Approved: OMB No. 0910-0213 Expiration Date: December 31, 1992 See reverse for OMB statement.	
		<b>D XXXXXX</b>	
<b>1. EQUIPMENT LOCATION</b>			
a. NAME OF HOUSPITAL, DOCTOR OR OFFIC WHERE INSTALLED ✓		<b>2. ASSEMBLER INFORMATION</b>	
b. STREET ADDRESS ✓		a. COMPANY NAME ✓	
c. CITY ✓	d. STATE ✓	b. STREET ADDRESS ✓	
e. ZIP CORD ✓	f. TELEPHONE NUMBER ✓	c. CITY ✓	
		d. STATE ✓	
		e. ZIP CORD ✓	
		f. TELEPHONE NUMBER ✓	
<b>3. GENERAL INFORMATION</b>			
a. THIS REPORT IS FOR ASSEMBLY OF CERTIFIED COMPONETS WHICH ARE(Check appropriate box(es))			
<input checked="" type="checkbox"/> NEW ASSEMBLY - FULLY CRTIFIED SYSTEM		<input type="checkbox"/> RE:PLACEMENT COMPONETS IN AN EXISTING SYSTEM	
<input type="checkbox"/> REASSEMBLY - FULLY CRTIFIED SYSTEM		<input type="checkbox"/> AN ADDITION TO AN EXISTING SYSTEM	
<input type="checkbox"/> REASSEMBLY - MIXED SYSTEM (Both certified and uncertified components)			
b. INTENDED USE(S)(Check applicble box(es))			
<input type="checkbox"/> GENERAL PURPOSE RADIOGRAPHY		<input type="checkbox"/> CT HEAD SCANNER	
<input type="checkbox"/> GENERAL PURPOSE FLUOROSCOPY		<input type="checkbox"/> CT WHOLE BODY SCANNER	
<input type="checkbox"/> TOMOGRAPHY (Other than CT)		<input type="checkbox"/> HEAD - NECK (Medical)	
<input type="checkbox"/> ANGIOGRAPY		<input checked="" type="checkbox"/> DENTAL - INTRAORAL	
<input type="checkbox"/> PODIATRY		<input type="checkbox"/> DENTAL - CEPHALOMETRIC	
<input type="checkbox"/> UROLOGY		<input type="checkbox"/> DENTAL PANAMIC	
<input type="checkbox"/> MAMMOGRAPHY		<input type="checkbox"/> RADIATION THERAPY SIMULATOR	
<input type="checkbox"/> CHEST		<input type="checkbox"/> C - ARM FLUOROSCOPIC	
<input type="checkbox"/> CHIROPRACTIC		<input type="checkbox"/> DIGITAL	
<input type="checkbox"/> OTHER (Specify in comments)			
c. THE X-RAY SYSTEM IS (Check one)		d. THE MASTER CONTROL IS IN ROOM	
<input checked="" type="checkbox"/> STATIONARY		Location of Control Box	
<input type="checkbox"/> MOBILE		e. DATE OF ASSEMBLY	
		<input checked="" type="checkbox"/> (mo.) <input checked="" type="checkbox"/> (day) <input checked="" type="checkbox"/> (yr.)	
4. COMPONENT INFORMATION (If additional space is needed for this section use another form, replacing the preprinted number with form Number and complete items 1,4, and 5 only)			
a. THE MASTER CONTROL IS		b. CONTROL MANUFACTURER	
<input checked="" type="checkbox"/> A NEW INSTALLATION		Takara Belmont, USA Inc.	
<input type="checkbox"/> EXISTING (Certified)		b. CONTROL SERIAL NUMBER ✓	
<input type="checkbox"/> EXISTING (Non-certified)		c. SYSTEM MODEL NAME (CT Systems Only)	
c. CONTROL MODEL NUMBER 303-CM, 303-CS			
Complete the following information for the certified components listed below which you installed. For beam limited device, tables and CT gantries the manufacturer and Model number in the indicated spaces. For other certified components, enter in the appropriate block how many of each you installed in this system.			
f. SELECTED COMPONENTS			
BEAM LIMITING DEVICE	MANUFACTURER	MODEL NUMBER	DATE MANUFACTURED
	MANUFACTURER	MODEL NUMBER	DATE MANUFACTURED
TABLES	MANUFACTURER	MODEL NUMBER	DATE MANUFACTURED
	MANUFACTURER	MODEL NUMBER	DATE MANUFACTURED
CT GANTRY	MANUFACTURER	MODEL NUMBER	DATE MANUFACTURED
	MANUFACTURER	MODEL NUMBER	DATE MANUFACTURED
OTHER CERTIFIED COMPONENTS			
f. (Enter number of each installed in appropriate blocks)			
<input checked="" type="checkbox"/> X-RAY CONTROL		<input type="checkbox"/> CRADLE	
<input type="checkbox"/> HIGH VOLTAGE GENERATOR		<input type="checkbox"/> FILM CHANGER	
<input type="checkbox"/> VERTICAL CASSETTE HOLDER		<input type="checkbox"/> IMAGE INTENSIFIER	
<input type="checkbox"/> TUBE HOUSING ASSEMBLY (Medical)		<input type="checkbox"/> SPOT FILM DEVICE	
<input checked="" type="checkbox"/> DENTAL TUBE HEAD		<input type="checkbox"/> OTHER (Specify)	
<b>5. ASSEMBLER CERTIFICATION</b>			
I affirm that all certified components assembled or installed by me for which this report is being made, were adjusted and tested by me according to the instructions provided by the manufacturer(s), were of the type required by the diagnostic x-ray performance standard (21 CFR Part 1020), were not modified to adversely affect performance, and were installed in accordance with provisions of 21 CFR Part 1020. I also affirm that all instruction manuals and other information required by 21 CFR Part 1020 for this assembly have been furnished to the purchaser and within 15 days from the date of assembly, each copy of this report will be distributed as indicated at the bottom of each copy.			
a. PRINTED NAME ✓	b. SIGNATURE ✓	c. DATE ✓	
d. COMMENTS			



**BELMONT EQUIPMENT, Division of Takara Belmont, USA, Inc.**

101 Belmont Drive Somerset, New Jersey 08873 U.S.A. TEL.:(732) 469-5000 / (800) 223-1192 Fax.:(732)526-6322 / (800) 280-7504  
[www.belmontequip.com](http://www.belmontequip.com)

**TAKARA CO, CANADA LTD.**

2076 S. Sheridan Way, Mississauga, Ont., L5J2M4, Can. TEL.:(905) 822-2755 Fax.:(905)822-6203  
[www.takarabelmont.ca](http://www.takarabelmont.ca)