



Barrier Technique

The first choice in the protection of dental equipment should be the use of disposable barrier products. The repeated use of disinfectants on equipment surfaces without the constant removal of the solution residue will eventually cause some damage to equipment surfaces.

Chemical Disinfection

The manufacturer of the disinfectant to be used should be contacted for them to state that the disinfectant will not damage equipment surfaces including upholstery.

Unacceptable Disinfectants

The following chemicals may damage equipment and upholstery:

- * Alcohol based solutions
- * Bleach
- * Phenol/Alcohol combinations
- * Foam spray products

Use with Caution

- * Water based phenolic disinfectants following exactly the instructions for use.

The Belmont Warranty does not cover damage to equipment and upholstery caused by disinfectant solutions.

WARRANTY

Belmont Equipment is warranted by the manufacturer to be free from defective material and workmanship under normal use and service, for a period of two (2) years' from date of shipment to the Buyer, except that any part or parts that are replaced under this Warranty within ninety (90) days of the completion of the two year period shall be warranted to be free from defective material and workmanship for a period of ninety (90) days from date of shipment of said parts to Buyer. Belmont will repair or replace any defective part under this Warranty, provided the part is returned to our factory with prepaid postage, delivery or freight charges. In the event Warranty service must be performed to correct any defect, only Belmont and/or one of its authorized dealers shall provide same upon mutually agreeable arrangements made in advance.

Except as otherwise provided herein, there is NO WARRANTY, representation or condition of ANY KIND, express or implied (including NO WARRANTY OF MERCHANTABILITY OR FITNESS) and none shall be implied by law. THE EXPRESS WARRANTY AND THE REMEDIES CONTAINED HEREIN (1) ARE MADE SOLELY TO THE FIRST PURCHASER FOR BENEFICIAL USE (THE BUYER), (2) ARE THE SOLE WARRANTIES AND REMEDIES, (3) ARE IN LIEU OF ALL OTHER WARRANTIES, GUARANTEES, AGREEMENTS OR OTHER LIABILITIES, WHETHER EXPRESS OR IMPLIED, AND ALL OTHER REMEDIES FOR BREACH OF WARRANTY OR ANY OTHER LIABILITY OF BELMONT. IN NO EVENT SHALL BELMONT BE LIABLE FOR CONSEQUENTIAL OR INCIDENTAL DAMAGES.

No person, agent, distributor or dealer is authorized to change, modify or extend the terms of the Warranty in any manner, whatsoever.

This warranty is void when failure or defect is caused by conditions beyond the manufacturer's control, such as damage resulting from mishandling, neglect, misuse, improper maintenance, accident or alteration or repair by anyone other than Belmont or an authorized Belmont dealer.

Labor required to repair, replace or retrofit is not included during the warranty period by the manufacturer.

PRODUCT DESCRIPTION	4
UNPACKING	5
INSTALLATION AND ASSEMBLY	
Utility Center	6
Panel Template	6
Doctors & Assistants Delivery System	7
CONTROL FUNCTIONS	8
FINAL ADJUSTMENTS 10.....	
Arm Tension Adjustment.....	10
SERVICE AND MAINTENANCE	
Syringe	11
Vacuum	12
TUBING CONNECTIONS 13	
SCHEMATICS	
Model BDS-2541 Automatic Control System Schematic	
PARTS & SERVICE DRAWINGS	
Model BDS-2541 Automatic Control	
Belmont Left/Right Duo Unit Arm System	
Bearing Assembly	

PRODUCT DESCRIPTION

The Belmont Model BDS-2541 Left/Right cabinet or wall mounted Duo Delivery System features an automatic control for three handpieces mounted beneath the work surface, a doctor's 3-way air/water syringe, master on/off, individual handpiece adjustment, non-retraction water coolant with on/off, water coolant adjustment, 4-hole Midwest oblate handpiece tubing, and a wet/dry type foot control.

Assistants instrumentation features a control vacuum package including HVE, SE Valves and 3-way air/water syringe.

The Doctor and Assistants instrument delivery systems are mounted beneath a 17" x 19" work surface which is suspended by counterbalanced flex arm with pneumatic air brake.

PRE-INSTALLATION CHECK

Unpack the shipping carton and check to see that all parts are included and undamaged.

CONTENTS

BDS-2541 or BDS-2543 Unit
Water Bottle System
Floor Utilities
Installation/Operation Manual

TOOLS NEEDED

Set of Hex Wrenches
Snap Ring Pliers
9/16" End Wrench

INSTALLATION AND ASSEMBLY

WALL MOUNT

See Figure 1

MOUNT PLATE ONLY

1. Measure up 23" from the floor to bottom of mounting plate.
2. Remove the vertical mounting plate from box and packaging.
3. Mount plate with bushing centered to studs in wall or, if desired, to cabinet. **Note:** Cabinet should have 3/4" backing.

MOUNT PLATE WITH PANEL

1. Measure up 14" from the floor to bottom of the panel.
2. Remove the vertical mounting plate from box and packaging.
3. Mount plate with bushing centered to the panel.

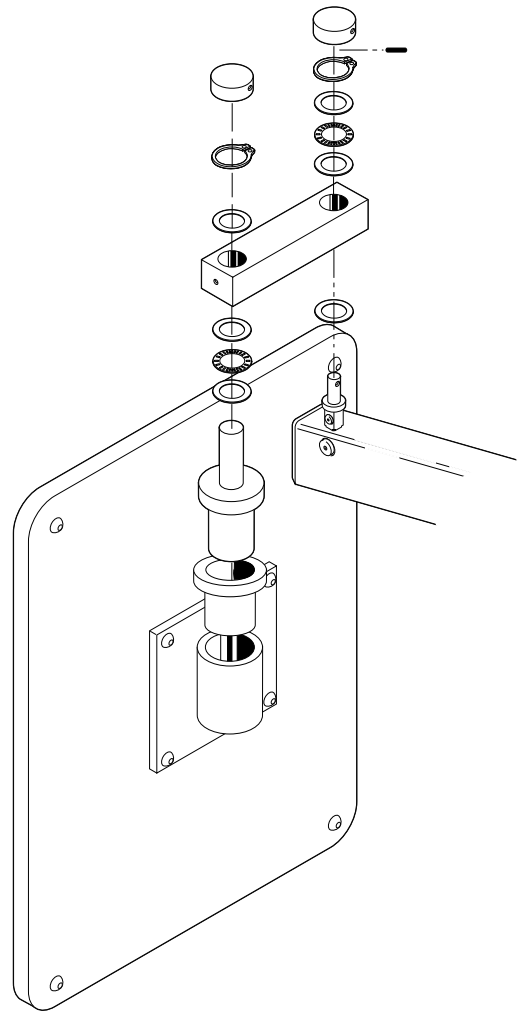

Figure 1. Mount Bearing Stack

FLEX ARM

1. Insert the flex arm knuckle through the hole in the short mounting bar and install using the hardware shown in Figure 1.
2. Check the work surface level and adjust the leveling set screws in the mounting plate as required.

INSTALLATION AND ASSEMBLY

A-5 CABINET MOUNT

INSTALL ARM AND HOLDER SYSTEM

1. Install 4 of the 3/8 -16 "T" nuts from the back side of the pre-drilled mounting panel.
See Figure 2.
2. Mount the delivery system in place, level and tighten mounting screws.
3. Connect the delivery system umbilical tubing to the appropriate barbs in the floor utilities.
4. Connect the foot control tubing to the appropriate barbs in the utility center.

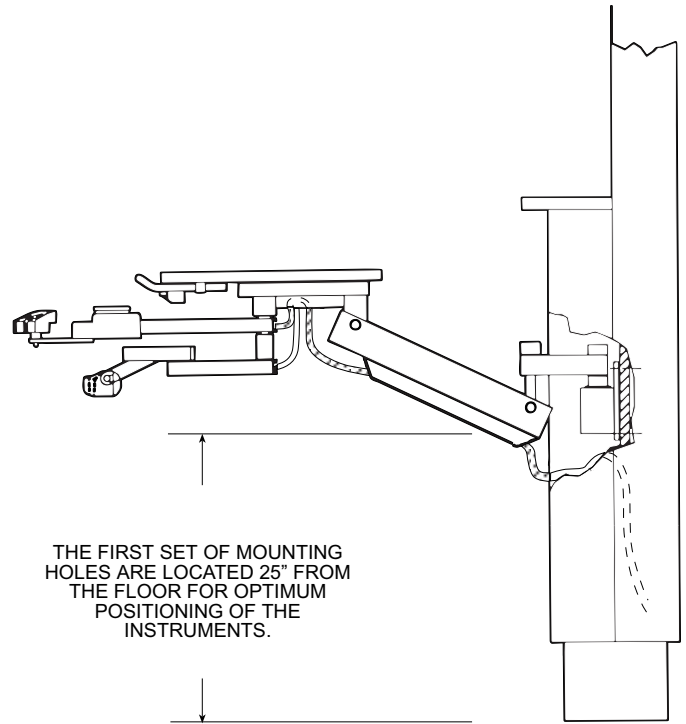

Figure 2. Left/Right Duo System Mounting

CONTROL FUNCTIONS

HANDPIECE CONTROL FUNCTIONS

Handpiece pressure and water coolant flow are located on the control housing beneath the work surface.

DRIVE AIR PRESSURE CONTROL

Allows handpiece to be adjusted to its manufacturer's recommended operating pressure. *Turn the adjusting screw counter clockwise to increase the pressure, clockwise to decrease the pressure.*

DRIVE AIR PRESSURE GAUGE

Indicates drive air pressure to the handpiece.

WATER COOLANT FLOW CONTROL

Allows adjustment to be made to the handpieces. *Turn the knob counter clockwise to increase the flow, clockwise to decrease the flow.*

WATER COOLANT ON/OFF

Located on the foot control. Activates handpiece water coolant system. *Flip the toggle on the foot control to the right to activate the system.*

Figure 4 shows the automatic handpiece holder and syringe holder assembly.

AUTOMATIC HANDPIECE HOLDER

Lifting a handpiece from its holder signals the automatic control system to supply drive air and air/water coolants to the handpiece when the foot control is depressed. When the handpiece is placed back in the holder, a signal to the automatic control system stops the drive air and air/water coolant supply.

FOOT CONTROL

Regulates drive air and air coolant to the active handpiece. *To operate, apply pressure to the foot control for drive air.*

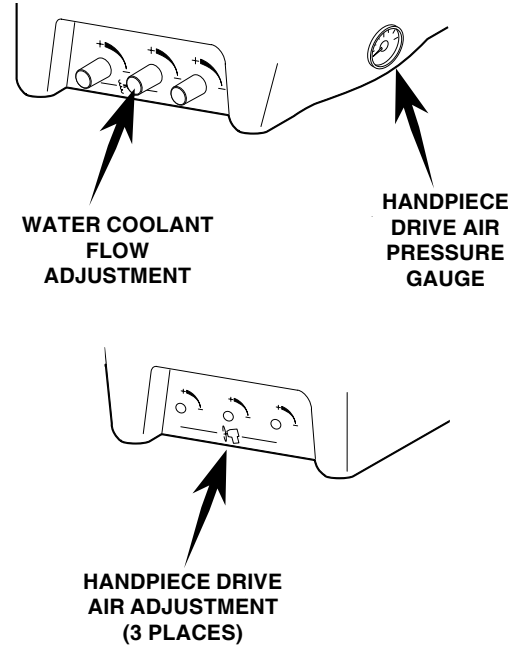

Figure 3. Handpiece control functions.

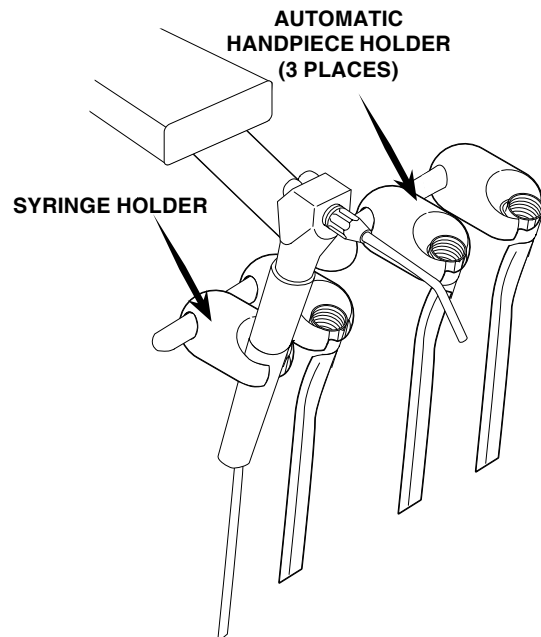

Figure 4. Automatic handpiece holder assembly.

BDS - 2541

DUAL CONTROL FUNCTIONS

Some controls for the system are located underneath the front of the work surface. Figure 5 shows the location and identifies the function of these controls

PNEUMATIC BRAKE ON/OFF

Activates flexible arm brake. *Flip toggle up to apply brake.*

MASTER ON/OFF

Turns on air and water for the complete system. This toggle controls the air actuated master valves in the utility center. *Flip toggle up to activate system. Always turn the toggle OFF whenever unit is not in use.*

WATER FLOW ADJUSTMENT FOR QD

Allows adjustment of water through the quick disconnect. *Turn knob counter clockwise to increase flow, clockwise to decrease flow.*

QUICK DISCONNECT

Connection for additional water source.

FLUSH

Flushes handpiece water lines on all handpieces that are out of their holders. *Flip toggle up to activate, down to turn off flush action.*

AIR COOLANT ADJUSTMENT

Allows adjustment of air coolant to handpiece. *Turn knob counter-clockwise to increase flow, clockwise to decrease flow.*

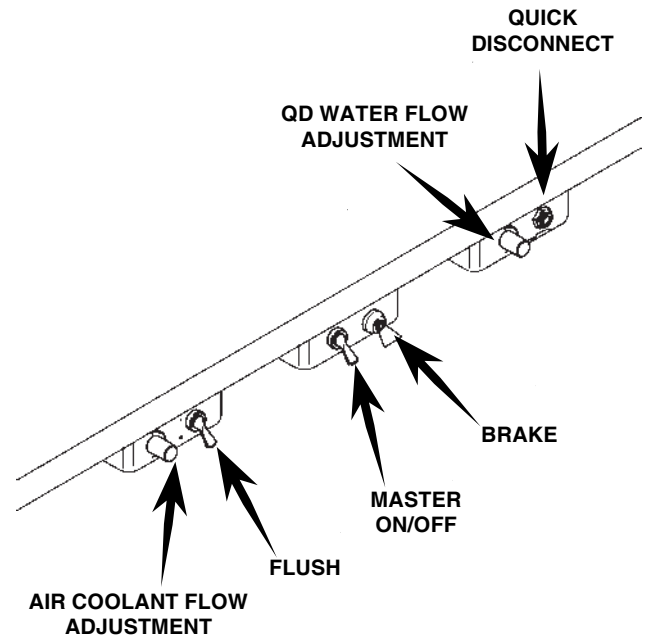

Figure 5. BDS-2541 Control Functions

BDS - 2543

CONTROL FUNCTIONS

The function and location of the BDS-2543 are exactly the same as above except that there is no air coolant adjustment and flush on/off toggle.

FINAL ADJUSTMENTS

FLEX ARM

ADJUSTING THE FLEX ARM TENSION

(See figure 6.)

1. Move the flex arm to the maximum up position.
2. Slide the bottom cover away from the wall mountl end of the arm until the adjusting nut is revealed.
3. Using a flat blade screwdriver, turn the adjusting nut until the desired tension is achieved.

Clockwise - to increase tension.

Counterclockwise - to decrease tension.

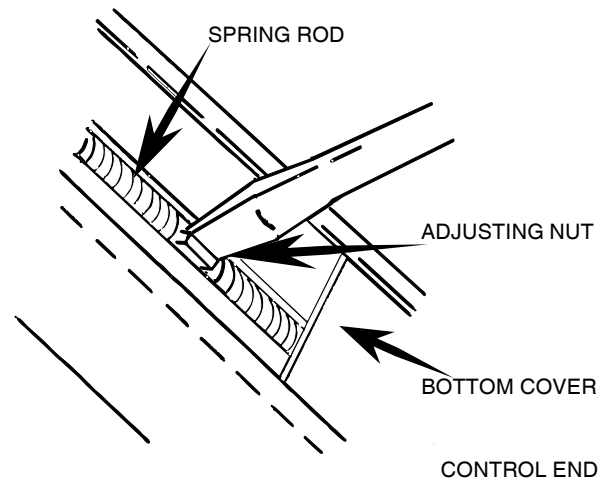

Figure 6. Adjusting the flex arm tension.

FINAL ADJUSTMENTS

Adjust the air and water regulated pressure. Air = 80 psi, Water = 40 psi (The water bottle sytem pressure regulator has been pre-set at the factory to 30 psi.)

Adjust the handpiece pressure.

Adjust the syringe flow, if necessary.

Check for any leaks.

Replace all covers.

SYRINGE

TIP STERILIZATION

1. To remove Syringe Tip, firmly grasp tip and pull away from Syringe head.
2. Replace the tip by inserting a new one into the tip socket, and firmly pushing into place until you feel it softly "pop" into place. To ensure it has been fully inserted, the uppermost small groove on the tip shank must be just visible over the end of the socket. See Figure 7.

NOTE

Be sure to rinse all cleaning agents from the tip prior to sterilization. You may sterilize Syringe Tips by any of the following methods; Chemical Vapor, Ethylene Oxide or Steam Autoclave. Temperatures should never exceed 280 degrees Fahrenheit, (138 degrees Celsius).

INSTALLATION

1. Turn off Air and Water supplies.
2. Unscrew Syringe handle and determine which fitting leads to the air button.
3. Slide the Syringe handle down over the syringe tubing. Select the air side of the syringe tubing and connect to the air fitting on the syringe.
4. Repeat with the water tubing to the water fitting. Ensure that the unit end of the Syringe tubing is properly connected to the air and water supply fittings on the dental unit. Recommended operating pressures : Air 80 psi, Water 40 psi.

This groove must be just visible above tip of conical socket.

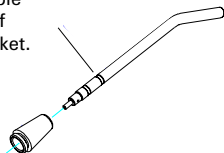

TROUBLE SHOOTING

Problem: Water leakage around buttons.
Solution: Replace the button assembly # C-1701 (See figure 7). Turn water and air supply off. Depress air and water buttons on Syringe to relieve residual pressure. Hold both buttons down and use a paperclip to push cross pin out of syringe head. Gently remove button from head, being careful not to lose conical spring beneath. To install new button, ensure that conical spring is seated with the small end pointing up. Gently push into place and hold both buttons down firmly while re-inserting cross-pin.

Problem: Water spray when air button is pressed.
Solution: Ensure tip is properly and fully inserted. If so, replace O-ring #R-C16004 (See Figure 7). Twist conical tip socket assembly (R-C21600-3) off of syringe head to access this O-ring. When re-installing tip socket assembly, hand tighten only. If tip cannot be fully inserted, then socket is too tight.

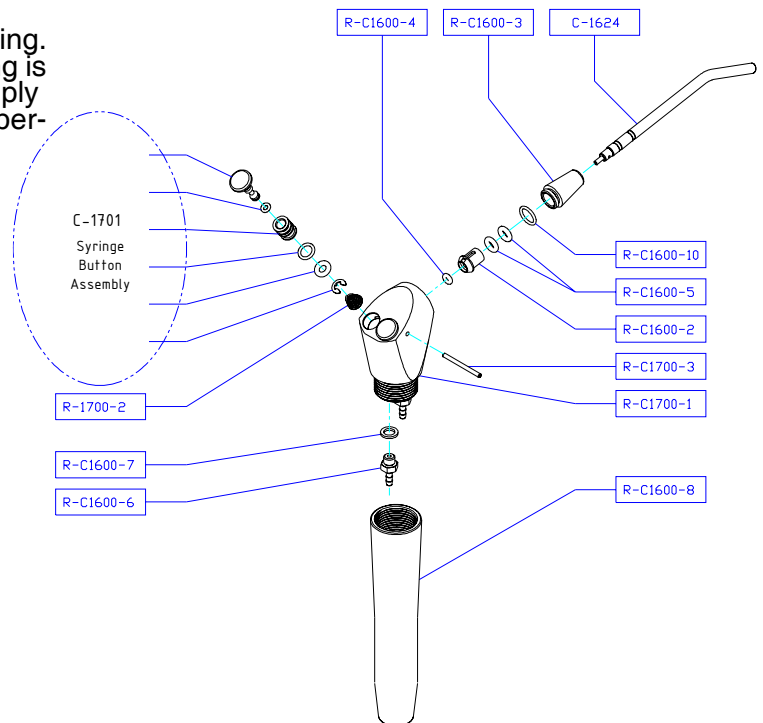

Figure 7. Syringe.

SERVICE AND MAINTENANCE

VACUUM VALVE

PRIOR TO STERILIZATION

Minimize the potential accumulation of debris that could interfere with the operation of the instrument by flushing clean water through it while working the valve lever open and closed several times.

1. Using mild cleaner and water, wipe all surfaces of the valve and dry with a clean, soft cloth.
2. Use a stiff HVE or SE cleaning brush of an appropriate size to dislodge internal buildup.

NOTE

Do not Ultrasonically clean, as instrument surface finishes may be damaged.

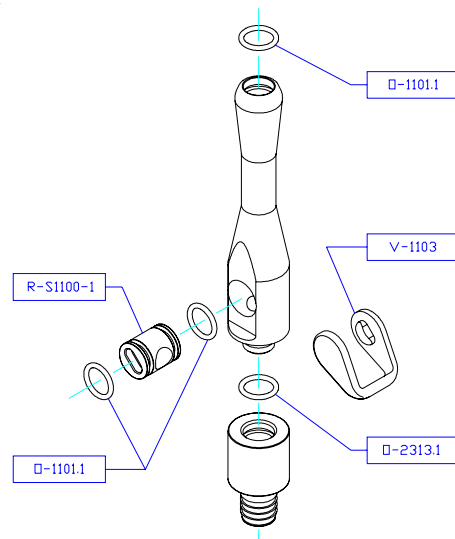

PERIODIC MAINTENANCE

If the operation of the valve becomes sticky or stiff, it may be necessary to remove the valve spool for a thorough cleaning and lubrication. Refer to the appropriate exploded view shown in Figure 8.

1. Gently lift one end of the plastic on/off lever (V-1103 / V-1203) out from the indentation on the end of the spool.
2. Push the spool out of the valve toward that side and completely disengage the lever from the other end.
3. Clean the spool and inspect O-rings and replace those that have nicks, cuts, flat spots or show signs of wear. Lubricate O-rings with O-ring lube then reassemble the valve.

SURFACE DISINFECTION

Bleach or Sodium Hypochlorite solutions may permanently damage the valve. Some surface disinfectants that will not harm the valve are Birex SE, Sporicidin, Coldspor, Procide Spray, Sterall Spray, Asepti-IDC, Biocide, Promedyne, Iodo-Five, Wescodyne, and Cavicide.

METHODS OF STERILIZATION

You may sterilize Belmont Autoclavable Valves by any of the following methods: Chemical Vapor Method, Ethylene Oxide, Steam Autoclave or Dry Heat.

NOTE

Temperature should never exceed 280 degrees Fahrenheit, or 138 degrees Celsius. Do not place the instrument in close proximity to the sterilizer heating element. Avoid contact with the sterilizer walls.

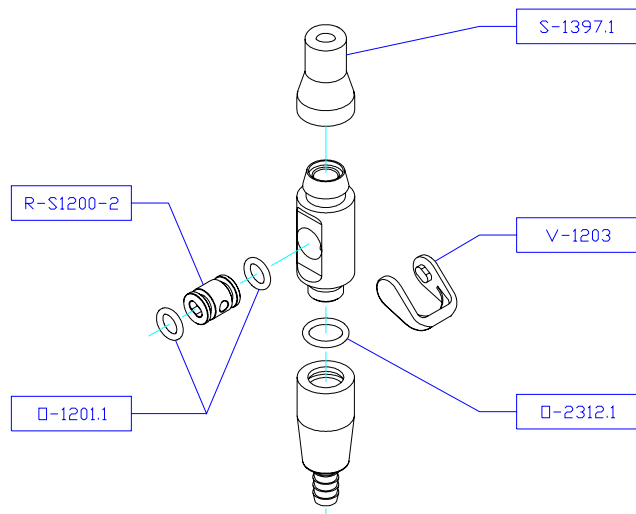
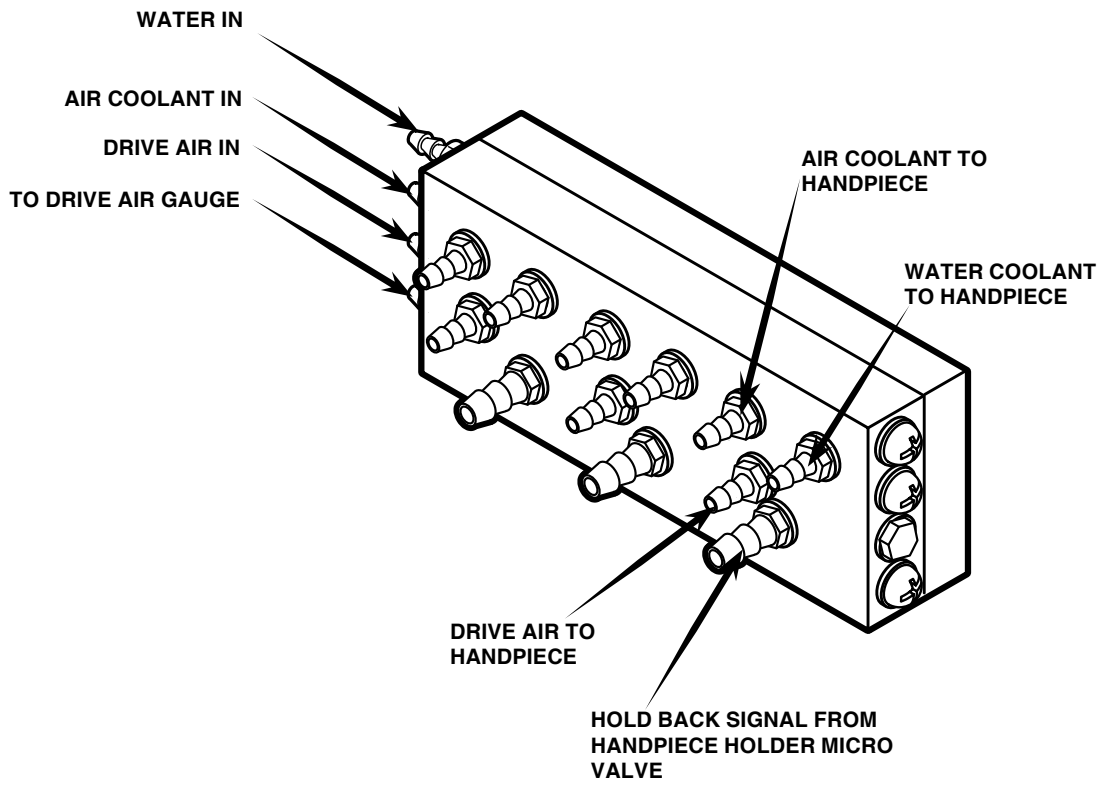

Figure 8. Vacuum Valves.

TUBING CONNECTIONS

BDS-2541 AUTOMATIC CONTROL



AUTOMATIC CONTROL SYSTEM SCHEMATIC MODEL BDS-2541/2543

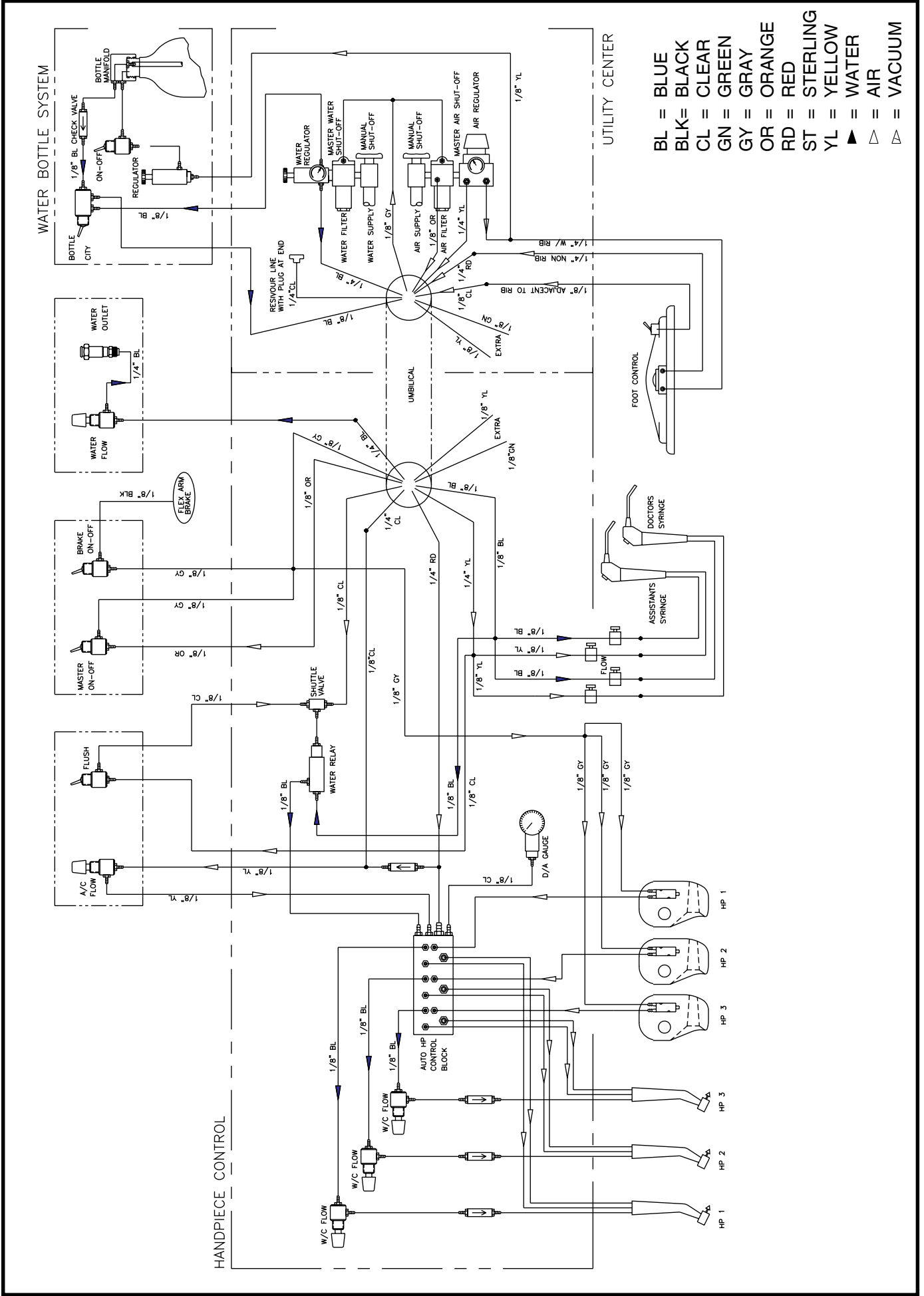

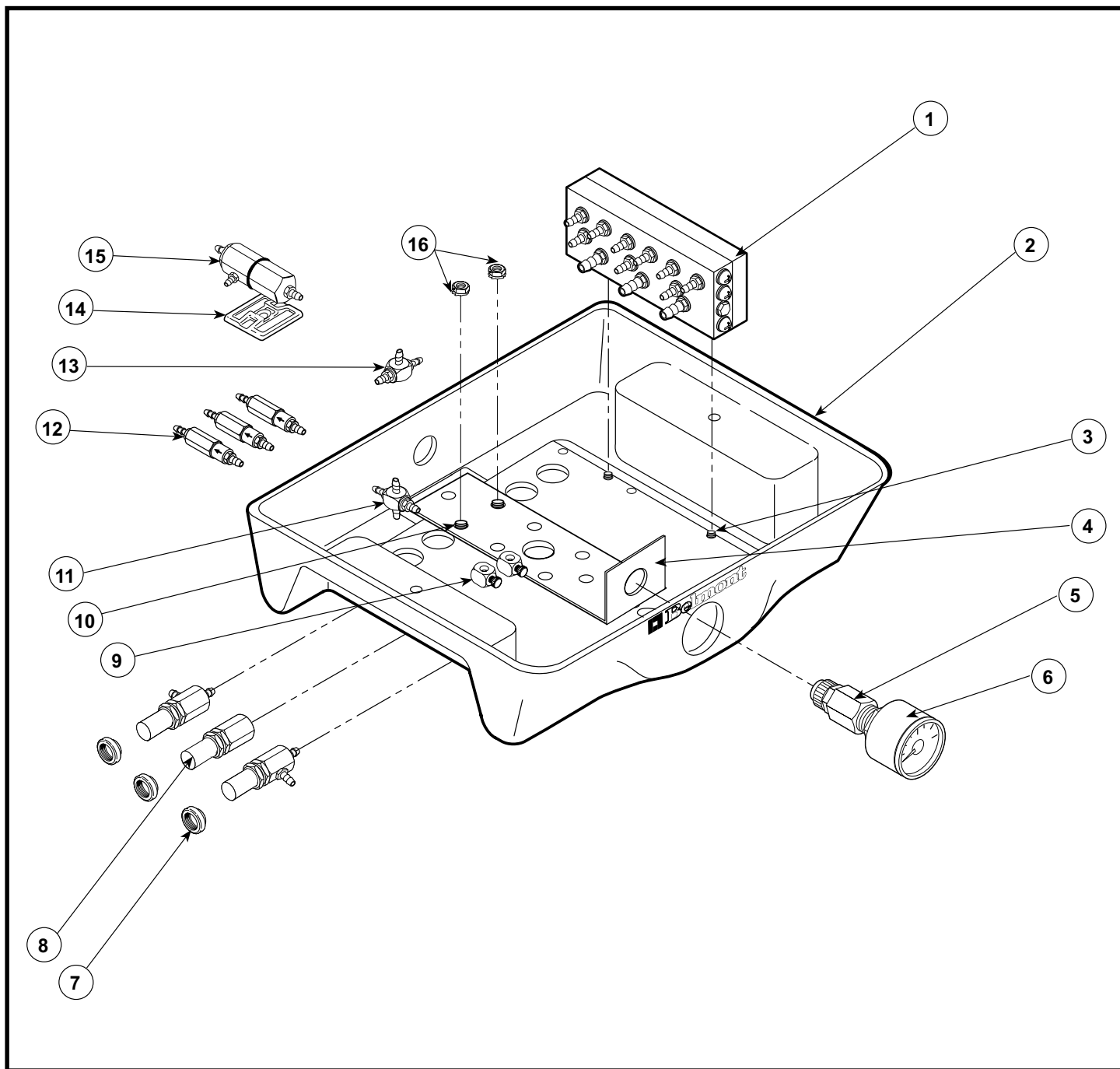

REF. NO.	DESCRIPTION	PART NO.	QTY.
1	AUTOMATIC HANDPIECE CONTROL, TRI-BLOCK .	1100-170	1
2	CONTROL HOUSING, MT	0023-615	1
3	SCREW, 4-40 x 1/4" ALLEN BUTTON HEAD	0012-410	2
4	GAUGE BRACKET CONTROL	0023-529	1
5	FITTING, 1/4" POLY x 1/8" FPT	0016-006	1
6	7/8" DIA. GAUGE	0020-030	1
7	DECORATIVE TRIM NUT, SMOOTH, SILVER	0013-016	3
8	NEEDLE VALVE ASSEMBLY	1100-100-X	3
9	FLOW RESTRICTOR	1100-130	2
10	SCREW, 10-32 x 3/8" SST, BUTTON HEAD	0012-136	2
11	FITTING, 10-32, 4-WAY CROSS, FEMALE	0016-060	3
12	CHECK VALVE	1100-105	3
13	SHUTTLE VALVE	1100-140	1
14	RETAINER	0019-039	1
15	WATER PILOT VALVE, 2 WAY, W/O EXHAUST,	1100-145	1
16	NUT, 10-32, KEP, ZINC	0013-008	2

NO.	EXTRA PARTS NOT SHOWN IN DRAWING DESCRIPTION	PART NO.	QTY.
17	10-32 x 1/8", LARGE BARB	0016-001	2
18	10-32 x 1/8", LARGE BARB	0016-002	11
19	1/8 I.D. SLEEVE (SMALL FERRULE)	0016-003	36
20	1/4 I.D. SLEEVE (LARGE FERRULE)	0016-004	3
21	BARB, TEE, 1/16, PLASTIC	0016-055	3
22	BARB, CONNECTOR, 1/16 x 1/16, BRASS	0016-058	1
23	PLASTIC WASHER FOR 10-32	0016-066	2
24	ADJUSTABLE TIE, 4"	0016-067	5
25	BARB, REDUCING, 1/8" TO 1/16"	0016-108	1
26	INTERCONNECT TUBING, 1/8" O.D., YELLOW	0017-201	6 FT
27	INTERCONNECT TUBING, 1/8" O.D., BLUE	0017-401	6 FT
28	INTERCONNECT TUBING, 1/8" O.D., CLEAR	0017-601	7 FT
29	INTERCONNECT TUBING, 1/4" O.D., CLEAR	0017-690	.2FT
30	INTERCONNECT TUBING, 1/8" O.D., GRAY	0017-701	3 FT
31	TUBING, SYRINGE	0017-735	15 FT
32	PLASTIC KNOB, STYLE II, GRAY	0010-202	3

REF. NO.	DESCRIPTION	PART NO.	QTY.
1	TOP	0023-617	1
2	SET SCREW	0012-025	2
3	BASE PLATE	1110-754	1
4	SCREW, 10 x 3/4	0012-105	16
5	SCREW, 6-32 x 3/4	0012-620	4
6	SUPPORT ARM	1110-403	1
7	RISER	1110-281	1
8	COVER	1110-098	1
9	FLEX ARM	1110-094	1
10	UMBILICAL CHANNEL	0023-681	1
11	SCREW, 10-32 x 3/8	0012-136	2
12	SCREW, 3/8-16 x 1.5 BTTN HD	0012-357	3
13	PIVOT BUSHING	0006-037	1
14	LINK PIVOT	0023-606	1
15	PLASTIC WASHER	0011-013	8
16	VACUUM ARM PIVOT	0023-666	1
17	SCREW, 6-32 x 3/8	0012-615	4
18	CONNECTOR	0016-253	1
19	LOCKING CV CANISTER	1400-133	1
20	VACUUM ARM COVER	0023-255	1
21	NYLOCK NUT	6013-010	1
22	ASSISTANCE HOLDER, BELMONT	FASA85A0	1
23	SET SCREW, 6-32 x 1/4	0012-605	1
24	ARM	1110-793	1
25	WASHER, PLASTIC 1" DIA.	0011-016	5
26	PLASTIC WASHER	0011-027	1
27	SCREW, 1/4-20 x 1-1/2	0012-263	1
28	VACUUM PLATE	0023-256	1
29	SCREW, 6-32 x 3/8	0012-013	2

REF. NO.	DESCRIPTION	PART NO.	QTY.
30	PIVOT BUSHING	0006-020	5
31	NYLON NUT, 3/8-16	6013-012	2
32	HUB	0023-604	1
33	PIVOT ARM, DOCTORS	0023-667	1
34	HOLDER BAR	0024-098	1
35	SYRINGE HOLDER	FGTA12A0	2
36	AUTO HOLDER	FGTA11A0	3
37	SCREW, 1/4-20 x 3/4	0012-273	1
38	EXTENSION, PIVOT HOLDEER BAR	0023-668	1
39	SET SCREW, 3/8-16 x 1 1/4	0012-383	1
40	SET SCREW, 10-32 x 5/16	0012-128	2
41	HUB	0023-603	1
42	SCREW, 10-32 x 5/8	0012-134	8
43	SCREW, 10 x 1-1/4	0012-122	4
44	QUICK DISCONNECT	0016-042	1
45	NEEDLE VALVE	1100-100-Z	2
46	KNOB	0010-202	2
47	TRIM NUT	0013-016	5
48	TOGGLE VALVE	1100-401-x	3
49	HANDLE BAR	0024-101	1
50	HOLDER BAR BRACKET	0023-390	2
51	A/C & FLUSH BRACKET	0023-614	1
52	MASTER/BRAKE BRACKET	0023-613	1
53	WATER BRACKET	0023-285	1
54	SCREW, 6-32 x 3/8	0012-615	1
55	UMBILICAL HOLDER BRACKET	0023-670	1

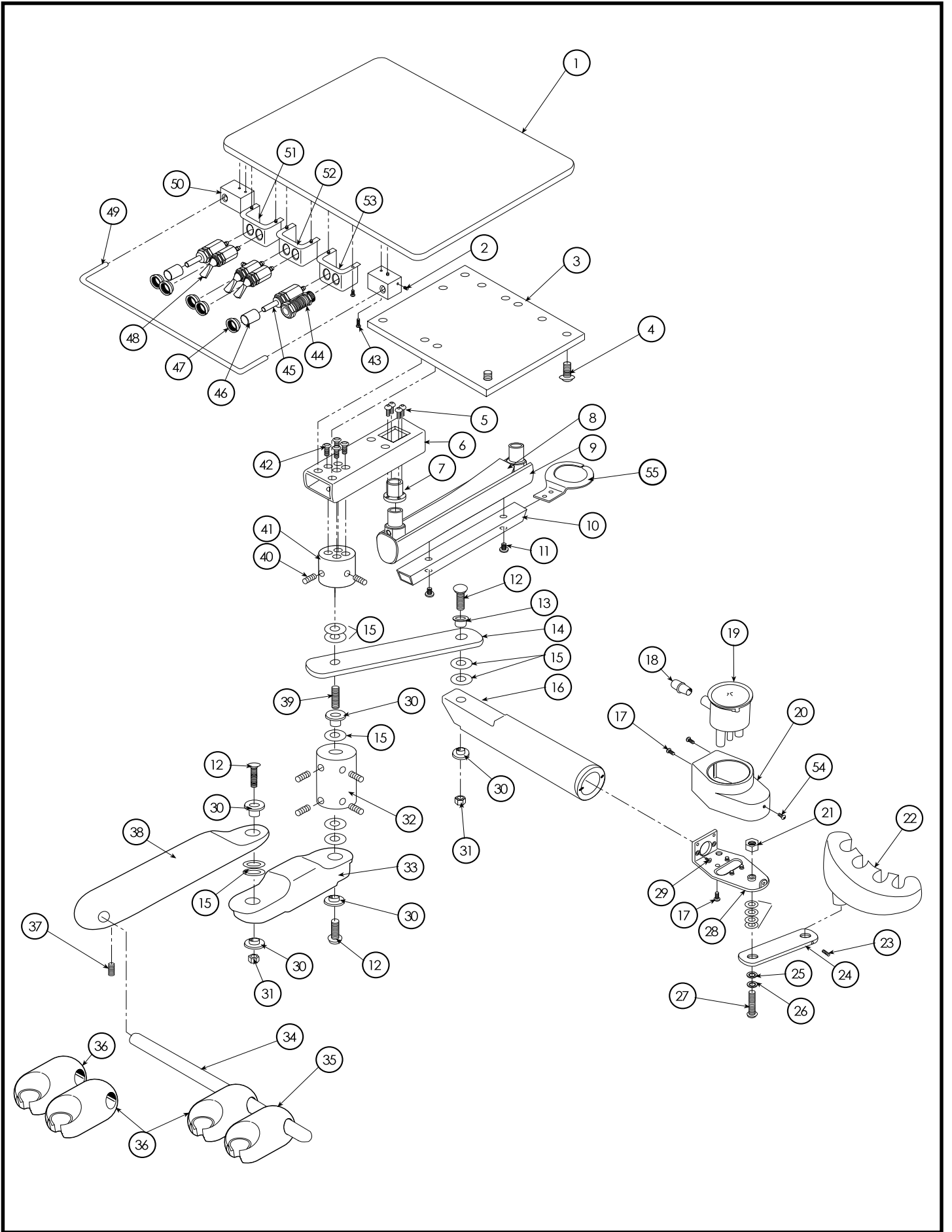

**BELMONT LEFT/RIGHT DUO UNIT
ARM SYSTEM**

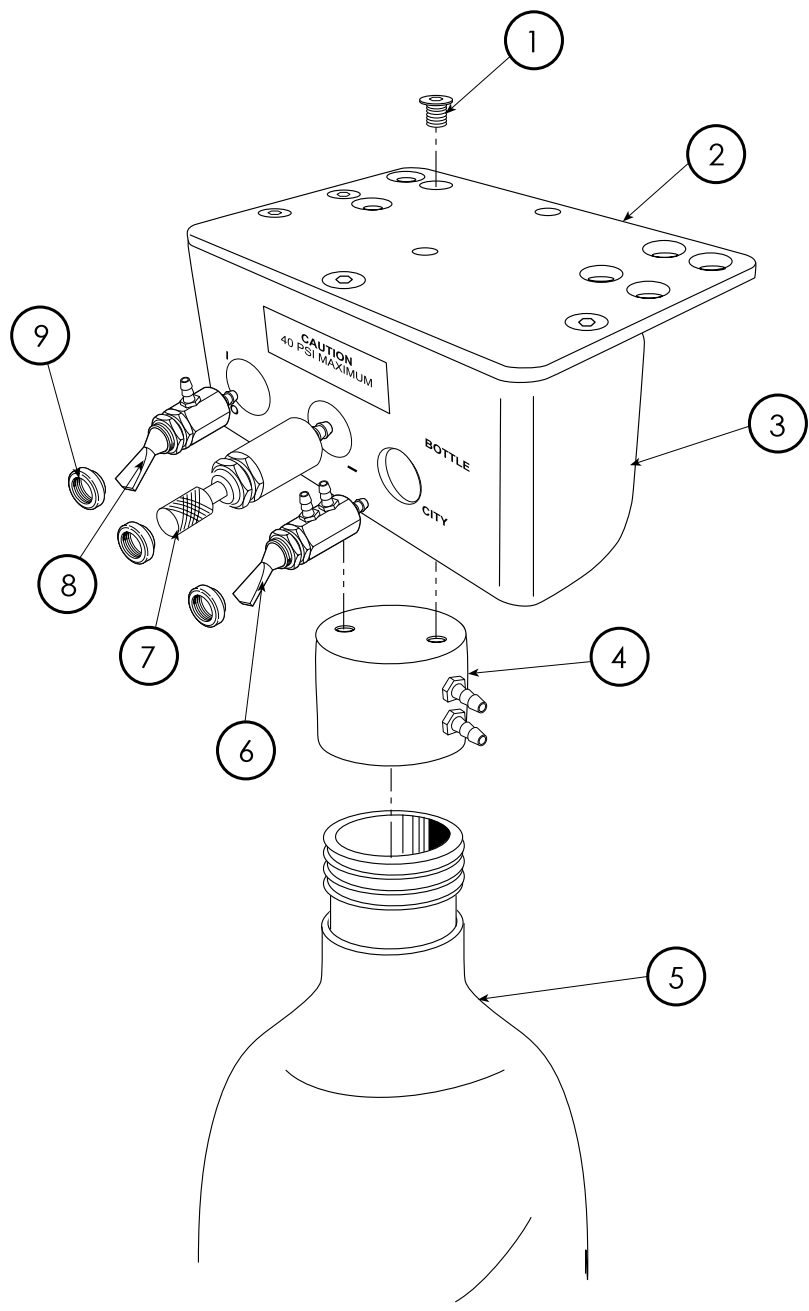

REF. NO.	DESCRIPTION	PART NO.	QTY.
1	SCREW, 10-32 x 3/8 FLAT HEAD	0012-137	5
2	BRACKET	0023-244	1
3	ADAPTER PLATE	0023-247	1
4	PRESSURE HEAD ASSEMBLY	1100-281	1
5	BOTTLE, 1 LITER	0010-364	1
6	ROUTING VALVE	1100-404-F	1
7	REGULATOR	0020-029	1
8	ON/OFF TOGGLE SWITCH	1100-403-F	1
9	TRIM NUT	0013-016	3

SINGLE WATER BOTTLE SYSTEM
1700-116

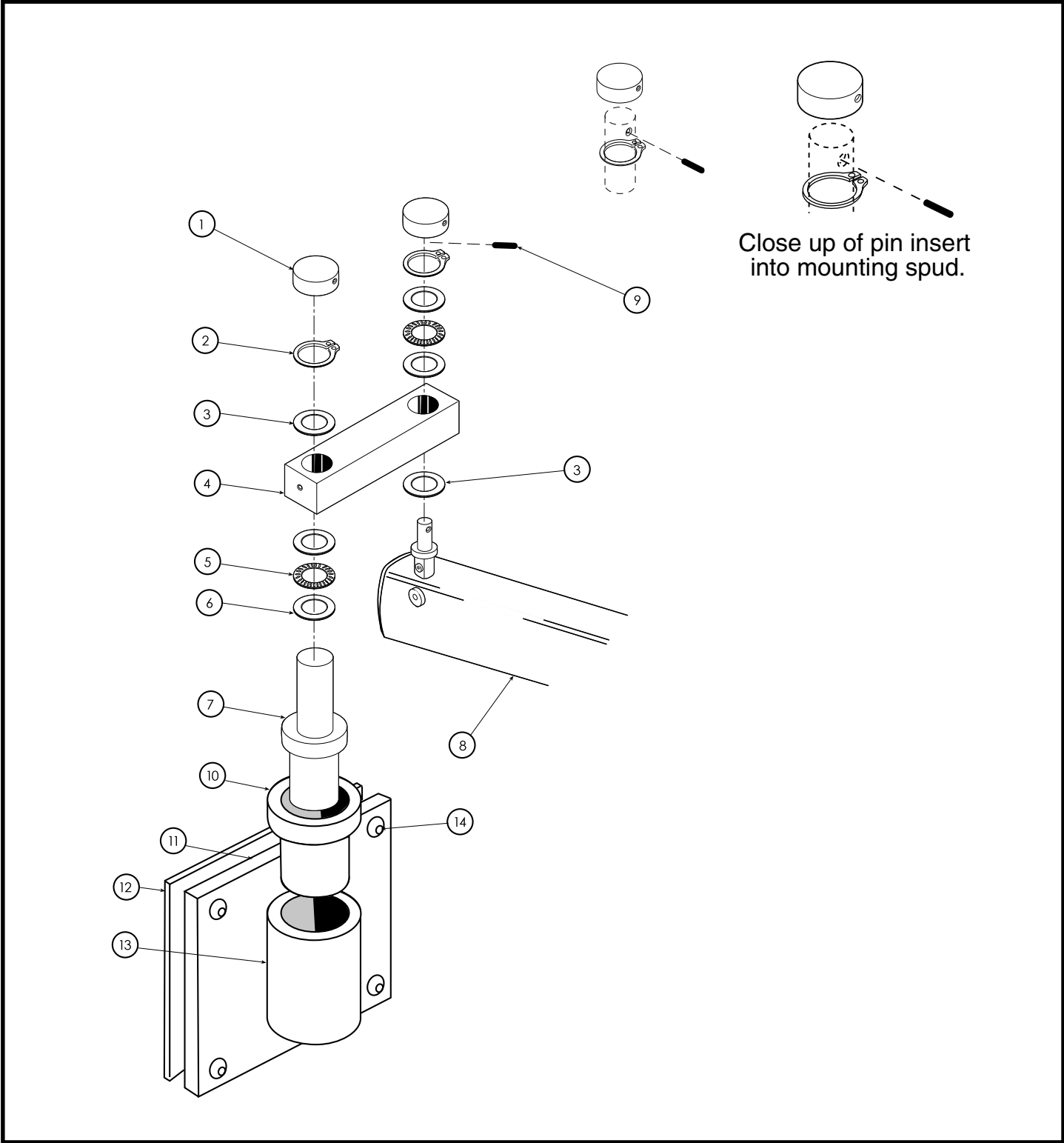

REF. NO.	DESCRIPTION	PART NO.	QTY.
1	CAP/KNUCKLE, MODEL 1150	1110-433	2
2	SNAP RING	0019-061	2
3	WASHER	0011-029	2
4	BAR, MOUNTING	1110-413	1
5	THRUST BEARING	3110-010	2
6	THRUST WASHER	3110-011	4
7	1160/1155 WALL ADAPTOR PIVOT	1116-160	1
8	FLEX ARM ASSEMBLY 15"	1110-094	1
9	PIN, DOWEL 1/4 X 1	0019-019	1

REF. NO.	DESCRIPTION	PART NO.	QTY.
10	ARM BUSHING	1110-506	1
11	MOUNTING PLATE	1110-508	1
12	LEVELING PLATE	1110-509	1
13	HUB, WALL MOUNT	1110-969	1
14	SCREW, 3/8-16x1-1/4 BM	0012-380	4