

I 0 2 - 1 1 6 7 E

Installation Manual

Digital Panoramic Radiograph
Bel-Cypher N

Notice

★ Read this installation Manual thoroughly before Installation.

The classification is shown as follows

- According to the type of protection against electric shock. : Class I
According to the degree of protection against electric shock. : Type B applied part

TAKARA BELMONT CORPORATION.



Caution!

This manual provides information and instruction for the installation, assembly, and certification procedures for the “Bel-Cypher N” X-Ray.

The instructions contained in this book should be thoroughly read and understood before attempting to install the “Bel-Cypher N” unit. After the installation is completed, file this manual and refer back to it when performing periodic maintenance.

CONTENTS

1. Introduction	01	1 / 1
2. WARNING	02	1 / 2
3. Pre-Installation Instructions	03	1 / 1
4. Specification	04	1 / 1
5. Names of each components, Measurement of equipment	05	1 / 3
6. Checking of each components and accessories	06	1 / 3
7. Installation Procedure	07	1 /15
8. Methods to install LAN Board for Panoramic Radiography	08	1 / 3
9. Methods to install a TWAIN driver in imaging software	09	1 / 1
10. Post-Installation Instructions	10	1 / 5
11. Contact Information	11	1 / 1
12. Revised record of this manual	12	1 / 1

1. Introduction

1. Observe “Warning” and “Prohibition” matters in this Installation Manual.
2. Read this Installation Manual thoroughly to prevent an accident or trouble.
3. If you have any unclear matters in installation, reconfirm it by reading this Installation Manual.
4. After installation, read Operation Manual to understand operation procedures.
5. Discharge
Be sure to observe Installation Manual. If accidents or troubles of the equipment happen due to improper installation, we cannot be responsible for those accidents or troubles.
6. Repair and repair parts supply
Repair and repair parts supply is available for 10 years from discontinued date.
7.  mark means “ Attention, consult accompanying documents “.

2. WARNING



WARNING

Always conform to the safety work standards to assure safety for workers and other people concerned. Repair work for internal parts of the equipment involves high risk. This should be strictly conducted by an authorized service personnel only.



Meanings



DANGER

Explains danger that may cause serious adverse effect to a human body.



WARNING

Explains an instruction where personal injury or physical damage may occur



CAUTION

Explains an instruction that should be observed for safety reasons



NOTE

States descriptions which serve to improve work efficiency and to help user to understand instructions in the manual



DANGER

This equipment is electrical instrument. Do not splash water.
Such action causes electric shock or trouble of equipment.



WARNING

This X-ray Unit may be dangerous to patient and operator unless safe exposure factors and operating instructions are observed.

This equipment should be installed in the X-ray room surrounded by walls of which lead equivalent are over 1.0mmPb.

The floor should have strength of $650\text{N}/100\text{cm}^2$ and should be rigid.

This equipment has units which are more than 20kg. Heavy units should be brought up by more than 2 people.

Do not put things in area where equipment functions.

In order to avoid influence by other electric equipment, use separated power source from the other electric equipment.

Those who install X-ray apparatus should wear X-ray protector apron.

Pay attention when Sliding Unit is moves up and down.

LASER RADIATION, DO NOT STARE INTO A BEAM, CLASS 2 LASER PRODUCT

1. Laser Beam is applied. For safety, instruct patient not to look at the laser beam.
2. Before the beam is lightened, lower Frankfort Line Beam to bottom.
3. Do not set the beam to patient's eyes.



CAUTION

Do not turn ROTATION ARM by hand. It might cause a trouble of the equipment.

3. Pre-Installation Instructions

1. Manuals

- 1) Installation Manual of Bel-Cypher N
- 2) Operation Manual of Bel-Cypher N

2. Measuring instruments and tools

2-1. Measuring instruments

- 1) Digital Multi Meter with an accuracy of 1%, capable of measuring 150VAC and 20mA DC, and capable of indicating true RMS value within one second
- 2) Fluorescent Screen

2-2. Tools

- 1) Philips Head Screwdrivers (Small and Big)
- 2) Slotted Head Screwdrivers (Small, Anti-Static type)
- 3) Nut Drivers (M6, M5, M4 and M3)
- 4) Ratchet wrench
- 5) Allen keys
- 6) Cutting Nippers
- 7) Long nose nippers
- 8) Hammer
- 9) Electric Drill
- 10) Drill bit 8.3mm = 21/64"(which can drill in wall and a floor)

2-3. Others

- 1) Ethanol for disinfections
- 2) Waste Clothe
- 3) Cleanser

3. User supplied Network Card (NIC) and PC.

NOTE: IN GENERAL, MAJOR STRUCTURAL MODIFICATIONS ARE NOT REQUIRED, HOWEVER THE FLOOR ON WHICH Bel-Cypher N IS PLACED SHOULD BE ABLE TO SUPPORT 600 lbs. DEAD LOAD.

3 Electrical Requirements

1) Power Supply

Bel-Cypher N X-Ray operates on a power supply of 120 VAC. A three wire GROUNDED circuit, separately connected to the central distribution panel with an over current protection device rated for 15 amperes. Recommended wire size is 12 AWG. But if the wire run distance is to exceed 50 feet, 10 AWG is required. For wire run distance in excess of 75 feet, up to 125 feet, 8 AWG is required.

- 2) All connections, workmanship and materials used must comply with the national Electric Code and local codes.

4. Specifications

General name	Digital Panoramic Radiograph
Model	Bel-Cypher N
Power Voltage	120Vac 60Hz 1φ
Power Capacity	11A
High Tension Generator	High Tension Generator (100kHz)
X-ray Tube Voltage	60kV to 80kV (1kV step)
X-ray Tube Current	2 to 8mA (2mA step)
Exposure method	Manual
X-ray Tube	D-052SB (Toshiba)
X-ray Tube Focal Spot	0.5 mm
Total Filtration	2.8mmAl (minimum)
Radiographic Mode	Panorama: (Adult, Child), Panoramic Bitewing (Adult, Child) TMJ:
Exposure Time	Panorama: 10 sec. Panoramic Bitewing:4.6 sec. TMJ: 2.5 sec. (x 4)
Magnification Ratio	Panorama: 1.2 to 1.3, Panoramic Bitewing: 1.2 to 1.3 TMJ: 1.2
Image receiver	Digital Sensor
Beam for patient positioning	3 beams
Dimension	W:920mm x D:1,100mm x H:2,200mm
Weight	Approximately 287 lb(130 kg)

Environmental condition for Operation

Temperature : 41~95F (5~35°C)

Humidity : 30~85%

Pressure : 700~1060 hpa

Environmental condition for Storage

Temperature : 14~140F (-10~60°C)

Humidity : 10~95%

Pressure : 700~1060 hpa

Environmental condition for Transportation

Temperature : 14~140F (-10~60°C)

Humidity : 10~95%

Pressure : 700~1060 hpa

5. Name of each parts and Dimension of equipment

1. Names of each parts of equipment

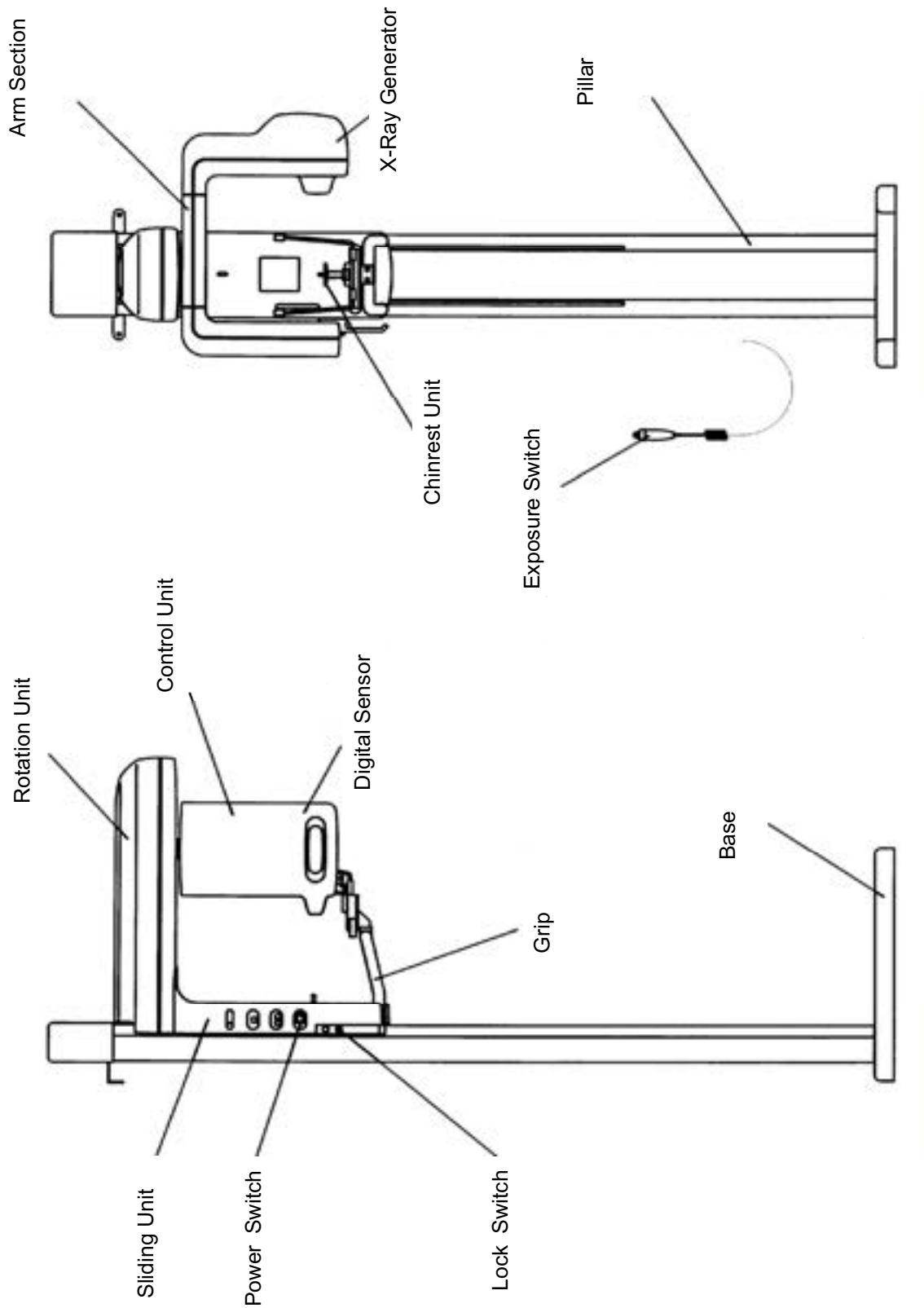

2. Dimensions of equipment (with Free Standing Base)

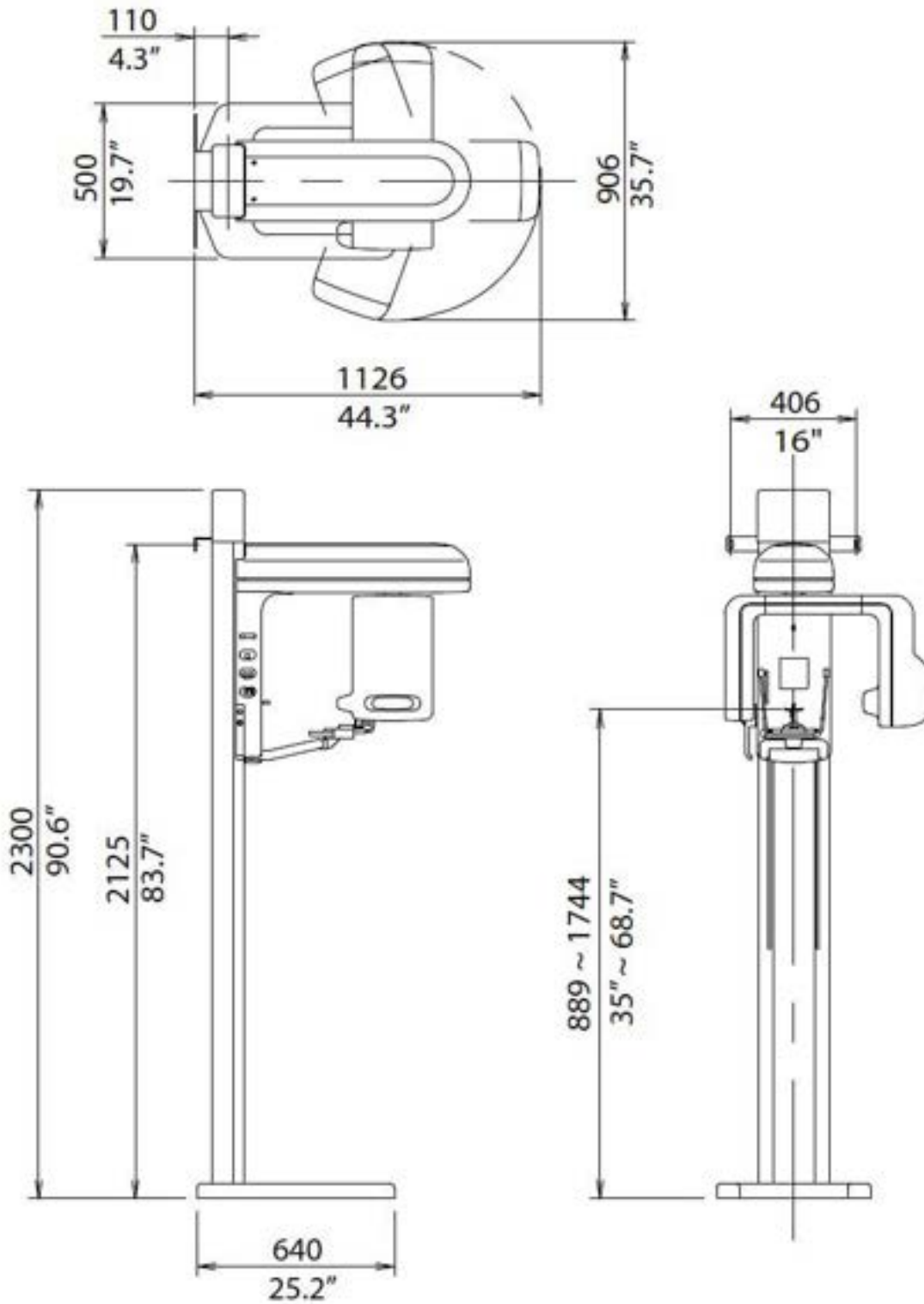

Dimensions of equipment (without Free Standing Base)

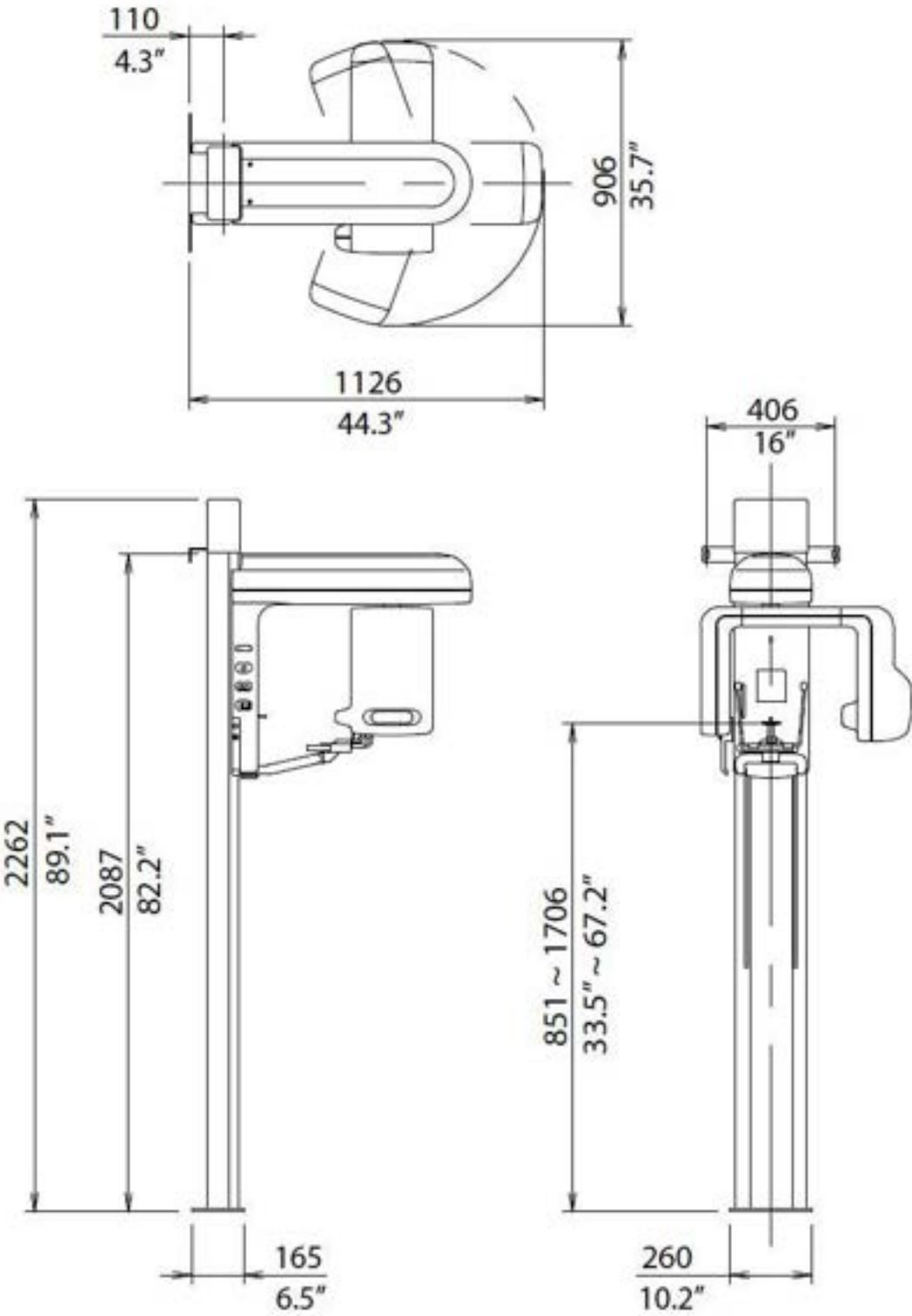

6. Parts and Accessories for equipment

1. Parts for equipment

- 1) Base
- 2) Joint Block
- 3) Pillar
- 4) Rotation Unit ASSY
- 5) Rest Unit Assy
- 6) Weight Assy
- 7) Look pulley Assy
- 8) Upper Cover for Pillar
- 9) Rotation Unit Cover
- 10) Sliding Unit Cover
- 11) Fixed Screw of base and joint block
Cap Screw: M10 x 30 (6 pcs.), Spring Washer: ϕ 10 (6 pcs.), Flat Washer: ϕ 10 (4 pcs.)
- 12) Fixing screws for Joint Block and Pillar
Cap Screw: M6 x 16 (4 pcs.), Spring Washer: ϕ 6 (4 pcs.), Flat Washer: ϕ 6(4 pcs.)
Hexagon socket flat screw: M6 x 16 (4 pcs.), Washer (4 pcs.)
- 13) Fixing bolts for Sliding Unit ASSY and Rotation Unit ASSY
Hexagon Bolt: M8 x 30 (4 pcs.), Flat Washer: ϕ 8 (4 pcs.), Spring Washer: ϕ 8 (4 pcs.)
Taper Pin: (2 pcs.)
- 14) Fixing Bolts for Sliding Unit ASSY and REST ASSY
Hexagon Bolt: M5 x 30 (4 pcs.), Flat Washer: ϕ 5 (4 pcs.), Spring Washer: ϕ 5 (4 pcs.)
- 15) Fixing Screws fro Pillar and Look pulley Assy: Hex-head tapping screw ϕ 4 x 20 (2 pcs.)
- 16) Fixing Screws fro Rotation Unit Cover
Binder Screw: M3 x 8 (2 pcs.), Nylon Washer: ϕ 3 (2 pcs.)
- 17) Fixing Screws for Sliding Unit ASSY
Binder Screw: M3 x 16 (4 pcs.), Nylon Washer: ϕ 3 (4 pcs.)
- 18) Power Cable

Accessories

2-1. Accessories

1) Head Holding Rods (Panorama)

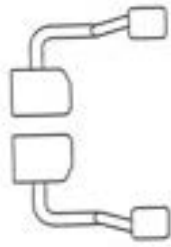

2) Chinrest (Panorama)

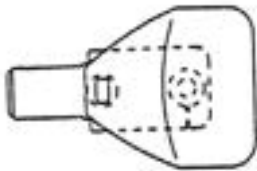

3) Bite Block (Panorama)



4) Ear Rods (TMJ / 4 divisions)



2-2. Expendable Supplies

Bite Block Cover

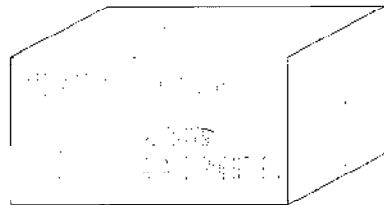

3. X-ray Exposure Switch (with Holder)

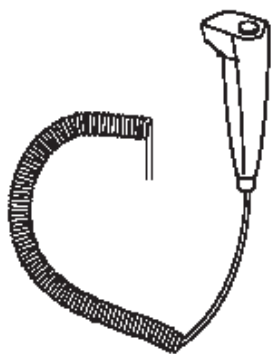

4. CD containing TWAIN Driver

7. Installation Procedure

1. Remove packing material cover for Pillar, then remove pillows shown in below drawing they are used for pillars at installation.

1. 1. (Two pillows)

Put vinyl in the packing or waste clothe on the pillow for protecting scratch of Pillar. Then, put the Pillar on the pillows(Sliding Unit ASSY is down side).

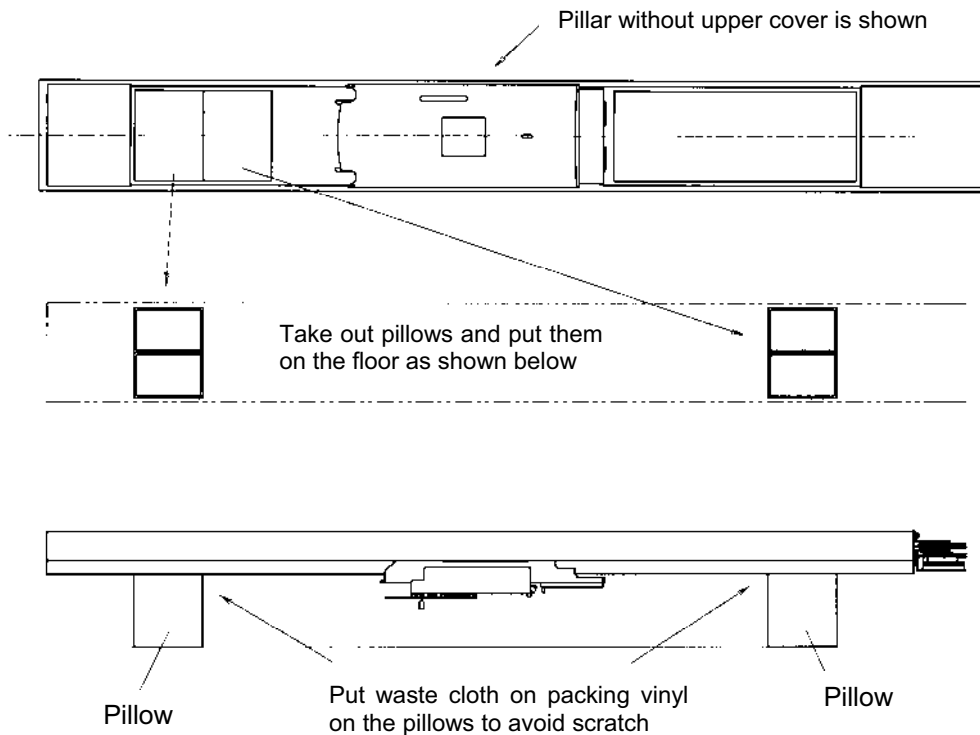

2. Remove pillar cover from Pillar Assy

- (1): Bind M3 × 6 2 sets
(2): Nylon washer φ3 2 sets

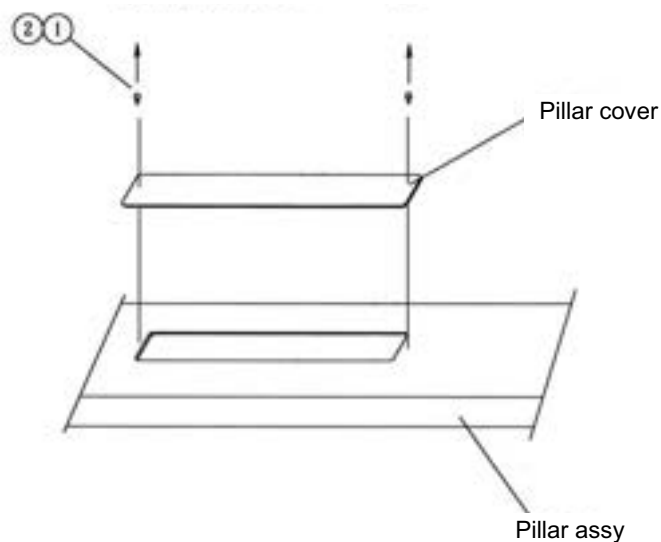

3. Mount joint block by Cap Screws to base.

(1): Cap Screw M10 X 30 6 sets.
(2): Spring ϕ 10 6 sets.
(3): Washer m 10 6 sets

(1): Flat head screw M10 X 25 6

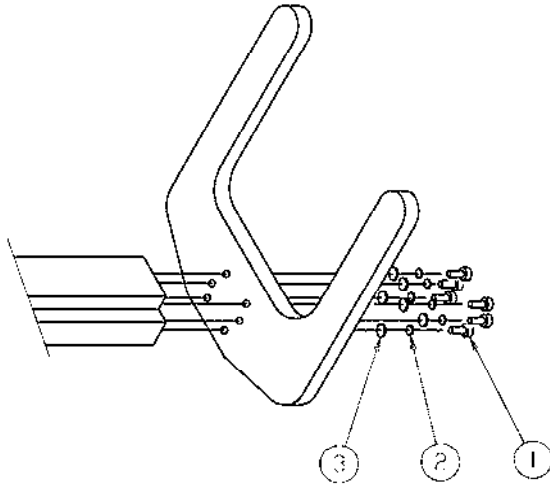

Free Standing Base Type

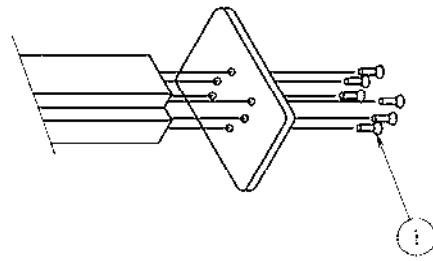

Floor Type

4. Attach the Wall Bracket to upper part of the Pillar by 2 flat head cap screws

(1): cap screw M6 x 12 2 sets

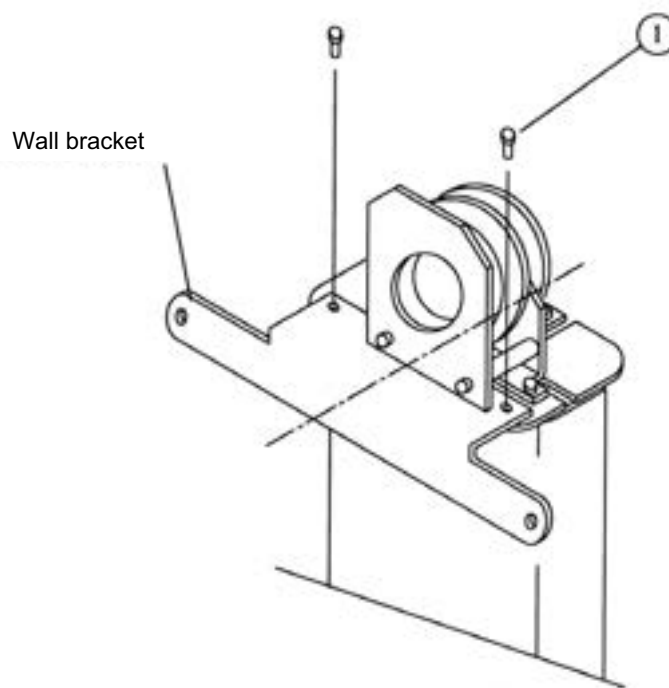

5. Pull out the Steel Rod by removing a nylon washer and a nut, move Sliding Unit up, then insert the Steel Rod to lower hole.

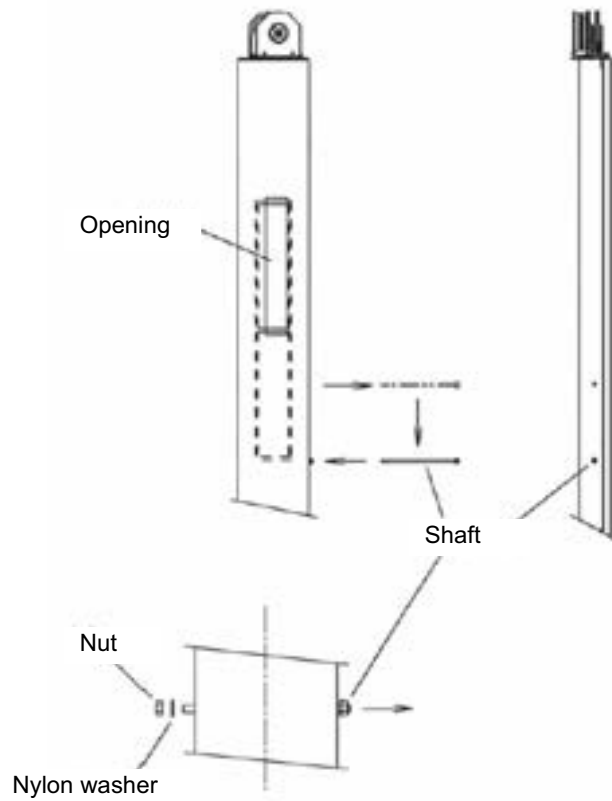

6. Lift Sliding Unit, set 2 counter weight and adjusting weight(s) in upper counter weight frame, then attach the cover.

(1): Screw M4 × 10 2 sets

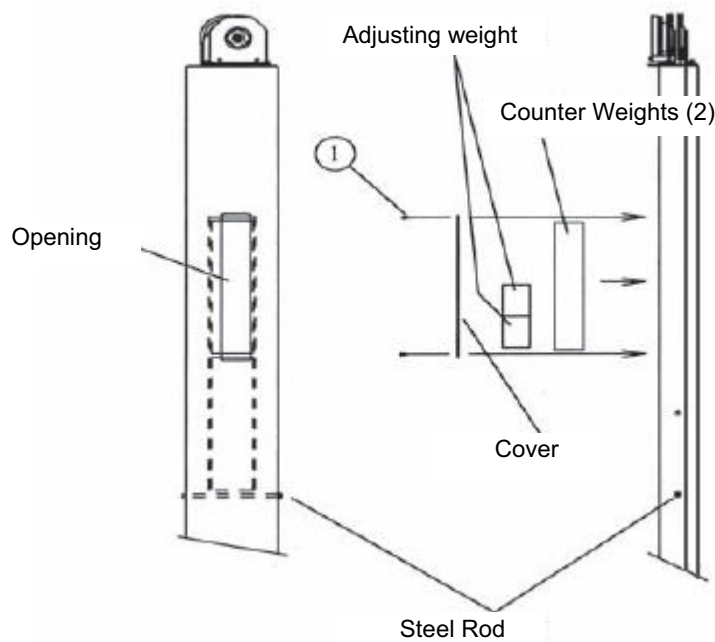

7. Lower Sliding Unit, set 2 counter weight in lower counter weight frame, then attach the cover.

Screw M4 × 10 2 sets

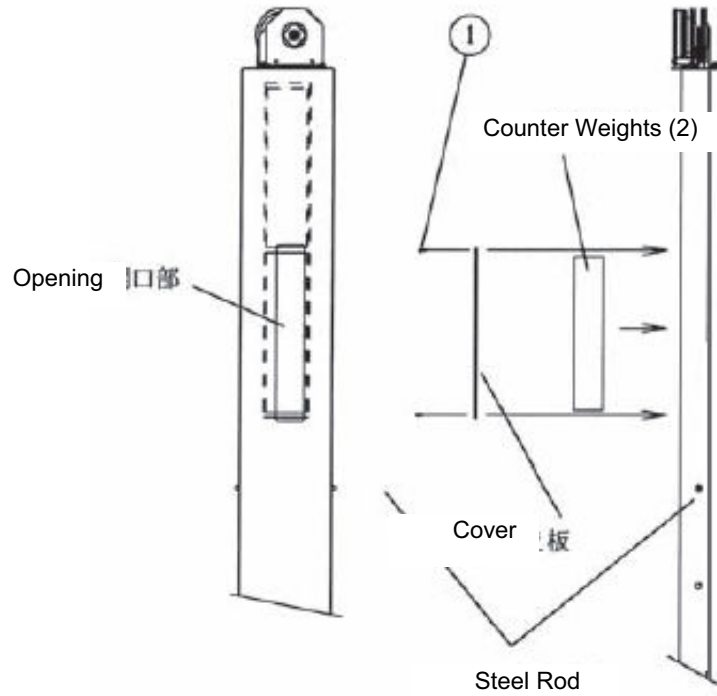

(1): Screw M4 × 10 2 sets

8. Attach pillar cover.

(1): Bind Screw M3 × 6 2 sets

(2): Nylon washer φ3 2 sets

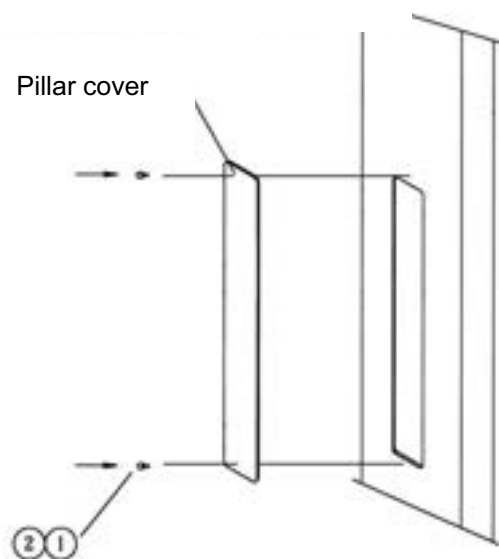

9 Move the equipment to where you place Bel-Cypher N, place two holes of the wall bracket on the screw thread of the concrete strike anchors.

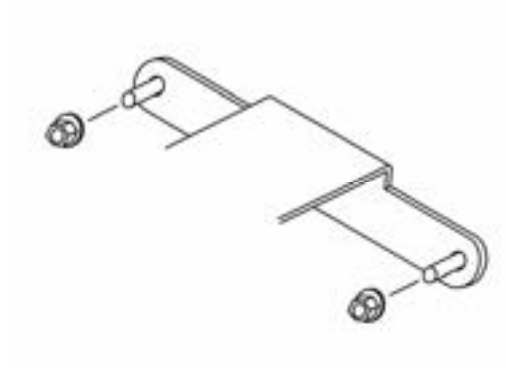

Tighten M8 nuts.

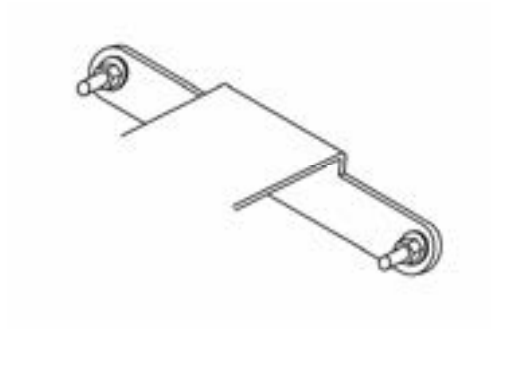

Confirm that the apparatus is securely fixed.

When coach bolts (diameter = 8mm, length = 40mm) are used

- ① Move the apparatus to the place where the Bel-Cypher N is installed.
- ② Tighten coach bolts through holes of the mounting bracket.
If needed, drill holes prior to this step
- ③ Confirm that the apparatus is securely fixed.

10 Method of installing the earth wire

Run the supplied earth wire from the hole located at the bottom of the column to the grounding terminal in the X-Ray room. Connect Earth Wire to facility Earth Ground in accordance with National Electric Code and local codes.

Secure the conductor with a screw and a spring washer. Refer to the figure below.

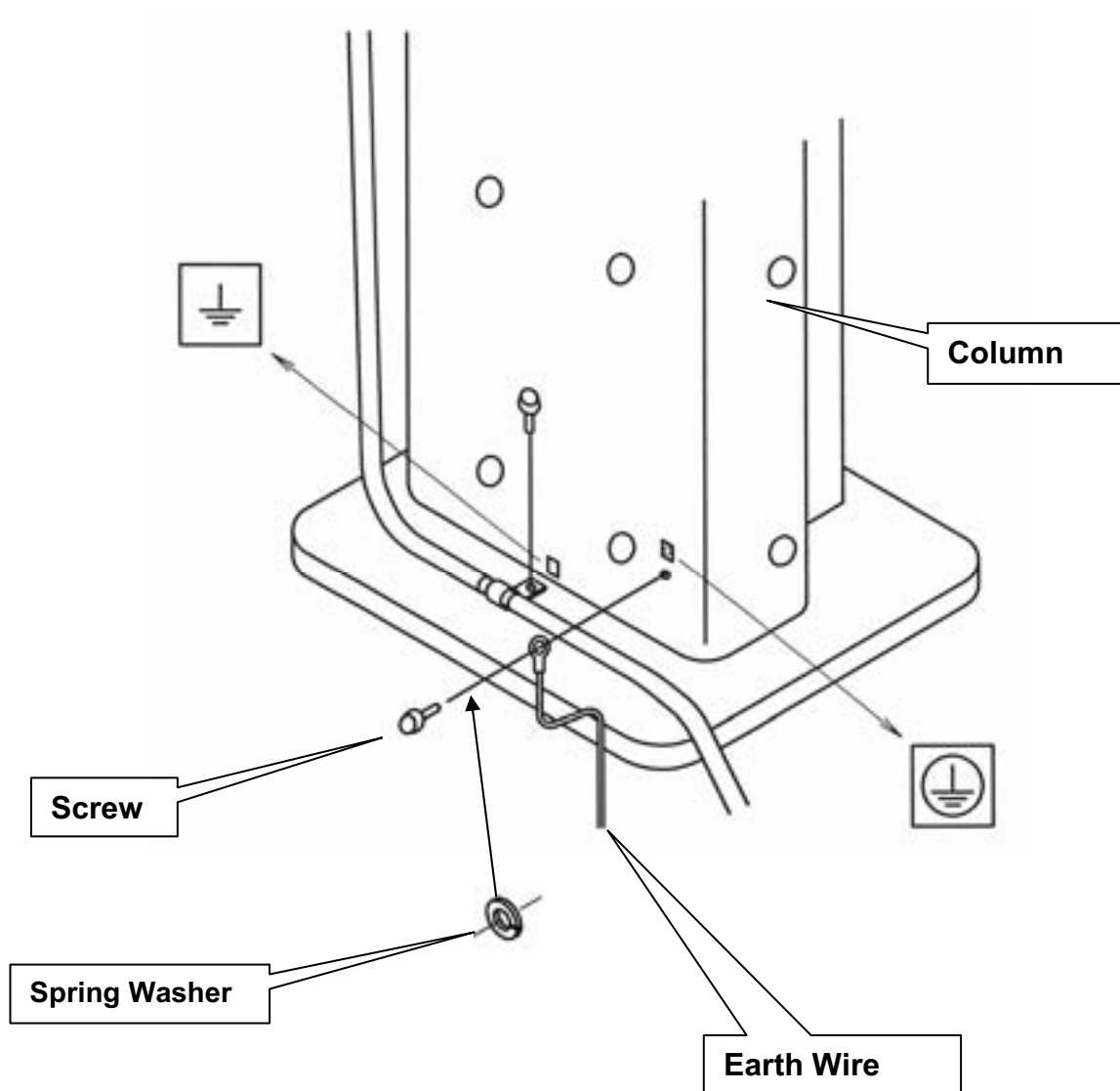

11 Mounting Rotation Unit ASSY on Sliding Unit ASSY

11. 1. By holding carriage holder, with two men, hook the Rotation Unit ASSY onto Sliding Unit.
Align rotation unit by using taper pins.
11. 2. Insert taper pins with a hammer.
11. 3. Tighten and Fix hexagon bolts.

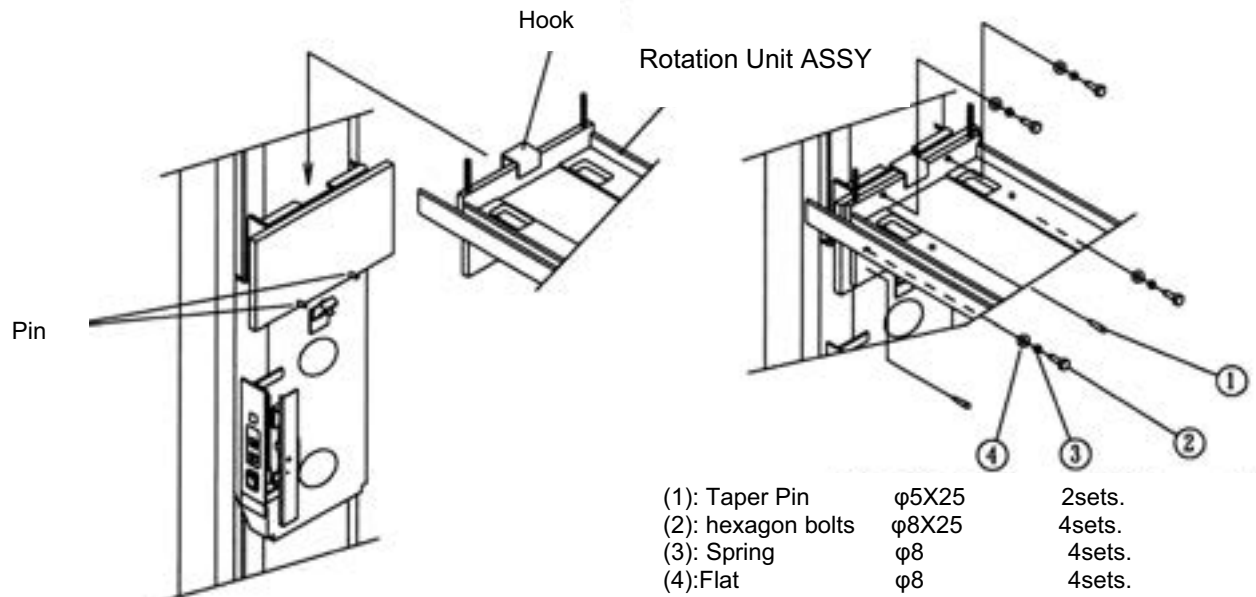

12. Remove Carriage Holder from Rotation unit Assy

Take the carriage holder off the rotation unit assembly.

- (1): Nut ϕ 8 4sets.
- (2): Spring Washer ϕ 8 4sets.

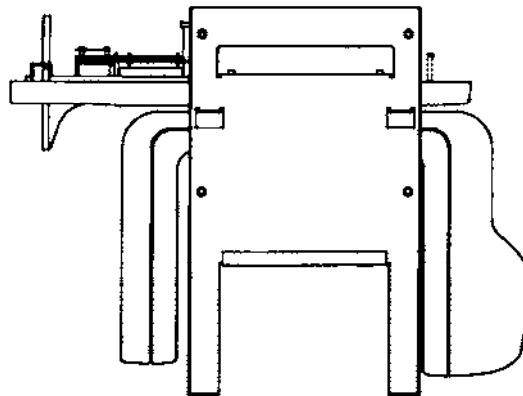
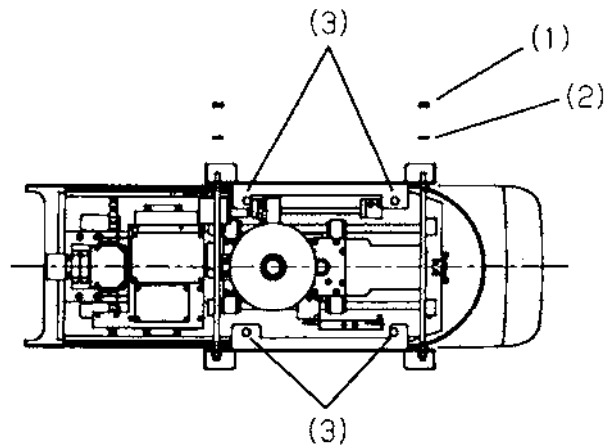

13. Connect the wire harness from Sliding Unit to the PC board of Rotation Unit.

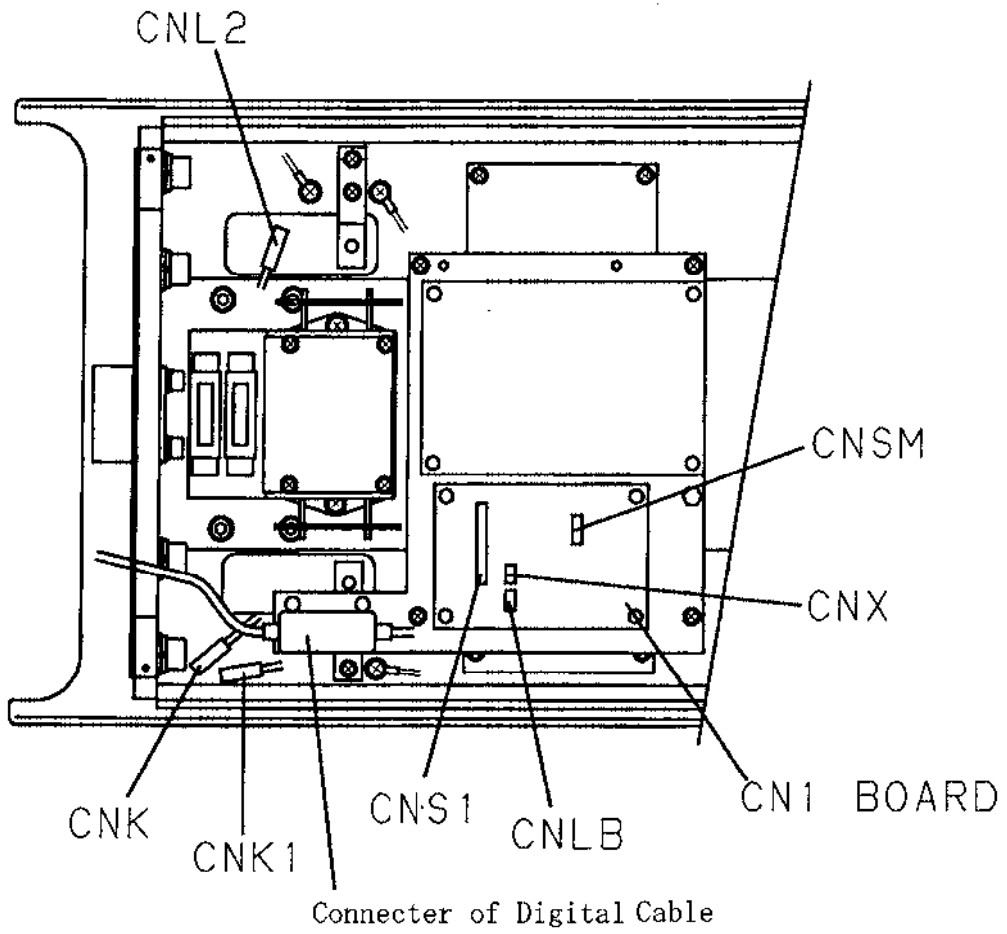

14. Connect the wire harness from Rotation Unit to wire harness from Sliding Unit.

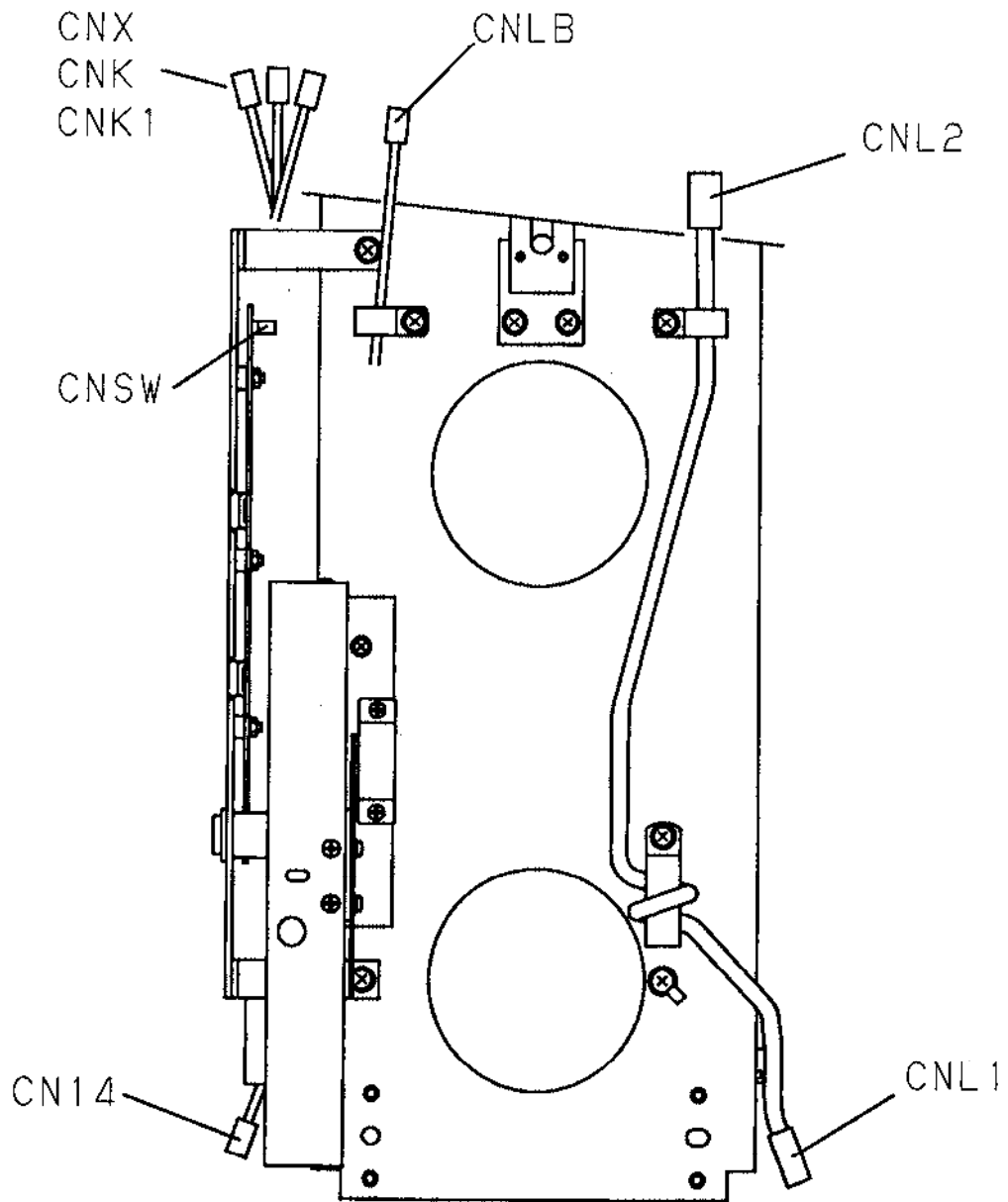

15. Install Chinrest unit to sliding unit.

15. 1. Align positioning pins of Chinrest Unit ASSY to positioning holes of Sliding Unit ASSY.
15. 2. Attach Chinrest Unit by cap screw ①M5×20 (4 sets), Spring washer ②φ 5 (4 sets) & ③Flat washers φ 5 (4 sets).

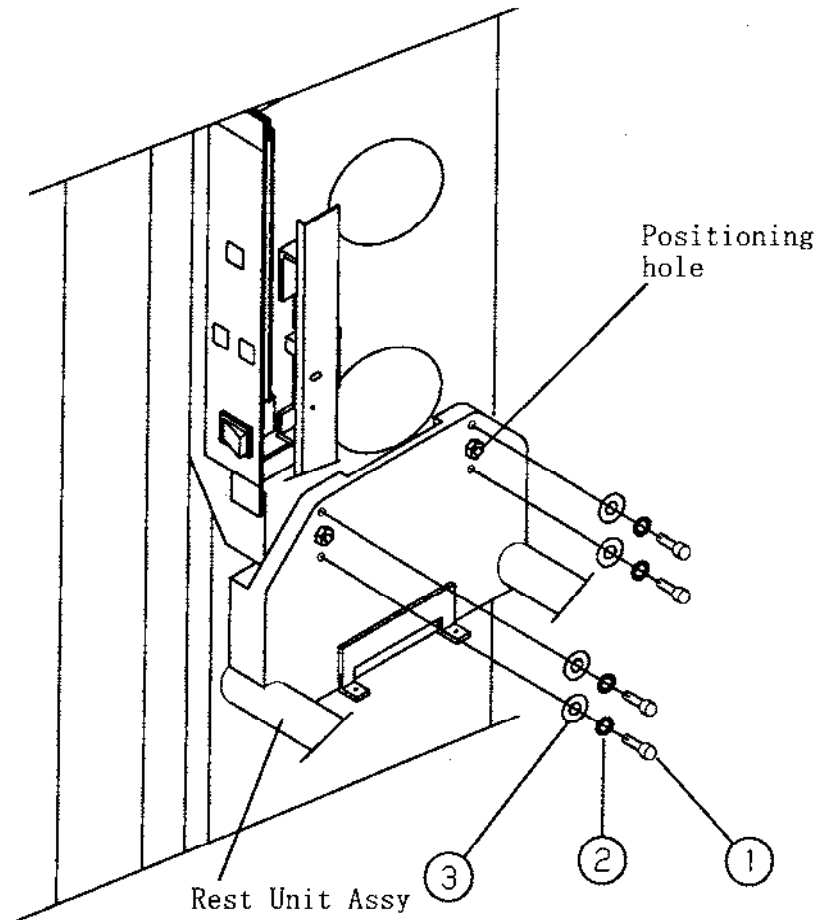

16. Pull out connector(CNSM) through the cut out of the sliding unit cover (Left side)
Put the sliding unit cover from front.



Slowly rotate arm to 90 degrees position.

Turn the ball screw in order to bring rotation unit to forward end.

(1) Bind Screw M3×16 2 sets

(2) Bind Screw M3×8 2 sets

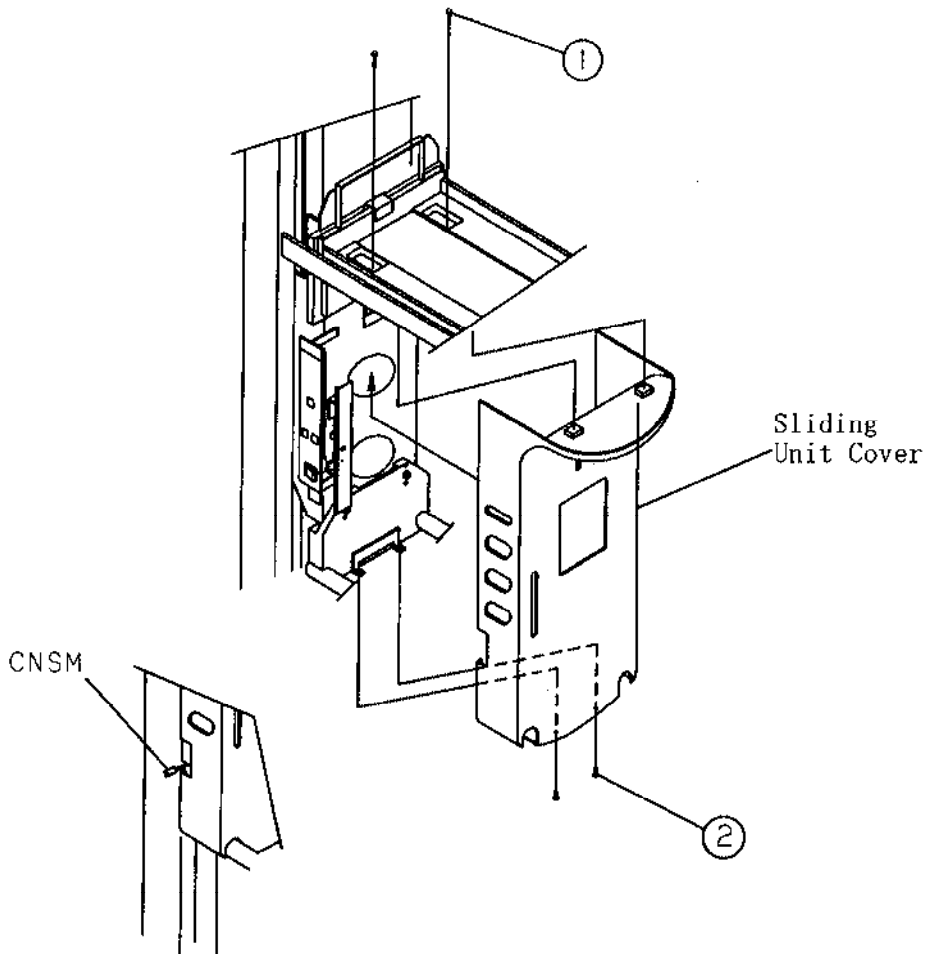

17. Connect the wire harness of handle assy, insert handle to detent pin, fix handle by cap screw.



Connect (CNSM)



Fix by a cap screw M6×40.

18. Put the rotating unit cover on rotating Unit, Put Frankfurt plane knob



Attaches cover.



Fix with two truss screws M3×8.



Frankfurt plane knob

**19 . Remove three hexagon bolts to release brake located at upper part of the Pillar.
These bolts are painted in red. Also Pull out the Steel Rod (refer procedure 4)**

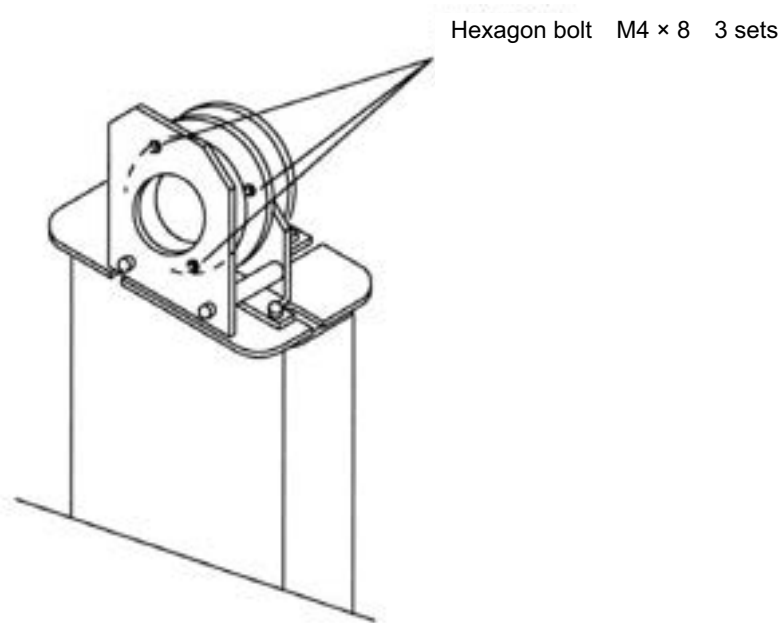

20. Attach the Upper Cover on the Pillar

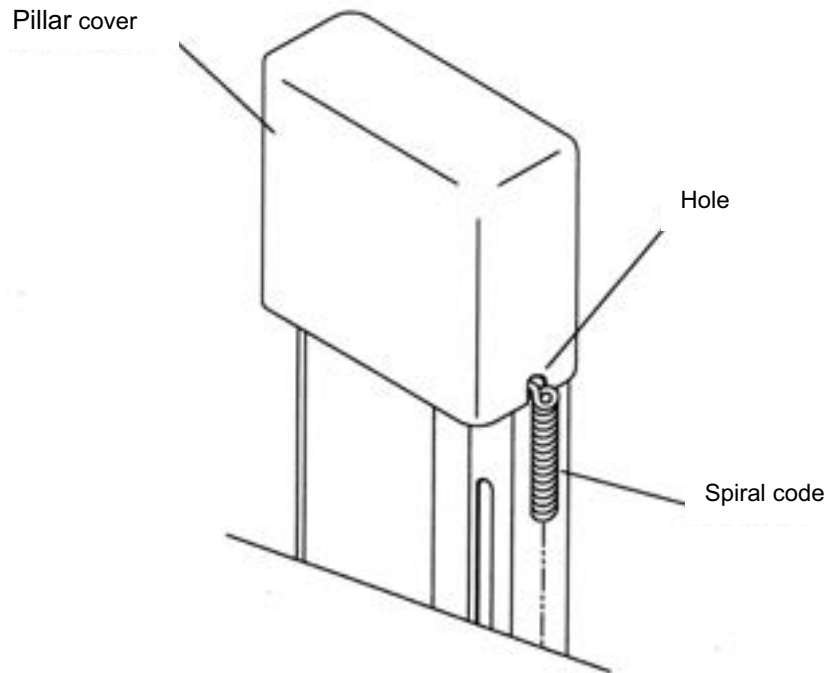

21. Insert Chinrest and Head Holding Rods or Ear Rods to Chinrest ASSY.

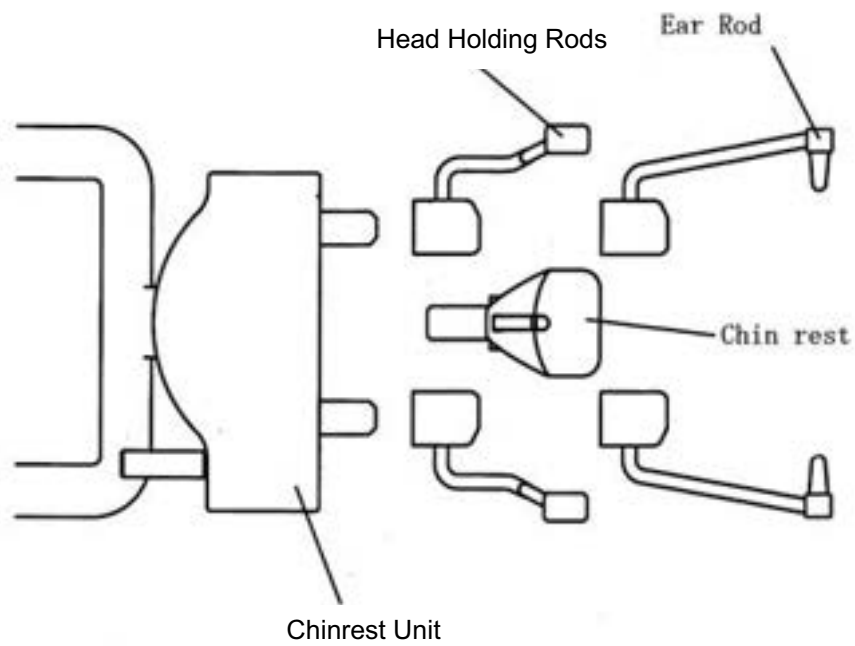

8 . Methods to install a LAN Card for Panoramic radiograph

- 1 . Turn the power of user supplied personal computer off, and unplug the power cable.
- 2 . Open the cover of PC. Insert an expanded LAN Card supplied by user.



- 3 . Start the personal computer, open Start Menu, right click My Network and select “Property”



4. Select “Property” from right clicked menu of Local Area Connection on the added LAN Board.

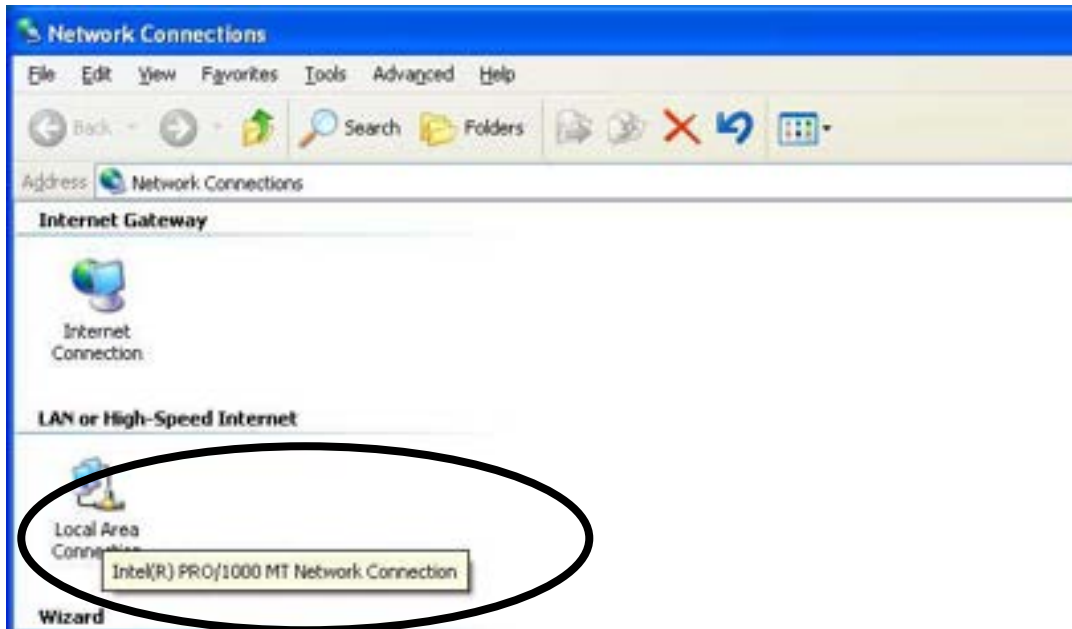

5. Select “Internet Protocol (TCP/IP)” from General Tab, and click “Property” button.

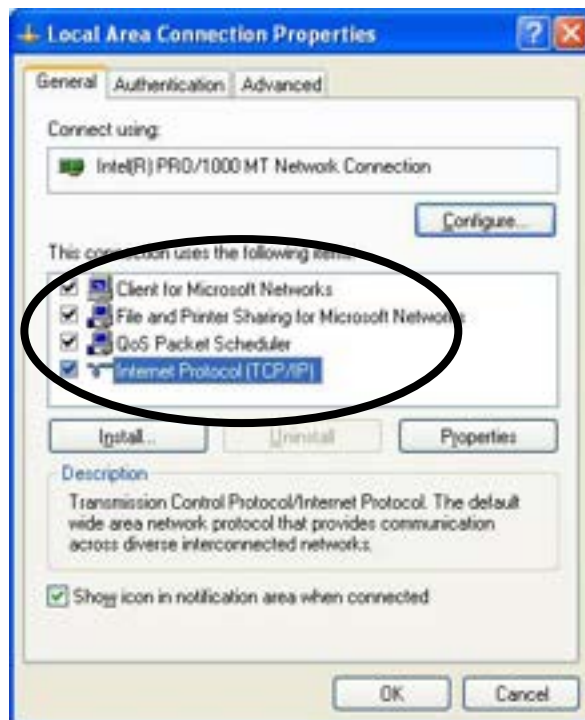

6 . Select “Use following IP Address”, and enter following IP Address and Subnet Mask.

IP Address 「 1 9 2 . 1 6 8 . 0 . 1 0 1 」
Subnet Mask 「 2 5 5 . 2 5 5 . 2 5 5 . 0 」

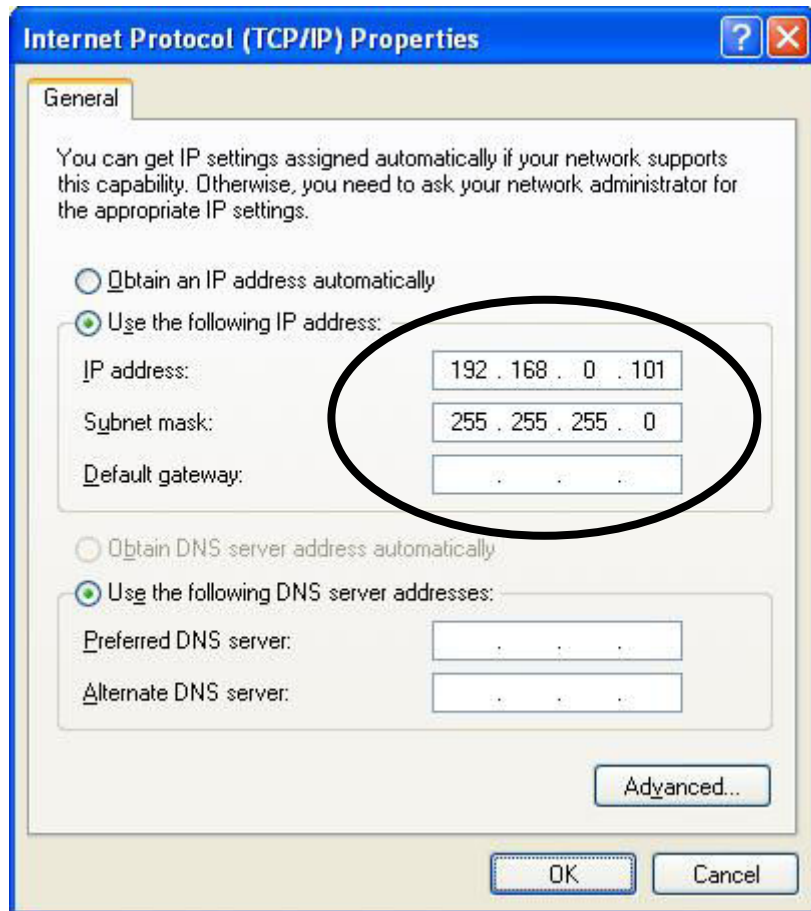

Click “OK”

9 . Methods to install a TWAIN driver in imaging software

1. Insert the CD-Rom supplied with Bel-Cypher N.
2. Run "Setup.exe"
3. TWAIN Drive will be installed automatically.

Recommended specifications of P.C.

O/S:Windows XP Professional SP3 or later 32bit English Version
Windows Vista Business 32bit English Version
Windows 7 Professional 32bit English Version

CPU:Core 2 Duo 2.3GHz~
Main Memory:4GB
Free Space on Hard Disk : 40GB
Port:RS232C port × 1
PCI Slot:Full Size PCI Slot×1

Computer and monitor shall comply with IEC60950-1 or IEC60601-1

Recommended location of P.C.

Place P.C. at least 7 feet away from Bel-Cypher N.

10. Post-Installation Instructions

1. Check listed items by referring to the Operation Manual.

1) Measurement of Feedback voltage and tube current

① Make sure the main power is off. Remove covers from Rotation Unit. (Figure 1)

② Cover radiation aperture with lead

③ Turn on the power of PC that is connected to Bel-Cypher N. Hit Ctrl + Alt + T simultaneously to get into Test mode.

④ Set exposure condition by referring the Operation Manual.

1) Exposure Orbit → Panorama

2) Manual Exposure

3) Tube Voltage: 70kV

4) Tube Current: 8mA

⑤ Irradiate X-ray, then measure the feedback voltage between CP11 & CPCG (Tube voltage), and between CP12 & CPCG (Tube current). (Figure 2)

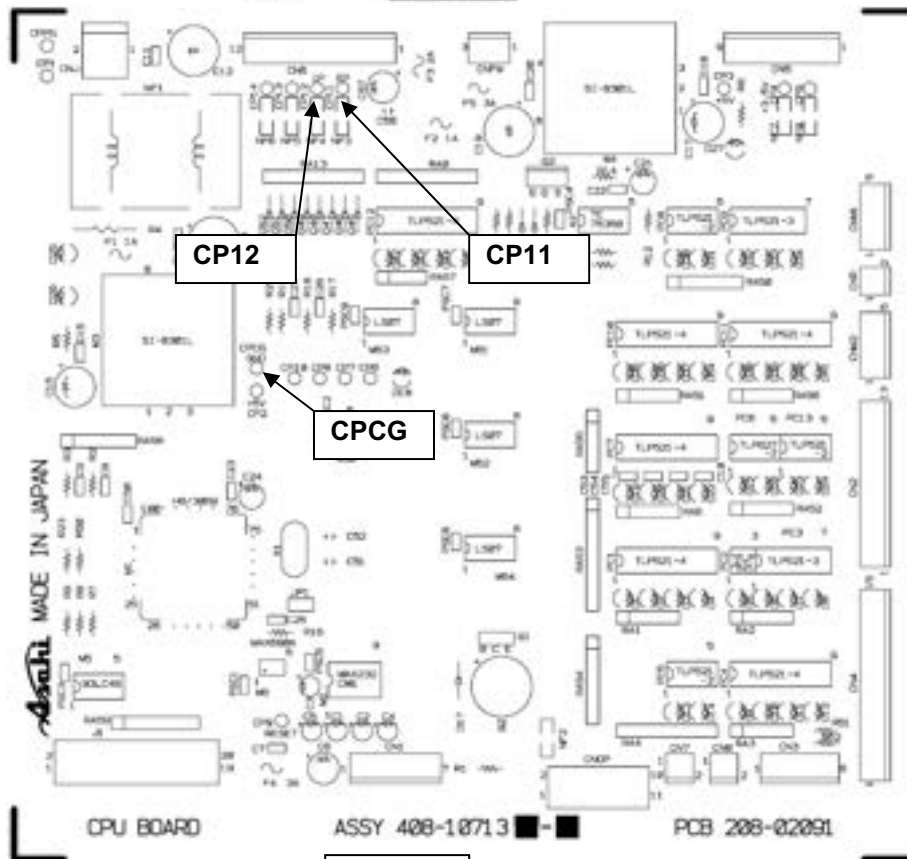
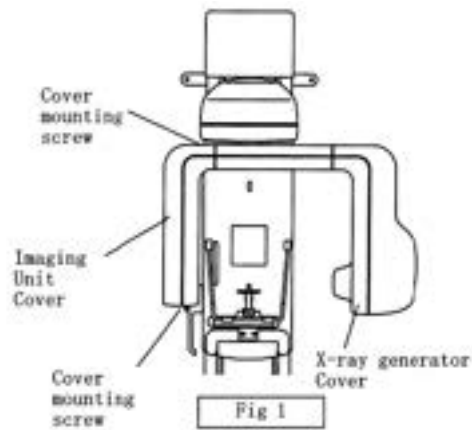

Figure 2

2. Confirmation of movement with X-ray irradiation.

2.1. Check listed items by referring to the Operation Manual.

2.2. Confirm the operation with X-ray

2.2. 1. Cover radiation aperture with lead.

2.2. 2. Set exposure condition by referring the Operation Manual.

- 1) Exposure Orbit → Panorama
- 5) Manual Exposure
- 6) Tube Voltage: 60kV
- 7) Tube Current: 2mA

2.2.3. Irradiate X-Ray and confirm the operation.

3. Check listed items by referring to the Operation Manual

1. Power

- | | | | | |
|----|--|--------------------------|-----------------------------|-----------------------------|
| 1) | Measurement of Input Power | Voltage | | Vac |
| 2) | Does 1) meet the rating description on the Controller plate? | <input type="checkbox"/> | OK | <input type="checkbox"/> NG |
| 3) | Rating Values of the Circuit Protector on the Rotation Unit | Voltage | | V |
| | | Current | | A |
| 4) | Are there any problems when the power plug is inserted? | Heat | <input type="checkbox"/> OK | <input type="checkbox"/> NG |
| | | Allophone | <input type="checkbox"/> OK | <input type="checkbox"/> NG |
| | | Off-flavor | <input type="checkbox"/> OK | <input type="checkbox"/> NG |
| 5) | Does the Power Code have a scratch or a crack? | <input type="checkbox"/> | OK | <input type="checkbox"/> NG |

4. Operation

- | | | | | | | |
|----|---|------------|--------------------------|----|--------------------------|----|
| 1) | After Power On, does the main body have a problem? | Heat | <input type="checkbox"/> | OK | <input type="checkbox"/> | NG |
| | | Allophone | <input type="checkbox"/> | OK | <input type="checkbox"/> | NG |
| | | Off-flavor | <input type="checkbox"/> | OK | <input type="checkbox"/> | NG |
| 2) | After depressing the "RESET" key, is "READY" displayed? | | <input type="checkbox"/> | OK | <input type="checkbox"/> | NG |
| 3) | Does the main body move with up / down switch? | | <input type="checkbox"/> | OK | <input type="checkbox"/> | NG |
| 4) | Does up / down operation of main body have a problem? | Allophone | <input type="checkbox"/> | OK | <input type="checkbox"/> | NG |
| 5) | Does Sliding Unit stop at the highest and the lowest position? | | <input type="checkbox"/> | OK | <input type="checkbox"/> | NG |
| 6) | Positioning Beams in Panorama | | | | | |
| | 6-1) Are all positioning beams turned on by depressing forward / backward switch of Focus Beam? | | <input type="checkbox"/> | OK | <input type="checkbox"/> | NG |
| | 6-2) Dose Forward / backward operation of Focus Beam on ARM work by depressing forward / backward switch? | | <input type="checkbox"/> | OK | <input type="checkbox"/> | NG |

- Beams in T.M.J.
- 7) 7-1) Are all positioning beams turned on by depressing forward / backward switch of Focus Beam? OK NG
- 7-2) Dose Forward / backward operation of Focus Beam on ARM work by depressing forward / backward switch? OK NG
- 8) Are all positioning beams turned off automatically when forward / backward switch of Focus Beam are not depressed for 1 minute? OK NG
- 9) Check in Panorama mode
- | | | | | | |
|---|-----------|--------------------------|----|--------------------------|----|
| 9-1) Does equipment work normally with exposure operation at 0kV, 0mA, at Panoramic mode? | Allophone | <input type="checkbox"/> | OK | <input type="checkbox"/> | NG |
| | Vibration | <input type="checkbox"/> | OK | <input type="checkbox"/> | NG |
-
- 10) Check in T.M.J.
- | | | | | | |
|--|-----------|--------------------------|----|--------------------------|----|
| 10-1) Does equipment work normally with exposure operation at 0kV, 0mA, at TMJ mode? | Allophone | <input type="checkbox"/> | OK | <input type="checkbox"/> | NG |
| | Vibration | <input type="checkbox"/> | OK | <input type="checkbox"/> | NG |
-
- 10-2) After the first exposure, Does Rotation Arm Unit return to start position automatically. OK NG
- 10-3) After the second exposure, Does Rotation Arm Unit stop at the end position. OK NG
- 11) Does the buzzer sound to facilitate "Turning the Power Switch OFF" in 5 minutes later after the last operation? OK NG
- 12) After power is turned off automatically, Will power turn on again normally? OK NG
5. Externals
- 1) Are there scratches or cracks? OK NG
- 2) Are all covers secured with screws? OK NG

11. Contacting information

Belmont Equipment

A Division of TAKARA BELMONT USA, Inc.

101 Belmont Drive

Somerset, NJ 08873

Toll Free (800) 223-1192

Toll Free Fax (800) 280-7504

www.belmontequip.com

TAKARA COMPANY, CANADA, LTD.

2706 South Sheridan Way

Mississauga, Ontario, Canada L5J 2M4

Toll Free (800) 268-5351

Fax (905) 822-6203

www.takarabelmont.ca

12. Revision data of this manual

This manual was created on Oct 2008.
Revised March 2011

Document number : B02-T170