

Bel-Halo

LED DENTAL LIGHT

Model AL-920X

BDS-2536

Including
Light of BDS-2572
Top of BDS-2532

INSTALLATION INSTRUCTIONS

Ver. 1-01

 **IMPORTANT**

After installation is completed, check all the bolts, screws and fasteners to confirm that they are securely fastened.

 **Belmont**

TABLE OF CONTENTS

[1] Major parts identification	-----	5
[2] Specifications	-----	5
[3] Classification	-----	5
[4] Electric and flow diagram	-----	6
[5] Dimensions	-----	8
[6] Installation	-----	8

Intended Use of the Product

This product is intended for the exclusive use for diagnoses, treatments and relative procedures of dentistry, and must be operated or handled by the qualified dentists or by dental staffs under the supervision of the dentist. Such dentists or dental staffs should instruct and/or assist the patients to approach to and leave from the product. Patients should not be allowed to operate or handle the product unless he/she is so instructed.



WARNING

Operation of a dental light under Electro Magnetic Interferences.
This equipment may malfunction by electromagnetic interferences.
Do not install dental light close to the equipment that generates electromagnetic interference (i.e. communication equipment, elevator)
Do not use the device that creates interference (i.e. cellular phone) near this equipment.
Do not use electric surgical knife or laser knife with dental light.
Light may turns on/off by itself due to malfunction of a sensor caused by electromagnetic interferences.

Symbols



Caution, Warning or possibility of danger



Manufacturer

Environmental condition for Operation

Temperature : 41~104F (5 ~ 40 C)

Humidity : 10 ~ 80%

Pressure : 8.7~15.4 psi (600 ~ 1060 hpa)

Environmental condition for Storage

Temperature : -4~158F (-20 ~ 70 C)

Humidity : 10 ~ 80%

Pressure : 8.7~15.4 psi (600 ~ 1060 hpa)

Environmental condition for Transportation

Temperature : -4~158F (-20 ~ 70 C)

Humidity : 10 ~ 80%

Pressure : 8.7~15.4 psi (600 ~ 1060 hpa)



WARNING

- To avoid the risk of electric shock, this equipment must only be connected to supply mains with protective earth.
- Position a light head by holding light handle(s).
- Installation and service work should be conducted by an authorized installation/service personnel only.



WARNING The followings are prohibited

- To modify this equipment.
- To use the equipment under any failure condition.
- To use the equipment without doing the daily and periodical check-up.
- To wipe the plastic covers with any disinfectant or detergent that contains organic solvent.

Precautions for installation

- Keep the equipment away from water.
- Keep in circumstances safe from influence by temperature, humidity, wind, sun light, air containing salts and minerals.
- Care about stability such as inclination, vibration and impact, including handling and transportation.
- Do not keep the equipment in a place where chemicals are or where gas is emitted.
- During lifting and unpacking of the light, make sure to hold only the designated parts.
- Do not drop or hit the light.
- Do not connect to power supply other than AC120V 60HZ.
- Ground light properly prior to turning power on.
- When the installation process has been completed, verify that all the mechanical and electrical functions are working properly.
- Thick gloves are highly recommended at unpacking.
- Do not modify this equipment.



CAUTION

Before use

- Check connection of switches and make sure that the device functions properly.
- Make sure that grounding wire is connected.
- Make sure that cables are properly and perfectly connected.

During use

- Do not use the light longer than required for examination or treatment.
- Always watch the patient and the equipment to make sure nothing is wrong.
- If anything wrong is observed with the equipment or the patient, take a proper action, such as stopping the use of equipment as well as keeping the patient in safe.
- Keep an eye on the patient not to touch the equipment.

After use

- Turn off the light.
- Clean the equipment and get it ready for use.



CAUTION

Do not spray liquids directly onto light surfaces. In order to prevent damage to electrical components and systems, do not apply excess cleaning solution onto light surfaces.

Note

Warranty does not cover damage to equipment caused by disinfectant solutions

[1] MAJOR PARTS IDENTIFICATION

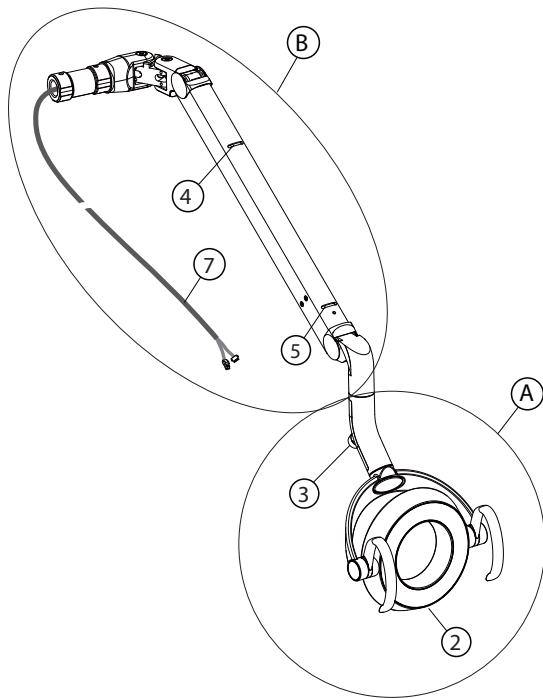

- (A) LED light head assembly
- (B) Balance arm assembly
- 1. Mode selection switch
- 2. Touchless sensor switch
- 3. Intensity control volume
- 4. Slot A for Adjusting Tension of Balance Arm
- 5. Slot B for Adjusting Angle of Head
- 6. Power supply box assembly
- 7. Light assembly wire harness
- 8. Power supply box wire harness

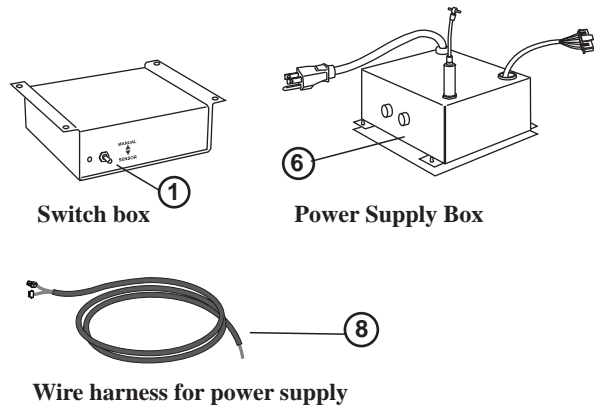

[2] SPECIFICATIONS

- 1. Focal Distance..... 25.6" (650 mm)
- 2. Color Temperature..... 5000° Kelvin
- 3. Light Intensity
 - Regular Operation Mode 4000 Lux / 370 FTC ~ 32000 Lux / 2970 FTC
 - Composite Mode 5500 Lux / 510FTC
- 4. Light Pattern..... 3.2" x 5.5" at 25.6"
- 5. Power Requirement..... AC. 120V / 60 Hz / 0.43A

[3] CLASSIFICATION

- a. Protection against electric shock : Class I Equipment.
- b. Equipment not suitable for use in the presence of a flammable anesthetic mixture with air or with oxygen or nitrous oxide.

[4] ELECTRIC AND FLOW DIAGRAM

4-1 ELECTRIC DIAGRAM

Settings of PCB dip switches (SW3,4) and jumper pin (JP3).

Setting	Setting condition	Default setting
1	Test mode (Always OFF) Off: Normal operation, On: Test operation	OFF
2	Transition time to Composite mode (by a sensor) Off: 1 second, On: 2 seconds	ON
3	Wake-up brightness setting from light off condition. Off: 1. Composite Mode when a light is turned on by using a sensor. : 2. Keeps on getting on/off signal from dr table, light stays in composite mode. On: 1. Regular Mode when a light is turned on by using a sensor. : 2. Keeps on getting on/off signal from dr table, light goes into regular mode.	ON
4	Combining dental unit Off: Clair unit, On: CP-One plus	OFF

Setting	Setting condition	Default setting
5	Sensor activation setting Off: Activate when a hand goes away, On: Activate when a hand comes in.	OFF
6	Includes Composite Mode Off: Yes, On: No	OFF
7	Speed setting of communication line Off: 4800bps, On: 2400bps	OFF
8	LED blink setting of Composite Mode Off: Slow blinking, On: Rapid blinking	OFF
SW4	PC side: Clair Unit, 232 side: CP-One plus	PC
JP3	PC side: Clair Unit, 232 side: CP-One plus	PC

Remarks
Connector Symbol
SM...SM Connector
XA...XA Connector
XM...XM Connector
Black dot
The side with black dot has male pins
Receptacle
Plug

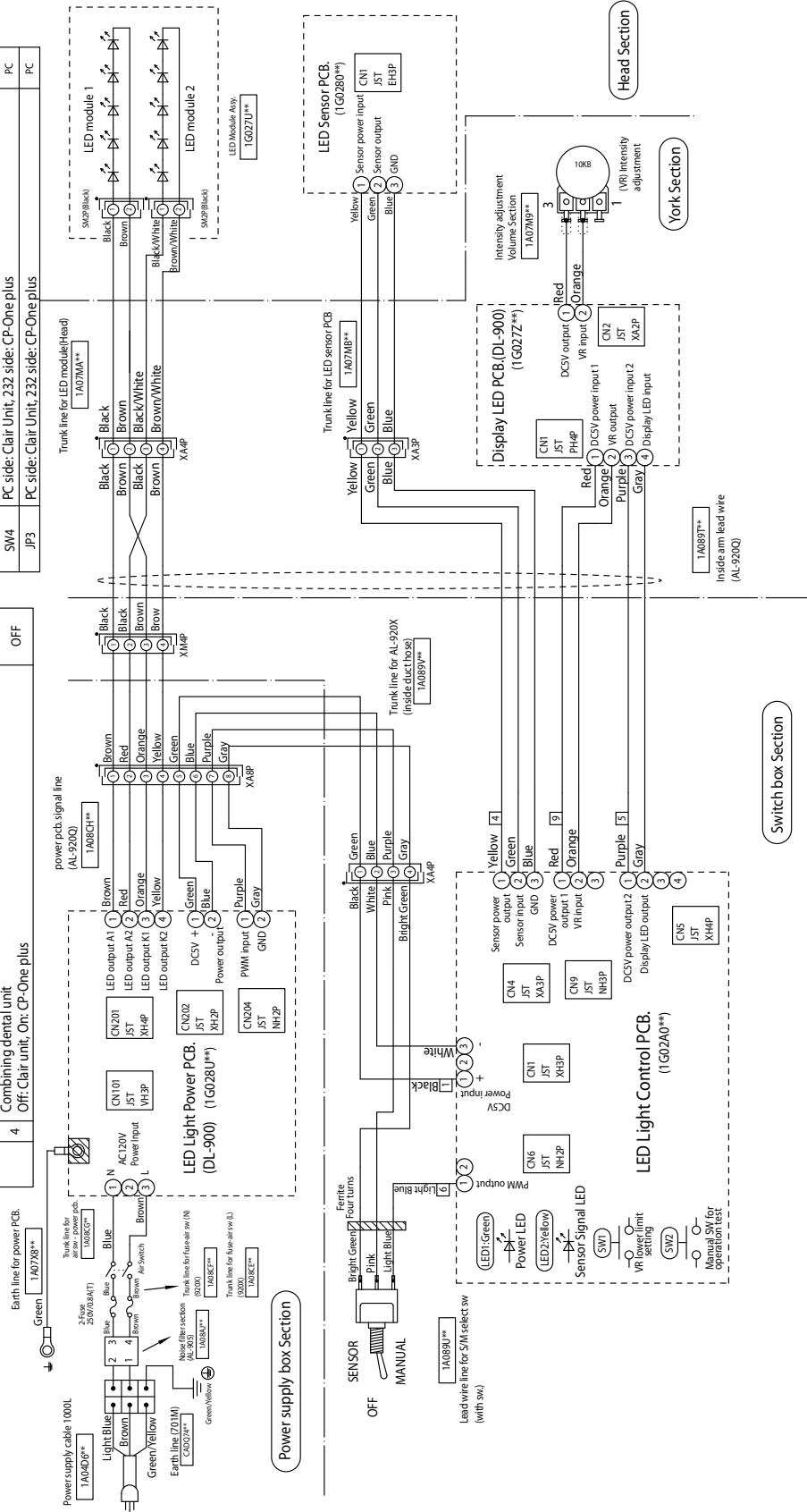

4-2 FLOW DIAGRAM

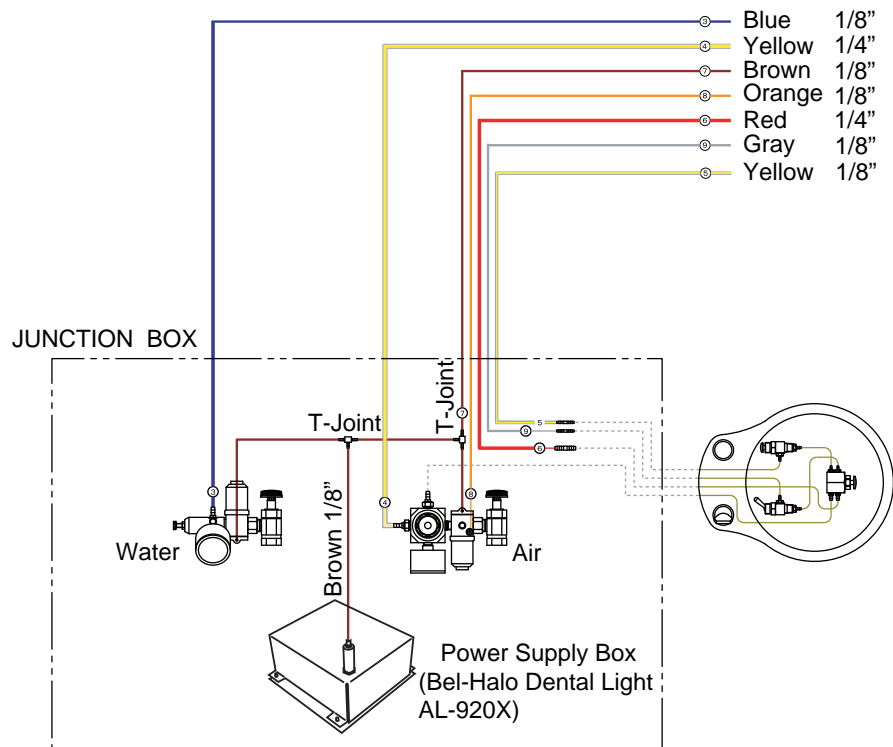

[5] DIMENSIONS

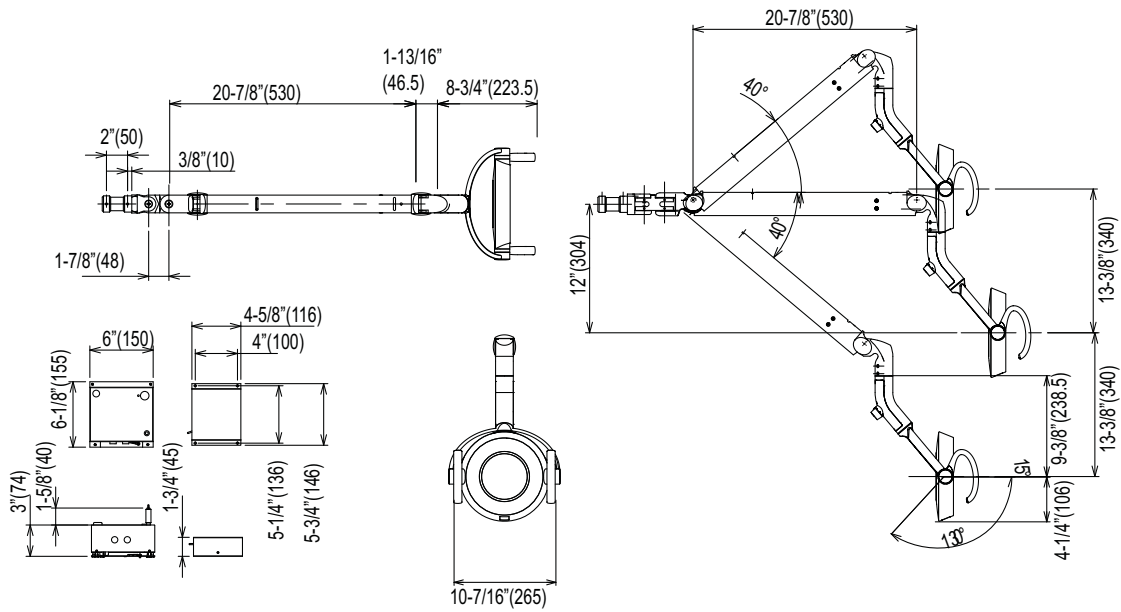

[6] INSTALLATION

6-1. Attach the light assembly to the light pole

Feed the wire harness coming from the balance arm joint through the light pole. Insert the balance arm joint of the light into the light pole. Fasten with two M6 x 12mm screws.

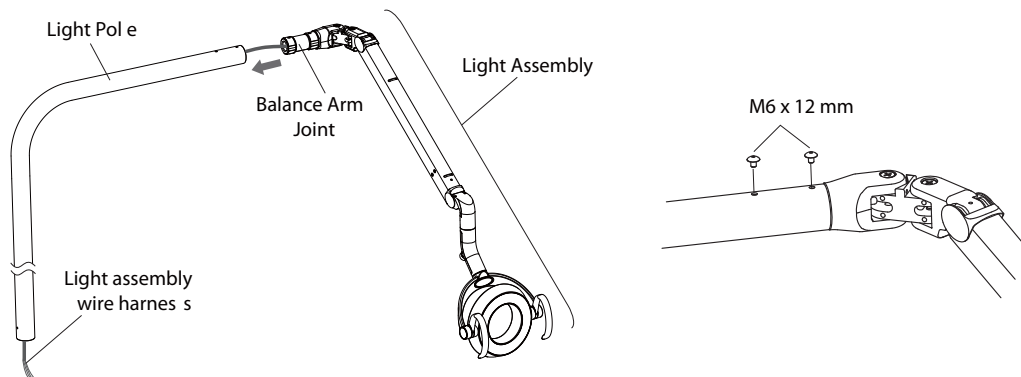

6-2-1 Feed the light assembly wire harness through the swing arm (BDS-2572 / BDS-2531)

Feed the light assembly wire harness through the swing arm and pull the end of the harness from the lower end of the swing arm. Mount the light assembly onto swing arm.

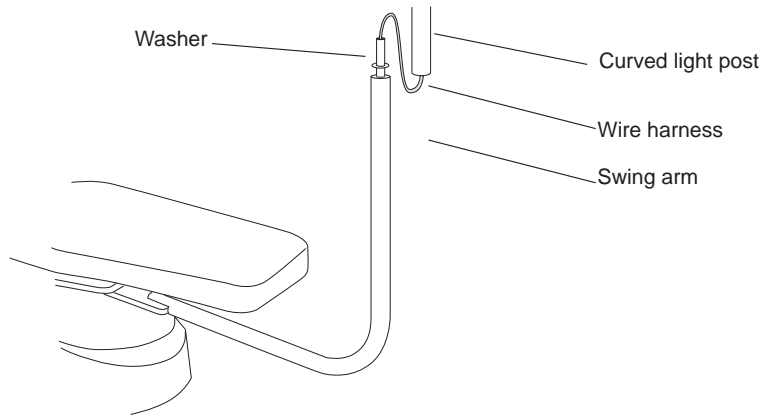

6-2-2 Feed the light assembly wire harness through the light support rod (BDS-2536 on BDS-2500/2510/2505/2515/2520)

Feed the light assembly wire harness through the light support rod and pull the end of the harness from side of the PMU post as below.

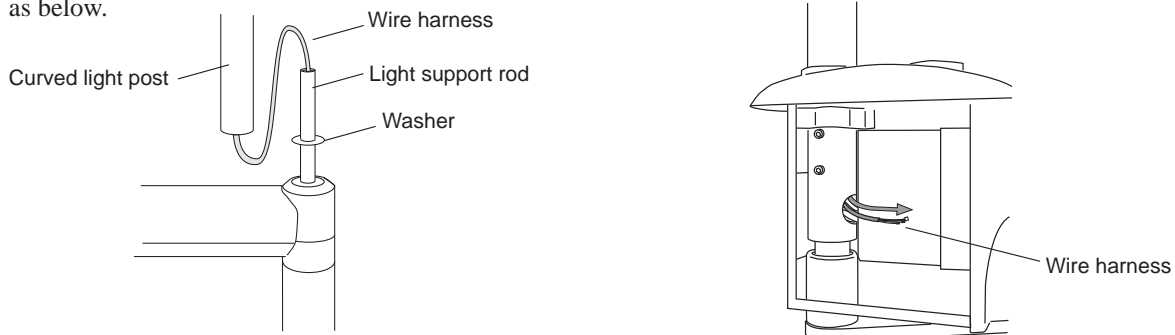

6-2-3 Insert the brake disks and set screws into the curved light post

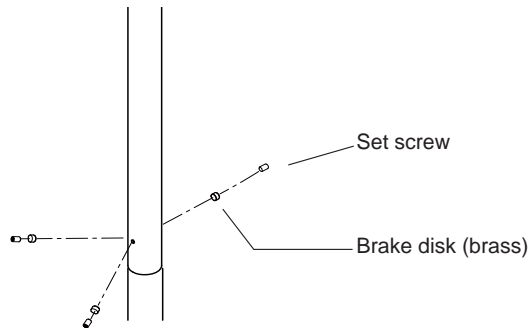

6-3 Place the power supply box inside J.box, then feed the wire harness through the umbilical. The end with flat 8 P connector should be on J.box end.

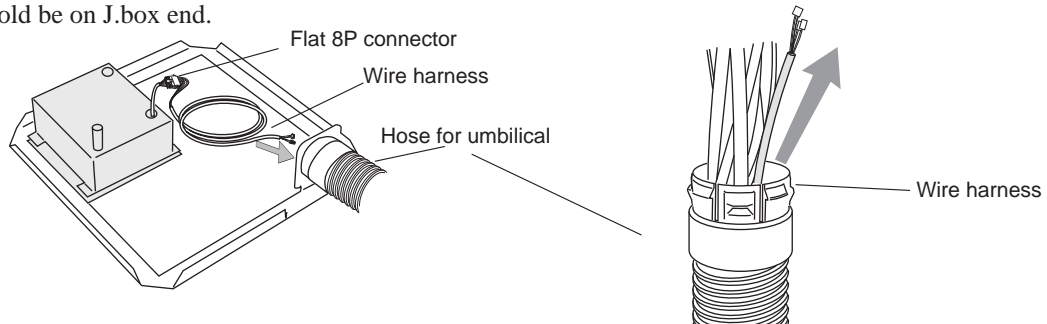

6-4 Open the control box and connect the connectors with the wire harness from the light head and the other wire harness from the power supply box. Follow the drawing below.

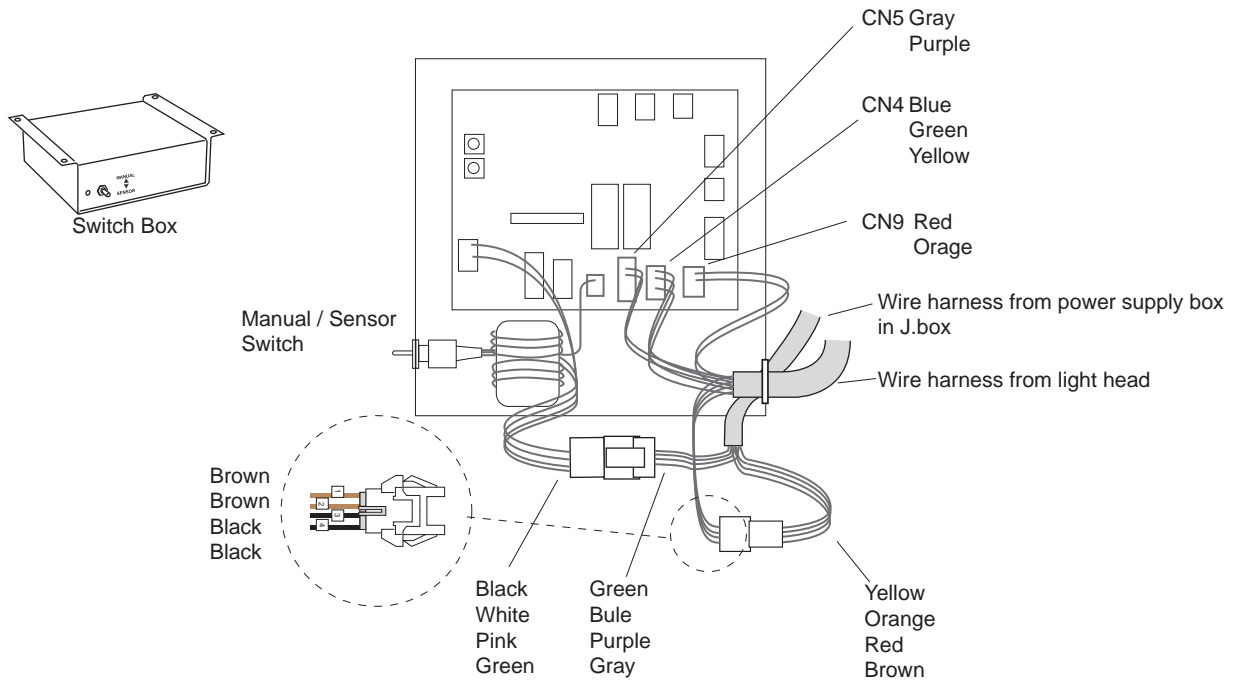

6-5-1 Attach the control box onto the bottom of mounting bracket (BDS-2572 / BDS-2531)

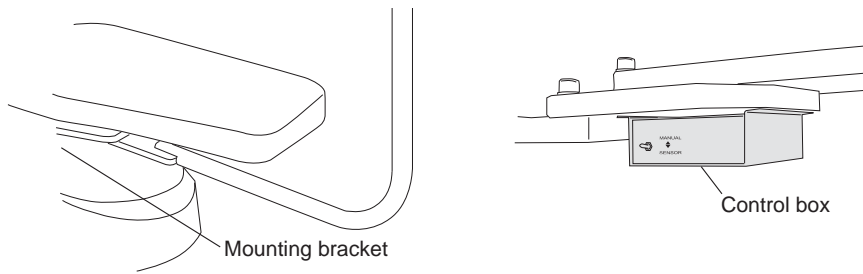

6-5-2 Attach the control box onto the metallic plate inside PMU (BDS-2536 on BDS-2500/2510/2505/2515/2520)

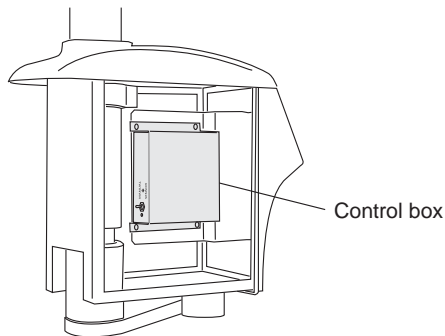

6-6 Connection of power supply box

Connect the wire harness, brown tubing as per the following diagram.

After all the connection is completed, connect the power plug to AC120V.

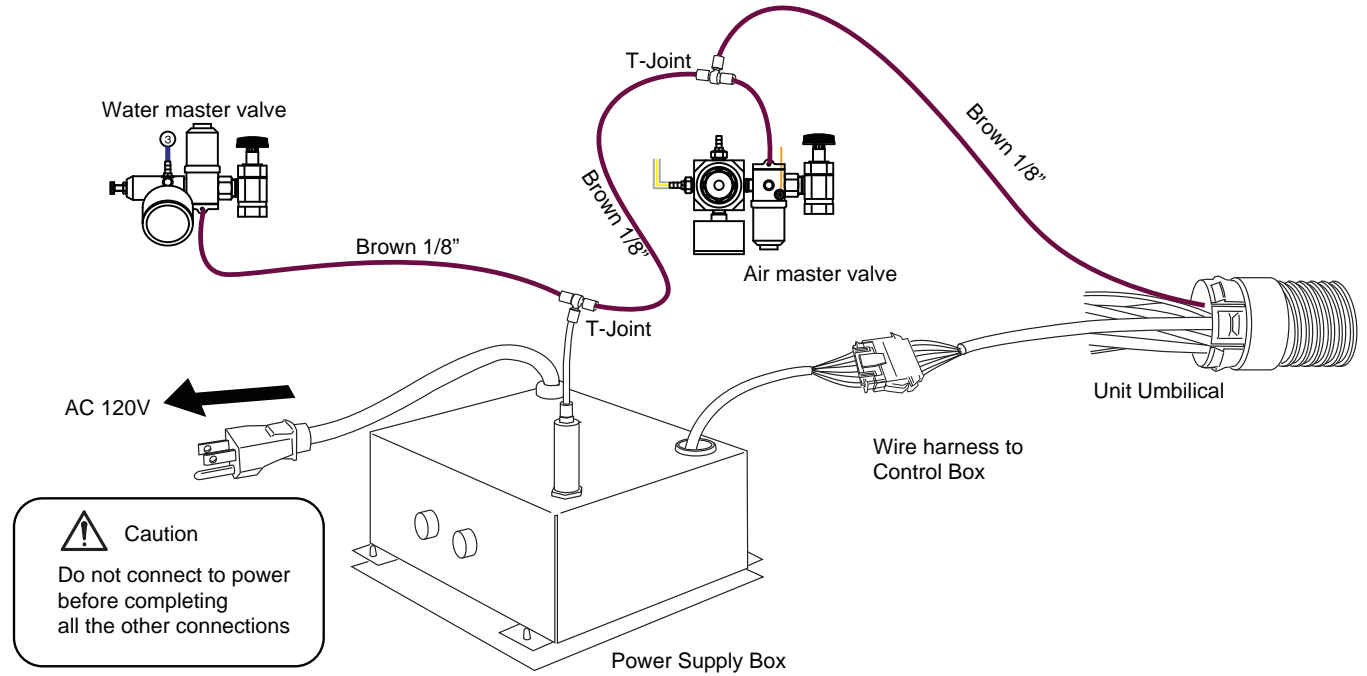

NOTE



BELMONT EQUIPMENT, Division of Takara Belmont USA, Inc.

101 Belmont Drive Somerset, New Jersey 08873 U.S.A. TEL.:(732) 469-5000 / (800) 223-1192 Fax.:(732)356-1035

TAKARA CO, CANADA LTD.

2076 S. Sheridan Way, Mississauga, Ont., L5J2M4, Can. TEL.:(905) 822-2755 Fax.:(905)822-6203



TAKARA BELMONT CORPORATION (Manufacturer)

1-1, 2-Chome, Higashi-shinsaibashi, Chuo-ku, Osaka, Japan TEL.: 81-6-6213-5945 FAX.: 81-6-6212-3680