

BELRAY

MODEL 096

DENTAL X-RAY

·Wall Mount TypeWK

·Room Mount TypeRK

**INSTALLATION
INSTRUCTIONS**
(for USA & Canada)

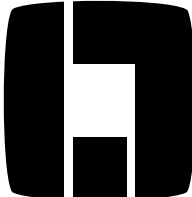
 **Belmont**

INDEX

	PAGE
SECTION ONE : TECHNICAL DATA	
[1] ELECTRICAL AND RADIATION DATA.....	3
[2] PHYSICAL DIMENSIONS	4
[3] TUBE HEAD THERMAL CHARACTERISTICS	5
SECTION TWO : PRE-INSTALLATION INSTRUCTIONS	
[1] SUPPORT REQUIREMENTS	6
[2] ELECTRICAL REQUIREMENTS	6
[3] LOCATION OF COMPONENTS	7
SECTION THREE : INSTALLATION INSTRUCTIONS	
[1] INSTALLATION REQUIREMENTS	8
[2] UNPACKING	8
[3] ARM ASSEMBLY INSTALLATION.....	9
[4] HEAD ASSEMBLY INSTALLATION	12
[5] CONTROL BOX INSTALLATION.....	12
SECTION FOUR : POST INSTALLATION INSPECTION	
[1] ARM ASSEMBLY	14
[2] BALANCE ARM ASSEMBLY	15
[3] HEAD POSITIONING	15
SECTION FIVE : CONTROL IDENTIFICATION AND OPERATION	
[1] CONTROL IDENTIFICATION	16
[2] FUNCTION OF CONTROLS	16
[3] OPERATING PROCEDURES	18
[4] ERROR CODES	19
SECTION SIX : POST INSTALLATION CONFIRMATION	
[1] CONFIRMATION OF POWER SUPPLY VOLTAGE.....	20
[2] CONFIRMATION OF TUBE CURRENT	20
[3] CONFIRMATION OF EXPOSURE WARNING LAMP & BUZZER.....	20
[4] CONFIRMATION OF LINE VOLTAGE REGULATION	20
SECTION SEVEN : INITIAL SETTING	
[1] FILM SPEED.....	21
[2] PRIORITY OF SELECTIONS	23
[3] ELECTRONIC CHIME ON/OFF	23
APPENDIX ONE : CIRCUIT DIAGRAM	23
APPENDIX TWO : PARTS IDENTIFICATION	
[1] ,[2] ARM AND HEAD / CONTROL BOX ASSEMBLY	24
[3] SLIDING SECTION / ARM AND HEAD ASSEMBLY OF RK TYPE.....	26
APPENDIX THREE : CERTIFICATION	28

⚠ CAUTION

This manual provides information and instructions for the installation, assembly calibration and certification procedures for **BELMONT BELRAY MODEL 096** dental x-ray. The instructions contained in this book should be thoroughly read and understood before attempting to install the X-ray unit. After the installation is complete, file this manual and refer back to it when performing periodic maintenance.

SECTION ONE : TECHNICAL DATA

[1] ELECTRICAL AND RADIATION DATA

1. Focal point measurement	0.8 mm x 0.8 mm		
2. Rated peak tube potential.....	70 kVp		
3. Rated tube current.....	10 mA		
4. Maximum rated peak tube potential	70 kVp		
5. Rated line voltage	120 V AC		
6. Line voltage range.....	108 V AC ~ 132 V AC		
7. Range of line voltage regulation	2 ~ 5 %		
8. Rated line current.....	10.8 A at 70 kVp, 10 mA		
9. Maximum line current.....	11.9 A at 70 kVp, 10 mA		
10. Exposure time	0.02 ~ 3 sec. (ON and OFF are zero crossed.)		
11. Timer accuracy	± 1 pulse (1/60 sec.)		
12. Inherent filtration	1.3 mmAl Equivalent		
13. Added filtration	0.8 mmAl		
14. Minimum filtration permanently in useful beam	2.1 mmAl Equivalent at 70 kVp		
15. Nominal roentgen output			
a. Distal end of regular cone	8.2 mGy/sec. + 30 %, - 40 %		
b. Distal end of long cone	3.7 mGy/sec. + 30 %, - 40 %		
	(Data obtained by direct measurement in the useful beam)		
16. Source to skin distance			
a. Regular cone.....	204 mm		
b. Long cone.....	305 mm		
17. Leakage technique factor	70 kVp / 0.16 mA		
	0.16 mA is maximum rated continuous current for 10 mA with a duty cycle 1: 60		
18. Duty cycle	1: 60 (0.5 sec. exposure with 30 sec. interval)		
19. Maximum deviation of tube potential and tube current	Pulse	Tube Potential	Tube Current
	1st,2nd & 3rd	70 ⁺⁸ ₋₁₁ kVp	10 ± 2 mA
	4th & Up	70 ⁺⁷ ₋₁₀ kVp	10 ± 1 mA
20. Measurement base of technique factors			
a. peak tube potential	Peak tube potential of conducting half cycle		
b. tube current	Average of tube current during one cycle of line frequency		
c. exposure time	Impulses of power line frequency		
21. Half value layer.....	1.5 mmAl over		
22. Source to the base of cone distance	81 mm		

[2] PHYSICAL DIMENSIONS

() = mm

096-WK

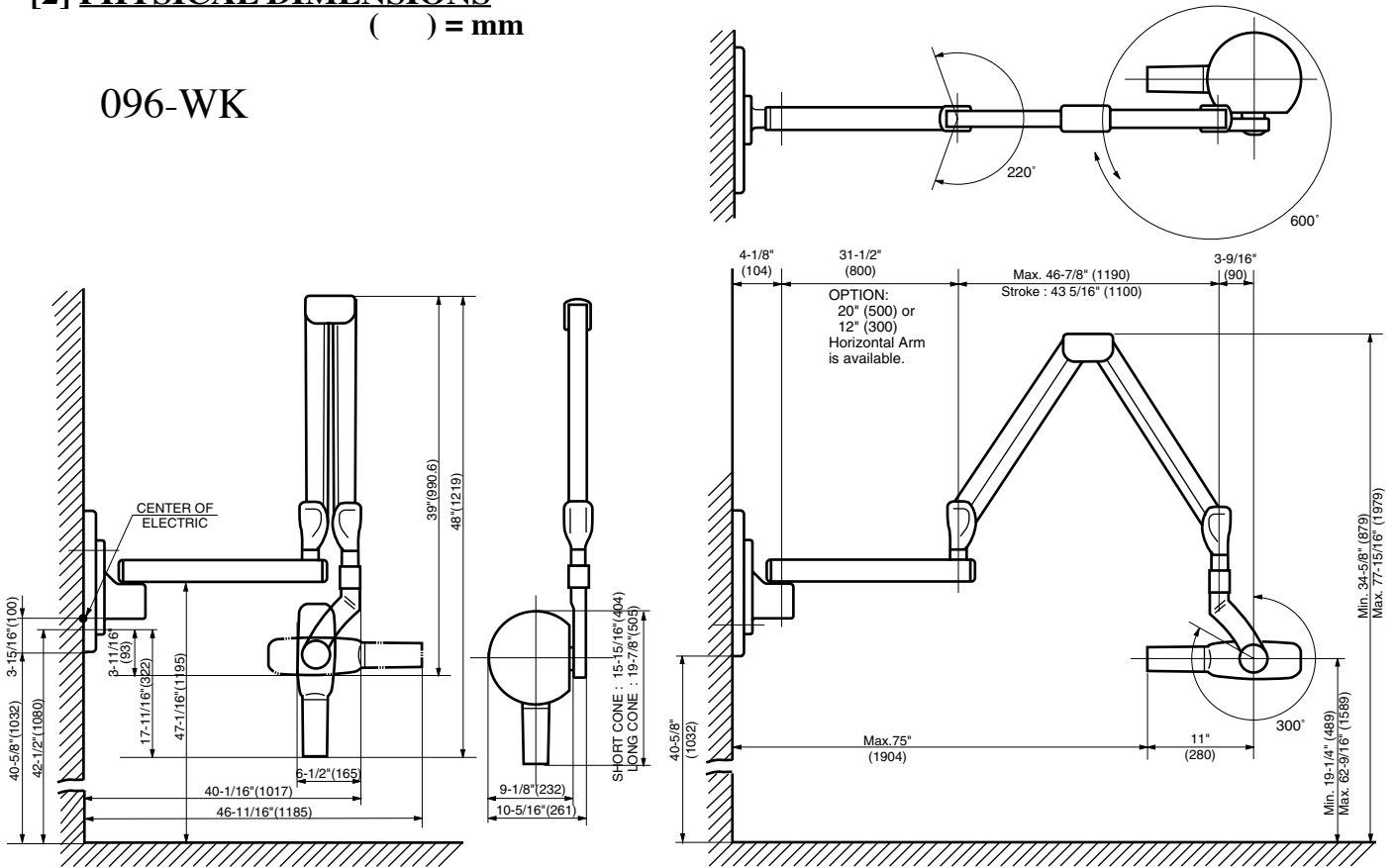

096-RK

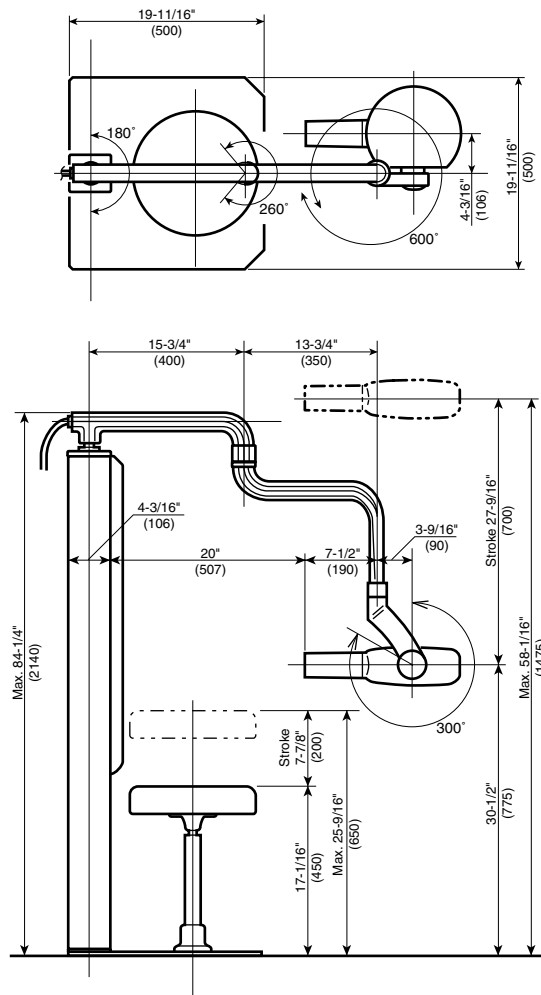

From 2004 July

[3] TUBE HEAD THERMAL CHARACTERISTICS

A. Interval between each exposure

The temperature inside of the tube head rises, when an exposure is made. The value of the heat generated is measured in Heat Unit (HU), which is the product of tube potential, tube current and exposure time. Excessive heat will be accumulated inside of the tube head, if the x-ray is used without a proper cool down interval between each exposure. The excessive heat may damage the x-ray tube, high voltage generator or both.

B. Duty cycle

To avoid the accumulation of excess heat in an effort to prolong the tube head life, a cool down interval of 60 seconds or more must be allowed between each 1 second exposure. or a 30 second cool down must be allowed between each 0.5 second (30 impulses) exposure.

C. Tube head cooling curve

1. Tube Housing cooling curve

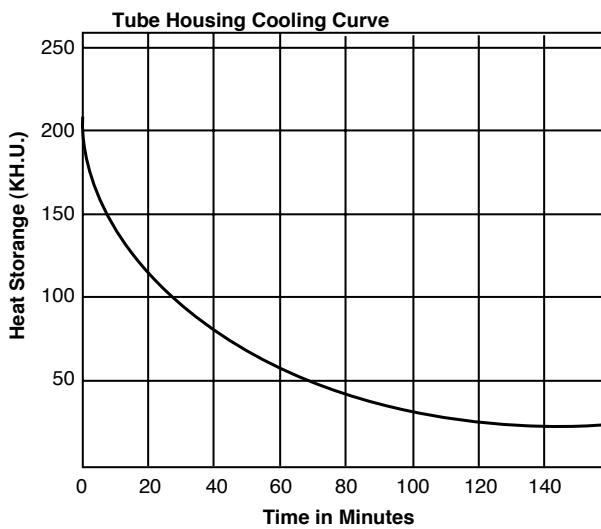

2. Anode thermal characteristics

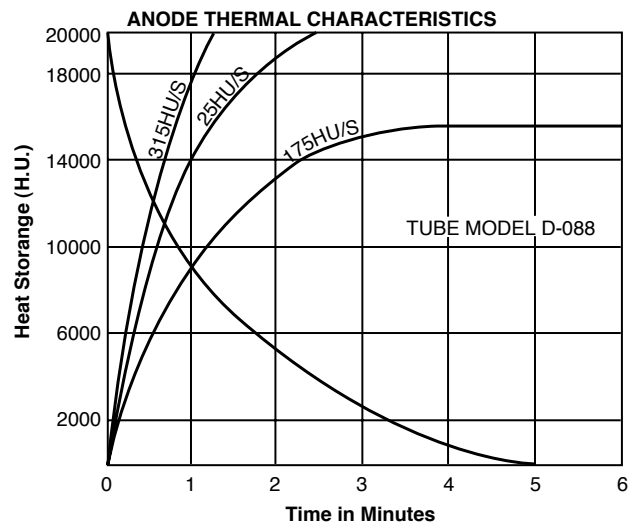

3. Maximum rating chart

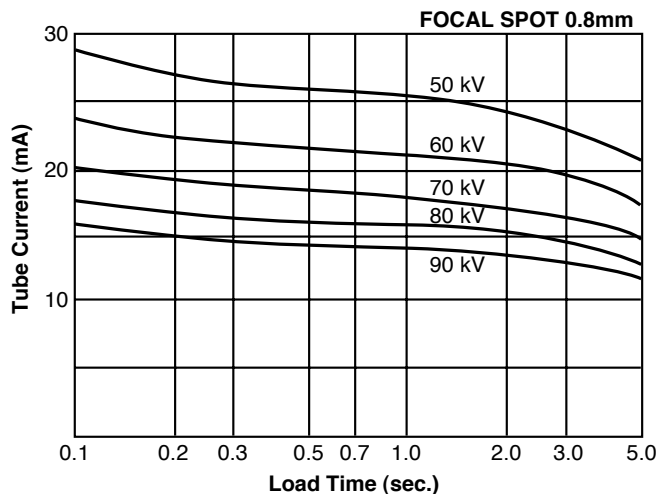

SECTION TWO : PRE-INSTALLATION INSTRUCTIONS

[1] SUPPORT REQUIREMENTS

Control box:

When mounting the model 096 control box, the wall and mounting hardware must be sufficient to withstand a 25 pound shear load.

Arm and head:

The MODEL 096 wall plate is designed for mounting on two 2 x 4 wood studs with 16 inches centers. For other types of construction, the wall and mounting hardware must be sufficient to withstand a 100 pound shear load and a 450 pound withdrawal force at each of the four mounting bolts.

The arm mounting bracket, part No.39, must be mounted to the wall plate using the bolts supplied with the x-ray.

⚠ CAUTION:

If the MODEL 096 is to be mounted in a manner other than what is specified in this manual or if the hardware to be used is other than what is supplied, the support capability of the wall and the strength of the hardware must be checked and verified to be adequate.

[2] ELECTRICAL REQUIREMENTS

Power supply:

The MODEL 096 x-ray system will operate on a power supply of 120V AC,+12V AC,-12V AC (108V AC to 132V AC).

A 3 wire GROUNDED circuit, separately connected to the central distribution panel with an over-current protection device rated for 15 amperes.

Recommended wire size is 12 AWG BUT if the wire run distance is to exceed 50 feet 10 AWG is required. For wire run distances in excess of 75 feet 8 AWG is required. Line voltage regulation must be within 2~5 % at 10.8 amps.

Interconnecting wiring, control box to arm and head assemblies:

6 conductor 12 AWG is recommended for wire run distances up to 50 feet. For wire runs between 50 and 75 feet 10 AWG is required and for wire run distances in excess of 75 feet 8 AWG is required.

Concealed wiring for WK type:

Concealed wiring is accomplished by bringing conduit and wires into (2) flush mounted junction boxes located (1) behind the control box and (1) behind the arm mounting plate. Recommended heights for the flush junction boxes are : 51 5/8" for behind control box and 44 1/2" for behind wall plate. Wiring done in this manner should extend 12 inches beyond the wall surface to allow sufficient wire for connections.

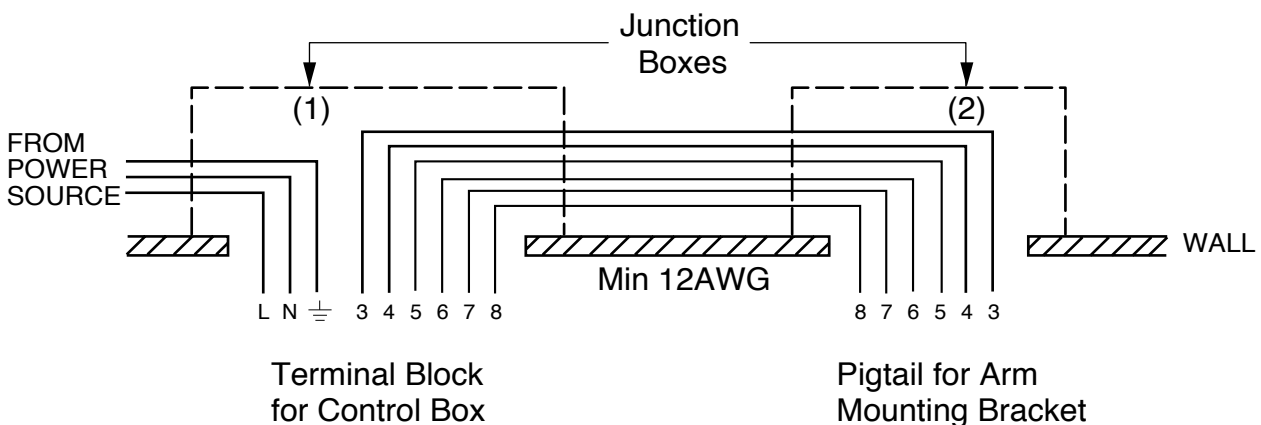

NOTE:

All connections, workmanship and materials used must comply with the local codes.

[3] LOCATION OF COMPONENTS

A. Arm and head assemblies for WK type:

Using the information provided in FIGURE 1, determine the correct location for the installation of the arm and head assemblies.

NOTE: State and local requirements supersede guide lines indicated below.

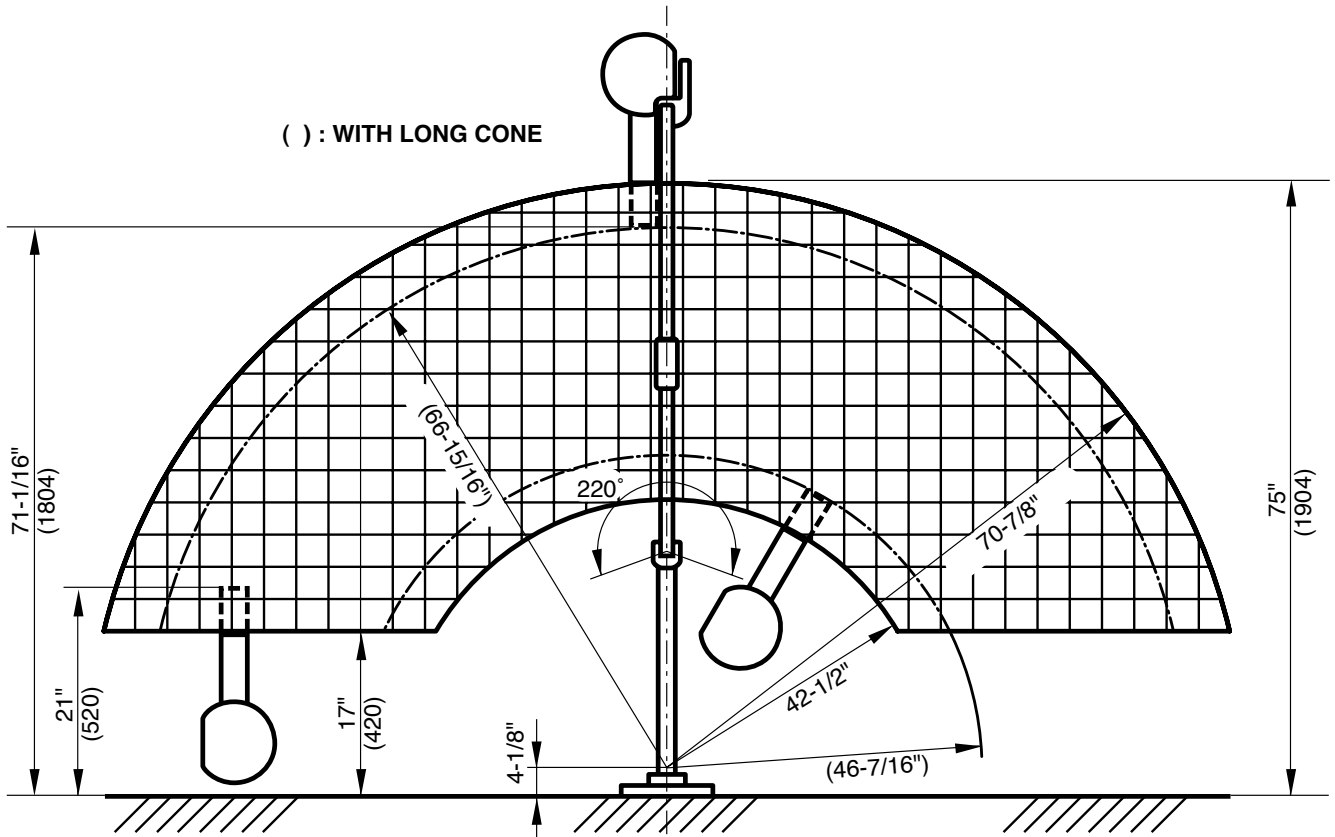

FIGURE 1

B. Control box :

When determining the location for the control box the following radiation requirements concerning operator positioning must be considered. The operator must;

1. have full view of the patient.
2. have full view of kVp, mA, timer selections and exposure warning light.
3. be a minimum of 6 feet away from the patient.
4. be out of line of the useful beam of radiation or be positioned behind a protective device with X-ray protection equivalent of 1 mm of lead.

SECTION THREE : INSTALLATION INSTRUCTIONS

Within the installation and confirmation procedures are inspection/test steps which the installer must perform to insure that the installation meets the manufacturer’s specifications. These steps require the installer to record the necessary information onto the “ASSEMBLER’S INSTALLATION SECTION OF THE LIMITED WARRANTY REPORT FORM” supplied, which must be returned to BELMONT along with the warranty card.

[1] INSTALLATION REQUIREMENTS

Tools:

Standard tool kit including wire crimping pliers (AMP, “Super Champ” or equivalent).
1.5 mm, 2 mm, 3 mm and 5 mm allen keys.

Instruments:

Digital multimeter with an accuracy of 1%, capable of measuring 150 V AC and 10mA DC, and capable of indicating true RMS value within 1 second.

Impulse counter, capable of registering 1 to 999 half-wave primary voltage impulses at a rate of 60 per second over a range of 90 to 100 Vrms, 60 Hz.

Standard calculator.

POWER SUPPLY:

Prior to starting the installation inspect the power supply and confirm that the power supply is 120V AC, +12V AC, -12V AC, and that the supply is a 3 wire GROUNDED circuit, separately connected to the central distribution panel with an overcurrent protection device rated for 15 amperes (Refer to Page 6, [2] ELECTRICAL REQUIREMENTS).

Record the voltage reading of power supply on “Assembler’s Installation Report”.

[2] UNPACKING

Unpack the entire contents of the shipping carton. Included within the shipping carton are:

Identification	Quantity
Head.....	1/WK,RK
Regular Cone.....	1/WK,RK
Long Cone.....	(1)/WK (OPTION)
Control Box.....	1/WK,RK
Head key.....	1/WK,RK
Collar.....	1/WK,RK
Balance Arm.....	1/WK
Balance Arm Wrench.....	1/WK
Horizontal Arm W/ 2/Screw Cover.....	1/WK
Arm Mounting Bracket W/3 Machine Bolt (M8 x 20mm), 3/Bolt cap.....	1/WK
Wall Plate W/4 Coach Bolts, 3 bolts, Washers,7/bolt cap and template.....	(1)/WK
Brake Screw (M6 x 6mm).....	2/WK,RK
Brake Plug (Brass Plug).....	2/WK,RK
Retaining Bolt (M6 x 35mm).....	2/WK
Stopper Screw (M6 x 15mm).....	1/WK,RK
Control Box Mounting Screw (ø5.8 x 32mm).....	4/WK,RK
Brake Spring (ø5).....	1/RK
Base.....	1/RK
Column.....	1/RK
Sliding Post.....	1/RK
Swing Arm.....	1/RK
Gas Pump.....	1/RK
Seat.....	1/RK
Lag Bolt (ø8 x 45mm).....	5/RK
Manual.....	1/WK,RK

Inspect contents of shipping carton for damage or missing components.

[3] ARM ASSEMBLY INSTALLATION

[3-1] WK TYPE

The INSTRUCTIONS given below are for mounting the arm and head assembly on two 2 X 4 wood studs with 16-inch centers. Should the MODEL-096 be mounted in a manner other than what is specified here, the wall and the strength of the hardware used must be checked and verified as being adequate to withstand a 100 pound shear load and a 450-pound withdrawal force at each of the four mounting bolts.

When using concealed wiring, a flush mounted junction box with the necessary conduit and wiring must be pre-installed at 40 5/8 inches from the floor and centered between the two studs (refer to template).

A. WALL PLATE (FIGURE 2):

1. Tape the wall mount plate template to the wall, positioning it so that the holes are aligned with the vertical 2 X 4" stud.

NOTE: In no instance is the wall mount plate, or the arm mounting bracket, to be a single stud.

2. Mark the hole locations.
3. Using a 3/16" drill, drill a pilot hole approximately 2" deep for each plate bolt. **CAUTION:** Do not use larger dia. drill. The electrical wire access hole should be predrilled using the height from the floor specified on the mounting template.
4. Place the wire through the hole into the stud mount wall plate and mount the plate to the stud with 4 coach bolts supplied.

DO NOT FULLY TIGHTEN BOLTS.

5. Holding plate firmly against the wall, place a **level(a)** upright on the surface. If the wall is not plumb, use shims behind the plate to level.
6. Place a **level(b)** across top edge of wall plate, level and tighten bolts securely.
7. Put bolt cap to each head of bolt.

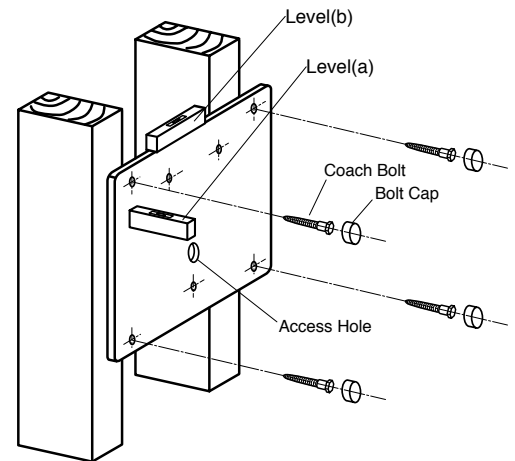

FIGURE 2

B. ARM MOUNTING BRACKET (FIGURE 3):

1. Remove access cover from bottom of arm mounting bracket. Snake electrical interconnecting wires through bracket and out access hole.
2. Using M 8 X 20 mm bolt with washers in lower mounting hole and two M 8 X 20 mm bolts in top mounting holes, mount arm mounting bracket to wall plate. **DO NOT FULLY TIGHTEN.**
3. Placing **level** across top edge of arm mounting bracket, level bracket then tighten bolts securely.
4. Put the bolt cap to each head of bolt.

NOTE: Final leveling of wall mounting bracket is described on Page 13.

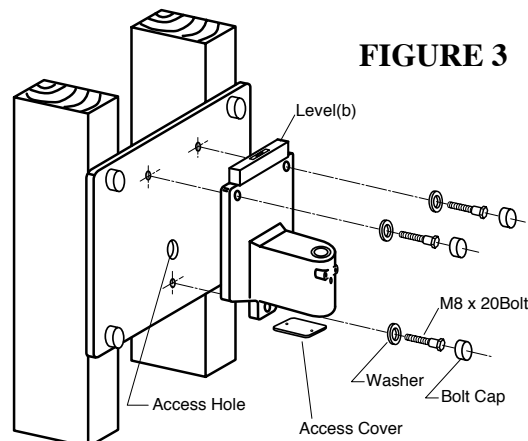

FIGURE 3

- C. If wall plate is not used, other optional, special, wall plate for "pas thru" (4X4") installation must be installed.

D. HORIZONTAL ARM (FIGURE 4):

1. Cut pull string on horizontal arm. **DO NOT REMOVE STRING.** ALLOW ONE END TO EXTEND BEYOND MALE BARB AND THE OTHER END TO EXTEND BEYOND THE FEMALE MOUNT.
2. Place a thrust washer over the hole of arm mounting bracket, and insert male barb into arm mounting bracket, allowing pull string to extend through access opening on bottom of the arm mounting bracket.
3. Insert two retaining bolts securely into upper threaded holes of arm mounting bracket and tighten securely.

⚠IMPORTANT: The retaining bolts must securely engage the annular groove horizontal arm, the removal of the retaining bolts will allow the horizontal arm to rise vertically, and out of, the arm mounting bracket.
DO NOT FULLY TIGHTEN.

4. Insert brake plug then brake screw (M6 x 6mm) into the lower threaded hole of the arm mounting bracket.
5. Place a level on the horizontal arm and confirm that the arm is level in its left and right swing positions.
NOTE: Final leveling of horizontal arm is described on Page 13.

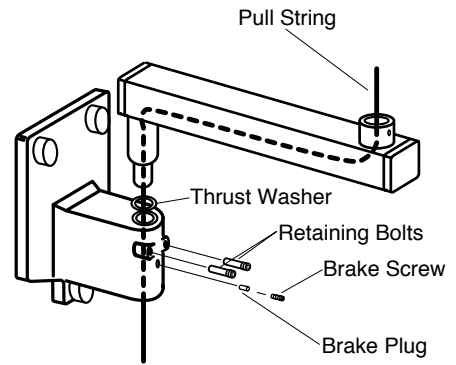

FIGURE 4

E. BALANCE ARM ASSEMBLY (FIGURE 4a):

⚠WARNING:

DO NOT RELEASE ARM HOLDING BAND UNTIL THE X-RAY HEAD HAS BEEN INSTALLED. BALANCE ARM ASSEMBLY IS SPRING LOADED AND CAN CAUSE EQUIPMENT DAMAGE AND INJURY IF NOT HANDLED IN THE PROPER MANNER.

1. **DO NOT REMOVE ARM HOLDING BAND.**
2. Secure pull string to cable and pulling the opposite end, snake cable through horizontal arm and arm mounting bracket.
3. Insert brake plug then brake screw (M 6 X 6 mm) into the horizontal arm collar.
DO NOT FULLY TIGHTEN.
4. Remove end cap screw and open end cap.
5. Insert stopper screw into upper threaded hole inside horizontal arm and tighten securely.

6. **⚠CAUTION:** If stopper screw is not tightened securely, the scissors arm can move vertically up and out of the horizontal arm
6. Cut cable and interconnecting wires to a workable length. Strip 3/8" of wire insulation from each lead. With wire crimping pliers use supplied wire nuts to make wire connections.
7. Insert connected wires into the arm mounting bracket and secure the access cover to the bottom of the arm mounting bracket.
8. Secure end cap with end cap screw, and place a screw cover.

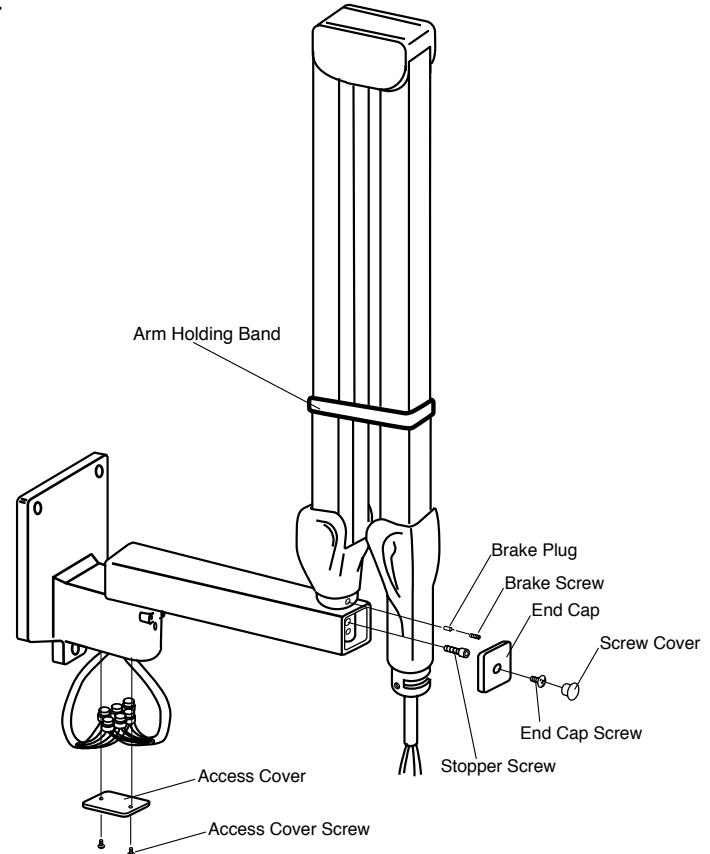

FIGURE 4a

[3-2] RK TYPE (FIGURE 5)

1. Fix the base on the floor with lag bolts (supplied) or with appropriate means.

**▲ CAUTION :MAKE SURE THE BASE IS
FIXED ON THE FLOOR FIRMLY.**

2. Insert the sliding post with column cover into the column.
3. Install the column on the base with mounting bolts. Make it vertical with adjusting bolts.
4. Put the thrust washer to top of the sliding post and install the swing arm assembly to sliding post.
5. Set the stopper screw into lower threaded hole of swing arm 2.
6. Set the brake plug then brake spring and brake screw into the upper hole of swing arm 2. Tighten the brake screw IF ARM DRIFTS. **DO NOT FULLY TIGHTEN.**
7. Run the cable from swing arm 1 through a cable guide.
8. Slide up the backrest cushion to the top of column.
9. Insert the gas pump into the gas pump bracket. Mount the seat on the gas pump.
10. Refer to page 12 for Head assembly installation.
11. Refer to page 13 for Control box installation.
12. Perform the post installation inspection.(page 14)

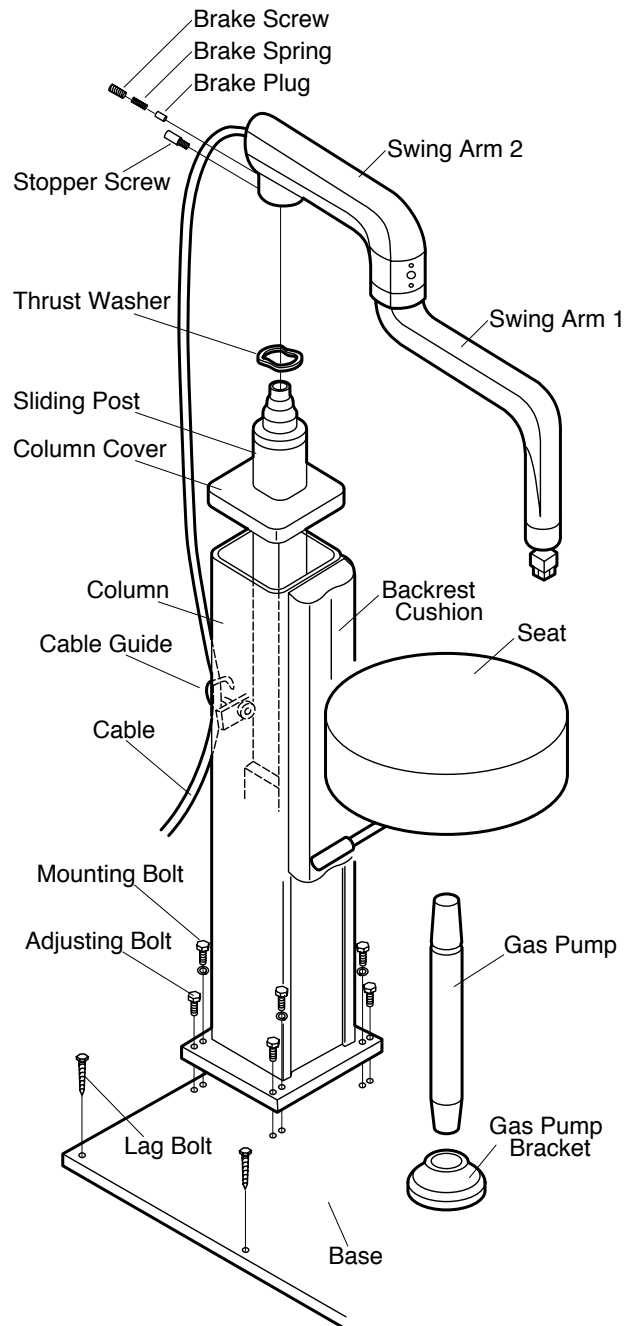

FIGURE 5

[4] HEAD ASSEMBLY INSTALLATION (FIGURE 6):

1. Remove a screw (a) on arm collar, and place the arm collar over the stopper ring on the head shaft.
(Direction of arm collar is shown in FIGURE 6.)
2. Remove the yoke inside cover by loosening screw(b).
3. Making sure the stopper ring and arm collar is placed on the head shaft, insert the wirings of balance arm through the head shaft to the head yoke.
4. Insert the head shaft into balance arm assembly, and while holding the head in position, install head key securely into retaining groove.
5. Slide the arm collar upward to proper position and secure it in place with a screw (a).
6. Loosen 5 screws on the terminal using a small dia. screw driver, and insert the wirings of balance arm assembly into the terminal according to the color. (FIGURE 6-1)
7. Retighten the screws on the terminal and confirm that the wirings are fixed on the terminal.
8. Remove M5 Phillips head screw from earth terminal and secure No.8 wiring together to earth terminal.
9. Reattach the yoke inside cover with a screw.
10. Remove arm holding band.

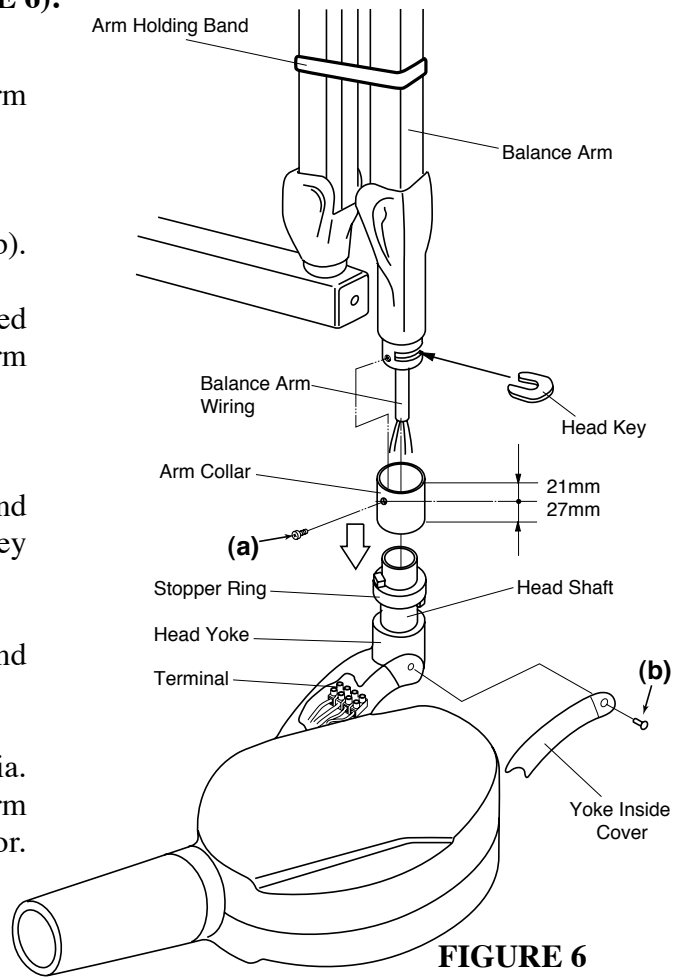

FIGURE 6

3	Blue
4	Brown
5	Red
6	Yellow
7	Gray
8	Green/Yellow

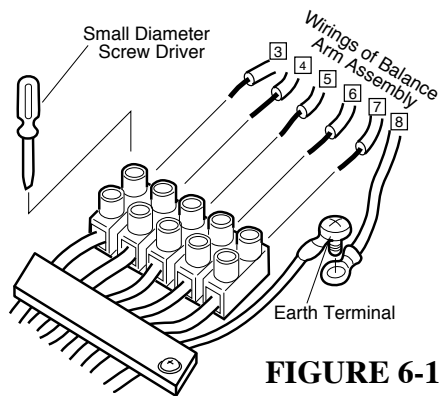

FIGURE 6-1

[5] CONTROL BOX INSTALLATION

The wall and the strength of the hardware used must be checked and verified as being adequate to withstand a 25 pound shear load.

A flush mounted junction box with the necessary conduit and wiring must be pre-installed at 51 5/8" from the floor.

NOTE: Refer to the control box template, and:

1. Be certain the electrical wire entry hole is aligned with the junction box.
2. That there is adequate support in the wall to secure the control box.

A. CONTROL BOX - MOUNTING (FIGURE 7):

1. Tape the control box template to the wall at the recommended height.
 - 1a. Confirm relationship of access hole in for the electric wires with the entry hole for the wires in the back of the control box.
2. Using a 3/32" drill, drill a pilot hole 2" deep for each mounting screw.
 - 2a. The method of drilling the pilot hole and, the hardware use to secure the control box depend upon the structure.
3. Drive two wood screws into upper two holes remaining about 3/4" undriven. (Fig.7a)
4. Remove two M3 Phillips head screws from top of the control box and open front panel. (Fig.7b)
5. Remove a restriction plate. (Fig.7c)
6. Snake power supply cable lines and interconnecting wires through access hole in back panel.
7. Hook the control box chassis to wood screws driven in step 3 above through two mounting holes on upper side of chassis. Tighten screws slightly.
8. Attach two wood screws to mounting holes on lower side of back panel. (Do not fully tighten.) (Fig.7d)
9. Placing level across top edge of the control box, level, then tighten four screws securely.

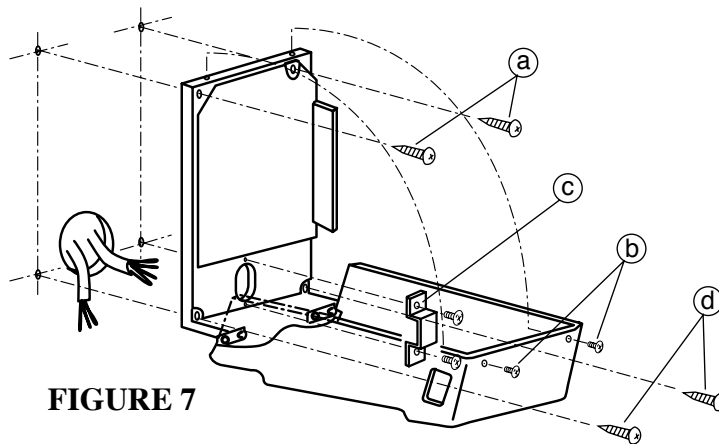

FIGURE 7

B. CONTROL BOX, WIRING (FIGURE 8-a & 8-b)

⚠WARNING: MAKE SURE THE POWER SUPPLY IS TURNED OFF AT THE CENTRAL DISTRIBUTION PANEL.

1. Strip approximately 3/8" of insulation off the power supply leads and interconnecting cables.
2. Following wiring diagram, connect those wires to the terminal block of control box.
3. Set the restriction plate to the original place.

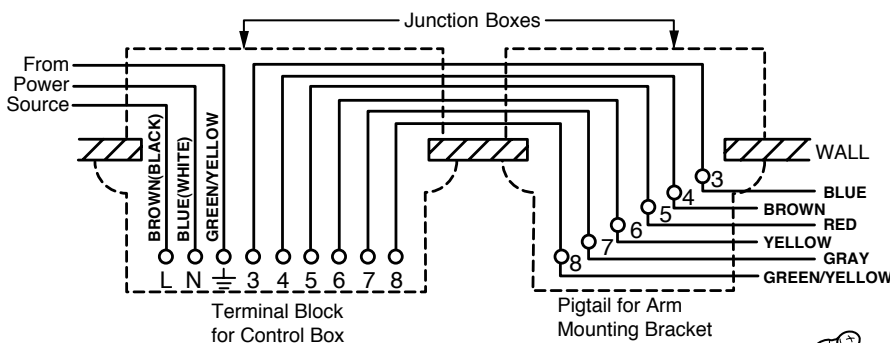

FIGURE 8-a

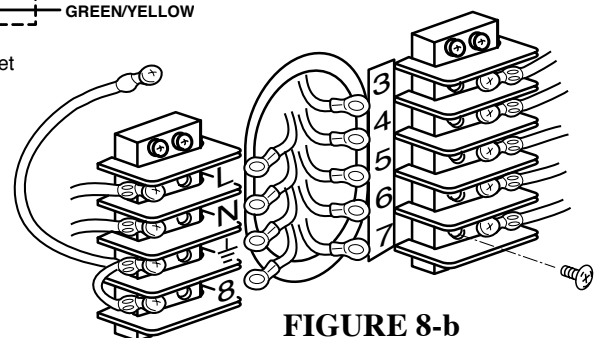

FIGURE 8-b

C. CLOSING FRONT PANEL (FIGURE 9).

⚠ CAUTION: BEFORE CLOSING THE FRONT PANEL, PERFORM POST INSTALLATION CONFIRMATION (PAGE 20).

1. Confirm all the post installation confirmation are performed.
2. Close the front panel and secure two M3 phillips head screws on the top panel.

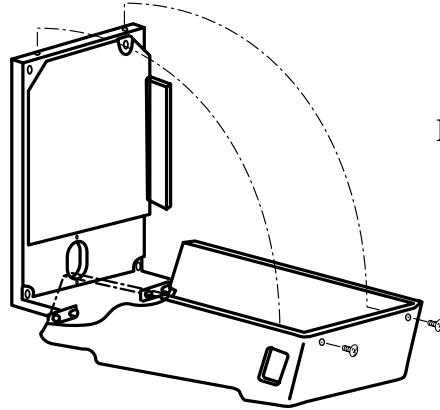

FIGURE 9

SECTION FOUR: POST INSTALLATION INSPECTION

[1] ARM ASSEMBLY

1. Incorrect levelling of the wall bracket can cause arm drift. First, check level with arms in position #1 . If not correct, bracket must be adjusted by placing shims behind the wall plate (FIGURE 10-a).

IMPORTANT:

If the end of the horizontal arm #1 is pitched below level, then the tubehead will drift away from the wall. If the end of the horizontal arm #1 is pitched above level, then the level arm will require only minimum adjustment of brake (friction) screw.

2. Check level in position #2. If not correct, adjust as follows: (FIGURE 10-b)
 - a) Remove bolt caps on mounting bolts.
 - b) SLIGHTLY loosen two top mounting bolts.
 - c) Shift the bracket left or right up to the arms arc accurately levelled.
 - d) Move the horizontal arm to position #1.
 - e) Fully tighten two top mounting bolts.
 - f) Fully tighten bottom mounting bolt.
 - g) Put the bolt cap to each head of mounting bolt.

NOTE: SLIGHT TENDENCIES TO DRIFT CAN BE CORRECTED BY TIGHTENING BRAKE SCREWS IN HORIZONTAL ARM AND/OR WALL BRACKET. DO NOT TIGHTEN BEYOND WHAT IS REQUIRED TO PREVENT DRIFT.

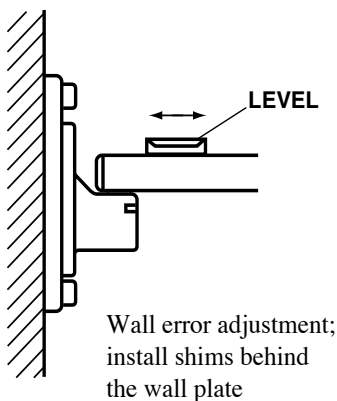

FIGURE 10-a

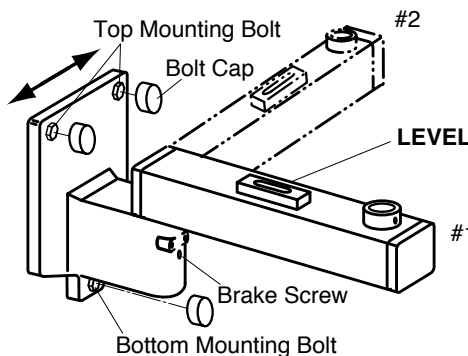

FIGURE 10-b

[2] BALANCE ARM ASSEMBLY

1. Place the balance arm assembly into position.
2. If either balance arm drifts either higher or lower from the set position, remove the spring adjuster covers and with the supplied wrench adjust the balance arm springs (FIGURE 11).

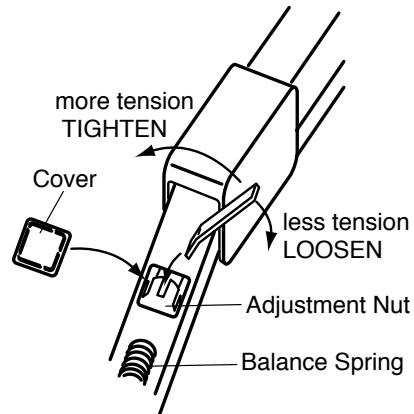

FIGURE 11

[3] HEAD POSITIONING

- A. Place head into position.
- B. If head drifts from the set position, adjust the brake screws according to the following procedures. (FIGURE 12)
 1. Remove the yoke outside cover by loosening cover screw.
 2. Adjust 6 brake screws using phillips screw driver.
 3. After adjustment, reattach the yoke outside cover with the cover screw.

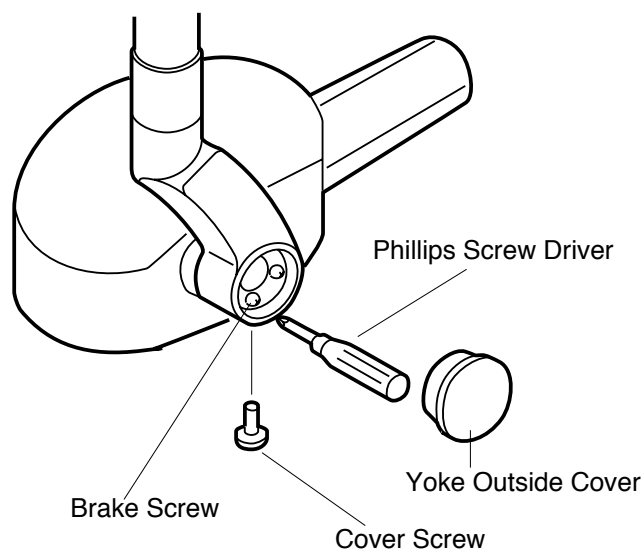
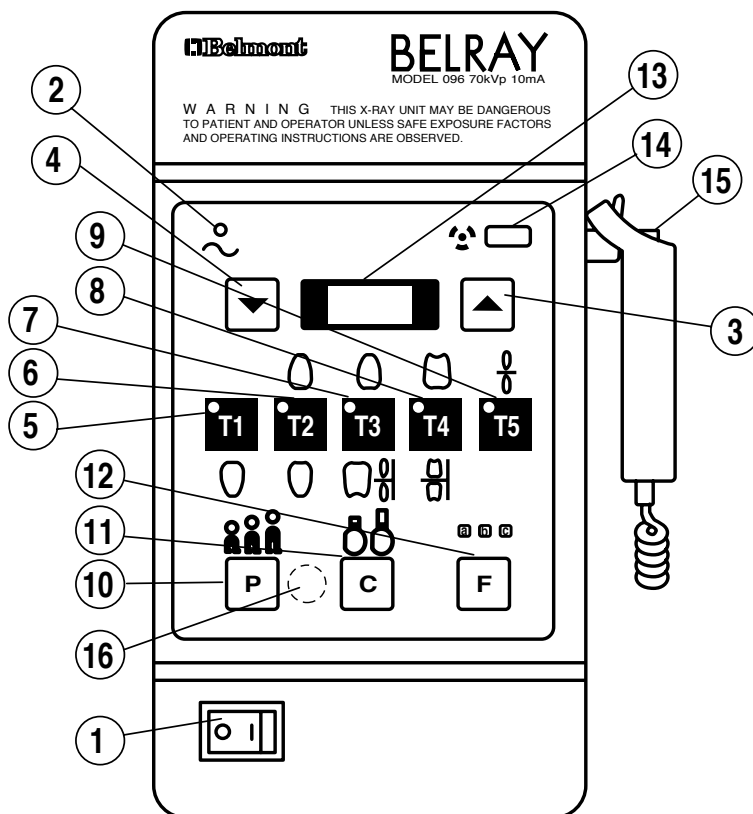

FIGURE 12

SECTION FIVE : CONTROL IDENTIFICATION AND OPERATION

[1] CONTROL IDENTIFICATION



- (1) Main Power switch
- (2) Ready Lamp
- (3) Exposure Time Adjusting Sw. (Up)
- (4) Exposure Time Adjusting Sw. (Down)
- (5) Tooth Selection Switch (T1)
- (6) Tooth Selection Switch (T2)
- (7) Tooth Selection Switch (T3)
- (8) Tooth Selection Switch (T4)
- (9) Tooth Selection Switch (T5)
- (10) Patient Size Selection Switch
- (11) Cone Type Selection Switch
- (12) Film Speed Selection Switch
- (13) Exposure Time Display Window
- (14) Exposure Warning Light
- (15) Exposure Switch
- (16) Technical Switch

[2] FUNCTION OF CONTROLS

- ① **Main Power switch**
Pushing right side of this switch energizes the x-ray unit.
(Ready lamp and pre-selected lamps for patient size, cone type and film speed illuminates.)
It is recommended to keep this switch OFF when the unit is not in use in order to prevent an accidental exposure.
- ② **Ready Lamp**
This lamp lights when the line voltage is within operable range.
When this lamp is not on, exposure can not be made.
- ③④ **Exposure Time Adjusting Switches**
By momentarily pushing ▲ (or ▼) switch, exposure time displayed increases (or decreases) by one step. By keeping the switch depressed more than 2 sec., exposure time displayed increases (or decreases) continuously until the switch is released.
- ⑤~⑨ **Tooth Selection Switch (T1 ~ T5)**
Pushing one of these switches set the exposure time automatically in combination with following ⑩~⑫.
- ⑤ T1 : Incisor of Mandible
- ⑥ T2 : Incisor of Maxilla, Cuspid & Premolar of Mandible
- ⑦ T3 : Cuspid & Premolar of Maxilla, Molars of Mandible, Bitewing
- ⑧ T4 : Molars of Maxilla, Bitewing Molars
- ⑨ T5 : Occlusal

⑩ Patient Size Selection Switch

Pushing this switch alters the selection of patient size (small -> medium ->large -> small) and sets the exposure time accordingly.

⑪ Cone Type Selection Switch

The exposure time corresponding to the cone type being used (Standard Regular Cone or Optional Long Cone) can be selected by this switch.

⑫ Film Speed Selection Switch

Three types of film speed can be registered. Pushing this switch momentarily indicates the film speed number being selected in exposure time display window ⑬.

Depressing the switch for more than 2 seconds alters the film type being selected.

NOTE : Setting or adjusting the exposure time manually (with ▲ or ▼ switch) supersedes ⑤~⑫ functions.

⑬ Exposure Time Display Window

Normally the exposure time selected is displayed.

1. E.00 ~ E.12 :Error code [See page 19 of this manual]
2. F.00 ~ F.15 :Film type [See page 21 & 22 of this manual]
3. Tube Current: The tube current of the last pulse of the exposure can be displayed if the exposure switch is kept depressed after exposure is over and technical switch ⑯ is depressed.
4. bu.0, bu.1 :Buzzer ON/OFF when a switch is activated. [See page 23 of this manual]
5. FI n :Confirmation of tube current [See page 20 of this manual]
6. PH.0 ~ PH.F :To adjust tube current at beginning of exposure [Refer to service manual]
7. EP.0 ~ EP.F :To adjust tube current when stabilized [Refer to service manual]
8. Pt.0 ~ Pt.F :To adjust preheat time [Refer to service manual]

⑭ Exposure Warning Light

Illumination of this light indicates the unit is producing x-radiation.

⑮ Exposure Switch

Deadman Type exposure switch. When making an exposure, depress this switch and keep it depressed until the exposure warning light ⑭ and the audible warning terminate.

Failure to keep this switch depressed will result in premature termination of the exposure.

⑯ Technical Switch

This switch is exclusively for the installer and service personnel. It is used for following purposes:

1. The tube current (mA) of the last pulse of the exposure can be displayed in exposure time display window ⑬ if the exposure switch is kept depressed even after the exposure is over and this technical switch is depressed. Display will return to exposure time when the exposure switch is released.
2. Priority of selection (Patient Size, Cone Type, Film Speed) can be changed when the main power switch is turned on while this switch is depressed. [See section Seven of this manual]
3. Memorizing : After setting film speed, priority of selection and/or buzzer ON/OFF, this switch is used for memorize these settings. [See section Seven of this manual.]

[3] OPERATING PROCEDURES

1. Turn ON the main power switch (1).
2. Confirm that ready lamp (2) is illuminated.
NOTE: The ready lamp will not illuminate unless the incoming line voltage is correct and within the x-ray's operable range.
3. Select the appropriate tooth type (5~9), and confirm if the pre-selected conditions (patient size (10), cone type (11) and film speed (12)) are suitable for radiographing.

NOTE: To manually set the exposure time, depress either manual exposure time adjust switch (3 ▲ or 4 ▼) until the desired exposure time is displayed in exposure time display window (13). While the unit is in manual mode, other selection switches (5~12) do not affect exposure time. (All the tooth selection lamps are off.)

To return to the automatic exposure time selection mode, depress any one of tooth selection switches.

4. Depress the exposure switch (15). When the exposure switch is depressed, the exposure warning lamp (14) illuminates and the audible warning sounds. Do not release the exposure switch until the audible warning and the warning lamp terminate. Failure to keep the switch depressed will result in the exposure being terminated prematurely.
5. To continue to radiograph other teeth, just select appropriate tooth selection switch.

**IMPORTANT : To protect x-ray tubehead from heat accumulation, wait for 60 times of exposure time between exposures.
[Ex. 30 second wait interval for each 0.5 sec.(30 impulses) exposure]**

6. After use turn OFF the main power switch (1) in order to prevent accidental exposures.

NOTE : If the unit is left over 8 minutes without being operated and the main power switch is kept on, figure 1 runs through the exposure time display window. This does not mean that a malfunction of the unit has occurred, but saves energy. The unit returns to normal condition by pressing any one of the switches except the exposure switch.

[4] **ERROR CODES**

When abnormal condition exists in the unit, or malfunction occurs, error code is displayed in exposure time display window.
Please refer to the table below.

Error code	Condition	Step to be taken	Possible solution
E.00	Exposure switch was released before the exposure terminates.	All the tooth selection switches blink. Depress one of the switch.	Release exposure switch after exposure lamp turns off.
E.01	Exposure switch was depressed within 10 sec. of previous exposure.	A 10 second delay is built in between each exposure. Release exposure switch.	There is to be an "wait" interval of 60 times of exp. time between successive exposures.
	Exposure switch was depressed within 3sec. after the main power switch has been turned on.		Exposure switch should be depressed after the ready lamp comes ON.
E.02	Line voltage was less than 90% of rated voltage.		If line voltage is less than 90% of rated line voltage, correct it by using step-up transformer.
E.03	Line voltage was more than 110% of rated voltage.		If line voltage is more than 110% of rated line voltage, correct it by using step-down transformer.
E.04	Excess current during exposure.	Turn off the main power switch and wait for a while. Turn on the main power switch again.	Conduct the confirmation of tube current described in section six, item[2]on page 20.
E.05	Tube current of the last pulse was less than 7.5mA.		
E.06	Tube current of the last pulse was more than 12.5mA.		
E.07	Tube current during exposure was less than 5mA.		
E.08	Tube current during exposure was more than 15mA.		
E.09	Malfunction of the microcomputer.		
E.10	Exposure switch or exposure circuit had been ON, when main power switch is turned on.		
E.11	Tube current is detected during pre-heating period.		
E.12	Tube current is detected when main power switch is turned on.	Refer to the service manual.	

SECTION SIX : POST INSTALLATION CONFIRMATION

[1] CONFIRMATION OF POWER SUPPLY VOLTAGE

As specified in Electrical Requirements (Page 6), power supply voltage must be within the operable range of 108~132V AC. Confirm the power supply voltage again before turning on the unit.

1. Open the front panel of control box by loosening two screws on top of the control box.
2. Set the range of digital multi meter at 200V AC, connect probes of multimeter to L and N of terminal block of control box.
3. Confirm that the reading is $120V \pm 10\%$ (108~132V AC).

NOTE : 096 X-ray can not be operated unless the power supply voltage is within this range.

[2] CONFIRMATION OF TUBE CURRENT

Model 096 x-ray incorporates self diagnose system to check if the tube current is within specified range both at the beginning of exposure and during stabilized period.

1. While depressing tooth selection switches T1, T4 & T5 together, turn on the main power switch.
2. Exposure time of 0.50 is displayed and ready light is on.

[If not, turn off main power switch and repeat 1.]

Then release T1, T4 & T5 switches.

3. Make an exposure by depressing hand exposure switch.

▲ WARNING: X-RADIATION IS GENERATED FOR 0.5 SEC.

4. Confirm that "F I n" is displayed at exposure time display window.

Then, turn off the main power switch.

5. If "PH. ○" and "EP. ○" are displayed alternately, follow Step 6 through 8 below.

6. When "PH. ○" and "EP. ○" are displayed alternately, leave the unit for about 30 seconds until display returns to "0.50". Then make an exposure again and confirm that "F I n" is displayed.

7. Repeat Step 5 & 6 until "F I n" is displayed.

8. Record final PH & EP values in "Assemblers Installation Section of Limited Warranty Report Form" if procedures in Step 5 through 7 are performed.

[3] CONFIRMATION OF EXPOSURE WARNING LAMP & BUZZER

A. EXPOSURE WARNING BUZZER

1. Make an exposure and confirm that the exposure warning buzzer located within the control box is activated during the entire exposure.

B. EXPOSURE WARNING LAMP

Exposure warning lamp is located on the front panel of the control box,

1. Make an exposure and confirm that the warning lamp illuminates during the exposure.

[4] CONFIRMATION OF LINE VOLTAGE REGULATION

1. Make sure that main power switch is "OFF".

2. Open the front panel of control box by loosening two screws on top of the control box.

3. Set the range of digital multi meter at 200V AC, connect probes of multimeter to L and N of terminal block of control box.

4. Turn the main power switch on, and set the exposure time at 2.00 sec. with manual switch ▲.

5. Record the no-load line voltage (VN) indicated by the multimeter before exposure.

6. Make an exposure and record the load voltage (VL) indicated by the multimeter during exposure.

▲ WARNING : X-RADIATION IS GENERATED FOR 2 SECONDS.

NOTE: Read the multimeter when the value is stabilized (about one second after exposure).

7. Calculate line voltage regulation R (%) in the formula below:

$$R = \frac{VN - VL}{VL} \times 100 \quad \text{Record this value in "Assemblers Installation Report".}$$

NOTE: LINE VOLTAGE REGULATION MUST NOT EXCEED THE RANGE OF 2~5%.

IF IT IS GREATER THAN 5%, THE SIZE OF THE POWER SUPPLY WIRES MUST BE INCREASED. REFER TO THE POWER SUPPLY REQUIREMENTS OUTLINED ON PAGE 5 TO DETERMINE THE CORRECT WIRE SIZE NECESSARY.

SECTION SEVEN : INITIAL SETTING

[1] **FILM SPEED**

As factory installation, following three kinds of film speed are registered to be selected by Film Speed Selection Switch :

a = Film speed No. F.09 (equivalent to ISO speed group "D", or Kodak Ultra-Speed film)

b = Film speed No. F.04 (equivalent to ISO speed group "F/E", or Kodak InSight film)

c = Film speed No. F.02 (equivalent to ISO speed group "F")

Including these three, Model 096 can provide 16 different types of film speed and any three of them can be registered for easy selection.

If the doctor uses different speed of film, or prefers darker (or lighter) radiograph, substitute speed can be registered as follows:

1. While depressing technical switch (16), turn on the main power switch (1). Film type lamp "a" is lit, and F.09 is displayed in exposure time display window (13).
Then, release technical switch.
2. By depressing ▲ switch (or ▼ switch), increase (decrease) film speed number until desired number is displayed. [Refer to Exposure Time Table on next page.]
3. Depress technical switch (16), an electronic chime sounds and the selected film speed number is registered at film type "a".
4. Turn off the main power switch.
5. If different film speeds are to be registered at "b" and "c", depress "F" switch (12) after step 1 above to light the appropriate film type lamp, and repeat steps 2 & 3.

TABLE 1 : FILM SPEED AND EXPOSURE TIME (REGULAR CONE)**(UNIT : SEC.)**

Patient Size	SMALL					MEDIUM					LARGE				
	Tooth	T1	T2	T3	T4	T5	T1	T2	T3	T4	T5	T1	T2	T3	T4
F. 00	0.02	0.03	0.04	0.05	0.07	0.03	0.05	0.06	0.08	0.12	0.04	0.06	0.08	0.10	0.15
F. 01	0.02	0.04	0.05	0.06	0.09	0.04	0.06	0.07	0.10	0.15	0.05	0.08	0.09	0.13	0.18
F. 02	0.03	0.05	0.06	0.07	0.11	0.05	0.08	0.09	0.12	0.18	0.06	0.10	0.11	0.15	0.22
F. 03	0.03	0.06	0.06	0.09	0.13	0.05	0.09	0.10	0.15	0.20	0.06	0.11	0.13	0.18	0.25
F. 04	0.04	0.07	0.08	0.10	0.16	0.06	0.11	0.13	0.17	0.25	0.08	0.14	0.16	0.20	0.31
F. 05	0.05	0.08	0.10	0.13	0.19	0.08	0.13	0.16	0.20	0.31	0.10	0.16	0.19	0.25	0.38
F. 06	0.06	0.10	0.12	0.16	0.22	0.09	0.16	0.19	0.25	0.36	0.11	0.19	0.24	0.31	0.44
F. 07	0.07	0.12	0.14	0.18	0.27	0.11	0.19	0.22	0.29	0.44	0.14	0.24	0.27	0.36	0.54
F. 08	0.08	0.14	0.17	0.22	0.33	0.14	0.22	0.27	0.36	0.54	0.17	0.27	0.33	0.44	0.66
F. 09	0.10	0.17	0.20	0.27	0.38	0.16	0.27	0.33	0.44	0.62	0.19	0.33	0.41	0.54	0.76
F. 10	0.12	0.19	0.24	0.31	0.47	0.19	0.31	0.38	0.50	0.76	0.24	0.38	0.47	0.62	0.93
F. 11	0.15	0.24	0.29	0.38	0.54	0.24	0.38	0.47	0.62	0.87	0.29	0.47	0.58	0.76	1.07
F. 12	0.17	0.29	0.33	0.47	0.66	0.27	0.47	0.54	0.76	1.07	0.33	0.58	0.66	0.93	1.32
F. 13	0.20	0.33	0.41	0.54	0.81	0.33	0.54	0.66	0.87	1.32	0.41	0.66	0.81	1.07	1.62
F. 14	0.24	0.41	0.50	0.66	0.93	0.38	0.66	0.81	1.07	1.51	0.47	0.81	1.00	1.32	1.86
F. 15	0.29	0.50	0.58	0.76	1.15	0.47	0.81	0.93	1.23	1.86	0.58	1.00	1.15	1.51	2.28

(UNIT : SEC.)

Patient Size	SMALL					MEDIUM					LARGE				
	Tooth	T1	T2	T3	T4	T5	T1	T2	T3	T4	T5	T1	T2	T3	T4
F. 00	0.05	0.07	0.08	0.11	0.16	0.07	0.11	0.14	0.18	0.25	0.08	0.14	0.17	0.22	0.31
F. 01	0.05	0.08	0.10	0.14	0.19	0.08	0.14	0.16	0.22	0.31	0.10	0.17	0.19	0.27	0.38
F. 02	0.06	0.10	0.12	0.16	0.24	0.10	0.17	0.19	0.25	0.38	0.12	0.20	0.24	0.31	0.47
F. 03	0.07	0.12	0.14	0.19	0.27	0.11	0.19	0.22	0.31	0.44	0.14	0.24	0.27	0.38	0.54
F. 04	0.08	0.15	0.17	0.22	0.33	0.14	0.24	0.27	0.36	0.54	0.17	0.29	0.33	0.44	0.66
F. 05	0.10	0.17	0.20	0.27	0.41	0.17	0.27	0.33	0.44	0.66	0.20	0.33	0.41	0.54	0.81
F. 06	0.12	0.20	0.25	0.33	0.47	0.19	0.33	0.41	0.54	0.76	0.24	0.41	0.50	0.66	0.93
F. 07	0.15	0.25	0.29	0.38	0.58	0.24	0.41	0.47	0.62	0.93	0.29	0.50	0.58	0.76	1.15
F. 08	0.18	0.29	0.36	0.47	0.71	0.29	0.47	0.58	0.76	1.15	0.36	0.58	0.71	0.93	1.41
F. 09	0.20	0.36	0.44	0.58	0.81	0.33	0.58	0.71	0.93	1.32	0.41	0.71	0.87	1.15	1.62
F. 10	0.25	0.41	0.50	0.66	1.00	0.41	0.66	0.81	1.07	1.62	0.50	0.81	1.00	1.32	2.00
F. 11	0.31	0.50	0.62	0.81	1.15	0.50	0.81	1.00	1.32	1.86	0.62	1.00	1.23	1.62	2.28
F. 12	0.36	0.62	0.71	1.00	1.41	0.58	1.00	1.15	1.62	2.28	0.71	1.23	1.41	2.00	2.80
F. 13	0.44	0.71	0.87	1.15	1.73	0.71	1.15	1.41	1.86	2.80	0.87	1.41	1.73	2.28	3.00
F. 14	0.50	0.87	1.07	1.41	2.00	0.81	1.41	1.73	2.28	3.00	1.00	1.73	2.13	2.80	3.00
F. 15	0.62	1.07	1.23	1.62	2.44	1.00	1.73	2.00	2.62	3.00	1.23	2.13	2.44	3.00	3.00

[2] PRIORITY OF SELECTION

As factory installation, following selection lamps light when the main power switch is turned on:

Patient Size : Medium
 Cone : Regular
 Film Speed : "a"

If necessary, this priority can be changed as follows;

[For example, at pedodontistry, patient size of "small" should be preferentially selected.]

1. While depressing technical switch (16), turn on the main power switch.
2. Select the patient size "small" by depressing patient size selection "P" switch (10).
3. Depress technical switch (16), an electronic chime sounds and the patient size of "small" will be stored as primary selection.
4. Priority of selection for cone type and film speed can be changed by same procedures.

[3] ELECTRONIC CHIME ON/OFF

As factory installation, electronic chime sounds when each switch is depressed. If preferred, this sound can be eliminated.

1. While depressing tooth selection switches T1 & T2 together, turn on the main power switch.
2. "bu.1" will be displayed in exposure time display window (13).
3. By depressing either ▲ or ▼ ((3) or (4)), display changes to "bu.0".
4. Then depress technical switch (16), and turn off the main switch.

NOTE : Exposure Warning Buzzer and alarm sound of error code can not be eliminated.

APPENDIX ONE : CIRCUIT DIAGRAM

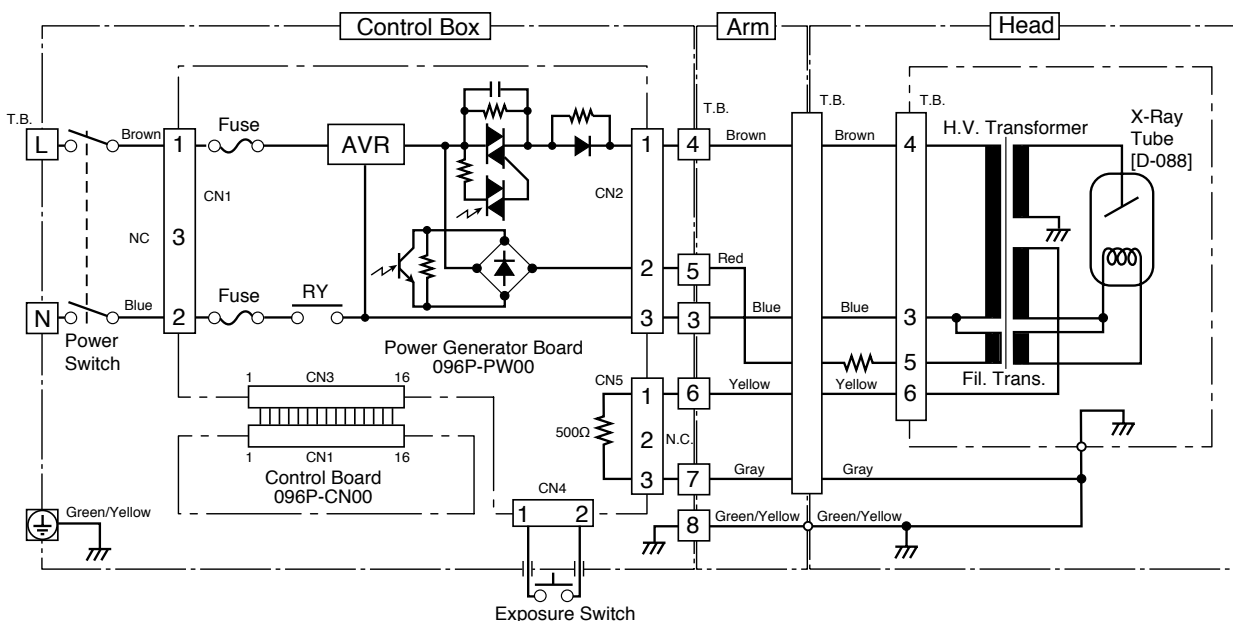

APPENDIX TWO : PARTS IDENTIFICATION

[1] **ARM AND HEAD ASSEMBLY OF WK TYPE**

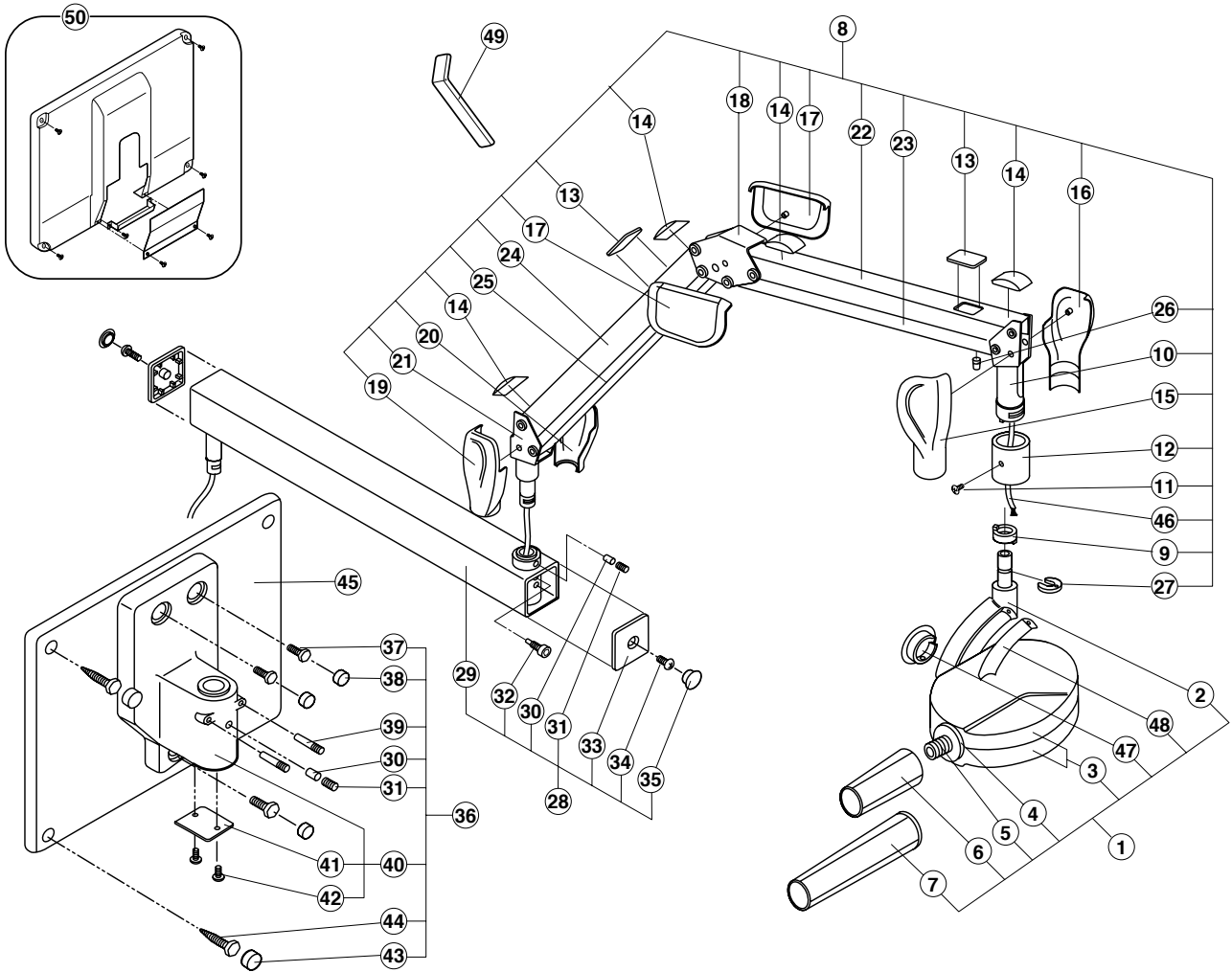

[2] **CONTROL BOX ASSEMBLY (60)**

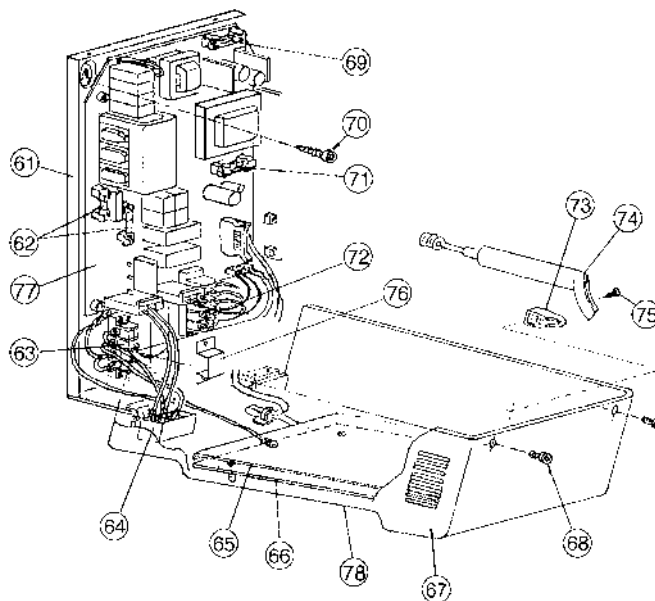

ID.No.	PartsNo.	Description	QTY	USA Code
1	E04-EHLL03A0	X-Ray Head Assembly (RAL-9003)	1	096-1010
2	E04-ECPE03G0	Yoke (RAL-9003)	1	096-1020
3	E04-EHLL12A0	Housing Cover Set (RAL-9003)	1	096-1030
4	E04-ECPR22B0	Lock Ring (R1-1005)	1	096-1040
5	E04-ECPR36A0	X-Ray Exposure Sleeve	1	096-1050
6	E04-ECPR21D0	Regular Cone (RAL-9003)	1	096-1060
7	E04-EHLL13A0	Long Cone (RAL-9003) (Option)	(1)	096-1070
8	E04-EHLL28A0	Balance Arm Assembly (RAL-9003)	(1)	096EHLL28A0
9	E04-ECLS01A0	Stopper Ring	1	096-1090
10	E04-ECPE17B0	Joint No.3	1	096ECPE17B0
11	E04-----	Collar Screw (SUS M4-10)	1	096SRWM0410
12	E04-ECQR34B0	Collar (R1-1005)	1	096ECQR34B0
13	E04-ECQR30C0	Spring Adjuster Cover	2	096ECQR30C0
14	E04-ECQR27B0	Crevice Cover	4	096ECQR27B0
15	E04-ECPE19F0	Left Cover for Joint No.3	1	096ECPE19F0
16	E04-ECPE18F0	Right Cover for Joint No.3	1	096ECPE18F0
17	E04-ECPJ64C0	Cover for Joint No.2	2	096ECPJ64C0
18	E04-ECPJ58B0	Joint No.2	1	096ECPJ58B0
19	E04-ECPJ63F0	Left Cover for Joint No.1	1	096ECPJ63F0
20	E04-ECPJ62F0	Right Cover for Joint No.1	1	096ECPJ62F0
21	E04-ECPE15B0	Joint No.1	1	096ECPE15B0
22	E04-ECPJ60A0	Arm Cover No.2	1	096ECPJ60A0
23	E04-ECPE30B0	Balance Arm No.2	1	096ECPE30B0
24	E04-ECPJ59A0	Arm Cover No.1	1	096ECPJ59A0
25	E04-ECPE31B0	Balance Arm No.1	1	096ECPE31B0
26	E04-ECQR33A0	Cushion Absorber	1	096ECQR33A0
27	E04-ECLR95B0	Head Key	1	096-1270
28	E04-EHLK90A0	Horizontal Arm Ass'y (800mm) (RAL-9003)	(1)	096-1280
	E04-EHLK87A0	Horizontal Arm Ass'y (300mm) (RAL-9003)	(1)	096-1281
	E04-EHLK88A0	Horizontal Arm Ass'y (500mm) (RAL-9003)	(1)	096-1282
	E04-EHLK89A0	Horizontal Arm Ass'y (650mm) (RAL-9003)	(1)	096-1283
	E04-EHLK91A0	Horizontal Arm Ass'y (1000mm) (RAL-9003)	(1)	096-1284
29	E04-----	Horizontal Arm	1	096-1290
30	E04-ECLS06A0	Brake Plug	2	096-1300
31	E04-----	Brake Screw (M6-6)	2	096-1310
32	E04-ECLS09A0	Stopper Screw	1	096-1320
33	E04-ECLJ36A0	End Cap (R1-1005)	2	096-1330
34	E04-----	End Cap Screw (M6-15)	2	096-1340
35	E04-ECNR24A0	Hole Plug for End Cap (R1-1005)	2	096-1341
36	E04-EHLL05A0	Arm Mounting Bracket Ass'y (RAL-9003)	(1)	096-1350
37	E04-----	Machine Bolt (M8-20)	3	096-1360
38	E04-ECPR53A0	Bolt Cap (RAL-9003)	3	096-1370
39	E04-ECPR44A0	Retaining Bolt	2	096-1380
40	E04-EHLL15A0	Arm Mounting Bracket Ass'y (RAL-9003)	(1)	096-1390
41	E04-ECPR45B0	Bottom Cover	1	096-1400
42	E04-----	Bottom Cover Screw (M3-6)	2	096-1410
43	E04-ECPR52A0	Bolt Cap (RAL-9003)	4	096-1420
44	E04-----	Coach Bolt (ø9-75) (RAL-9003)	4	096-1430
45	E04-ECPJ19A0	Wall Mount Plate (RAL-9003)	1	096-1620
	E04-ECPJ18A0	Wall Mount Plate for Cover Type	(1)	096-1621
46	E04-EHLL11A0	Wire Harness in Balance Arm	1	096-1081
47	E04-ECNR18A0	Yoke Side Cap (R1-1005)	1	096-1630
48	E04-ECPJ15A0	Yoke Inside Cover (RAL-9003)	1	096-1021
49	E04-ECLJ82A0	Adjust Wrench	1	096-1082
50	E04-EHLL14A0	Cover Set for Wall Mount Plate (RAL-9003) (Option)	(1)	096-1625
60	E04-EHLL07A0	Control Box Assembly (for 120V) (RAL-9003)	(1)	096-1000
61	E04-ECPE01A0	Chassis (R1-1005)	1	096-1440
62	E04-----	Fuse (F1/F2 - 10A)	2	096-1450
63	E04-----	Terminal Block (4P)	1	096-1460
64	E04-----	Power Switch	1	096-1470
65	E04-ECPJ07D0	Covering Plate	1	096-1480
66	E04-----	Timer Board	1	096-1490
67	E04-ECPB01G0	Front Cover	1	096-1500
68	E04-----	Top Screw (M3-8)	2	096-1510
69	E04-----	Fuse (F3 - 0.5A)	1	096-1520
70	E04-----	Wood Screw for Chassis (ø5.8-32)	4	096-1530
71	E04-----	Fuse (F4 - 1A)	1	096-1540
72	E04-----	Terminal Block (5P)	1	096-1550
73	E04-ECNJ47A0	Hook for Hand Exposure Switch	1	096-1560
74	E04-EHLL21A0	Hand Exposure Switch Ass'y	1	096-1570
75	E04-----	Screw for Hook (ø3-12)	1	096-1580
76	E04-ECPR20A0	Restriction Plate	1	096-1590
77	E04-----	Power Board for 120V	1	096-1600
78	E04-ECPJ08D0	Front Sheet (RAL-9003)	1	096-1610

From 2004 July

[3] SLIDING SECTION / ARM AND HEAD ASSEMBLY OF RK TYPE

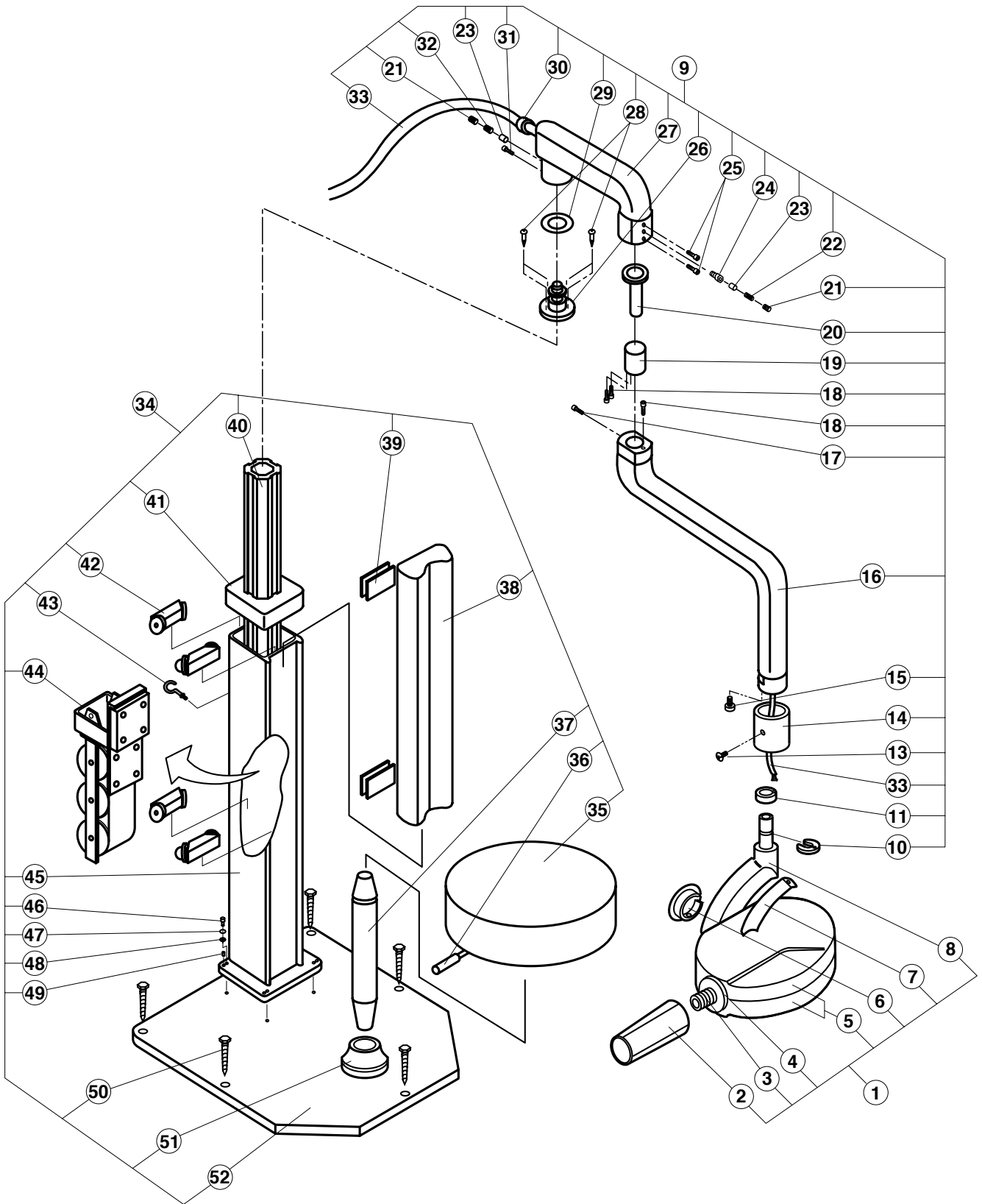

ID.No.	PartsNo.	Description	QTY	USA Code
1	E04-EHLL03A0	X-Ray Head Assembly (RAL-9003)	1	096-1010
2	E04-ECPR21D0	Regular Cone (RAL-9003)	1	096-1060
3	E04-ECPR36A0	X-Ray Exposure Sleeve	1	096-1050
4	E04-ECPR22B0	Lock Ring (R1-1005)	1	096-1040
5	E04-EHLL12A0	Housing Cover Set (RAL-9003)	1	096-1030
6	E04-ECNR18A0	Yoke Side Cap (R1-1005)	1	096-1630
7	E04-ECPJ15A0	Yoke Inside Cover (RAL-9003)	1	096-1021
8	E04-ECPE03G0	Yoke (RAL-9003)	1	096-1020
9	E04-EHLL20A0	Swing Arm Assembly (RAL-9003)	1	
10	E04-ECLR95B0	Head Key	1	096-1270
11	E04-ECLS01A0	Stopper Ring	1	096-1090
13	E04-----	Collar Screw (SUS M4-8)	1	096-1110
14	E04-ECLS22A0	Collar (R1-1005)	1	096-1120
15	E04-----	Stopper Screw(M4-8)	1	096-1130
16	E04-ECLF20B0	Swing Arm 1(RAL-9003)	1	
17	E04-----	Swing Arm Pin Screw(M6-16)	1	
18	E04-----	Stopper Screw(M4-8)	3	
19	E04-ECLT47B0	Swing Arm Sleeve	1	
20	E04-ECLT46C0	Swing Arm Pin	1	
21	E04-----	Brake Screw(M6-6)	2	
22	E04-ECLS11B0	Brake Spring(ø5-11)	1	
23	E04-ECLS06A0	Brake Plug	2	
24	E04-ECLS12A0	Brake Sleeve	1	
25	E04-----	Swing Arm Sleeve Screw(M5-8)	2	
26	E04-ECLT44A0	Swing Arm Joint	1	
27	E04-ECLF19B0	Swing Arm 2 W/Belmont Seal(RAI-9003)	1	
28	E04-----	Tapping Screw(ø4.5-40)	4	
29	E04-ECLT45A0	Thrust Washer(ø42-12)	1	
30	E04-EEMU19A0	Bushing	1	
31	E04-ECLS09A0	Stopper Bolt(M6-15)	1	
32	E04-ECLS47A0	Brake Spring(ø4.7-7)	1	
33	E04-EHLZ38A0	Cable W/Connector	1	
34	E04-EHLL19A0	Column Assembly (RAL-9003)	1	
35	E04-ECLK76A0	Seat Cushion (NL-3)	1	
36	E04-F32270	Knob(black)	1	
37	E04-P30080	Gas Cylinder	1	
38	E04-ECLK73A0	Backrest Cushion (NL-3)	1	
39	E04-ECLT50A0	Cushion Plate	4	
40	E04-ECLK69A0	Sliding Post	1	
41	E04-EALJ14A0	Column Cover	1	
42	E04-EHLZ37A0	Guide Roller Assembly	4	
43	E04-EFPR02A0	Cable Guide W/Nut	1	
44	E04-EHLL17A0	Constant Tension Spring Assembly	1	
45	E04-EHLL18A0	Column W/Sub Plate(RAL-9003)	1	
46	E04-----	Mounting Bolt(M6-20)	4	
47	E04-----	Spring Washer(M6)	4	
48	E04-----	Washer(M6)	4	
49	E04-----	Set Screw(M8-12)	4	
50	E04-----	Lag Bolt(ø8-45)	5	
51	E04-ECLT53A0	Gas Cylinder Sleeve(R1-1005)	1	
52	E04-ECLK75B0	Base Plate(R1-1005)	1	

APPENDIX THREE : CERTIFICATION

FORM FDA 2579 FROM THE DEPARTMENT OF HEALTH AND HUMAN SERVICES MUST BE FILLED AND MAILED TO THE RESPECTIVE AGENCIES FOR THIS INSTALLATION TO BE CONSIDERED COMPLETE. ALSO COMPLETE THE WARRANTY CARD AND THE ASSEMBLER'S INSTALLATION REPORT AND RETURN TO BELMONT EQUIPMENT CORP.

REFER TO THE SAMPLE FORM:

FOR FDA USE ONLY	DEPARTMENT OF HEALTH AND HUMAN SERVICES PUBLIC HEALTH SERVICE FOOD AND DRUG ADMINISTRATION REPORT OF ASSEMBLY OF A DIAGNOSTIC X-RAY SYSTEM	From Approved: OMB No. 0910-0213 Expiration Date: December 31, 1992 See reverse for OMB statement. D XXXXXX																																																																					
<table border="1" style="width:100%; border-collapse: collapse;"> <tr> <td colspan="2" style="text-align:center;">1. EQUIPMENT LOCATION</td> <td colspan="2" style="text-align:center;">2. ASSEMBLER INFORMATION</td> </tr> <tr> <td colspan="2">a. NAME OF HOSPITAL, DOCTOR OR OFFICE WHERE INSTALLED ✓</td> <td colspan="2">a. COMPANY NAME ✓</td> </tr> <tr> <td colspan="2">b. STREET ADDRESS ✓</td> <td colspan="2">b. STREET ADDRESS ✓</td> </tr> <tr> <td>c. CITY ✓</td> <td>d. STATE ✓</td> <td>c. CITY ✓</td> <td>d. STATE ✓</td> </tr> <tr> <td>e. ZIP CODE ✓</td> <td>f. TELEPHONE NUMBER ✓</td> <td>e. ZIP CODE ✓</td> <td>f. TELEPHONE NUMBER ✓</td> </tr> </table>			1. EQUIPMENT LOCATION		2. ASSEMBLER INFORMATION		a. NAME OF HOSPITAL, DOCTOR OR OFFICE WHERE INSTALLED ✓		a. COMPANY NAME ✓		b. STREET ADDRESS ✓		b. STREET ADDRESS ✓		c. CITY ✓	d. STATE ✓	c. CITY ✓	d. STATE ✓	e. ZIP CODE ✓	f. TELEPHONE NUMBER ✓	e. ZIP CODE ✓	f. TELEPHONE NUMBER ✓																																																	
1. EQUIPMENT LOCATION		2. ASSEMBLER INFORMATION																																																																					
a. NAME OF HOSPITAL, DOCTOR OR OFFICE WHERE INSTALLED ✓		a. COMPANY NAME ✓																																																																					
b. STREET ADDRESS ✓		b. STREET ADDRESS ✓																																																																					
c. CITY ✓	d. STATE ✓	c. CITY ✓	d. STATE ✓																																																																				
e. ZIP CODE ✓	f. TELEPHONE NUMBER ✓	e. ZIP CODE ✓	f. TELEPHONE NUMBER ✓																																																																				
<table border="1" style="width:100%; border-collapse: collapse;"> <tr> <td colspan="4" style="text-align:center;">3. GENERAL INFORMATION</td> </tr> <tr> <td colspan="4">a. THIS REPORT IS FOR ASSEMBLY OF CERTIFIED COMPONENTS WHICH ARE (Check appropriate box(es))</td> </tr> <tr> <td colspan="2"><input checked="" type="checkbox"/> NEW ASSEMBLY - FULLY CERTIFIED SYSTEM</td> <td colspan="2"><input type="checkbox"/> REPLACEMENT COMPONENTS IN AN EXISTING SYSTEM</td> </tr> <tr> <td colspan="2"><input type="checkbox"/> REASSEMBLY - FULLY CERTIFIED SYSTEM</td> <td colspan="2"><input type="checkbox"/> AN ADDITION TO AN EXISTING SYSTEM</td> </tr> <tr> <td colspan="2"><input type="checkbox"/> REASSEMBLY - MIXED SYSTEM (Both certified and uncertified components)</td> <td colspan="2"></td> </tr> <tr> <td colspan="4">b. INTENDED USE(S) (Check applicable box(es))</td> </tr> <tr> <td><input type="checkbox"/> GENERAL PURPOSE RADIOGRAPHY</td> <td><input type="checkbox"/> PODIATRY</td> <td><input type="checkbox"/> CT HEAD SCANNER</td> <td><input type="checkbox"/> DENTAL PANORAMIC</td> </tr> <tr> <td><input type="checkbox"/> GENERAL PURPOSE FLUOROSCOPY</td> <td><input type="checkbox"/> UROLOGY</td> <td><input type="checkbox"/> CT WHOLE BODY SCANNER</td> <td><input type="checkbox"/> RADIATION THERAPY SIMULATOR</td> </tr> <tr> <td><input type="checkbox"/> TOMOGRAPHY (Other than CT)</td> <td><input type="checkbox"/> MAMMOGRAPHY</td> <td><input type="checkbox"/> HEAD - NECK (Medical)</td> <td><input type="checkbox"/> C - ARM FLUOROSCOPIC</td> </tr> <tr> <td><input type="checkbox"/> ANGIOGRAPHY</td> <td><input type="checkbox"/> CHEST</td> <td><input checked="" type="checkbox"/> DENTAL - INTRAORAL</td> <td><input type="checkbox"/> DIGITAL</td> </tr> <tr> <td></td> <td><input type="checkbox"/> CHIROPRACTIC</td> <td><input type="checkbox"/> DENTAL - CEPHALOMETRIC</td> <td><input type="checkbox"/> OTHER (Specify in comments)</td> </tr> <tr> <td colspan="2">c. THE X-RAY SYSTEM IS (Check one)</td> <td colspan="2">d. THE MASTER CONTROL IS IN ROOM</td> </tr> <tr> <td colspan="2"><input checked="" type="checkbox"/> STATIONARY</td> <td colspan="2" style="text-align:center;">Location of Control Box</td> </tr> <tr> <td colspan="2"><input type="checkbox"/> MOBILE</td> <td colspan="2">e. DATE OF ASSEMBLY</td> </tr> <tr> <td colspan="2"></td> <td colspan="2" style="text-align:center;"> <table style="margin:auto;"> <tr> <td style="text-align:center;">✓</td> <td style="text-align:center;">✓</td> <td style="text-align:center;">✓</td> </tr> <tr> <td style="text-align:center;">(mo.)</td> <td style="text-align:center;">(day)</td> <td style="text-align:center;">(yr.)</td> </tr> </table> </td> </tr> </table>				3. GENERAL INFORMATION				a. THIS REPORT IS FOR ASSEMBLY OF CERTIFIED COMPONENTS WHICH ARE (Check appropriate box(es))				<input checked="" type="checkbox"/> NEW ASSEMBLY - FULLY CERTIFIED SYSTEM		<input type="checkbox"/> REPLACEMENT COMPONENTS IN AN EXISTING SYSTEM		<input type="checkbox"/> REASSEMBLY - FULLY CERTIFIED SYSTEM		<input type="checkbox"/> AN ADDITION TO AN EXISTING SYSTEM		<input type="checkbox"/> REASSEMBLY - MIXED SYSTEM (Both certified and uncertified components)				b. INTENDED USE(S) (Check applicable box(es))				<input type="checkbox"/> GENERAL PURPOSE RADIOGRAPHY	<input type="checkbox"/> PODIATRY	<input type="checkbox"/> CT HEAD SCANNER	<input type="checkbox"/> DENTAL PANORAMIC	<input type="checkbox"/> GENERAL PURPOSE FLUOROSCOPY	<input type="checkbox"/> UROLOGY	<input type="checkbox"/> CT WHOLE BODY SCANNER	<input type="checkbox"/> RADIATION THERAPY SIMULATOR	<input type="checkbox"/> TOMOGRAPHY (Other than CT)	<input type="checkbox"/> MAMMOGRAPHY	<input type="checkbox"/> HEAD - NECK (Medical)	<input type="checkbox"/> C - ARM FLUOROSCOPIC	<input type="checkbox"/> ANGIOGRAPHY	<input type="checkbox"/> CHEST	<input checked="" type="checkbox"/> DENTAL - INTRAORAL	<input type="checkbox"/> DIGITAL		<input type="checkbox"/> CHIROPRACTIC	<input type="checkbox"/> DENTAL - CEPHALOMETRIC	<input type="checkbox"/> OTHER (Specify in comments)	c. THE X-RAY SYSTEM IS (Check one)		d. THE MASTER CONTROL IS IN ROOM		<input checked="" type="checkbox"/> STATIONARY		Location of Control Box		<input type="checkbox"/> MOBILE		e. DATE OF ASSEMBLY				<table style="margin:auto;"> <tr> <td style="text-align:center;">✓</td> <td style="text-align:center;">✓</td> <td style="text-align:center;">✓</td> </tr> <tr> <td style="text-align:center;">(mo.)</td> <td style="text-align:center;">(day)</td> <td style="text-align:center;">(yr.)</td> </tr> </table>		✓	✓	✓	(mo.)	(day)	(yr.)		
3. GENERAL INFORMATION																																																																							
a. THIS REPORT IS FOR ASSEMBLY OF CERTIFIED COMPONENTS WHICH ARE (Check appropriate box(es))																																																																							
<input checked="" type="checkbox"/> NEW ASSEMBLY - FULLY CERTIFIED SYSTEM		<input type="checkbox"/> REPLACEMENT COMPONENTS IN AN EXISTING SYSTEM																																																																					
<input type="checkbox"/> REASSEMBLY - FULLY CERTIFIED SYSTEM		<input type="checkbox"/> AN ADDITION TO AN EXISTING SYSTEM																																																																					
<input type="checkbox"/> REASSEMBLY - MIXED SYSTEM (Both certified and uncertified components)																																																																							
b. INTENDED USE(S) (Check applicable box(es))																																																																							
<input type="checkbox"/> GENERAL PURPOSE RADIOGRAPHY	<input type="checkbox"/> PODIATRY	<input type="checkbox"/> CT HEAD SCANNER	<input type="checkbox"/> DENTAL PANORAMIC																																																																				
<input type="checkbox"/> GENERAL PURPOSE FLUOROSCOPY	<input type="checkbox"/> UROLOGY	<input type="checkbox"/> CT WHOLE BODY SCANNER	<input type="checkbox"/> RADIATION THERAPY SIMULATOR																																																																				
<input type="checkbox"/> TOMOGRAPHY (Other than CT)	<input type="checkbox"/> MAMMOGRAPHY	<input type="checkbox"/> HEAD - NECK (Medical)	<input type="checkbox"/> C - ARM FLUOROSCOPIC																																																																				
<input type="checkbox"/> ANGIOGRAPHY	<input type="checkbox"/> CHEST	<input checked="" type="checkbox"/> DENTAL - INTRAORAL	<input type="checkbox"/> DIGITAL																																																																				
	<input type="checkbox"/> CHIROPRACTIC	<input type="checkbox"/> DENTAL - CEPHALOMETRIC	<input type="checkbox"/> OTHER (Specify in comments)																																																																				
c. THE X-RAY SYSTEM IS (Check one)		d. THE MASTER CONTROL IS IN ROOM																																																																					
<input checked="" type="checkbox"/> STATIONARY		Location of Control Box																																																																					
<input type="checkbox"/> MOBILE		e. DATE OF ASSEMBLY																																																																					
		<table style="margin:auto;"> <tr> <td style="text-align:center;">✓</td> <td style="text-align:center;">✓</td> <td style="text-align:center;">✓</td> </tr> <tr> <td style="text-align:center;">(mo.)</td> <td style="text-align:center;">(day)</td> <td style="text-align:center;">(yr.)</td> </tr> </table>		✓	✓	✓	(mo.)	(day)	(yr.)																																																														
✓	✓	✓																																																																					
(mo.)	(day)	(yr.)																																																																					
<table border="1" style="width:100%; border-collapse: collapse;"> <tr> <td colspan="4" style="text-align:center;">4. COMPONENT INFORMATION (If additional space is needed for this section use another form, replacing the preprinted number with form Number and complete items 1, 4, and 5 only)</td> </tr> <tr> <td colspan="2">a. THE MASTER CONTROL IS</td> <td colspan="1">b. CONTROL MANUFACTURER</td> <td colspan="1">b. CONTROL SERIAL NUMBER</td> </tr> <tr> <td colspan="2"><input checked="" type="checkbox"/> A NEW INSTALLATION</td> <td colspan="1" style="text-align:center;">Takara Belmont, USA Inc.</td> <td colspan="1" style="text-align:center;">✓</td> </tr> <tr> <td colspan="2"><input type="checkbox"/> EXISTING (Certified)</td> <td colspan="1">c. CONTROL MODEL NUMBER</td> <td colspan="1">c. SYSTEM MODEL NAME (CT Systems Only)</td> </tr> <tr> <td colspan="2"><input type="checkbox"/> EXISTING (Non-certified)</td> <td colspan="1" style="text-align:center;">096-C</td> <td colspan="1"></td> </tr> <tr> <td colspan="4">Complete the following information for the certified components listed below which you installed. For beam limited device, tables and CT gantries the manufacturer and Model number in the indicated spaces. For other certified components, enter in the appropriate block how many of each you installed in this system.</td> </tr> <tr> <td colspan="4" style="text-align:center;">f. SELECTED COMPONENTS</td> </tr> <tr> <td style="text-align:center;">BEAM LIMITED DEVICE</td> <td>MANUFACTURER</td> <td>MODEL NUMBER</td> <td>DATE MANUFACTURED</td> </tr> <tr> <td style="text-align:center;">TABLES</td> <td>MANUFACTURER</td> <td>MODEL NUMBER</td> <td>DATE MANUFACTURED</td> </tr> <tr> <td style="text-align:center;">CT GANTRY</td> <td>MANUFACTURER</td> <td>MODEL NUMBER</td> <td>DATE MANUFACTURED</td> </tr> <tr> <td colspan="4" style="text-align:center;">g. OTHER CERTIFIED COMPONENTS</td> </tr> <tr> <td colspan="4" style="text-align:center;">(Enter number of each installed in appropriate blocks)</td> </tr> <tr> <td style="text-align:center;">1</td> <td>X-RAY CONTROL</td> <td><input type="checkbox"/></td> <td>CRADLE</td> </tr> <tr> <td><input type="checkbox"/></td> <td>HIGH VOLTAGE GENERATOR</td> <td><input type="checkbox"/></td> <td>FILM CHANGER</td> </tr> <tr> <td><input type="checkbox"/></td> <td>VERTICAL CASSETTE HOLDER</td> <td><input type="checkbox"/></td> <td>IMAGE INTENSIFIER</td> </tr> <tr> <td><input type="checkbox"/></td> <td>TUBE HOUSING ASSEMBLY (Medical)</td> <td><input type="checkbox"/></td> <td>SPOT FILM DEVICE</td> </tr> <tr> <td style="text-align:center;">1</td> <td>DENTAL TUBE HEAD</td> <td><input type="checkbox"/></td> <td>OTHER (Specify)</td> </tr> </table>				4. COMPONENT INFORMATION (If additional space is needed for this section use another form, replacing the preprinted number with form Number and complete items 1, 4, and 5 only)				a. THE MASTER CONTROL IS		b. CONTROL MANUFACTURER	b. CONTROL SERIAL NUMBER	<input checked="" type="checkbox"/> A NEW INSTALLATION		Takara Belmont, USA Inc.	✓	<input type="checkbox"/> EXISTING (Certified)		c. CONTROL MODEL NUMBER	c. SYSTEM MODEL NAME (CT Systems Only)	<input type="checkbox"/> EXISTING (Non-certified)		096-C		Complete the following information for the certified components listed below which you installed. For beam limited device, tables and CT gantries the manufacturer and Model number in the indicated spaces. For other certified components, enter in the appropriate block how many of each you installed in this system.				f. SELECTED COMPONENTS				BEAM LIMITED DEVICE	MANUFACTURER	MODEL NUMBER	DATE MANUFACTURED	TABLES	MANUFACTURER	MODEL NUMBER	DATE MANUFACTURED	CT GANTRY	MANUFACTURER	MODEL NUMBER	DATE MANUFACTURED	g. OTHER CERTIFIED COMPONENTS				(Enter number of each installed in appropriate blocks)				1	X-RAY CONTROL	<input type="checkbox"/>	CRADLE	<input type="checkbox"/>	HIGH VOLTAGE GENERATOR	<input type="checkbox"/>	FILM CHANGER	<input type="checkbox"/>	VERTICAL CASSETTE HOLDER	<input type="checkbox"/>	IMAGE INTENSIFIER	<input type="checkbox"/>	TUBE HOUSING ASSEMBLY (Medical)	<input type="checkbox"/>	SPOT FILM DEVICE	1	DENTAL TUBE HEAD	<input type="checkbox"/>	OTHER (Specify)
4. COMPONENT INFORMATION (If additional space is needed for this section use another form, replacing the preprinted number with form Number and complete items 1, 4, and 5 only)																																																																							
a. THE MASTER CONTROL IS		b. CONTROL MANUFACTURER	b. CONTROL SERIAL NUMBER																																																																				
<input checked="" type="checkbox"/> A NEW INSTALLATION		Takara Belmont, USA Inc.	✓																																																																				
<input type="checkbox"/> EXISTING (Certified)		c. CONTROL MODEL NUMBER	c. SYSTEM MODEL NAME (CT Systems Only)																																																																				
<input type="checkbox"/> EXISTING (Non-certified)		096-C																																																																					
Complete the following information for the certified components listed below which you installed. For beam limited device, tables and CT gantries the manufacturer and Model number in the indicated spaces. For other certified components, enter in the appropriate block how many of each you installed in this system.																																																																							
f. SELECTED COMPONENTS																																																																							
BEAM LIMITED DEVICE	MANUFACTURER	MODEL NUMBER	DATE MANUFACTURED																																																																				
TABLES	MANUFACTURER	MODEL NUMBER	DATE MANUFACTURED																																																																				
CT GANTRY	MANUFACTURER	MODEL NUMBER	DATE MANUFACTURED																																																																				
g. OTHER CERTIFIED COMPONENTS																																																																							
(Enter number of each installed in appropriate blocks)																																																																							
1	X-RAY CONTROL	<input type="checkbox"/>	CRADLE																																																																				
<input type="checkbox"/>	HIGH VOLTAGE GENERATOR	<input type="checkbox"/>	FILM CHANGER																																																																				
<input type="checkbox"/>	VERTICAL CASSETTE HOLDER	<input type="checkbox"/>	IMAGE INTENSIFIER																																																																				
<input type="checkbox"/>	TUBE HOUSING ASSEMBLY (Medical)	<input type="checkbox"/>	SPOT FILM DEVICE																																																																				
1	DENTAL TUBE HEAD	<input type="checkbox"/>	OTHER (Specify)																																																																				
<table border="1" style="width:100%; border-collapse: collapse;"> <tr> <td colspan="3" style="text-align:center;">5. ASSEMBLER CERTIFICATION</td> </tr> <tr> <td colspan="3">I affirm that all certified components assembled or installed by me for which this report is being made, were adjusted and tested by me according to the instructions provided by the manufacturer(s), were of the type required by the diagnostic x-ray performance standard (21 CFR Part 1020), were not modified to adversely affect performance, and were installed in accordance with provisions of 21 CFR Part 1020. I also affirm that all instruction manuals and other information required by 21 CFR Part 1020 for this assembly have been furnished to the purchaser and within 15 days from the date of assembly, each copy of this report will be distributed as indicated at the bottom of each copy.</td> </tr> <tr> <td>a. PRINTED NAME ✓</td> <td>b. SIGNATURE ✓</td> <td>c. DATE ✓</td> </tr> <tr> <td colspan="3">d. COMMENTS</td> </tr> </table>				5. ASSEMBLER CERTIFICATION			I affirm that all certified components assembled or installed by me for which this report is being made, were adjusted and tested by me according to the instructions provided by the manufacturer(s), were of the type required by the diagnostic x-ray performance standard (21 CFR Part 1020), were not modified to adversely affect performance, and were installed in accordance with provisions of 21 CFR Part 1020. I also affirm that all instruction manuals and other information required by 21 CFR Part 1020 for this assembly have been furnished to the purchaser and within 15 days from the date of assembly, each copy of this report will be distributed as indicated at the bottom of each copy.			a. PRINTED NAME ✓	b. SIGNATURE ✓	c. DATE ✓	d. COMMENTS																																																										
5. ASSEMBLER CERTIFICATION																																																																							
I affirm that all certified components assembled or installed by me for which this report is being made, were adjusted and tested by me according to the instructions provided by the manufacturer(s), were of the type required by the diagnostic x-ray performance standard (21 CFR Part 1020), were not modified to adversely affect performance, and were installed in accordance with provisions of 21 CFR Part 1020. I also affirm that all instruction manuals and other information required by 21 CFR Part 1020 for this assembly have been furnished to the purchaser and within 15 days from the date of assembly, each copy of this report will be distributed as indicated at the bottom of each copy.																																																																							
a. PRINTED NAME ✓	b. SIGNATURE ✓	c. DATE ✓																																																																					
d. COMMENTS																																																																							

FORM FDA 2579(7/92) PREVIOUS EDITION IS OBSOLETE



BELMONT EQUIPMENT, Division of Takara Belmont, USA, Inc.

101 Belmont Drive Somerset, New Jersey 08873 U.S.A. TEL.:(732) 469-5000 / (800) 223-1192 Fax.:(732)526-6322 / (800) 280-7504

TAKARA CO, CANADA LTD.

2076 S. Sheridan Way, Mississauga, Ont., L5J2M4, Can. TEL.:(905) 822-2755 Fax.:(905)822-6203

Book No. EDAP7
Printed in Japan 0504 MA