

BELRAY

MODEL 096

DENTAL X-RAY

**SERVICE
MANUAL**

(for USA & Canada)

 **Belmont**

INDEX

	PAGE
SECTION 1 : TECHNICAL DATA	
[1] ELECTRICAL AND RADIATION DATA	3
[2] PHYSICAL DIMENSIONS	4
[3] TUBE HEAD THERMAL CHARACTERISTICS	5
SECTION 2 : OPERATION INSTRUCTIONS	
[1] LAYOUT OF CONTROL BOX	6
[2] FUNCTION OF CONTROLS	7
[3] OPERATING PROCEDURES FOR NORMAL USE	9
[4] ALTERATION OF SETTING	10
SECTION 3 : DESCRIPTION FOR FUNCTIONS	
[1] GENERAL	14
[2] AUTOMATIC VOLTAGE REGULATOR	14
[3] PRIMARY CIRCUIT OF HIGH VOLTAGE TRANSFORMER	16
[4] PRIMARY CIRCUIT OF FILAMENT TRANSFORMER	16
[5] AUTOMATIC TUBE CURRENT CONTROL	17
SECTION 4 : ADJUSTMENT	
[1] AVR VOLTAGE	18
[2] INSPECTION OF TUBE CURRENT	19
[3] ADJUSTMENT OF TUBE CURRENT	21
[4] ADJUSTMENT OF LINE VOLTAGE MEASUREMENT ERROR	22
SECTION 5 : PERIODIC INSPECTION AND ADJUSTMENT	
[1] ELECTRICAL INSPECTION AND ADJUSTMENT	23
[2] MECHANICAL INSPECTION	24
SECTION 6 : COMPONENT VERIFICATION	
[1] CONTROL BOX	25
[2] TUBE HEAD	26
[3] WIRING BETWEEN HEAD AND CONTROL BOX	27
SECTION 7 : ERROR CODE	28
SECTION 8 : TROUBLE SHOOTING	31
SECTION 9 : REPLACEMENT OF COMPONENT	
[1] CONTROL BOX	32
[2] TUBE HEAD	32
SECTION 10 : CIRCUIT DIAGRAM	33
SECTION 11 : PARTS IDENTIFICATION	
[1] ARM AND HEAD ASSEMBLY	34
[2] CONTROL BOX ASSEMBLY	34

SECTION 1 : TECHNICAL DATA

[1] ELECTRICAL AND RADIATION DATA

1. Focal point measurement	0.8 mm x 0.8 mm
2. Rated peak tube potential	70 kVp
3. Rated tube current	10 mA
4. Maximum rated peak tube potential	70 kVp
5. Rated line voltage	120 V AC
6. Line voltage range	108 V AC ~ 132 V AC
7. Range of line voltage regulation	2 ~ 5 %
8. Rated line current	10.8 A at 70 kVp, 10 mA
9. Maximum line current	11.9 A at 70 kVp, 10 mA
10. Exposure time	0.02 ~ 3 sec. (ON and OFF are zero crossed.)
11. Timer accuracy	± 1 pulse (1/60 sec.)
12. Inherent filtration	1.3 mmAl Equivalent
13. Added filtration	0.8 mmAl
14. Minimum filtration permanently in useful beam	2.1 mmAl Equivalent at 70 kVp
15. Nominal roentgen output	
a. Distal end of regular cone	1.30 R/sec. + 30 %, - 40 %
b. Distal end of long cone	0.58 R/sec. + 30 %, - 40 %
	(Data obtained by direct measurement in the useful beam)
16. Source to skin distance	
a. Regular cone	204 mm
b. Long cone	305 mm
17. Leakage technique factor	70 kVp / 0.16 mA
	0.16 mA is maximum rated continuous current for 10 mA with a duty cycle 1: 60
18. Duty cycle	1: 60 (0.5 sec. exposure with 30 sec. interval)
19. Maximum deviation of tube potential and tube current	Pulse Tube Potential Tube Current
	1st,2nd & 3rd 70 ⁺⁸ _{.11} kVp 10 ± 2 mA
	4th & Up 70 ⁺⁷ _{.10} kVp 10 ± 1 mA
20. Measurement base of technique factors	
a. peak tube potential	Peak tube potential of conducting half cycle
b. tube current	Average of tube current during one cycle of line frequency
c. exposure time	Impulses of power line frequency
21. Half value layer	1.5 mmAl over
22. Source to the base of cone distance	81 mm

[2] **PHYSICAL DIMENSIONS**

() = mm

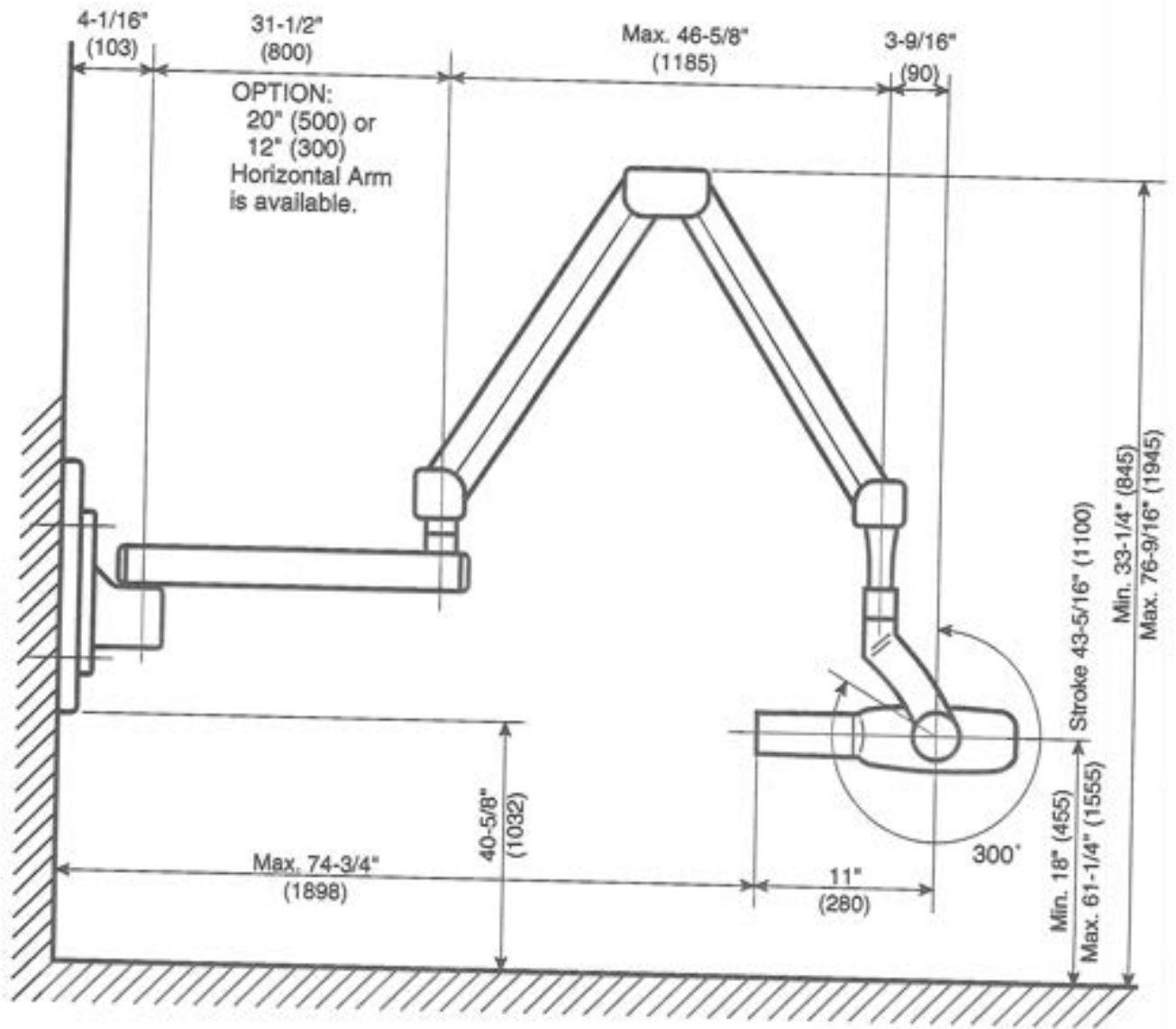
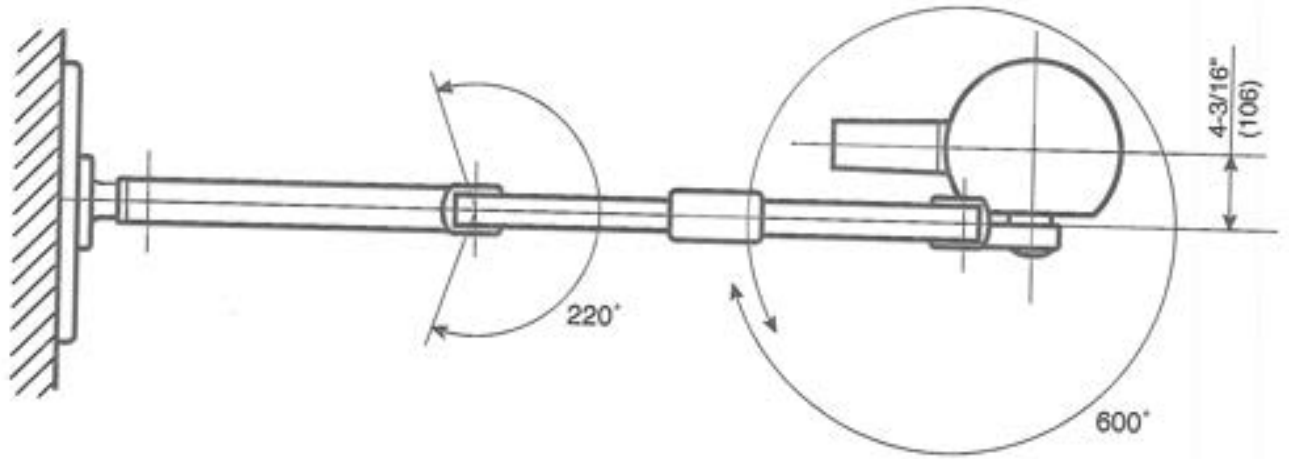

[3] TUBE HEAD THERMAL CHARACTERISTICS

A. Interval between each exposure

The temperature inside of the tube head rises, when an exposure is made. The value of the heat generated is measured in Heat Unit (HU), which is the product of tube potential, tube current and exposure time. Excessive heat will be accumulated inside of the tube head, if the x-ray is used without a proper cool down interval between each exposure. The excessive heat may damage the x-ray tube, high voltage generator or both.

B. Duty cycle

To avoid the accumulation of excess heat in an effort to prolong the tube head life, a cool down interval of 60 seconds or more must be allowed between each 1 second exposure. or a 30 second cool down must be allowed between each 0.5 second (30 impulses) exposure.

C. Tube head cooling curve

1. Tube Housing cooling curve

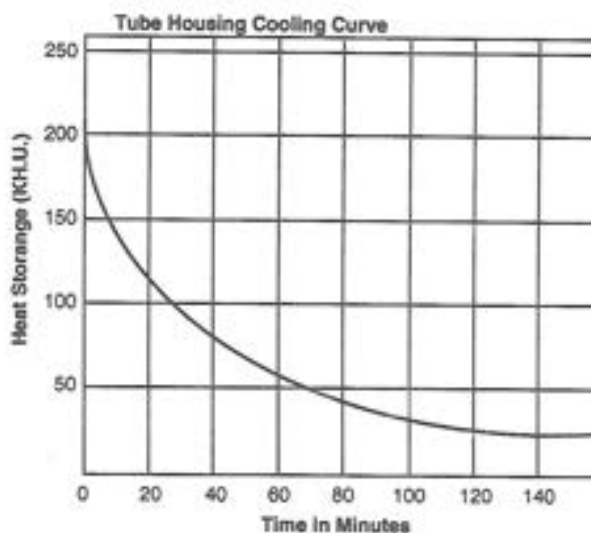

2. Anode thermal characteristics

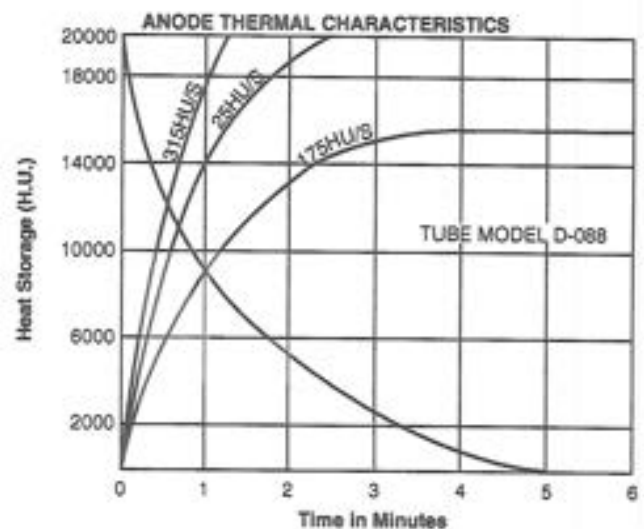

3. Maximum rating chart

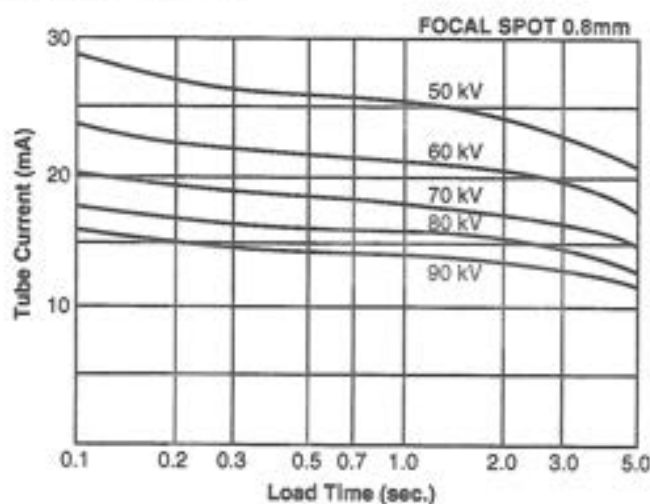

SECTION 2 : OPERATION INSTRUCTION

[1] LAYOUT OF CONTROLBOX

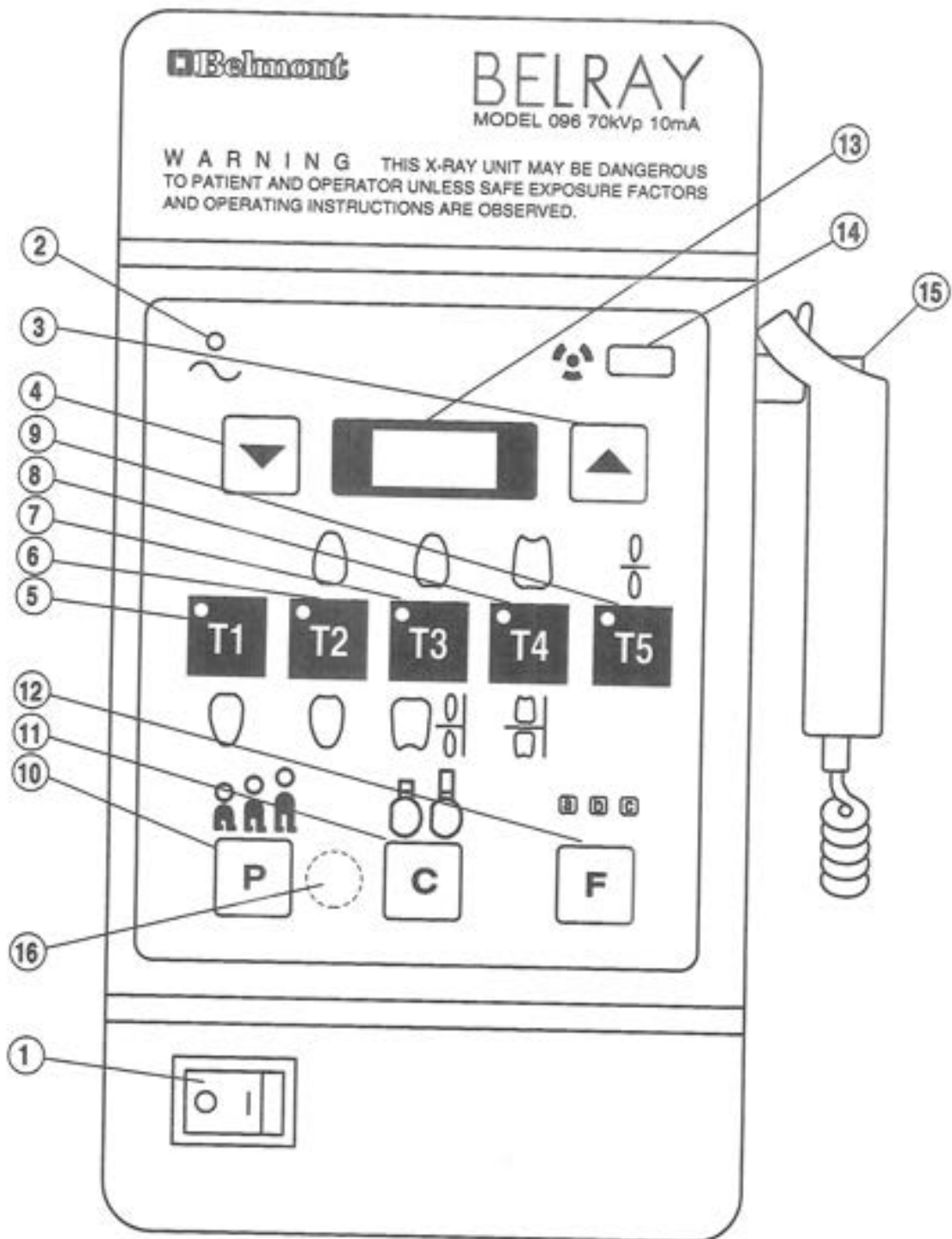

- ① Main Power switch
- ② Ready Lamp
- ③ Exposure Time Adjusting Sw.(Up)
- ④ Exposure Time Adjusting Sw.(Down)
- ⑤ Tooth Selection Switch (T1)
- ⑥ Tooth Selection Switch (T2)
- ⑦ Tooth Selection Switch (T3)
- ⑧ Tooth Selection Switch (T4)
- ⑨ Tooth Selection Switch (T5)

- ⑩ Patient Size Selection Switch
- ⑪ Cone Type Selection Switch
- ⑫ Film Speed Selection Switch
- ⑬ Exposure Time Display Window
- ⑭ Exposure Warning Light
- ⑮ Exposure Switch
- ⑯ Technical Switch

[2] FUNCTION OF CONTROLS

① Main Power switch

Pushing right side of this switch energizes the x-ray unit.

(Ready lamp and pre-selected lamps for patient size, cone type and film speed illuminates.)

It is recommended to keep this switch OFF when the unit is not in use in order to prevent an accidental exposure.

② Ready Lamp

This lamp lights when the line voltage is within operable range.

When this lamp is not on, exposure can not be made.

③,④ Exposure Time Adjusting Switches

By momentarily pushing ▲(or ▼) switch, exposure time displayed increases (or decreases) by one step. By keeping the switch depressed more than 2 sec., exposure time displayed increases (or decreases) continuously until the switch is released.

⑤-⑨ Tooth Selection Switch (T1 ~ T5)

Pushing one of these switches set the exposure time automatically in combination with following ⑩-⑫.

⑤ T1 : Incisor of Mandible

⑥ T2 : Incisor of Maxilla, Cuspid & Premolar of Mandible

⑦ T3 : Cuspid & Premolar of Maxilla, Molars of Mandible, Bitewing

⑧ T4 : Molars of Maxilla, Bitewing Molars

⑨ T5 : Occlusal

⑩ Patient Size Selection Switch

Pushing this switch alters the selection of patient size (small → medium → large → small) and sets the exposure time accordingly.

⑪ Cone Type Selection Switch

The exposure time corresponding to the cone type being used (Standard Regular Cone or Optional Long Cone) can be selected by this switch.

⑫ Film Speed Selection Switch

Three types of film speed can be registered. Pushing this switch momentarily indicates the film speed number being selected in exposure time display window(⑬). Depressing the switch for more than 2 seconds alters the film type being selected.

NOTE : Setting or adjusting the exposure time manually (with ▲ or ▼ switch) supersedes ⑤-⑫ functions.

⑬ Exposure Time Display Window

Normally the exposure time selected is displayed.

1. E.00 ~ E.09 :Error code [See page 19 of this manual]
2. F.00 ~ F.15 :Film type [See page 21 & 22 of this manual]
3. Tube Current :The tube current of the last pulse of the exposure can be displayed if the exposure switch is kept depressed after exposure is over and technical switch⑯ is depressed.
4. bu.0, bu.1 :Buzzer ON/OFF when a switch is activated. [See page 23 of this manual]
5. Fln :Confirmation of tube current [See page 20 of this manual]
6. PH.0 ~ PH.F :To adjust tube current at beginning of exposure [Refer to service manual]
7. EP.0 ~ EP.F :To adjust tube current when stabilized [Refer to service manual]

⑭ Exposure Warning Light

Illumination of this light indicates the unit is producing x-radiation.

⑮ Exposure Switch

Deadman Type exposure switch. When making an exposure, depress this switch and keep it depressed until the exposure warning light⑭ and the audible warning terminate. Failure to keep this switch depressed will result in premature termination of the exposure.

⑯ Technical Switch

This switch is exclusively for the installer and service personnel. It is used for following purposes:

1. The tube current (mA) of the last pulse of the exposure can be displayed in exposure time display window⑬ if the exposure switch is kept depressed even after the exposure is over and this technical switch is depressed. Display will return to exposure time when the exposure switch is released.
2. Priority of selection (Patient Size, Cone Type, Film Speed) can be changed when the main power switch is turned on while this switch is depressed. [See section Seven of this manual]
3. Memorizing : After setting film speed, priority of selection and/or buzzer ON/OFF, this switch is used for memorize these settings. [See section Seven of this manual.]

[3] OPERATING PROCEDURES

1. Turn ON the main power switch①.
2. Confirm that ready lamp② is illuminated.
NOTE: The ready lamp will not illuminate unless the incoming line voltage is correct and within the x-ray's operable range.
3. Select the appropriate tooth type(⑤~⑨), and confirm if the pre-selected conditions (patient size⑩, cone type⑪ and film speed⑫) are suitable for radiographing.

NOTE: To manually set the exposure time, depress either manual exposure time adjust switch(③▲ or ④▼) until the desired exposure time is displayed in exposure time display window⑬. While the unit is in manual mode, other selection switches(⑤~⑫) do not affect exposure time. (All the tooth selection lamps are off.)

To return to the automatic exposure time selection mode, depress any one of tooth selection switches.

4. Depress the exposure switch⑮. When the exposure switch is depressed, the exposure warning lamp⑭ illuminates and the audible warning sounds. Do not release the exposure switch until the audible warning and the warning lamp terminate. Failure to keep the switch depressed will result in the exposure being terminated prematurely.
5. To continue to radiograph other teeth, just select appropriate tooth selection switch.

IMPORTANT : To protect x-ray tubehead from heat accumulation, wait for 60 times of exposure time between exposures.

[Ex. 30 second wait interval for each 0.5 sec.(30 impulses) exposure]

6. After use turn OFF the main power switch① in order to prevent accidental exposures.

NOTE : If the unit is left over 8 minutes without being operated and the main power switch is kept on, figure 1 runs through the exposure time display window. This does not mean that a malfunction of the unit has occurred, but saves energy. The unit returns to normal condition by pressing any one of the switches except the exposure switch.

[4] ALTERATION OF SETTING

(1) FILM SPEED

As factory installation, following three kinds of film speed are registered to be selected by Film Speed Selection Switch :

- a = Film speed No. F.09 (equivalent to ISO speed group "D", or Kodak Ultra speed)
- b = Film speed No. F.05 (equivalent to ISO speed group "E", or Kodak Ekta speed)
- c = Film speed No. F.02 (equivalent to ISO speed group "F")

Including these three, Model 096 can provide 16 different types of film speed and any three of them can be registered for easy selection.

If the doctor uses different speed of film, or prefers darker (or lighter) radiograph, substitute speed can be registered as follows:

1. While depressing technical switch⑯, turn on the main power switch①. Film type lamp "a" is lit, and F.09 is displayed in exposure time display window⑬.
Then, release technical switch.
2. By depressing ▲ switch (or ▼ switch), increase (decrease) film speed number until desired number is displayed. [Refer to Exposure Time Table on next page.]
3. Depress technical switch⑯, an electronic chime sounds and the selected film speed number is registered at film type "a".
4. Turn off the main power switch.
5. If different film speeds are to be registered at "b" and "c", depress "F" switch⑫ after step 1 above to light the appropriate film type lamp, and repeat steps 2 & 3.

TABLE 1 : FILM SPEED AND EXPOSURE TIME (REGULAR CONE)**(UNIT : SEC.)**

Patient Size	SMALL					MEDIUM					LARGE				
	Tooth	T1	T2	T3	T4	T5	T1	T2	T3	T4	T5	T1	T2	T3	T4
F. 00	0.02	0.03	0.04	0.05	0.07	0.03	0.05	0.06	0.08	0.12	0.04	0.06	0.08	0.10	0.15
F. 01	0.02	0.04	0.05	0.06	0.09	0.04	0.06	0.07	0.10	0.15	0.05	0.08	0.09	0.13	0.18
F. 02	0.03	0.05	0.06	0.07	0.11	0.05	0.08	0.09	0.12	0.18	0.06	0.10	0.11	0.15	0.22
F. 03	0.03	0.06	0.06	0.09	0.13	0.05	0.09	0.10	0.15	0.20	0.06	0.11	0.13	0.18	0.25
F. 04	0.04	0.07	0.08	0.10	0.16	0.06	0.11	0.13	0.17	0.25	0.08	0.14	0.16	0.20	0.31
F. 05	0.05	0.08	0.10	0.13	0.19	0.08	0.13	0.16	0.20	0.31	0.10	0.16	0.19	0.25	0.38
F. 06	0.06	0.10	0.12	0.16	0.22	0.09	0.16	0.19	0.25	0.36	0.11	0.19	0.24	0.31	0.44
F. 07	0.07	0.12	0.14	0.18	0.27	0.11	0.19	0.22	0.29	0.44	0.14	0.24	0.27	0.36	0.54
F. 08	0.08	0.14	0.17	0.22	0.33	0.14	0.22	0.27	0.36	0.54	0.17	0.27	0.33	0.44	0.66
F. 09	0.10	0.17	0.20	0.27	0.38	0.16	0.27	0.33	0.44	0.62	0.19	0.33	0.41	0.54	0.76
F. 10	0.12	0.19	0.24	0.31	0.47	0.19	0.31	0.38	0.50	0.76	0.24	0.38	0.47	0.62	0.93
F. 11	0.15	0.24	0.29	0.38	0.54	0.24	0.38	0.47	0.62	0.87	0.29	0.47	0.58	0.76	1.07
F. 12	0.17	0.29	0.33	0.47	0.66	0.27	0.47	0.54	0.76	1.07	0.33	0.58	0.66	0.93	1.32
F. 13	0.20	0.33	0.41	0.54	0.81	0.33	0.54	0.66	0.87	1.32	0.41	0.66	0.81	1.07	1.62
F. 14	0.24	0.41	0.50	0.66	0.93	0.38	0.66	0.81	1.07	1.51	0.47	0.81	1.00	1.32	1.86
F. 15	0.29	0.50	0.58	0.76	1.15	0.47	0.81	0.93	1.23	1.86	0.58	1.00	1.15	1.51	2.28

TABLE 2 : FILM SPEED AND EXPOSURE TIME (LONG CONE)**(UNIT : SEC.)**

Patient Size	SMALL					MEDIUM					LARGE				
	Tooth	T1	T2	T3	T4	T5	T1	T2	T3	T4	T5	T1	T2	T3	T4
F. 00	0.05	0.07	0.08	0.11	0.16	0.07	0.11	0.14	0.18	0.25	0.08	0.14	0.17	0.22	0.31
F. 01	0.05	0.08	0.10	0.14	0.19	0.08	0.14	0.16	0.22	0.31	0.10	0.17	0.19	0.27	0.38
F. 02	0.06	0.10	0.12	0.16	0.24	0.10	0.17	0.19	0.25	0.38	0.12	0.20	0.24	0.31	0.47
F. 03	0.07	0.12	0.14	0.19	0.27	0.11	0.19	0.22	0.31	0.44	0.14	0.24	0.27	0.38	0.54
F. 04	0.08	0.15	0.17	0.22	0.33	0.14	0.24	0.27	0.36	0.54	0.17	0.29	0.33	0.44	0.66
F. 05	0.10	0.17	0.20	0.27	0.41	0.17	0.27	0.33	0.44	0.66	0.20	0.33	0.41	0.54	0.81
F. 06	0.12	0.20	0.25	0.33	0.47	0.19	0.33	0.41	0.54	0.76	0.24	0.41	0.50	0.66	0.93
F. 07	0.15	0.25	0.29	0.38	0.58	0.24	0.41	0.47	0.62	0.93	0.29	0.50	0.58	0.76	1.15
F. 08	0.18	0.29	0.36	0.47	0.71	0.29	0.47	0.58	0.76	1.15	0.36	0.58	0.71	0.93	1.41
F. 09	0.20	0.36	0.44	0.58	0.81	0.33	0.58	0.71	0.93	1.32	0.41	0.71	0.87	1.15	1.62
F. 10	0.25	0.41	0.50	0.66	1.00	0.41	0.66	0.81	1.07	1.62	0.50	0.81	1.00	1.32	2.00
F. 11	0.31	0.50	0.62	0.81	1.15	0.50	0.81	1.00	1.32	1.86	0.62	1.00	1.23	1.62	2.28
F. 12	0.36	0.62	0.71	1.00	1.41	0.58	1.00	1.15	1.62	2.28	0.71	1.23	1.41	2.00	2.80
F. 13	0.44	0.71	0.87	1.15	1.73	0.71	1.15	1.41	1.86	2.80	0.87	1.41	1.73	2.28	3.00
F. 14	0.50	0.87	1.07	1.41	2.00	0.81	1.41	1.73	2.28	3.00	1.00	1.73	2.13	2.80	3.00
F. 15	0.62	1.07	1.23	1.62	2.44	1.00	1.73	2.00	2.62	3.00	1.23	2.13	2.44	3.00	3.00

[2] PRIORITY OF SELECTION

As factory installation, following selection lamps light when the main power switch is turned on:

Patient Size : Medium
Cone : Regular
Film Speed : "a"

If necessary, this priority can be changed as follows;

[For example, in pedodontics, patient size of "small" should be preferentially selected.]

1. While depressing technical switch⑬ between P(patient) and C(cone) switches, turn on the main power switch.
2. If "F.00" is displayed, release the technical switch. If "0.00" is displayed, turn off the main switch and repeat step 1.
3. Select one of three patient types (small, medium or large patient) which should be selected when main switch is turned on.
4. Select one of the cone types (regular or long cone) which should be selected when main switch is turned on.
5. Select one of three film speeds (a, b or c) which should be selected when main switch is turned on.
6. Depress the technical switch⑬, an electronic chime sounds twice and all settings at that time for patient, cone, film will be stored as primary selection.

[3] ELECTRONIC CHIME ON/OFF

As factory installation, electronic chime sounds when each switch is depressed. If preferred, this sound can be eliminated.

1. While depressing tooth selection switches T1 and T2 together, turn on the main power switch.
2. If "bu.1" is displayed, release T1 and T2 switches. If "0.00" is displayed, turn off the main switch and repeat step 1.
3. Depressing either ▲ or ▼ (③ or ④) switch adjacent to the exposure time display window until the display changes to "bu.0".
4. Then depress the technical switch⑬ between P and C switches, an electronic chime sounds twice and "bu.0" (buzzer off) setting will be stored in the memory on timer PCB.

NOTE : Exposure Warning Buzzer and alarm sound for error code can not be eliminated.

[4] TUBE CURRENT FEEDBACK ON/OFF

Micro computer in Belray Model 096 monitors tube current for each pulse of line frequency and this data is fed back to the output for filament of x-ray tube. By this system, highly stabilized tube current can be obtained and if tube current is out of the range, exposure is terminated immediately to prevent producing x-radiation out of specification.

This system is perfect to the user, but for the service personal it is difficult to find the cause when error occurs and exposure terminated instantly after the exposure started. Because, if exposure ends within a few pulses, no measurement can be done without storage oscillo scope.

In order to find the cause of error, tube current feed back system can be eliminated. In this mode, tube current is not monitored and exposure is continued for setting period even if the tube current is out of range.

▲ CAUTION:

AS ERROR FUNCTION OF TUBE CURRENT IS KILLED IN "071" MODE, BE CAREFUL NOT TO DAMAGE THE TUBE HEAD AND POWER GENERATING PCB.

1. While depressing tooth selection switches T4 and T5 together, turn on the main switch.
2. If "096" is displayed, release T1 and T2 switches. If "0.00" is displayed, turn off the main switch and repeat step 1. "096" means the value of tube current is fed back to the output of filament and tube current error appears when tube current is out of the range.
3. By depressing either ▲ or ▼ switch adjacent to the exposure time display window, display changes to "071". "071" means the value of tube current is not fed back to the filament and tube current error never appears even if the tube current is out of the range.
4. Then depress the technical switch between P and C switches, an electronic chime sounds twice and the setting displayed at that time will be stored in the memory on timer PCB.
5. After checking the cause of tube current error, above setting must be reset to "096".

WARNING: IF BELRAY MODEL 096 IS USED IN 071 MODE, IT CANNOT BE ENSURED BEING IN COMPLIANCE WITH THE STANDARD.

[5] CONFIRMATION OF SETTINGS

All data stored in the memory on the timer PCB can be reviewed. This function is only for observing status of the unit. Data cannot be changed in this mode.

1. While depressing switches T5 (tooth type) and C (cone type) together, turn on the main switch.
2. If "L.○○" or "P○.○" is displayed, release T5 and C switches. If "0.00" is displayed, turn off the main switch and repeat step 1.
3. By depressing ▲ switch adjacent to the exposure time display window, display changes as follows.

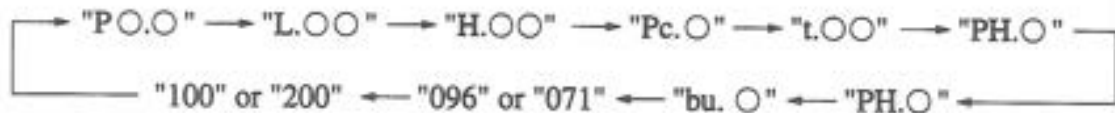

4. "P○.○" is the version number of software for micro computer on timer PCB and is displayed only for the version after 2.4.
5. "L.○○" and "H.○○" are settings for minimum and maximum line voltages. For changing these settings, true sine wave ac power supply is required. (These settings cannot be changed in the field.)
6. "Pc.○" is setting for line voltage measurement error. "Pc.0" is the factory setting. Refer to page 20 for detail.
7. "t.○○" is setting for reference of tube current. A special instrument is necessary for setting this value and adjustment in the field is not possible.
8. "PH.○" and "EP.○" are settings for tube current adjustment. Former value is for the tube current at the beginning of exposure and latter value is for the tube current at stabilized period of exposure. These values can be adjusted automatically or manually (page 17).
9. "bu.○" is setting for electronic chime. Factory setting is "bu.1". Refer to page 10.
10. "096" / "071" is setting for tube current feed back. This setting should be "096" in normal use.
11. "100" / "200" is setting for rated line voltage. For 100, 110 and 120Vac, "100" should be selected. For 220, 230 and 240Vac, "200" should be selected.

SECTION 3: DESCRIPTION FOR FUNCTIONS

[1] GENERAL

The Belmont Belray Model 096 consists of three major components: the control box, tube head and balance arm assembly. Because of its modular design, the control box can be readily remotely located to accommodate room design and radiation control requirements.

The control box consists of power generator, timing and control circuits. Since Belray 096 utilizes the AVR (automatic voltage regulator) circuit instead of step up/down transformer to compensate line voltage fluctuation and also tube current is controlled by feed back system, quality of x-radiation is quite stable over whole range of exposure time from 1 pulse to 3 seconds. Precise and short exposure time enables Belray 096 to be used with the digital image receptor.

The tube head is a vacuum-sealed oil cooled unit with a high voltage transformer and a x-ray tube self-contained. No high voltage line runs outside of the head. Except for mechanical repairs (yoke bearings, etc.) or external wiring problems, tube head must be replaced as a unit. It can not be opened in the field.

The counterbalanced arms provide a precisely balanced long reach support for the x-ray head. These arms contain highly tensioned springs which can cause serious injury if accidentally released. **DO NOT ATTEMPT TO DISASSEMBLE THESE ARMS IN THE FIELD.**

[2] AUTOMATIC VOLTAGE REGULATOR

(1) GENERAL

1. Model 096 is equipped with the automatic voltage regulator (AVR) in the control box. Purpose for this function is as follows.
 - a. As the line voltage fluctuation (including voltage drop during exposure) is absorbed, stabilized voltage is supplied to the high voltage transformer and filament transformer. As a result, output x-radiation is highly stabilized.
 - b. If auto transformer is used to compensate the voltage fluctuation, there always exists some voltage error because of stepping adjustment. AVR in Model 096 is using Field Effect Transistor to adjust the voltage, so no voltage error exists principally.
 - c. When line voltage fluctuates, in case of auto-transformer operator must adjust the voltage by changing the tap of transformer. AVR circuit adjusts the voltage automatically and requires no operation to user.
 - d. The outer dimensions and weight of control box can be reduced by eliminating a heavy auto transformer.
2. Block diagram of AVR circuit is described in FIGURE 1.
3. Power FET (field effect transistor) is controlled as the voltage of reference sine wave and the voltage divided from AVR output becomes the same value and the same wave form.
4. Output voltage of AVR is 94 ± 0.5 Vac.

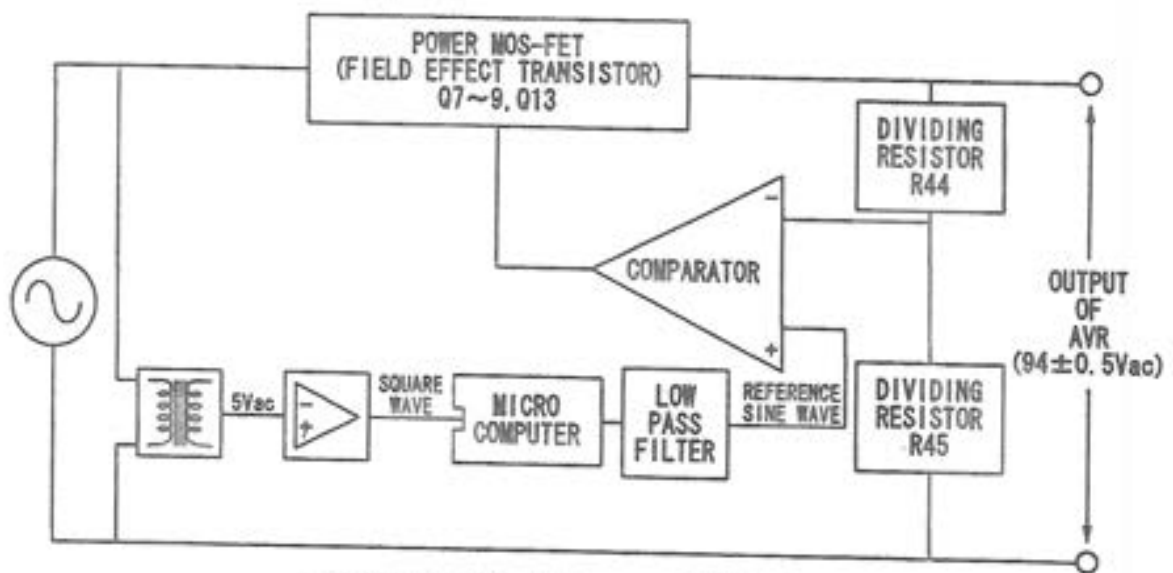

FIGURE 1. Block diagram of AVR circuit

(2) REFERENCE SINE WAVE

1. Reference sine wave is generated from the square wave through low pass filter. Since the phase is delayed after the filter, micro computer adjusts the phase of square wave as the phase of reference sine wave becomes the same as the line voltage.
2. Variable resistors RV1_4 within the low pass filter circuit adjusts various parameters of reference sine wave as follows.

RV1 : Balance for positive and negative voltage of reference sine wave

RV2 : Amplitude of reference sine wave for line frequency of 60 Hz

RV3 : Amplitude of reference sine wave for line frequency of 50 Hz

RV4 : Phase of reference sine wave

WARNING: As the exclusive instrument is necessary for adjustment beside the amplitude, power generating PCB should be replaced if RV1, RV3 or RV4 is rotated in the field.

(3) DIVIDING RESISTOR

1. AVR voltage is divided by resistor, since the voltage of AVR output is too high to be used in the control circuit directly.
2. Resistors R44 (1k Ω) and R45 (10k Ω) divide AVR voltage. Variable resistor RV2 is connected in parallel to R44.

(4) FET

1. Four power MOS FETs (Q7_9, Q13) are used to control the positive voltage of AVR.
2. To reduce the power consumption in FETs, power resistors are inserted in series to Q7 and Q13. Also diodes are inserted to the gate terminal of Q8 and Q9.
3. Bi-polar transistors are used to control the negative voltage of AVR.

(5) OVER CURRENT PROTECTION

1. Current sensing resistor R26·R64 (0.05 Ω) are used in series to FETs. If voltage across these resistors becomes higher than approx. 2.7V, all FETs and bi-polar transistors turn off and "E.04" is displayed in the exposure time display window.
2. R18 (0.47 Ω) is used in series to bi-polar transistors. If voltage across this resistor becomes higher than approx. 2.7V, all FETs and bi-polar transistors become off and "E.04" is displayed in the exposure time display window.

[3] PRIMARY CIRCUIT OF HIGH VOLTAGE TRANSFORMER

1. Back reducer (parallel circuit of resistor and diode to reduce the reverse voltage of x-ray tube) and switching device (Triac) are added to AVR output and applied to the primary of high voltage transformer.
2. Both poles of voltage applied to the primary of high voltage transformer are turned on and off by Triac and relay. Relay activates soon after the exposure switch is depressed and Triac turns on after the pre-heating period is finished and at zero crossing timing of the line voltage.

[4] PRIMARY CIRCUIT OF FILAMENT TRANSFORMER

(1) CIRCUIT AND OPERATIONAL TIMING

1. Parallel circuit of resistor R46 and transistor Q12 is added in series to the AVR circuit and applied to the primary circuit of filament transformer.
2. As Triac is not inserted in this circuit, voltage is applied to the filament transformer if the relay mentioned above comes on.
3. Triac in the primary circuit of high voltage transformer comes on at zero crossing point of 49th pulse of line frequency after the relay comes on, and x-radiation is started from this moment. This means the pre-heating period is fixed to 0.8 seconds.

(2) ADJUSTMENT OF OUTPUT

1. The length of time period during the transistor Q12 makes the voltage across R46 ($82\ \Omega$) be shortened or opened decides the power to the filament of x-ray tube. To protect the filament, off period of Q12 is adjusted around the peak point of sine wave of line voltage.
2. The longer the off period of Q12 becomes, the primary voltage becomes lower and tube current decreases.
3. Although off period of Q12 during pre-heating is adjusted by PH value, off period during exposure cannot be adjusted manually as the micro computer adjusts it automatically for each pulse according to the tube current at that time. In this system, tube current during exposure can not be adjusted. To improve this, changing EP value makes the reference value for tube current to be increased or decreased.
4. After all, tube current at the beginning of exposure can be adjusted by PH setting and tube current at stabilized period of exposure is adjusted by EP setting. Both PH and EP have 16 stages, 0_F (A=10, F=15). Higher setting makes tube current increased.
5. In case of 071 mode, off period of Q12 is constant during exposure as the filament is not controlled by feed back system. This constant value is adjusted by EP setting.

(3) OVER CURRENT PROTECTION

1. Over current protection in the AVR circuit works with relatively high current. As the rated current for primary circuit of filament transformer is approx. 0.2 Aac, this over current protection circuit will not work even when the abnormal condition occurs in the filament circuit.
2. Current sensing resistor R11 ($0.33\ \Omega$) is inserted in the primary circuit of filament transformer. When the voltage across this resistor makes LED of photo coupler PI7 on, "E.04" is displayed and output voltages to the high voltage transformer and filament transformer are terminated instantly.

[5] AUTOMATIC TUBE CURRENT CONTROL

(1) CIRCUIT

1. Tube current fed back from tube head is converted into voltage by the resistors R61 and R88 (totally 500 Ω) on power generating PCB.
2. This voltage is integrated for each pulses of line frequency by the operational amplifier and applied to the micro computer on timer PCB.

(2) STABILIZING METHOD OF TUBE CURRENT

1. If the tube current of certain pulse measured by micro computer is lower than the rated value (10mA), the off period of Q12 of next pulse is decreased. Shorter off period makes the output voltage for filament increased and as the result, tube current is increased.
2. If measured tube current is higher than the rated value, off period of next pulse is increased. Longer off period makes the output voltage for filament decreased and as the result, tube current is decreased.
3. This feed back control for filament is used during the exposure only. During pre-heating period, output for filament transformer is constant because of no tube current.

SECTION 4: ADJUSTMENT

[1] AVR VOLTAGE

Output voltage of Automatic Voltage Regulator circuit can be measured and adjusted as follows. If AVR voltage is adjusted, tube current adjustment must be done after that.

1. Prepare a digital multimeter capable to measure 94 Vac with accuracy of 1 % or better.
2. While depressing the T2, T3 and P (patient) switches, turn on the main switch. The letters "Adj" should appear in the exposure time display window.
3. Set the range of digital multimeter at 200Vac. Open the front panel of the control box and place one lead of multimeter to terminal #3 (blue wire) of terminal block in the control box and the other lead on "TP2", a wire ring test terminal in the center about 1/3 of the way up the power generating PCB. (Refer to FIGURE 2.)
4. Press the exposure switch to get a reading. It should be $94.0 \pm 0.5\text{Vac}$.

NOTE: TO PREVENT OVERHEATING OF THE FILAMENT, RELEASE THE EXPOSURE SWITCH AS SOON AS POSSIBLE AFTER VOLTAGE IS READ.

5. If the AVR voltage is higher than this range, then adjust RV2, a pot just to the right of TP2, counterclockwise very slightly and repeat step 4 to get reading. Repeat until an AVR voltage setting becomes within the range of $94.0 \pm 0.5\text{Vac}$.

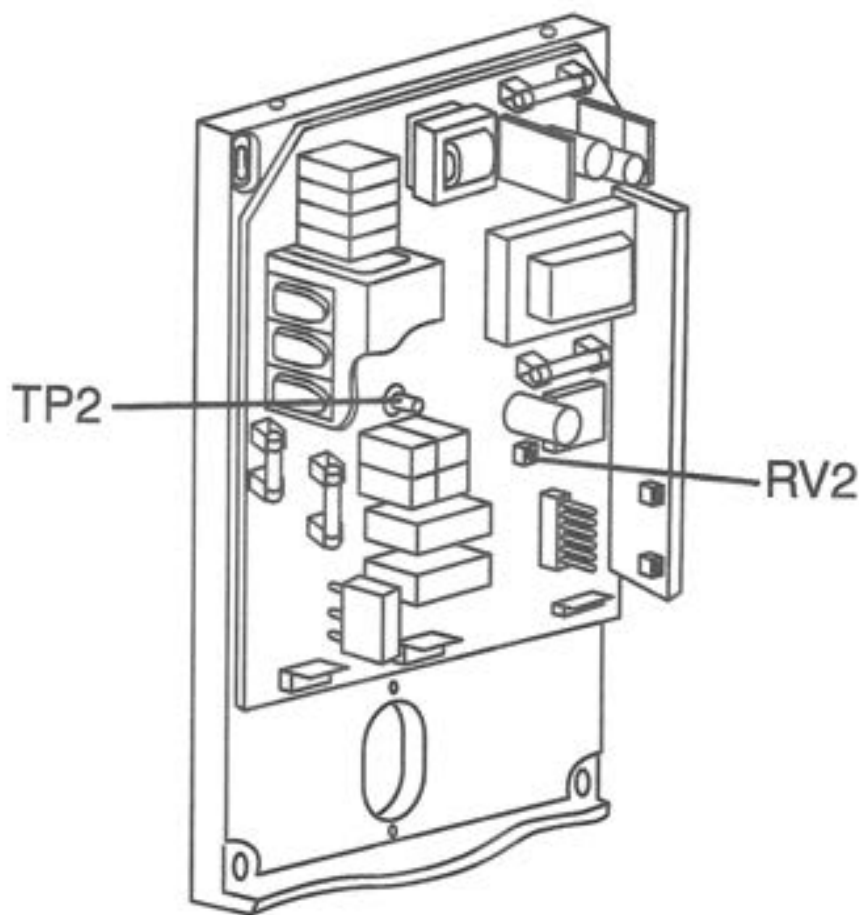

FIGURE 2. TP2 and RV2 on the Power Generating PCB

[2] INSPECTION OF TUBE CURRENT

Model 096 has two types of self measuring function for tube current, i.e., auto mode and manual mode. Tube current can also be measured directly by multimeter.

In auto mode, both tube current at the beginning and at stabilized period of exposure are checked and adjusted automatically, although the values of tube current are not displayed.

In manual mode, the value of tube current is displayed at the exposure time display window, but separate exposures are necessary to know the tube current at the beginning and at stabilized period of exposure. If tube current is out of range, additional operations for adjustment are also necessary in this mode.

In case of two methods mentioned above, tube current is measured by the micro computer on the timer PCB. The last method is direct measurement of voltage. Tube current is converted into voltage by resistors R61 and R88 (totally 500Ω) on power generating PCB. The voltage across these resistors becomes 5 Vdc, when tube current is 10 mAdc. With this method, only the tube current at stabilized period of exposure can be measured.

Auto mode is recommended for post installation confirmation and periodic maintenance.

a. Auto mode

1. While depressing tooth selection switches T1, T4 and T5 together, turn on the main power switch.
2. Exposure time "0.50" is displayed and ready light is on. (If not, turn off main power switch and repeat step 1.) Then release T1, T4 and T5 switches.
3. Make an exposure by depressing hand exposure switch.

▲WARNING: X-RADIATION IS GENERATED FOR 0.5 SECONDS.

4. If "Fin" is displayed at the exposure time display window, tube current at the beginning of exposure is within the range of 10 ± 0.5 mA and tube current at the stabilized period of exposure is within the range of 10 ± 0.25 mA. In this case, it is not necessary to proceed further.
5. If "PH.○" and "EP.○" are displayed alternately, leave the unit for about 30 seconds until display returns to "0.50". Then make an exposure again and confirm that "Fin" is displayed.
6. Repeat step 5. until "Fin" is displayed.

b. Manual mode

Model 096 x-ray has the function displaying the tube current of the last pulse of the exposure at the exposure time display window. By this function, the tube current at the beginning and at the stabilized portion of the exposure can be measured.

b-1. Tube current at the beginning of exposure

1. Turn on the main power switch.
2. Set the exposure time at 0.02 second by the manual adjusting switch adjacent to the exposure time display window. (0.02 second equals to 1 pulse and last pulse of 1 pulse exposure equals to the first pulse of exposure.)
3. Make an exposure and keep the exposure switch depressed even after the exposure is over. Press the technical switch between the patient and cone selection switches.
4. Tube current of the first pulse of the exposure is displayed at the exposure time display window, while the exposure switch is kept depressed.
5. This value should be 10 ± 2 mA. If it is out of this range, perform the PH adjustment. (Page 21)

b-2. Tube current at the stabilized portion of the exposure

1. Turn on the main power switch.
2. Set the exposure time at 0.5 seconds by the manual adjusting switch adjacent to the exposure time display window.
3. Make an exposure and keep the exposure switch depressed even after the exposure is over. Press the technical switch between the patient and cone selection switches.
4. Tube current of the last pulse of 0.5 second exposure is displayed at the exposure time display window while the exposure switch is kept depressed.
5. Indicated tube current should be 10 ± 1 mA . If it is out of this range, perform the EP adjustment. (Page 21)

c. Direct measurement

1. Prepare a multimeter capable to measure 5 Vdc with 1% accuracy within 1 second.
2. Turn off the main switch of control box.
3. Open the front panel of control box and confirm the resistance between terminals #6 (yellow) and #7 (gray) of terminal block in the control box is 500Ω . (Refer to page 24.)
4. Set the range of multimeter to measure 5Vdc.
5. Connect the leads of multimeter to terminals #6 and #7 of terminal block in the control box.
6. Turn on the main switch.
7. Set the exposure time to 2 seconds.
8. Make an exposure and read the multimeter during exposure.
WARNING: X RADIATION IS GENERATED FOR 2 SECONDS.
9. Multiplying the voltage reading by 2 becomes tube current. Ex. If reading is 4.8 Vdc, then tube current is $4.8 \times 2 = 9.6$ mA. This value is the tube current at the stabilized portion of the exposure. (By this method, tube current at the beginning of exposure cannot be measured.)

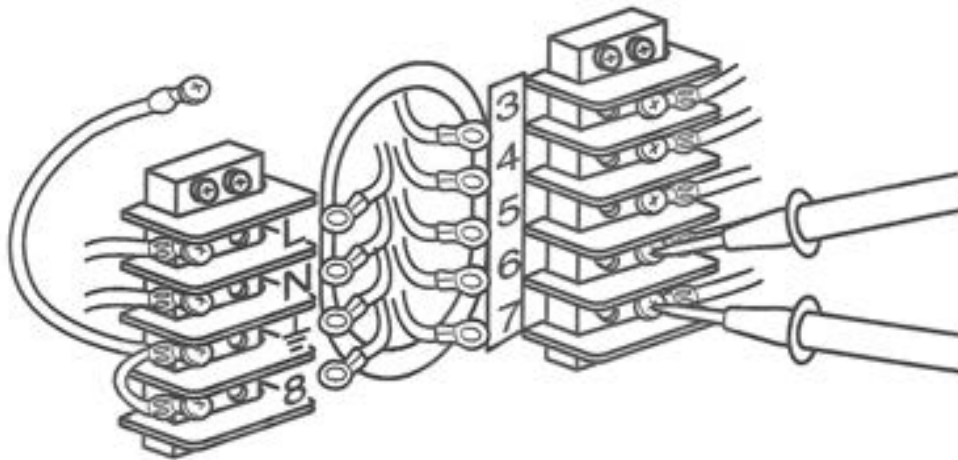

FIGURE 3. Direct measurement of tube current at terminal #6 and #7

[3] ADJUSTMENT OF TUBE CURRENT

Tube current at beginning of exposure can be adjusted by PH setting and tube current at stabilized portion of exposure can be adjusted by EP setting. (Refer to page 14.)

If tube current is checked by auto mode as mentioned on page 17 and tube current is out of range (10 ± 0.5 mA for beginning, 10 ± 0.25 mA for at stabilized portion of exposure), successive exposure sets PH and EP to adequate value automatically.

If tube current is checked by manual mode as mentioned on page 17, PH and EP should be adjusted manually as follows.

(1) MANUAL SETTING METHOD FOR PH

1. Check tube current at beginning of exposure by manual mode as page 17. If tube current is out of the range of 10 ± 0.5 mA, perform following adjustment.
2. While depressing P (patient), C (cone), F (film) switches, turn on the main switch.
3. If "PH.○" is displayed, release P, C, F switches. ○ is the PH value presently programed. If "0.00" is displayed, turn off the main switch and repeat step 2.
4. If tube current is lower than 9.5 mA at step 1, press ▲ switch adjacent to the exposure time display window and PH value displayed will be increased. If tube current is higher than 10.5 mA, press ▼ switch to decrease the PH value. PH has 16 kinds of values, 0 _ F. Next to 9 is A and consequently F equals to 15.
5. Press technical switch between P and C switches to memorize the PH value displayed to the memory on timer PCB. If value is stored, electronic chime will sound twice.
6. Turn off the main switch and check the tube current at beginning of exposure again. If tube current is within 10 ± 0.5 mA, PH adjustment is finished. If tube current is still out of the range, repeat step 2_6 above.

(2) MANUAL SETTING METHOD FOR EP

1. Check tube current at stabilized portion of exposure by the manual mode (page 17) or by the direct measurement (page 18). If tube current is out of the range of 10 ± 0.5 mA, perform following adjustment.
2. While depressing P (patient), C (cone), F (film) switches, turn on the main switch.
3. If "PH.○" is displayed, release P, C, F switches. If "0.00" is displayed, turn off the main switch and repeat step 2.
4. Press T2 switch then display changes to "EP.○". ○ is the EP value presently programed.
5. If tube current is lower than 9.5 mA at step 1, press ▲ switch adjacent to the exposure time display window and EP value displayed will be increased. If tube current is higher than 10.5 mA, press ▼ switch to decrease EP value. EP has 16 kinds of values as PH.
6. Press technical switch between P and C switches to memorize the EP value displayed to the memory on timer PCB. If value is stored, electronic chime will sound twice.
7. Turn off the main switch and check the tube current at stabilized portion of exposure again. If tube current is within 10 ± 0.5 mA, EP adjustment is finished. If tube current is still out of the range, repeat step 2_7 above.

[4] ADJUSTMENT OF LINE VOLTAGE MEASUREMENT ERROR

Line voltage is monitored by micro computer and if it is out of the operable range (108_132Vac), the ready lamp on front panel turns off and exposure is inhibited. The form of line voltage should be sine wave. Since the peak voltage of this sine wave is converted to measurable voltage and applied to micro computer, there exists a measurement error if the wave form is not perfect sine wave.

In case that measured rms (Root Mean Square) voltage of power line by a precise multimeter is within the range of 108 ~ 132Vac but the ready lamp on front panel doesn't come up, measured voltage by micro computer can be shifted by $\pm 3\%$ as follows.

1. While depressing T2, T3 and T4 switches, turn on the main power switch.
2. If "Pc.○" is displayed, release T2, T3 and T4 switches. Pc means Power wave form Compensation and ○ is the setting number 0 ~ 2. If "0.00" is displayed, turn off the main switch and repeat step 1.
3. Meaning of Pc value is as follows.
Pc.0 : No compensation is applied. ← initial setting from factory
Pc.1 : Measured voltage by micro computer is decreased by 3 %.
Pc.2 : Measured voltage by micro computer is increased by 3 %.
4. If multimeter indicates 129 ~ 132 Vac and ready lamp doesn't come on, set to "Pc.1" by depressing ▲ switch adjacent to the exposure time display window.
5. If multimeter indicates 108 ~ 111 Vac and ready lamp doesn't come on, set to "Pc.2" by depressing ▼ switch adjacent to the exposure time display window.
6. After the display becomes suitable value, press the technical switch between P and C switches to store the value in the memory on timer PCB. If the setting is stored, electronic chime will sound twice.
7. Turn off the main switch and wait for a while and turn it on again.
8. If the ready lamp is still off even the multimeter indicates 108 ~ 132Vac, the wave form of line voltage is far from sine wave by more than 3% or transformer on the power generating PCB or timer PCB might be defective.

SECTION 5: PERIODIC INSPECTION AND ADJUSTMENT

Following inspections and adjustments should be performed after installation, when parts are changed, and once every 6 months by a trained service technician to ensure that the x ray unit is functioning with the manufacturer's specifications and remains in compliance with the standard.

[1] ELECTRICAL INSPECTION AND ADJUSTMENT

(1) POWER SUPPLY VOLTAGE

Power supply voltage must be within the operable range of 108~132 Vac. Confirm the power supply voltage before turning the unit on.

1. Open the front panel of control box by loosening two screws on top of control box.
2. Set the range of digital multimeter at 200Vac, connect probes of multimeter to L and N terminals of terminal block in the control box.
3. Confirm that the reading is 120V \pm 10% (108~132Vac).

(2) CONFIRMATION OF TUBE CURRENT

Confirm the tube current at beginning and at stabilized portion of exposure by auto mode as page 19.

(3) EXPOSURE WARNING BUZZER AND LAMP

a. Exposure warning buzzer

Make an exposure and confirm that the exposure warning buzzer located within the control box is activated during the entire exposure.

b. Exposure warning lamp

Make an exposure and confirm that the exposure warning lamp illuminates during the exposure. Exposure warning lamp is located on the front panel of the control box.

(4) LINE VOLTAGE REGULATION

1. Make sure that a main power switch is "OFF".
2. Open the front panel of control box by loosening two screws on top of the control box.
3. Set the range of digital multimeter at 200Vac, connect probes of multimeter to L and N terminals of terminal block in the control box.
4. Turn on the main power switch, and set the exposure time at 2.00 seconds by ▲ switch adjacent to the exposure time display window.
5. Record the no-load line voltage (VN) indicated by the multimeter before the exposure.
6. Make an exposure and record the load voltage (VL) indicated by the multimeter during the exposure.

▲ WARNING: X-RADIATION IS GENERATED FOR 2 SECONDS.

NOTE: Read the multimeter after the value is stabilized (about one second after the exposure starts.)

7. Calculate line voltage regulation R (%) in the formula below.

$$R = \frac{VN - VL}{VL} \times 100 \quad \text{Record this value in "Assemblers Installation Report".}$$

R must not exceed the range of 2~5%. If it is greater than 5%, the size of the power supply wires must be increased. Refer to the power supply requirements on page 5 of the model 096 installation instructions to determine the correct wire size necessary.

[2] MECHANICAL INSPECTION

(1) ARM ASSEMBLY

1. Extend the balance arms to the maximum reach and keep it straight to the horizontal arm.
2. Set the horizontal arm at right angle to the wall and confirm neither horizontal arm nor balance arm drift. (FIGURE 4)
3. Make the horizontal arm parallel to the wall and confirm again.
4. If either arm drifts, adjust the brake screw or correct the position of the wall plate according to the phenomenon. (Refer to page 13 of 096 installation instructions.)
5. Place the balance arm assembly into position.
6. If either balance arm drifts either higher or lower from the set position, remove the spring adjustment covers and with the supplied wrench adjust the tension balance arm assemblies. (FIGURE 5)

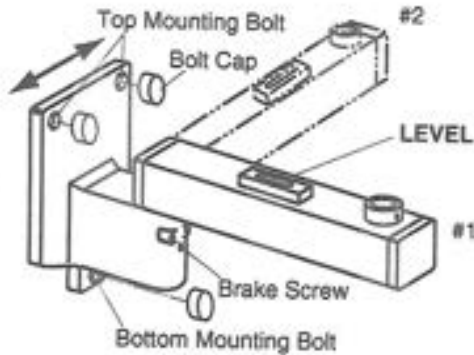

FIGURE 4

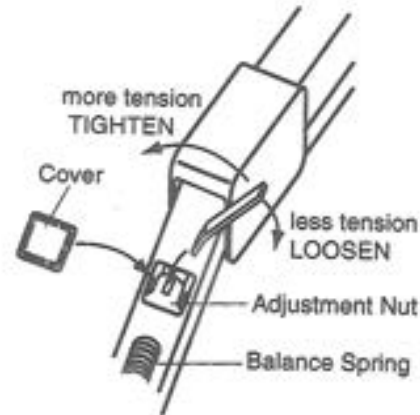

FIGURE 5

(2) HEAD ASSEMBLY

1. Place the head into working position.
2. If head drifts from the set position, adjust the brake screws according to the following procedures.
 - a. Remove the yoke outside cover by loosening cover screw. (FIGURE 6)
 - b. Adjust 6 brake screws using philip's screw driver.
 - c. After adjustment, re-attach the yoke outside cover.

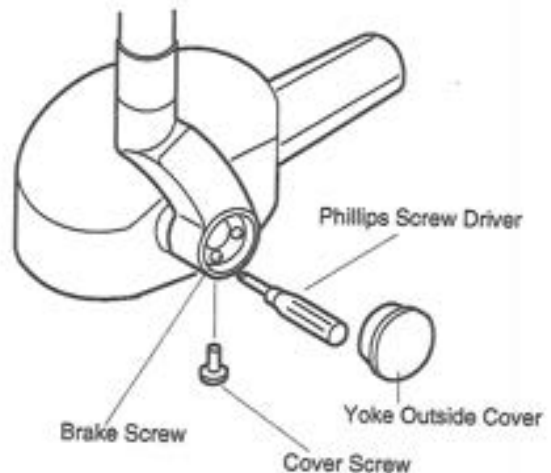

FIGURE 6

(3) MECHANICAL SAFETY

1. The wall plate, if used, should be checked to confirm its secure attachment to the wall.
2. The arm mounting bracket should be checked to confirm its secure attachment to the wall mounting plate or, to the wall.
3. Check to insure the horizontal arm is not raising up and out of the arm mounting bracket. This should be observed routinely by treatment room personnel.

SECTION 6: COMPONENT VERIFICATION

[1] CONTROL BOX

(1) POWER GENERATING PCB

a. AVR voltage

1. Output voltage of Automatic Voltage Regulator circuit should be measured and adjusted as page 16.
2. If AVR voltage cannot be adjusted to $94 \pm 0.5 \text{Vac}$, cables between the control box and head are broken or power generating PCB or timer PCB is defective.

b. Triac circuit

1. Set the range of multimeter to 200Vac and open the front panel of control box.
2. Connect the leads of multimeter to #3 (blue wire) and #4 (brown wire) terminals of terminal block in the control box.
3. Turn on the main switch of the control box. Voltage reading should be 0Vac.
4. Set the exposure time to 2.00 seconds and make an exposure. Voltage reading should be 0 Vac during preheating time (0.8 seconds) and 80~90Vac during the exposure, then returns to 0Vac after the exposure.
5. If the voltage reading becomes 80~90Vac during the pre-heating time, triac TH1 is defective (short circuited). In this case, power generator PCB should be replaced.

c. Output for filament transformer

When no trouble exists, output voltage for filament transformer can be measured across the terminals #3 (blue wire) and #5 (red wire) of terminal block in the control box with 2 seconds exposure. This voltage is normally $90 \pm 5 \text{Vac}$.

If no voltage is supplied to the filament transformer, no tube current flows and error code "E.07" appears. Same error code appears when the filament of x-ray tube is defective. When this error code appears, exposure terminates immediately and it is not possible to measure the output voltage in this short period. So, it is difficult to distinguish whether the cause is in the control box or in the head.

In 071 mode, tube current is not measured by micro-computer and as a result no error code for tube current appears and exposure continues according to the exposure time setting. Following procedure is for this situation. After measurement the mode must be reset to 096.

1. While depressing T4 and T5 switches, turn on the main switch. If "096" is displayed at the exposure time display window, release T4 and T5 switches.
2. Press either one of manual exposure time setting switches and make the display to show "071".
3. Press the technical switch between the patient and cone selection switches. If buzzer beeps twice quickly, "071" setting is memorized. Turn off the main switch.
4. Turn on the main switch again. Set the exposure time to 1 seconds.
5. Set the range of multimeter to 200 Vac.
6. Open the front panel of control box and connect the leads of multimeter to the terminals #3 (blue wire) and #5 (red wire) of terminal block in the control box. Reading should be 0 Vac before the exposure.
7. Make an exposure. Reading of multimeter should be $90 \pm 5 \text{Vac}$. If the voltage is out of this range, replace the power generator PCB.

8. Turn off the main switch.
9. While depressing T4 and T5 switches, turn on the main switch. If "071" is displayed at the exposure time display window, release T4 and T5 switches.
10. Press either one of manual exposure time setting switches and make the display to be "096".
11. Press the technical switch between the patient and cone selection switches. If buzzer beeps twice quickly, "096" setting is memorized. Turn off the main switch.

d. Resistor for tube current measurement

Micro-computer measures the tube current by voltage. Tube current is converted into voltage by the $500\ \Omega$ resistor on the power generator PCB.

1. Turn off the main switch of control box.
2. Select the range of multimeter to measure $500\ \Omega$ resistor.
3. Connect the leads of multimeter to #6 (yellow wire) and #7 (gray wire) terminals of terminal block in the control box.
4. Reading should be $500 \pm 10\ \Omega$.
5. If the reading is out of this range, check the resistance between the #1 and #3 terminals of CN5 on the power generator board after the CN5 connector is disconnected.
6. If the resistance is still out of the range, resistors R61 and R88 on the power generator PCB are defective.

(2) TIMER PCB

If one of the following phenomena is observed, timer PCB is defective.

1. Nothing appears on the exposure time display window, when the power is turned on.
2. Non of LEDs for patient, cone and film setting is illuminated.
3. No beeper sound is heard, during the exposure is made and the exposure warning lamp is illuminated.

[2] TUBE HEAD

(1) FILAMENT OF X RAY TUBE

1. If filament of x-ray tube is defective, no tube current flows and as a result error code "E.07" appears and exposure stops immediately. In this condition it is not possible to measure any voltage.
2. Same procedure should be taken as the verification of power generator PCB - filament output (page 23).
3. If voltage reading is $90 \pm 5\ \text{Vac}$ between #3 and #5 terminals in the control box during exposure, measure the voltage between the terminals #3 (blue wire) and #5 (red wire) of the terminal block in the head yoke.
4. If no voltage is measured here during exposure, then wires between the control box and head should be checked.
5. If this voltage is also $90 \pm 5\ \text{Vac}$ during exposure, then remove the red wire of arm cable from #5 terminal in the head yoke. Set the multimeter to measure $200\ \text{mAac}$ and insert the meter between this red wire and #5 terminal in the head yoke.
6. Reading should be $0\ \text{mAac}$ before the exposure and approximately $180\ \text{mAac}$ during exposure. If reading is significantly lower than this value (ex. $20\ \text{mAac}$), the filament of x-ray tube is defective.
7. After measurement the mode must be changed back to "096".

(2) INSUFFICIENT OIL

1. Shake the tube head in a silent room. If oil shortage sound (sloshing) is heard, head should be replaced.
2. If oil leakage is observed, head should be replaced.

(3) INTERNAL SHORT

1. If error code "E.04" appears when exposure is made, over current condition is exist or power generator PCB is defective.
2. Disconnect the head and change the mode to "071". (Refer to page 10.)
3. If error code "E.04" doesn't appear during exposure, the tube head is internally shorted and should be replaced.
4. If error code "E.04" still appears, short circuit in the arm wiring or defect of power generator PCB is suspected.
5. Disconnect the arm cable at the terminal block in the control box and make an exposure. If error code "E.04" doesn't appear during exposure, short circuit exists in the arm wiring.
6. If error code "E.04" still appears, power generator PCB is defective.

[3] WIRING BETWEEN HEAD AND CONTROL BOX

(1) WIRE SIZE

Six conductor 12 AWG is recommended for wire run distances up to 50 feet. For wire runs between 50 and 75 feet, 10 AWG is required. For wire run distances in excess of 75 feet, 8 AWG is required.

(2) CONTINUITY

Mis-wiring or short circuited wire can destroy the tube head.

1. Turn off the main switch.

2. Remove the head from the arm.

WARNING: AS THE BALANCE ARM IS HIGHLY TENSIONED , IT IS NECESSARY TO PLACE THE HEAD AT MAXIMUM HEIGHT BEFORE REMOVING THE TUBEHEAD.

3. Open the front panel of control box and disconnect the arm cable from the terminal block.
4. Check the continuity for each wire and make sure that each wire does not have continuity between any other wires.

SECTION 7: ERROR CODE

When abnormal condition exists in the unit, or malfunction occurs, error code is displayed in exposure time display window. Possible causes, check points and solutions for each error code are described below.

CODE	MEANING	POSSIBLE CAUSE	CHECK POINT	SOLUTION
E.00	Exposure switch is released before the exposure terminates.	a. Operator's fault.		Teach operator to release the exposure switch after the exposure lamp turns off.
		b. Exposure switch or the coil cord for exposure switch is defective. Operator's fault.	Disconnect CN4 from power generating PCB and check the continuity during the exposure switch is on.	If defect is found, exchange the exposure switch and cord. Teach operator to take a "wait" interval of 60 times of exposure time between successive exposures.
E.01	Exposure switch is depressed within 10 sec. from previous exposure.	a. Line voltage is less than 108 Vac.	Measure the incoming voltage between terminal L and N of terminal block in the control box.	If line voltage is less than 108 Vac, correct the voltage with additional step-up transformer.
		b. Wave form of line voltage is differ from sine wave.	Measure the incoming voltage between terminal L and N of terminal block in the control box.	If line voltage is close to 108 Vac but over 108 Vac, set Pc.0 setting to Pc.2. (Press T2-T3-T4 and power switch for Pc.0 setting mode. Refer to page 20.)
E.02	Line voltage is less than 90 % of rated voltage.	c. Voltage setting on the memory chip in the control box is not suitable.	Adjustment in the field is difficult, as the voltage slider is necessary to adjust L.O.O and H.O.O settings.	Send the control box to Belmont to adjust L.O.O and H.O.O settings.
		a. Line voltage is more than 132 Vac.	Measure the incoming voltage between terminal L and N of terminal block in the control box.	If line voltage is more than 132 Vac correct the voltage with additional step-down transformer.
		b. Wave form of line voltage is differ from sine wave.	Measure the incoming voltage between terminal L and N of terminal block in the control box.	If line voltage is close to 132 Vac but less than 132 Vac, set Pc.0 to Pc.1. (Press T2-T3-T4 and power switch for Pc.0 setting mode. Refer to page 20.)
E.03	Line voltage is more than 110% of rated voltage.	c. Voltage setting on the memory chip in the control box is not suitable.	Adjustment in the field is difficult, as the voltage slider is necessary to adjust L.O.O and H.O.O settings.	Send the control box to Belmont to adjust L.O.O and H.O.O settings.

CODE	MEANING	POSSIBLE CAUSE	CHECK POINT	SOLUTION
E.04	Excess line current during exposure.	a. Tube head is internally shorted.	Disconnect the tube head and make an exposure.	If E.07 comes, the tube head may be defective. Change the tube head.
		b. Cables between the control box and head are short circuited.	If E.04 still comes when the tube head is disconnected, disconnect the wires from the terminal 3-4-5-6-7 of the terminal block in the control box and make an exposure.	If E.07 comes, cables between the control box and head may be short circuited. Find the defective portion and correct it.
		c. Power generating PCB is defective.	Disconnect the wires from the terminal 3-4-5-6-7 of the terminal block in the control box and make an exposure.	If E.04 still comes, power PCB may be defective. Change the power generating PCB.
E.05	Tube current of the last pulse is less than 7.5 mA.	AVR voltage is too low.	Measure the voltage between TP2 on the main PCB and terminal #3 of the terminal block in the control box, when the exposure switch is pressed in the "Adj" mode. (Press P-T2-T3 and power switch for "Adj" mode.)	If the voltage is out of range of 94.0 \pm 0.5 Vac, adjust the voltage to 94.0 Vac by RV2 on the main PCB. After adjustment, tube current confirmation should be done. (Refer to page 16.)
E.06	Tube current of the last pulse is more than 12.5 mA.	AVR voltage is too high.	Measure the voltage between TP2 on the main PCB and terminal #3 of the terminal block in the control box, when the exposure switch is pressed in the "Adj" mode. (Press P-T2-T3 and power switch for "Adj" mode.)	If the voltage is out of range of 94.0 \pm 0.5 Vac, adjust the voltage to 94.0 Vac by RV2 on the main PCB. After adjustment, tube current confirmation should be done. (Refer to page 16.)
E.07	Tube current during exposure is less than 5 mA.	a. AVR voltage is too low.	Measure the voltage between TP2 on the main PCB and terminal #3 of the terminal block in the control box, when the exposure switch is pressed in the "Adj" mode. (Press P-T2-T3 and power switch for "Adj" mode.)	If the voltage is out of range of 94.0 \pm 0.5 Vac, adjust the voltage to 94.0 Vac by RV2 on the main PCB. After adjustment, tube current confirmation should be done. (Refer to page 16.)
		b. Cables between the control box and head are broken or mis-wired.	Check each cables for continuity and mis-wiring.	Correct the cable. (Refer to page 25.)
		c. Main PCB (075P-PW00) is defective.	If all cables are OK and AVR voltage cannot be adjusted to 94.0 Vac in the "Adj" mode, main PCB may be defective.	Change the main PCB and check AVR again.
		d. Defect of tube head. (Filament damage.)	If AVR voltage and cable are all right, tube head may be defective.	Change the tube head and confirm the function again.

CODE	MEANING	POSSIBLE CAUSE	CHECK POINT	SOLUTION
E.08	Tube current during exposure is more than 15 mA.	<p>a. AVR voltage is too high.</p> <p>b. Cables between the control box and head are broken or mis-wired.</p> <p>c. Power generating PCB is defective.</p> <p>d. Defect of tube head. (Internal short)</p>	<p>Measure the voltage between TP2 on the main PCB and terminal #3 of the terminal block in the control box, when the exposure switch is pressed in the "Adj" mode. (Press P-T2-T3 and power switch for "Adj" mode.)</p> <p>Check each cables for continuity and mis-wiring.</p> <p>If all cables are OK and AVR voltage cannot be adjusted to 94.0 Vac in the "Adj" mode, main PCB may be defective.</p> <p>If AVR voltage and cable are all right, then tube head may be defective.</p> <p>Check the L.OO value and H.OO values. (Refer to page 11.)</p>	<p>If the voltage is out of range of 94.0 \pm0.5 Vac, adjust the voltage to 94.0 Vac by RV2 on the main PCB. After adjustment, tube current confirmation should be done. (Refer to page 16.)</p> <p>Correct the cable. (Refer to page 25.)</p> <p>Change the main PCB and check AVR again.</p> <p>Change the tube head and confirm the function again.</p> <p>If L.OO is higher than H.OO, send the control box to Belmont for adjustment.</p>
E.09	Malfunction of the micro-computer.	Memory setting for lower limit of line voltage is higher than the higher limit of line voltage.		

SECTION 8: TROUBLE SHOOTING

Error code is displayed in the exposure time display window for most troubles in daily usage. So the error code table in section 6 can be used as trouble shooting chart in most case. Some troubles that don't make error code displayed are listed in the following table with their possible causes, check points and solutions.

PROBLEM	POSSIBLE CAUSE	CHECK POINT	SOLUTION
1. "FIN" doesn't appear in the auto mode for tube current confirmation. (page 17)	AVR voltage is too high or too low.	Measure the voltage between TP2 on the main PCB and terminal #3 of the terminal block in the control box, when the exposure switch is pressed in the "Adj" mode. (Press P-T2-T3 and power switch for "Adj" mode.)	If the voltage is out of range of 94.0 \pm 0.5 Vac, adjust the voltage to 94.0 Vac by RV2 on the main PCB. After adjustment, tube current confirmation should be done. (Refer to page 16.) If the voltage is within the range, set final PH.O and EP.O values manually. (Press P-C-F and power switch for manual setting mode. Refer to page 19.) Correct the cable.
2. AVR voltage cannot be adjusted to 94.0 Vac in the "Adj" mode.	a. Cables between the control box and head are broken or mis-wired. b. Power generating PCB or timer PCB is defective.	If AVR voltage is staying around line voltage, cables may be broken. (especially #3 and #5 cables) If cables are OK, either PCB may be defective.	Change the power PCB first and if AVR voltage still cannot be adjusted, change timer PCB. Change the exposure switch.
3. Exposure does not start when exposure switch is depressed.	a. Exposure switch is defective. b. Exposure time setting is "0.00".	Disconnect CN4 from power generating PCB and short the terminal #1 and #2 of CN4 instead of pressing the exposure switch. If exposure can be made, exposures witch is defective. Check the exposure time display window.	Change the exposure switch.
4. Radiograph is too dark or too light.	a. Exposure time is too long or too short. b. Processing condition is not adequate. c. Tube current is too high or too low.	Check the tooth, patient, cone and film type are adequate. Check the solution, temperature or processing speed, etc. Check the tube current. (Refer to page 17).	Press a tooth switch or manual setting switch for exposure time. Proper tooth, patient and cone type should be selected. If film type is different, set adequate film speed. Correct the processing condition. If tube current is out of 10 \pm 0.5mA, adjust PH and EP value.

SECTION 9: REPLACEMENT OF COMPONENT

[1] CONTROL BOX

(1) POWER GENERATING PCB

1. If one or more results of verification checks on page 23 are out of specification or trouble shooting chart indicates, power generating PCB should be replaced.
2. Since Q7~9 and Q13 are power MOS FETs, great care should be paid against electrostatic discharge (ESD).
 - a. Personnel who handle PCB should touch the grounding screw (green/yellow wire) in the control box and discharge the static electricity from his body before working.
 - b. Replaced PCB should be stored in the anti-static bag.
3. As connector CN1~3 have latches, unlock these latches when disconnecting. When disconnecting, do not pull the wires but pull the housing of connector. As the latches for CN3 have the releasing mechanism, opening the latches on both side of CN3 makes connector disconnected automatically.
4. As CN1 and CN2 are the same type of connectors, be careful not to connect reversely. Wires from main switch go to CN1 and wires from terminal #3~#5 go to CN2.

(2) TIMER PCB

1. If one or more results of verification checks on page 24 are out of specification or trouble shooting chart indicates, timer PCB should be replaced.
2. Since micro computer on the timer PCB is C-MOS type, same care as power generating PCB should be paid against ESD.
3. 6 screws for shield plate and 5 screws for timer PCB are used. Since these screws are used against plastic panel, don't over tighten when installing a new PCB.
4. After new timer PCB is installed, following confirmation, adjustment and setting must be performed. If the setting of b.~d. below is not changed from factory setting for the previous timer PCB, only a. is necessary. (a is always necessary.)
 - a. Tube current confirmation and adjustment.
 - b. Film speed setting.
 - c. Priority setting for patient, cone and film speed.
 - d. Electronic chime on/off setting

(3) EXPOSURE SWITCH

1. Since the connector housing cannot go through the hole at the bottom of control box, take pins from the housing by a jeweller's screw driver.
2. When putting pins back to the housing, be careful to the direction of pins as the stopper comes to the right position.
3. After new exposure switch is installed, pull the cable and confirm no stress goes to CN4.

[2] TUBE HEAD

1. If one or more results of verification checks on page 24 are out of specification or trouble shooting chart indicates, tube head should be replaced.
2. When dismantling the head from arm, be careful of the arm.

▲ WARNING: AS BALANCE ARM IS HIGHLY TENSIONED, IT IS NECESSARY TO PLACE THE HEAD AT MAXIMUM HEIGHT BEFORE REMOVING HEAD.
3. After new head is mounted, adjustment of tube current is always necessary. Perform PH and EP adjustment according to the steps described at auto mode on page 17.

SECTION 10 : CIRCUIT DIAGRAM

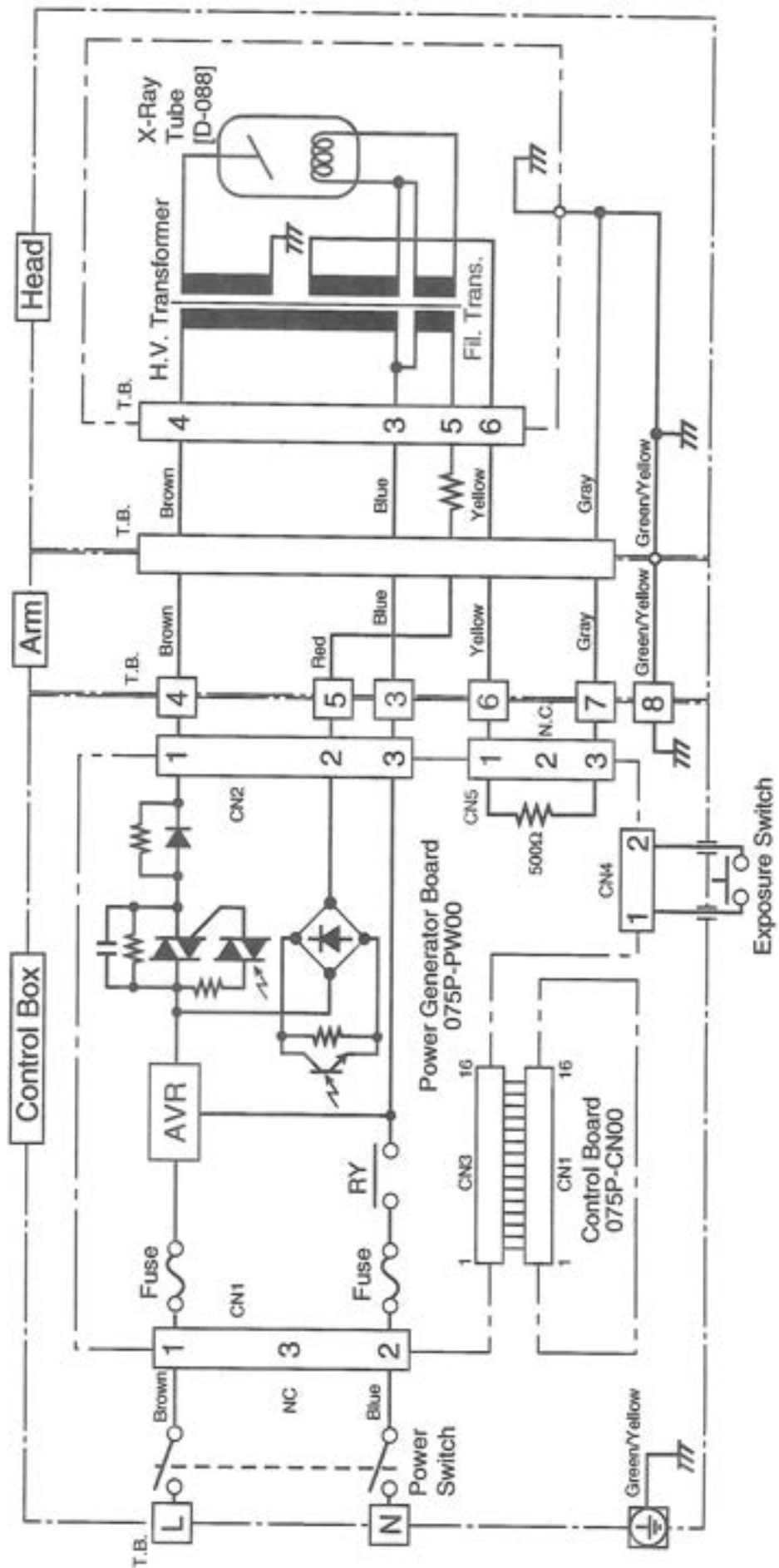

Ind.	Parts No.	Description	Belmont No.
36	EHL05A0	Arm Mounting Bracket Ass'y	096-1350
37	-----	Machine Bolt (M8-20)	096-1360
38	ECPR53A0	Bolt Cap	096-1370
39	ECPR44A0	Retaining Bolt	096-1380
40	EHL15A0	Arm Mounting Bracket Ass'y	096-1390
41	ECPR45B0	Bottom Cover	096-1400
42	-----	Bottom Cover Screw (M3-6)	096-1410
43	ECPR52A0	Plate Bolt Cap	096-1420
44	-----	Plate Bolt (Ø9-75)	096-1430
45	ECPJ19A0	Wall Mount Plate	096-1620
46	ECPJ18A0	Wall Mount Plate for Cover Type	096-1621
47	EHL11A0	Wire Harness in Balance Arm	096-1081
48	ECNR18A0	Yoke Side Cap	096-1630
49	ECPJ15B0	Yoke Inside Cover (RAL-9002)	096-1021
50	ECLJ82A0	Adjust Wrench	096-1082
51	EHL14A0	Cover Set for Wall Mount Plate	096-1625
52	EHL07A0	Control Box Assembly (for 120V)	096-1000
53	EHL08A0	Control Box Assembly (for 220V)	096-1001
54	EHL09A0	Control Box Assembly (for 230V)	096-1002
55	EHL10A0	Control Box Assembly (for 240V)	096-1003
56	ECPE01A0	Chassis	096-1440
57	-----	Fuse (F1/F2 - 10A)	096-1450
58	-----	Terminal Block (4P)	096-1460
59	-----	Power Switch	096-1470
60	ECPJ07B0	Covering Plate	096-1480
61	-----	Timer Board	096-1490
62	ECPB01E0	Front Cover	096-1500
63	-----	Top Screw (M3-8)	096-1510
64	-----	Fuse (F3 - 0.5A)	096-1520
65	-----	Wood Screw for Chassis (Ø5.8-32)	096-1530
66	-----	Fuse (F4 - 1A)	096-1540
67	-----	Terminal Block (5P)	096-1550
68	ECNJ09A0	Hook for Hand Exposure Switch	096-1560
69	EHL06A0	Hand Exposure Switch Ass'y	096-1570
70	-----	Screw for Hook (Ø3-12)	096-1580
71	-----	Restriction Plate	096-1590
72	ECPR20A0	Power Board for 120V	096-1600
73	-----	Power Board for 220 ~ 240V	096-1601
74	-----	Front Sheet	096-1610

Ind.	Parts No.	Description	Belmont No.
1	EHL03A0	X-Ray Head Assembly	096-1010
2	ECPE03D0	Yoke	096-1020
3	EHL12A0	Housing Cover Set	096-1030
4	ECPR22B0	Lock Ring	096-1040
5	ECPR36A0	X-Ray Exposure Sleeve	096-1050
6	ECPR21B0	Regular Cone	096-1060
7	EHL13A0	Long Cone (Option)	096-1070
8	EHL04A0	Balance Arm Assembly	096-1080
9	ECLS01A0	Stopper Ring	096-1090
10	ECPR54A0	Make-up Seal No.1	096-1100
11	-----	Collar Screw (SUS M4-8)	096-1110
12	ECLS22A0	Collar	096-1120
13	-----	Stopper Screw (M4-8)	096-1130
14	ECPE07A0	Joint No.3	096-1140
15	ECLJ25A0	Spring Adjuster Cover	096-1150
16	ECLJ39A0	Balance Arm No.2	096-1160
17	ECPJ21A0	Arm Cover	096-1170
18	ECPR55A0	Make-up seal No.2	096-1180
19	ECLS29A0	Set Pin	096-1190
20	ECLS04A0	Link Pin	096-1200
21	ECPE08A0	Joint No.2	096-1210
22	ECLJ36A0	Balance Arm No.1	096-1220
23	ECLR80A0	Cushion Absorber	096-1230
24	ECLS68A0	Arm Pin	096-1240
25	ECLS28A0	Cover Pin	096-1250
26	ECPE06A0	Joint No.1	096-1260
27	ECLR95A0	Head Key	096-1270
28	EHLK90A0	Horizontal Arm Ass'y (800mm)	096-1280
	EHLK87A0	Horizontal Arm Ass'y (300mm)	096-1281
	EHLK88A0	Horizontal Arm Ass'y (500mm)	096-1282
	EHLK89A0	Horizontal Arm Ass'y (650mm)	096-1283
	EHLK91A0	Horizontal Arm Ass'y (1000mm)	096-1284
29	-----	Horizontal Arm	096-1290
30	ECLS06A0	Brake Plug	096-1300
31	-----	Brake Screw (M6-6)	096-1310
32	ECLS09A0	Stopper Screw	096-1320
33	ECLJ36A0	End Cap	096-1330
34	-----	End Cap Screw (M6-15)	096-1340
35	ECNR24A0	Hole Plug for End Cap	096-1341



BELMONT EQUIPMENT CORP.

101 Belmont Drive Somerset, New Jersey 08873 U.S.A. TEL.:(732) 469-5000 / (800) 223-1192 Fax. Toll Free:(800) 280-7504

TAKARA CO, CANADA LTD.

2076 S. Sheridan Way, Mississauga, Ont., L5J2M4, Can. TEL.:(905) 822-2755 Fax.:(905) 822-6203

Book No. EDAW1

Printed in Japan 0109 MA