

Bel-Halo  
INSTALLATION INSTRUCTIONS

# Table of Contents

Precautions for installation .....4



## **5 POST MOUNT** (AL-D241G / AL-D241W)

Necessary tools and supplied parts ..... 6

Assembly procedure for installation ..... 7



## **8 CEILING MOUNT** (AL-D242G)

Necessary tools and supplied parts ..... 9

Assembly procedure for installation ..... 10



## **13 TRACK MOUNT** (AL-D245G)

Necessary tools and supplied parts ..... 14

Assembly procedure for installation ..... 15

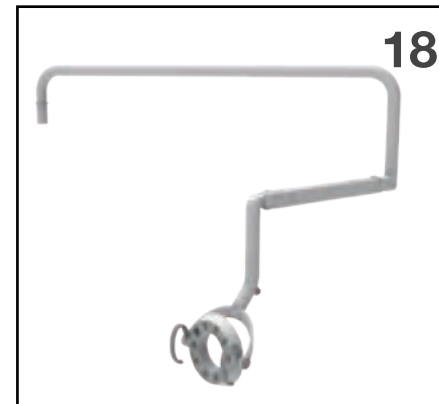

## **18 CABINET MOUNT** (AL-D247G)

Necessary tools and supplied parts ..... 19

Assembly procedure for installation ..... 20

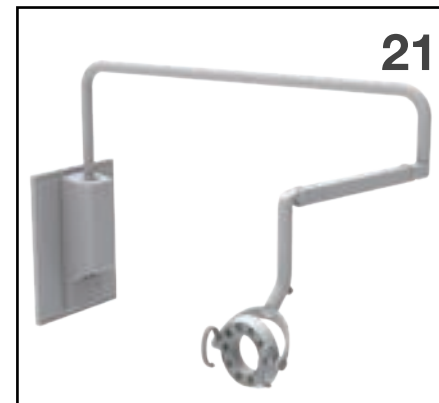

## **21 WALL MOUNT** (AL-D248G)

Necessary tools and supplied parts ..... 22

Assembly procedure for installation ..... 23

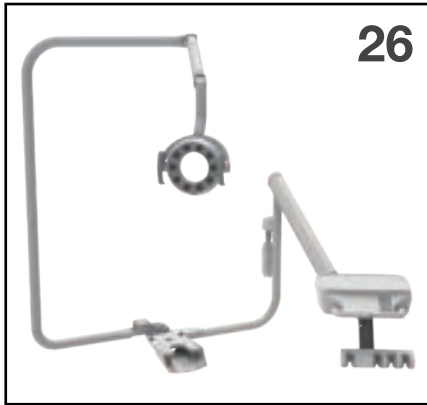

**26**

**QUOLIS UNIT MOUNT**

(AL-D246G-QU)

Necessary tools and supplied parts .... 27  
 Assembly procedure for installation .... 28



**31**

**EVOGUE UNIT MOUNT**

(AL-D246G-EV)

[Cuspidor Mount]  
 Necessary tools and supplied parts .... 32  
 Assembly procedure for installation .... 33

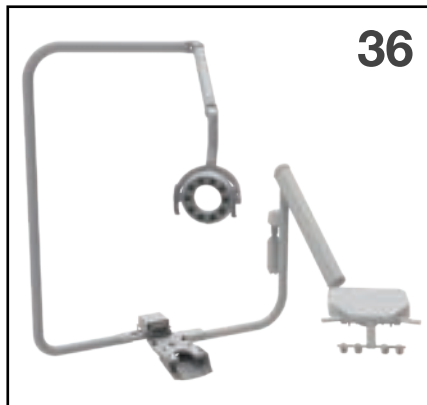

**36**

[Swing Arm Mount]

Necessary tools and supplied parts .... 37  
 Assembly procedure for installation .... 38

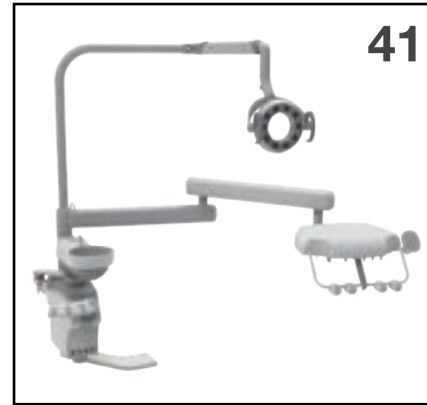

**41**

**X-CALIBUR UNIT MOUNT**

(AL-D249W-XN)

[Cuspidor Mount]  
 Necessary tools and supplied parts ..... 42  
 Assembly procedure for installation ..... 43

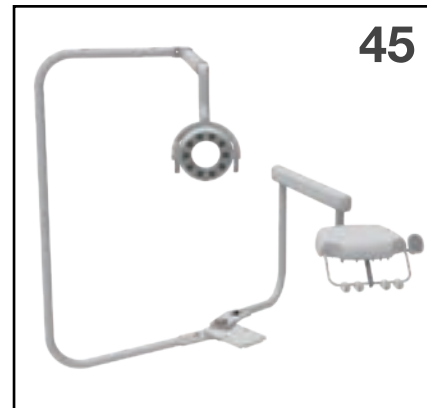

**45**

(AL-D249W-X)

[Swing Arm Mount]  
 Necessary tools and supplied parts ..... 46  
 Assembly procedure for installation ..... 47

Adjusting the parts .....49

Attaching the patient mirror .....51

Wiring Diagram .....52

## Precautions for installation

1. During lifting of the dental light, make sure to hold the place shown in the figure below. If not, it may lead to physical injury or property damage. Do not lift the dental light by the handle. It may cause property damage.

AL-D241G / AL-D241W



AL-D242G



AL-D245G / AL-D247G / AL-D248G



AL-D246G / AL-D249W



2. Do not drop the product, let it crash into something, or apply strong impact.
3. Do not connect an input power supply other than with the rated power level.
4. Make sure to connect ground wires.
5. Have the clinic equipped with double-pole switch at the power outlet or the switchboard.
6. Adjust the levels of the unit and chair so that the light stops in the required position.  
Read the installation instructions for the unit and chair concerning the level adjustment. ( AL-D246G / AL-D249W )
7. Once all work is completed, confirm that each part operates normally.

### WARNING

To avoid the risk of electric shock, this equipment must only be connected to a supply mains with protective earth.  
Failure or electric leak may result in electric shock.

Do not directly expose human eyes to LED light.  
Exposure may hurt human eyes.

# POST MOUNT

(AL-D241G / AL-D241W)







## POST MOUNT [ Necessary tools and supplied parts ]

(AL-D241G / AL-D241W)

### Necessary tools

No.	Tool name	QTY.
1	Phillips screwdriver No. 1, 2	1 for each
2	Hex key wrench; width across flats: 2 mm / 2.5mm / 4mm	1 for each

### Supplied parts

No.	Part name		QTY.
1	Light head		1
2	Pole adapter		1
3	Button head bolt		4
4	Adjustment rod		1

# POST MOUNT [ Assembly procedure for installation ]

(AL-D241G / AL-D241W)

## STEP1 : Attach the light arm to the Light pole.

- ① Pass the power cable through the pole adapter and fix it to the light arm.
- ② Pass the power cable through the light pole.
- ③ Attach the light arm to the light pole.  
(4 button bolts)

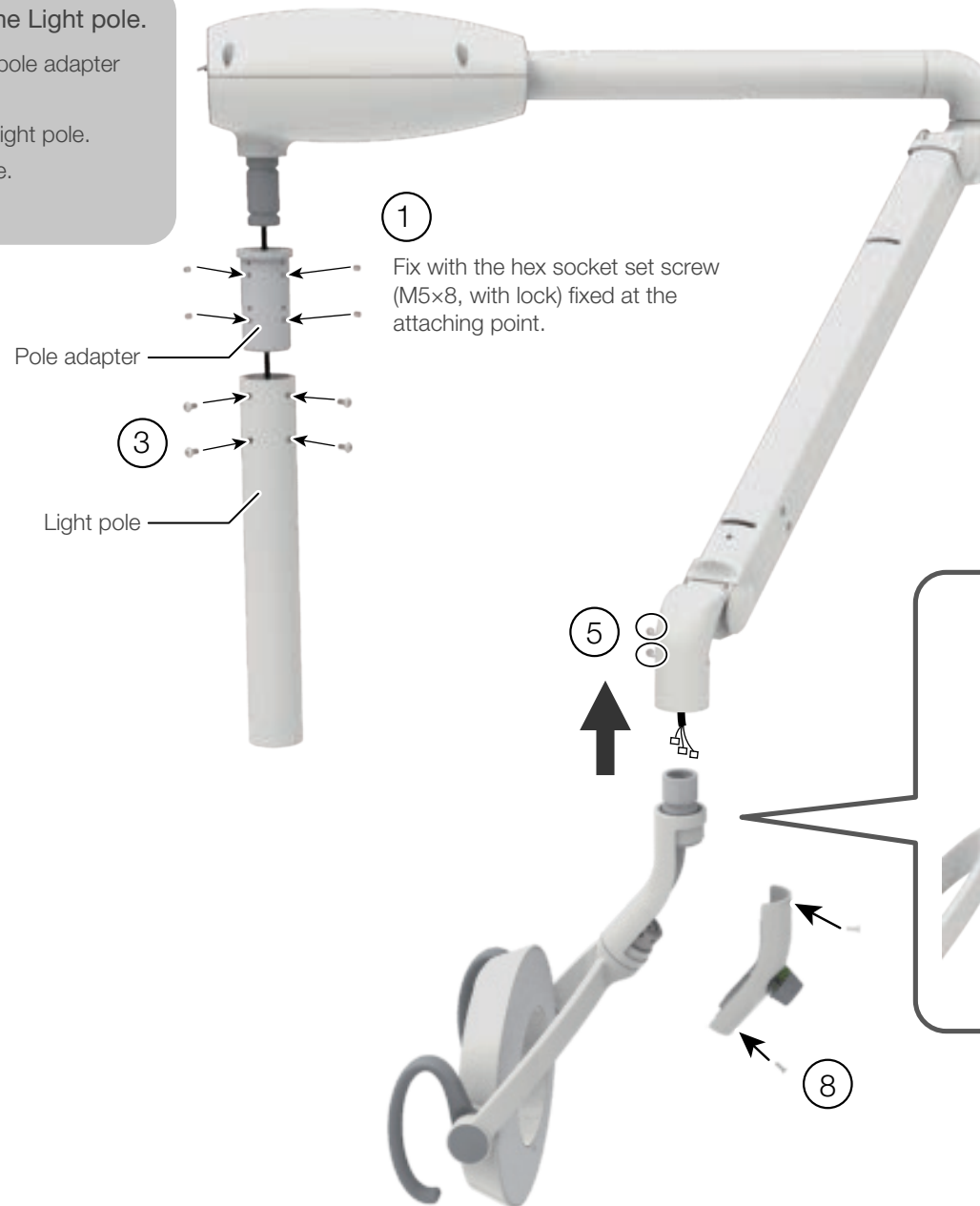

## STEP2 : Attach the light head.

- ④ Remove the yoke cover from the light head. (2 countersunk screws)
- ⑤ Pass the lead wire in the arm through the light head and attach the light head to the arm. (2 pan head screws fixed at the attaching point.)
- ⑥ Connect the connectors from the arm to the light head connectors. (2 pcs.)
- ⑦ Connect the connector from the arm to the LED control PCB behind the yoke cover. (1 pc.)
- ⑧ Re-attach the yoke cover.

## STEP3 : Plug the power cable into the outlet.

Rated voltage AC100-240V  
Rated input 0.30-0.15A

# CEILING MOUNT

(AL-D242G)





# CEILING MOUNT [ Necessary tools and supplied parts ]

(AL-D242G)

## Necessary tools

No.	Tool name	QTY.
1	Phillips screwdriver No. 1, 2	1 for each
2	Hex key wrench; width across flats: 2 mm / 2.5mm / 4mm	1 for each
3	Hammer	1
4	Socket wrench (13mm, 17mm)	1 for each

## Supplied parts

No.	Part name	QTY.
1	Ceiling flange set	1
2	<u>Ceiling material : Wood</u> Flat washer M10, plated Spring washer M10, plated Ccoach bolt M9 x 100, plated	 4 for each
	<u>Ceiling material : Steel Frame / Concrete</u> Flat washer M8, plated Spring washer M8, plated Hex bolt M8 x 50, plated	 4 for each

No.	Part name	QTY.
3	Roll pin	1
4	Extension post	1
5	Hex socket set screw M6 x 8, SUS (with red mec thread lock)	4
6	Flange cover	1
7	Flange cover ring	1
8	Hex socket set screw M6 x 8, plated (with red mec thread lock)	3
9	Light head	1
10	Adjustment rod	1

# CEILING MOUNT [ Assembly procedure for installation ]

(AL-D242G)

## STEP1 : Attach the flange base to the ceiling.

- ① Lead out the power supply cable from the ceiling.
- ② Remove the nuts and washers from the included ceiling flange set shown in the figure and remove the ceiling flange.

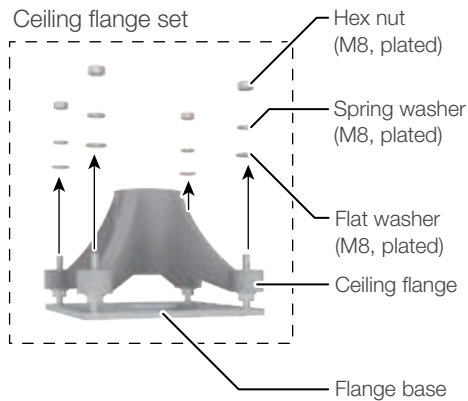

- ③ Pass the power supply cable pulled out in ① through the hole in the flange base, and fix the flange base to the ceiling. Refer to "Flange base template" [page12] for the flange base fixing hole dimensions.

Ceiling material	Wood	Steel Frame	Concrete
Prepared hole diameter	$\phi 3/16"$ (5mm)	$\phi 3/8"$ (10mm)	M8 Embedded Anchor nut
Fixing bolt	Coach bolt M9 x 100, plated	Hex bolt M8 x 50, plated	Hex bolt M8 x 50, plated

## STEP2 : Set the extension post on the ceiling flange.

- ④ Attach the roll pin to the extension post with hammer.
- ⑤ Insert the extension post into the ceiling flange and set the roll pin to groove on the ceiling flange.
- ⑥ Fix it with hex socket set screws (4 pieces)

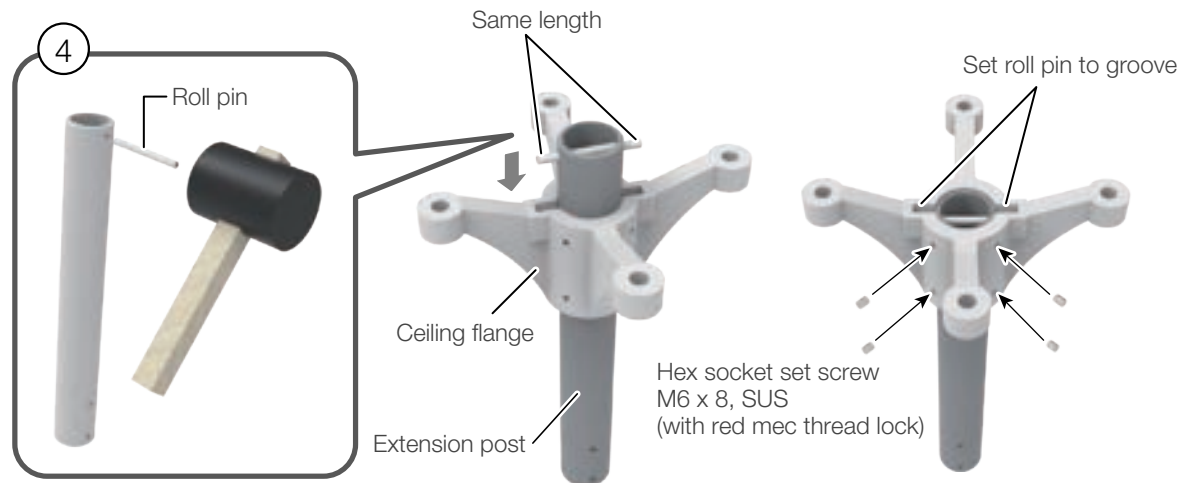

# CEILING MOUNT [ Assembly procedure for installation ]

(AL-D242G)

## STEP3 : Attach the arm to the pole.

- ① Fix the ceiling flange to the flange base.
- ② Slide the flange cover and flange cover ring (flat side up) over the extension post and temporary fix them about half way up the pole.  
Use only one hex socket set screw (M6 x 8, plated) (With red mec thread lock) as you will be moving the on final installation.
- ③ Pass the lead cable from the arm through the extension post, and pull it out from the position shown in the figure.
- ④ Attach the arm to the extension post.  
Determine the rotation limit and fix with the 4 hex socket set screws (M5 x 10, plated) fixed on the attaching point.
- ⑤ Connect the power supply cable in① and the lead cable in③ with the one-touch connector.  
Return any excess wirings to the ceiling.
- ⑥ Reposition the flange cover and secure it with the flange cover ring.  
Secure three hex socket set screws M6 x 8, plated.

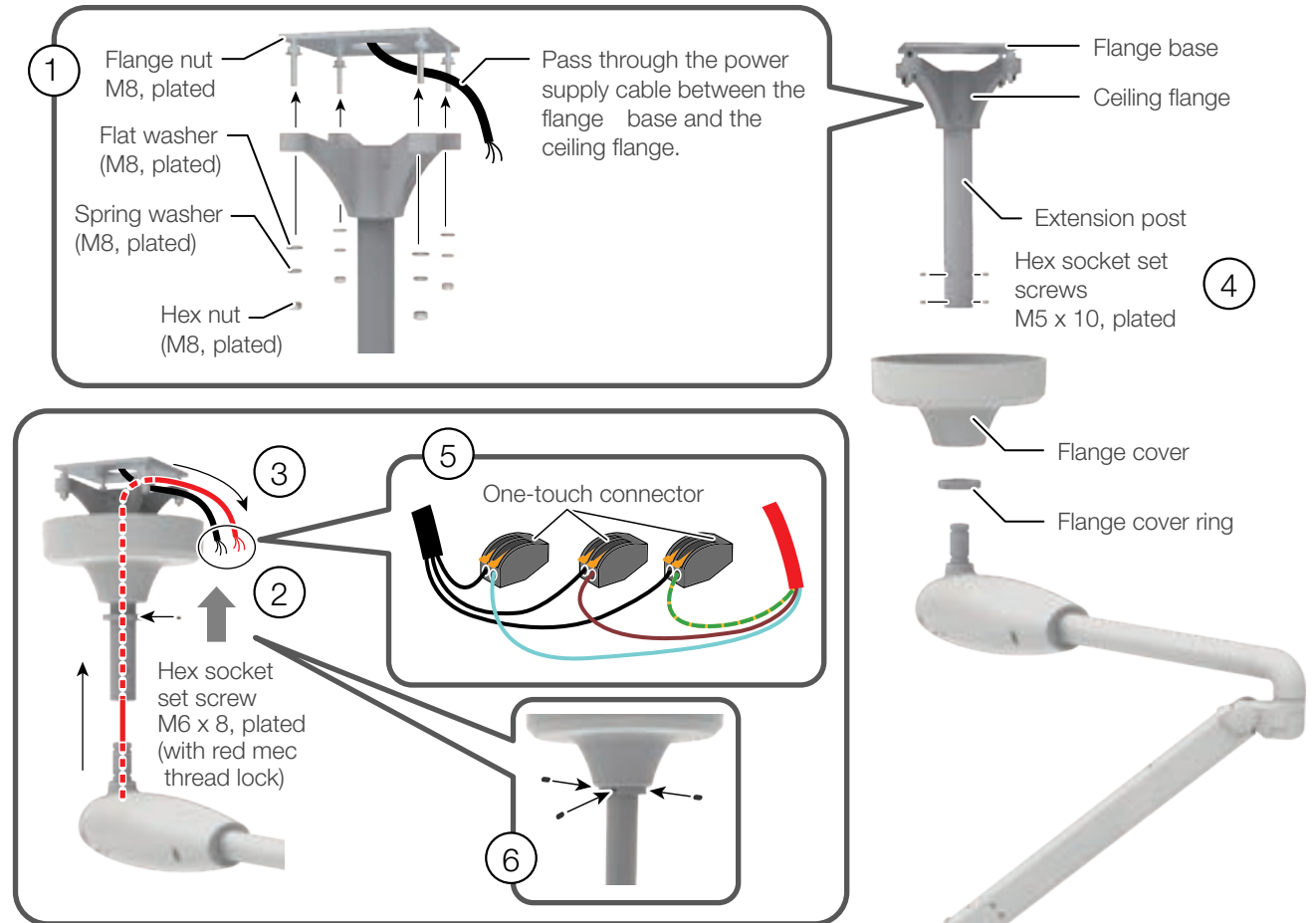

## STEP4 : Attach the light head.

- ⑦ Remove the yoke cover from the light head. (2 countersunk screws)
- ⑧ Pass the lead wire in the arm through the light head and attach the light head to the arm. (2 pan head screws fixed at the attaching point.)
- ⑨ Connect the connectors in the arm to the light head connectors. (2 pcs.)
- ⑩ Connect the connector from the arm to the LED control PCB behind the yoke cover. (1 pc.)
- ⑪ Re-attach the yoke cover.

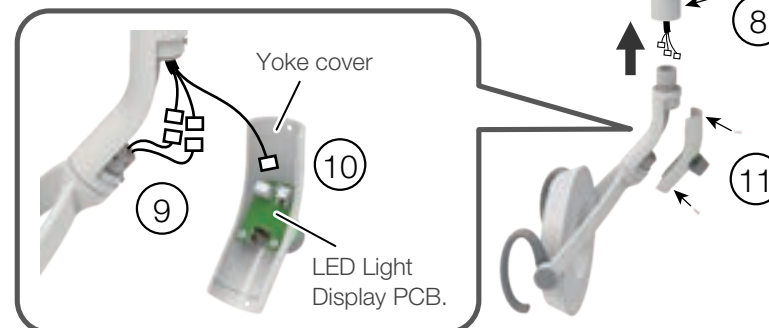

# CEILING MOUNT [ Assembly procedure for installation ]

(AL-D242G)

Flange base template

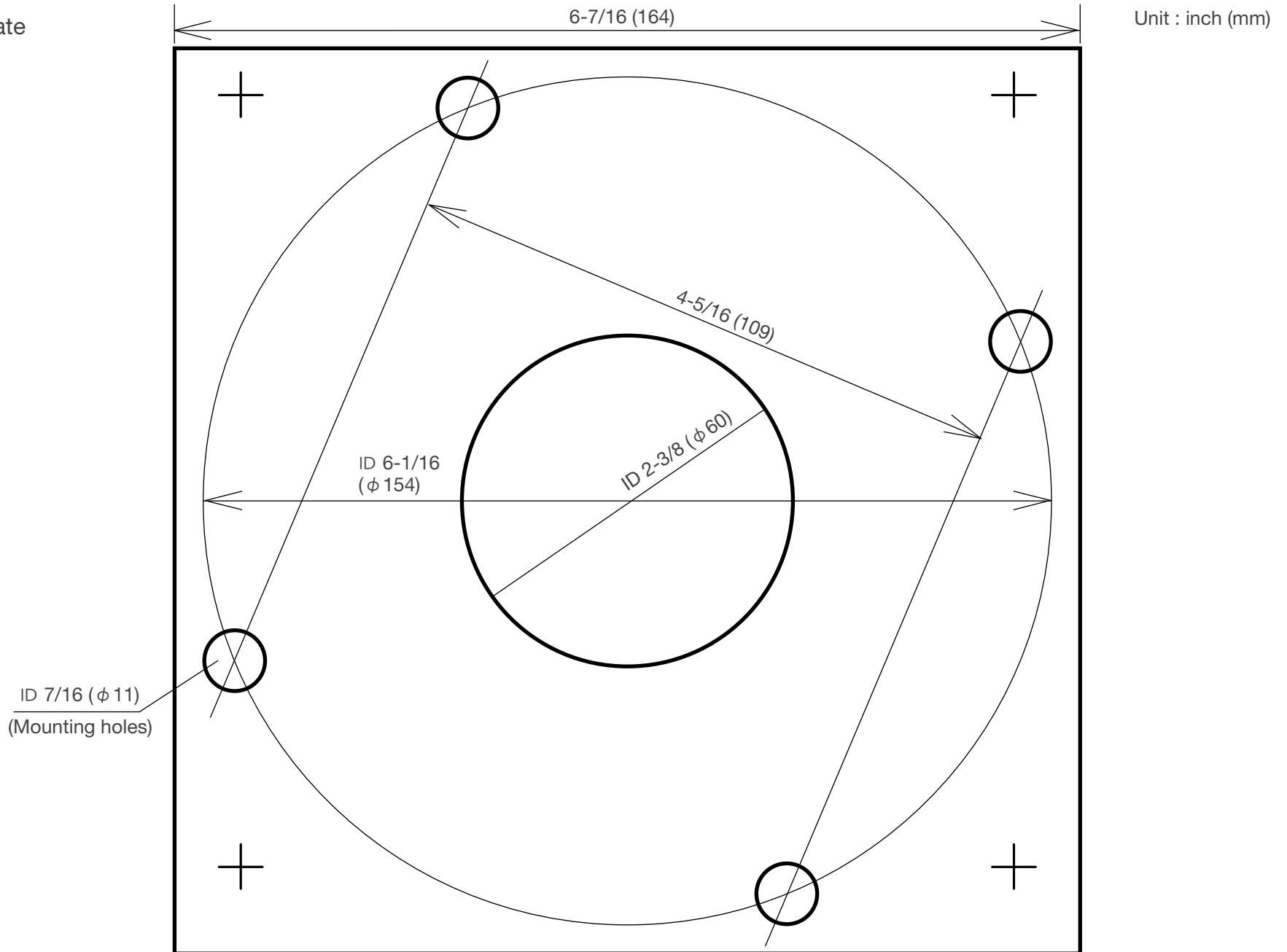

# TRACK MOUNT

(AL-D245G)



# TRACK MOUNT [ Necessary tools and supplied parts ]

(AL-D245G)

## Necessary tools

No.	Tool name	QTY.
1	Phillips screwdriver No. 1, 2	1 for each
2	Hex key wrench; width across flats: 2 mm / 2.5mm / 4mm	1 for each
3	Hammer	1
4	Socket wrench (13mm, 17mm)	1 for each

## Supplied parts

No.	Part name	QTY.
1	Pallet	1
2	Coach bolt M8 x 75, plated	8
3	Track	1
4	Light head	1
5	Barance arm	1
6	Hex bolt M8 x 25, plated	6

No.	Part name	QTY.
7	Flat washer M8, plated	6
8	Power supply box	1
9	Pan head screw 4P, M4 x 15, plated	4
10	Trolley	1
11	Trolley collar	1
12	Extension post	1
13	Rubber bumper	4
14	Bind screw M4 x 10	4
15	End-cap	1
16	Bottom cover	1
17	Adjustment rod	1

# TRACK MOUNT [ Assembly procedure for installation ]

(AL-D245G)

## STEP1 : Drill a light pallet fixing holes in the ceiling.

Refer to the figure below for the positions of the power cable / light pallet fixing holes.

Refer to below figure for the location of electrical feed opening in pallet, provide 3 wire, circuit (fuse or breaker) through flexible conduit with enough slack to protrude at least 2" (50mm) below the pallet when installed.

A readily accessible shut-off switch for this circuit is recommended.

Use wiring suitable for 194°F (90°C) service.

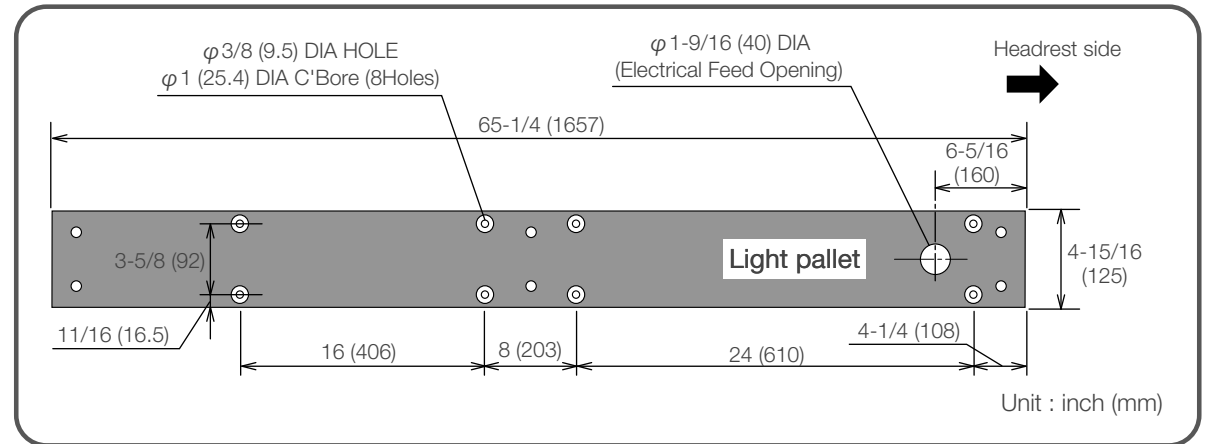

## STEP2 : Attach the light pallet to the ceiling.

Pull out the power cable from the ceiling and pass it through the light pallet.

### In conventional ceilings with joists perpendicular to the center line of the light

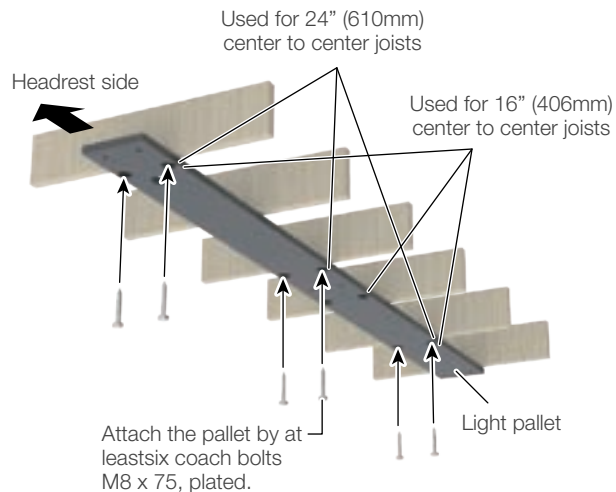

### In conventional ceilings with joists parallel to the center line of the light

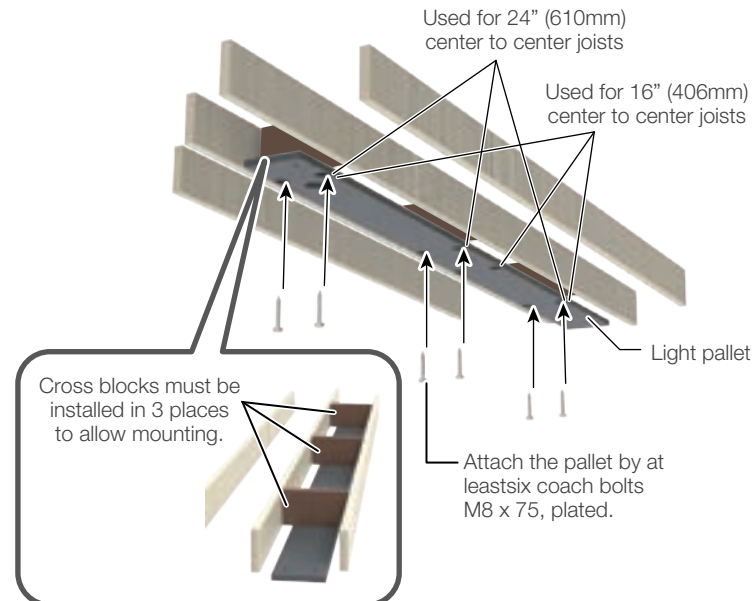

### In suspended ceilings

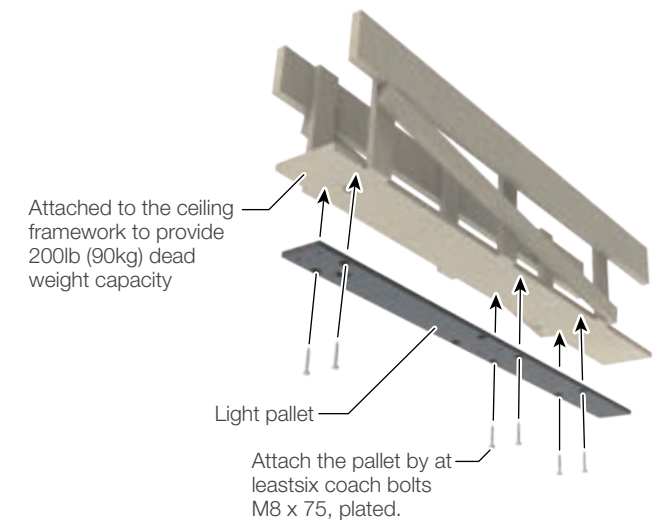

# TRACK MOUNT [ Assembly procedure for installation ]

(AL-D245G)

## STEP3 : Attach the track to the light pallet.

- ① Run the power supply cable from the ceiling through the electric feed opening of the track, and fix the opposite side of the electric feed opening on the truck to the pallet with two hex bolts and two flat washers.
- ② Pass the power cable from the ceiling through the electric opening of the track, and connect the power cable from the ceiling and the wire of the track with the one-touch connector. Return any excess wirings to the ceiling.
- ③ Fix the track with six hex bolts and six flat washers.

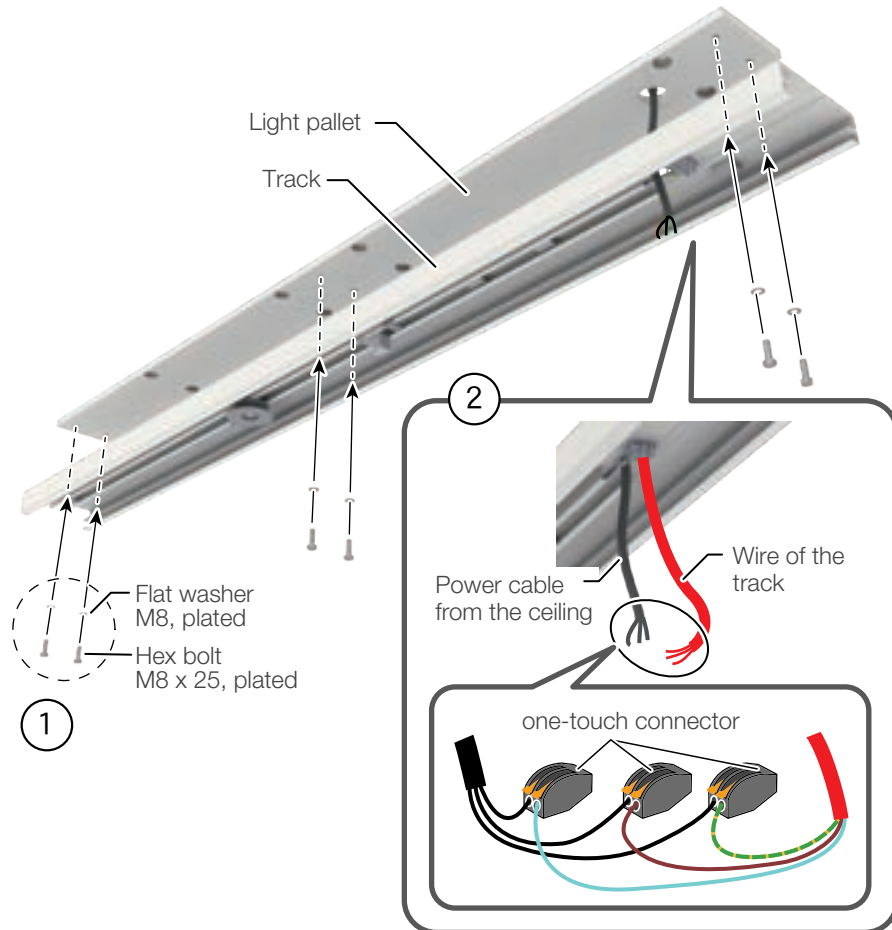

## STEP4 : Attach the balance arm to the trolley.

- ④ Attach the trolley collar and extension post to the trolley. (2 hex socket set screws fixed at the attaching point.)
- ⑤ Lead the electric wire coming from the track body through the extension post, then connect it with the connector coming from the lead wire in the balance arm.
- ⑥ Insert the extension post to balance arm. Determine the rotation limit and fix with the 4 set screws fixed on the attaching point.

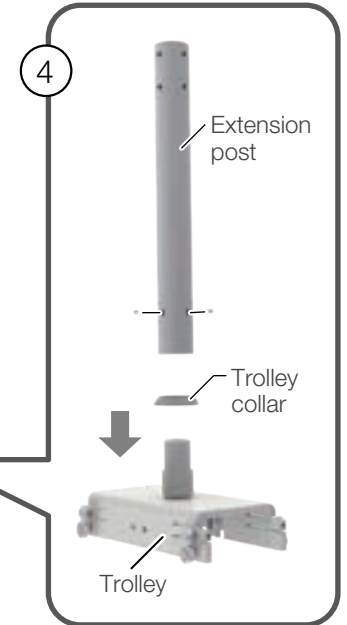

## STEP5 : Attach the light head.

- ⑦ Remove the yoke cover from the light head. (2 countersunk screws)
- ⑧ Pass the lead wire in the arm through the light head and attach the light head to the arm. (2 pan head screws fixed at the attaching point.)
- ⑨ Connect the connectors from the arm to the light head connectors. (2 pcs.)
- ⑩ Connect the connector from the arm to the LED control PCB behind the yoke cover. (1 pc.)
- ⑪ Re-attach the yoke cover.

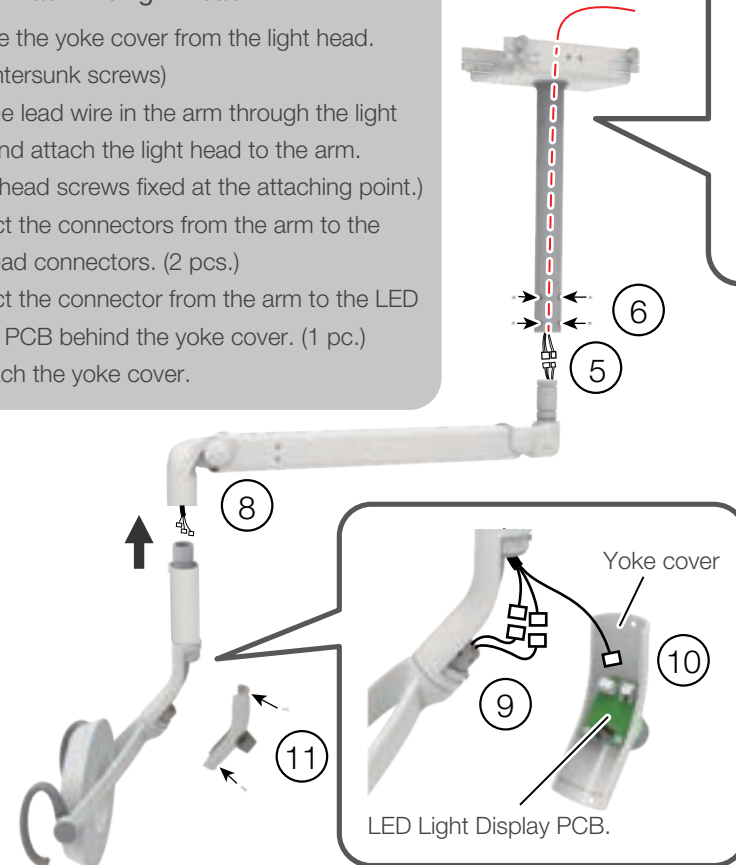

# TRACK MOUNT [ Assembly procedure for installation ]

(AL-D245G)

## STEP6 : Attach the light to the track

- ① Slide the light trolley on the track
- ② Carefully guide the wire from the trolley, around the spring-loaded pulley and back toward the end of track.
- ③ Secure the wire of ② to the track with the plastic wire clips (2 pcs.) and connect the connectors.
- ④ Install rubber bumpers (4 pieces) at the end of the track in the holes provided. (4 bind screws)

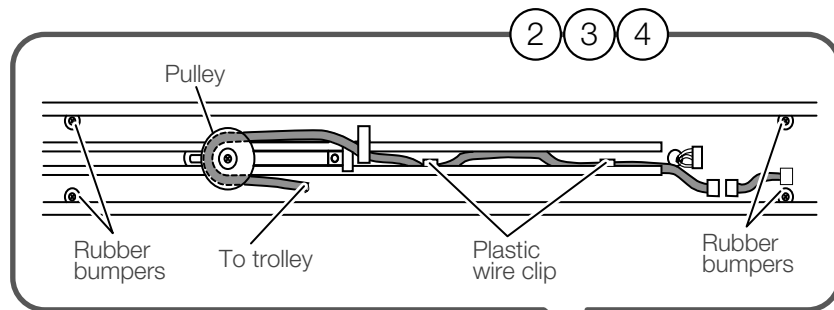

## STEP7 : Attach the power supply box and bottom cover

- ⑤ Attach the power supply box with the pan head screws (2 pieces).
- ⑥ Attach the power cable from the power supply box to the terminalblock.
- ⑦ Connect the connector from the power supply box to the connector from the track.
- ⑧ Attach the bottom cover by sliding from the edge of the track.
- ⑨ Attach the end-cap with the pan head screws (2 pieces).

Power supply box

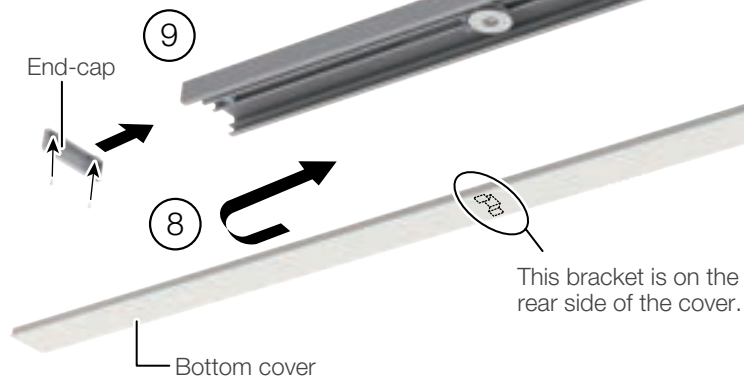
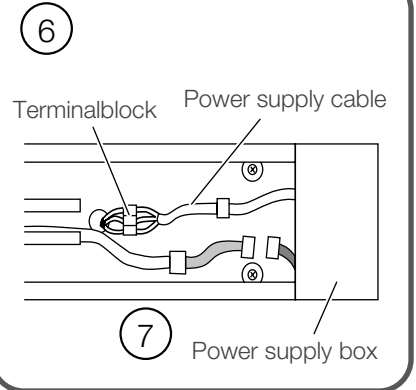

## Check operation of the trolley.

It is factory adjusted to provide smooth effortless travel, without play, however rollers can be readjusted if necessary.

Loosen the set screw and adjust the socket cap screw to vary roller clearance.

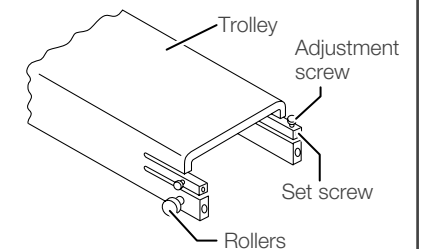

# CABINET MOUNT

(AL-D247G)









## CABINET MOUNT [ Necessary tools and supplied parts ]

(AL-D247G)

### Necessary tools

No.	Tool name	QTY.
1	Phillips screwdriver No. 1, 2	1 for each
2	Hex key wrench; width across flats: 2 mm / 2.5mm / 4mm	1 for each

### Supplied parts

No.	Part name	QTY.
1	Light pole 	1
2	Connection cable 	1
3	Light head 	1
4	Balance arm 	1
5	P.C.Board unit 	1
6	Adjustment rod 	1

# CABINET MOUNT [ Assembly procedure for installation ]

(AL-D247G)

## STEP1 : Attach the light pole.

- ① Insert the connection cable from the longer end of light pole through light pole receptacle.
- ② Pass the connection cable from the light pole through the pole receptacle and attach the light pole to the pole receptacle.

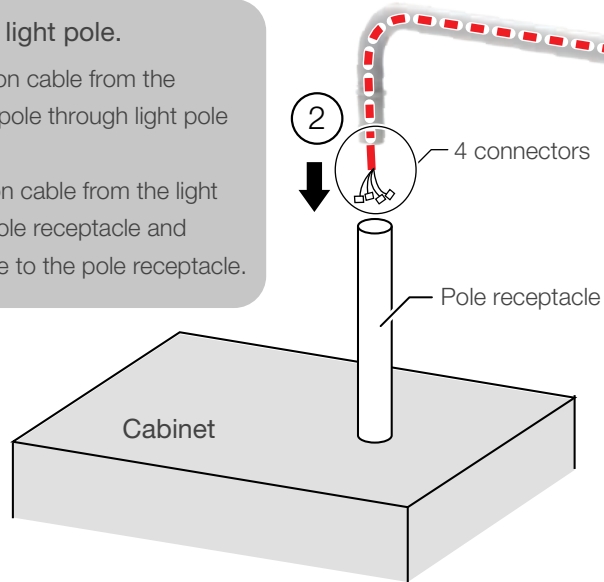

## STEP2 : Attach the balance arm to the light pole.

- ③ Connect the balance arm connector and the connection cable connector.
- ④ Insert the balance arm to the light pole.
- ⑤ Determine the range of the balance arm and fix the hex socket set screw fixed at the attaching point.

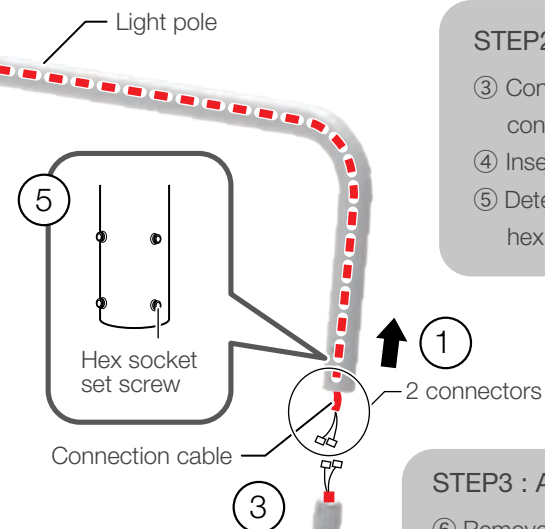

## STEP3 : Attach the light head.

- ⑥ Remove the yoke cover from the light head. (2 countersunk screws)
- ⑦ Pass the lead wire in the arm through the light head and attach the light head to the arm. (2 pan head screws fixed at the attaching point.)
- ⑧ Connect the connectors in the arm to the light head connectors. (2 pcs.)
- ⑨ Connect the connector from the arm to the LED control PCB behind the yoke cover. (1 pc.)
- ⑩ Re-attach the yoke cover.

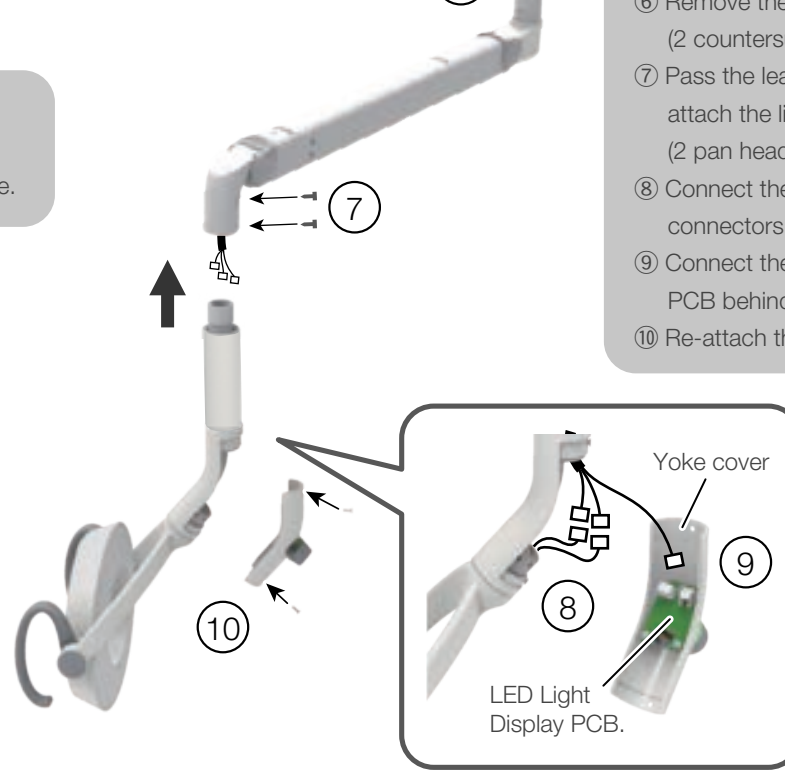

Refer to the cabinet installation manual to install the following accessories.

- Switch
- Fuse box
- Ground wire
- Noise filter
- Harness wire seals for cabinets

## STEP4 : Connect the wirings in the cabinet.

- ⑪ Attach the P.C.Board unit to the cabinet.
- ⑫ Connect the connectors of the connection cable as shown in the figure.

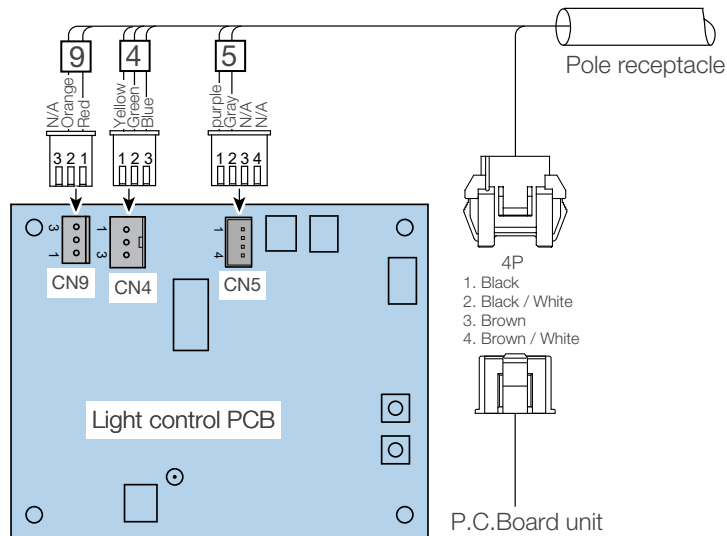

# WALL MOUNT

(AL-D248G)



## WALL MOUNT [ Necessary tools and supplied parts ]

(AL-D248G)

### Necessary tools

No.	Tool name	QTY.
1	Phillips screwdriver No. 1, 2	1 for each
2	Hex key wrench; width across flats: 2 mm / 2.5mm / 4mm	1 for each

### Supplied parts

No.	Part name	QTY.
1	Mount Wall Plate Assembly	1
2	Lag bolt M6	4
3	Washer	4
4	Light pole	1
5	Connection cable	1
6	Pole disc	1

No.	Part name	QTY.
7	Light head	1
8	Balance arm	1
9	Plate cover	1
10	Top cover	1
11	Tapping screws	4
12	Tapping screws with washers	2
13	Adjustment rod	1

# WALL MOUNT [ Assembly procedure for installation ]

(AL-D248G)

## Wall Plate pre-installation requirement

Unit: inch (mm)

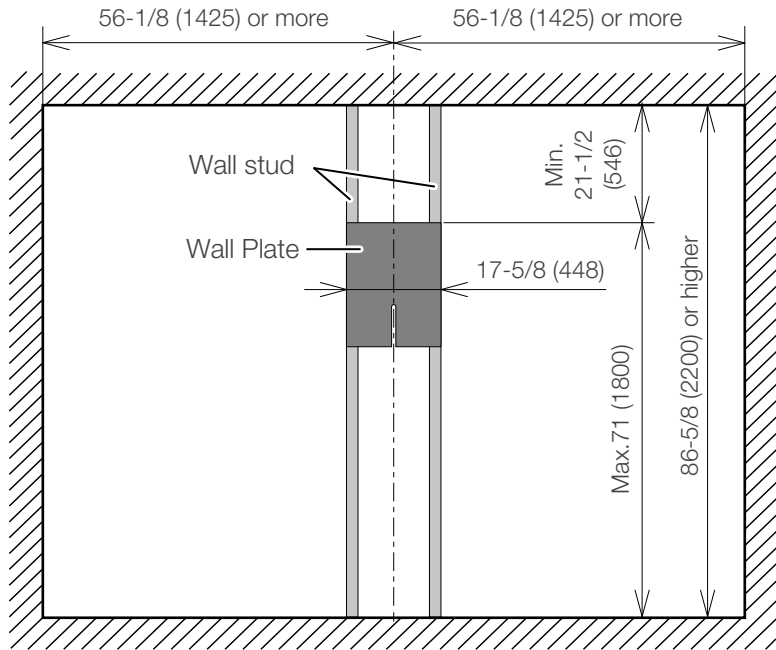

Unit: inch (mm)

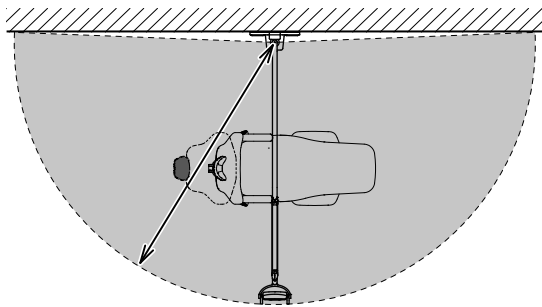

- Maximum reach of light head from center is 94-5/8 (2403)
- Position the chair and light so that when the chair backrest is recline, the light head can be brought to the patient's mouth area.

## STEP1 : Make a pilot hole in the wall

Drill four(4) pilot holes with 3/16" bit, depth of 2"

The wall plate must be securely mounted to the wall studs.

DO NOT mount to metal studs.

## Wall Plate dimensions

Unit: inch (mm)

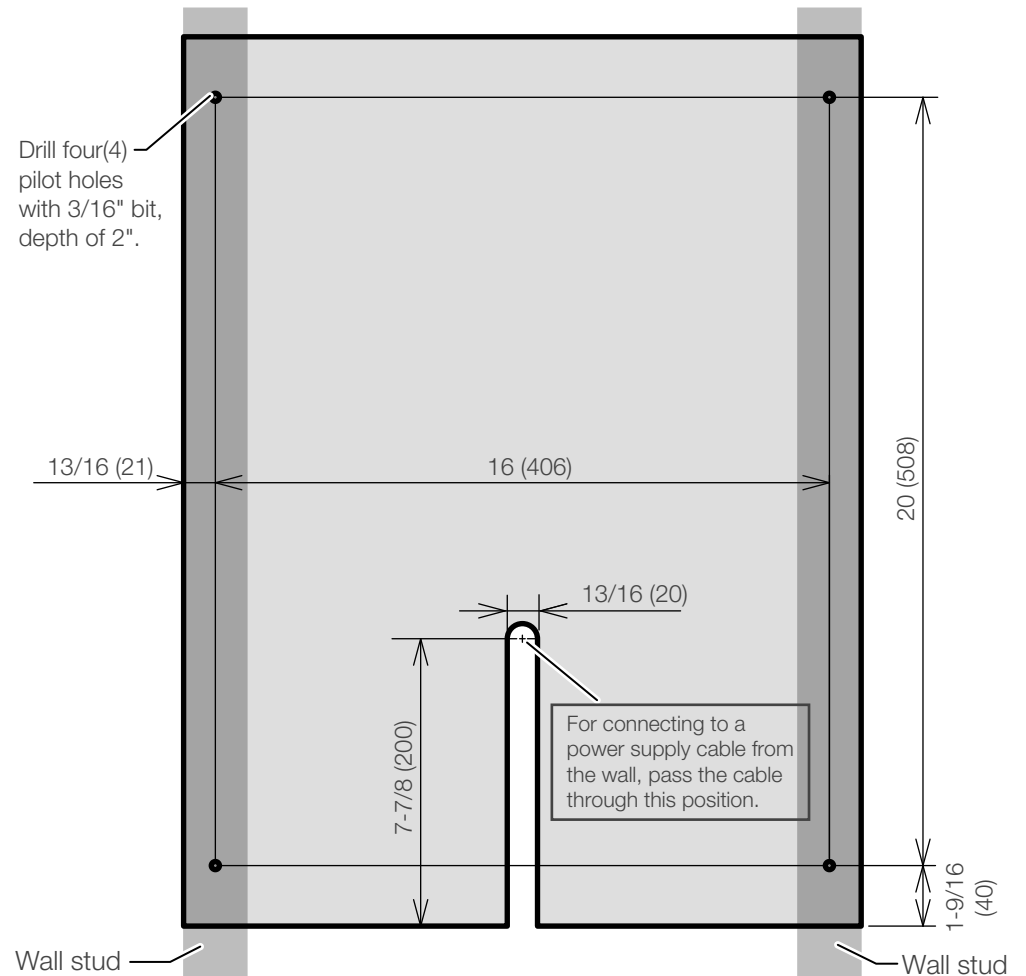

# WALL MOUNT [ Assembly procedure for installation ]

(AL-D248G)

## STEP2 : Mount wall plate assembly.

- ① Mount wall plate assembly to the studs, with lag bolts (4 pieces) and washers (4 pieces).
- ② Remove PCB cover by removing screws (2 pieces) from it.
- ③ Place a level on top of Pole Receptacle and adjust the level with leveling bolts (4 pieces).
- ④ Remove the retainer metal from top of pole receptacle (2 screws).

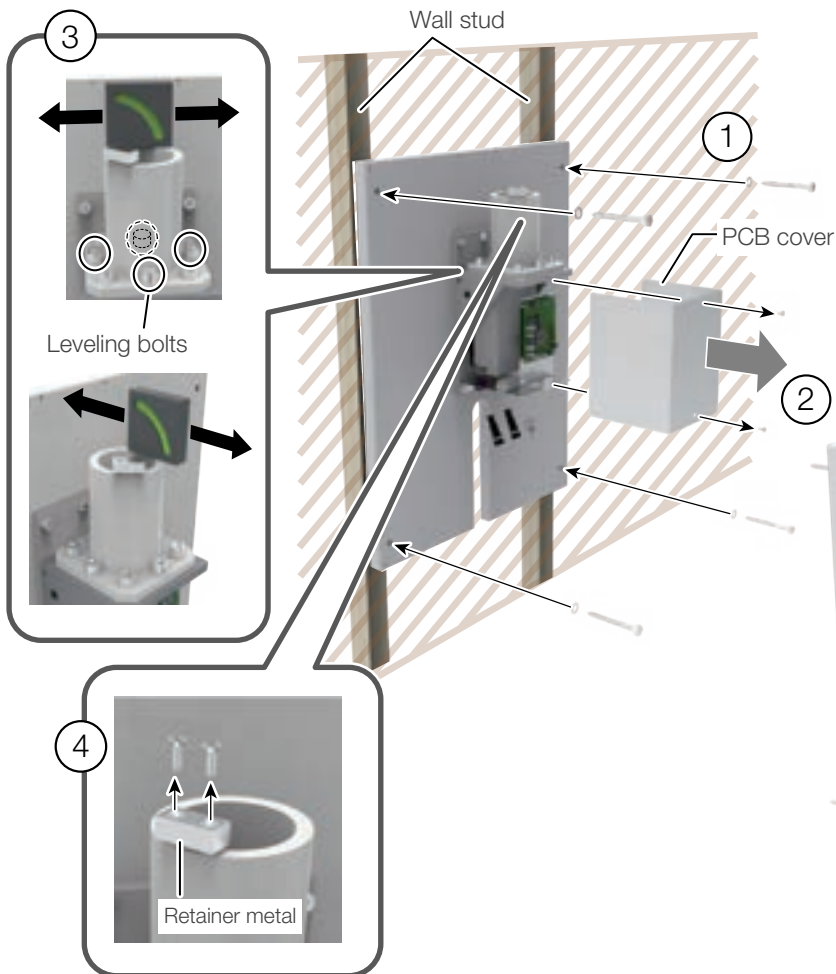

## STEP3 : Light Pole Mounting.

- ⑤ Insert the connection cable through lightpole receptacle.
- ⑥ Pass the connection cable through the pole receptacle and insert the long side of the pole to it.
- ⑦ Re-attach retainer metal which was removed in step ④.
- ⑧ Connect the connector of the connection cable as shown in the figure.
- ⑨ Slide pole disc onto the lightpole from the shorter end of the pole.
- ⑩ Loosen hex socket set screw (4 pieces) on the light pole.

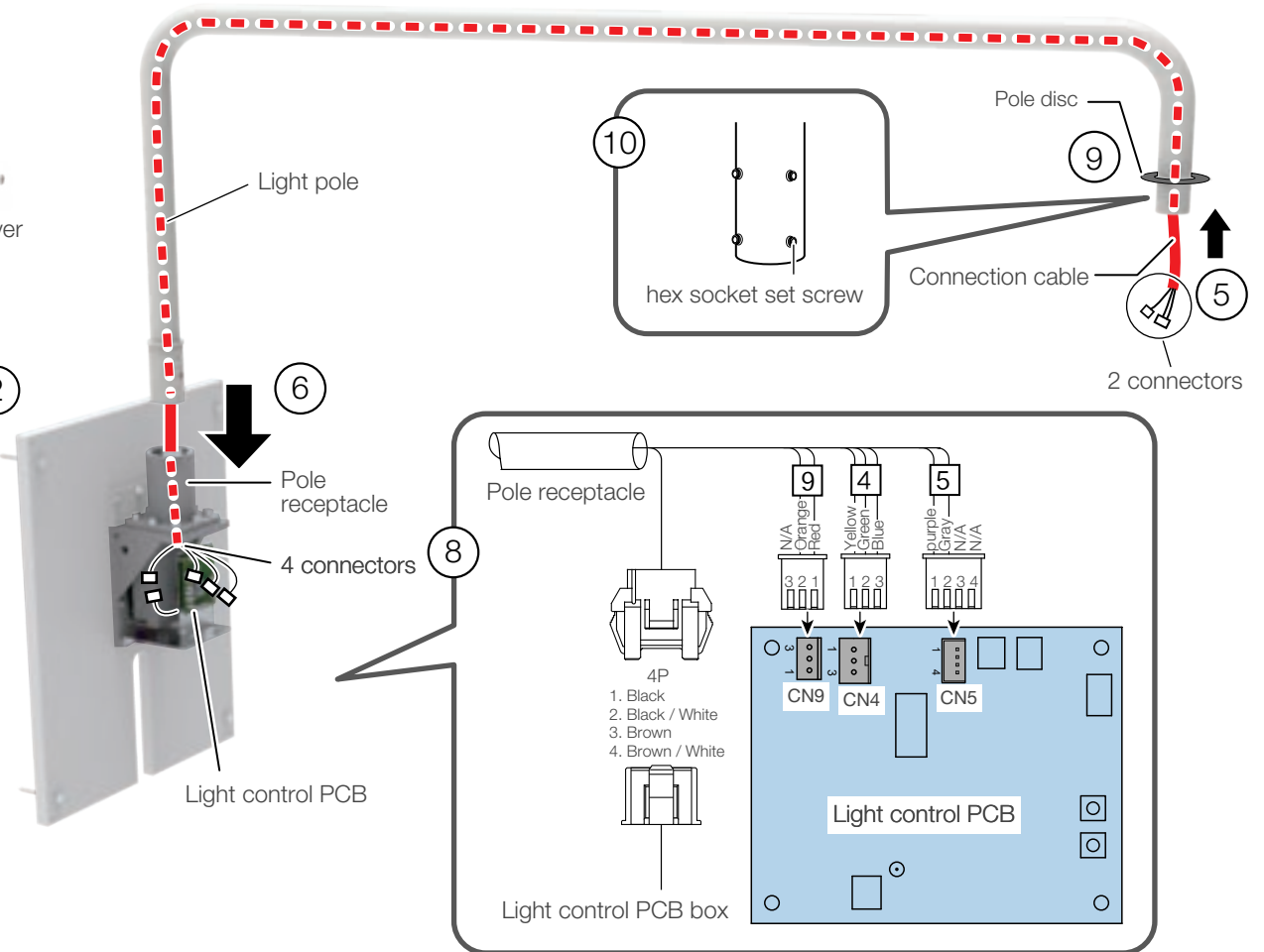

# WALL MOUNT [ Assembly procedure for installation ]

(AL-D248G)

## STEP4 : Attach the balance arm to the light pole.

- ① Join connectors from connection cable to those from balance arm.
- ② Insert balance arm stem into light pole.
- ③ Determine the range of the balance arm and fix the hex socket set screw loosened in the STEP3.

## STEP5 : Attach the light head.

- ④ Remove the yoke cover from the light head. (2 countersunk screws)
- ⑤ Pass the lead wire in the arm through the light head and attach the light head to the arm. (2 pan head screws fixed at the attaching point.)
- ⑥ Connect the connectors in the arm to the light head connectors. (2 pcs.)

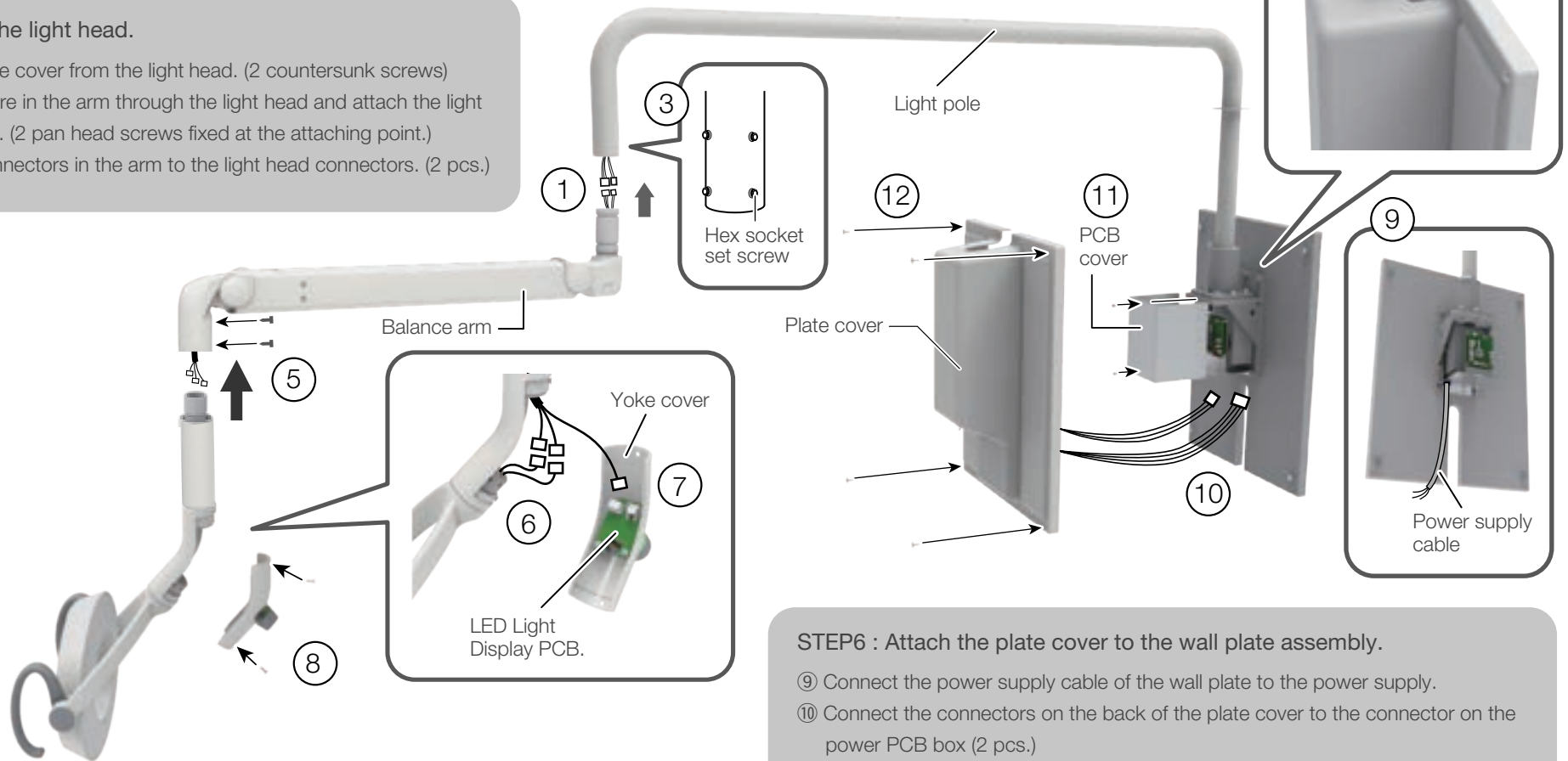

- ⑦ Connect the connector from the arm to the LED control PCB behind the yoke cover. (1 pc.)
- ⑧ Re-attach the yoke cover.

## STEP6 : Attach the plate cover to the wall plate assembly.

- ⑨ Connect the power supply cable of the wall plate to the power supply.
- ⑩ Connect the connectors on the back of the plate cover to the connector on the power PCB box (2 pcs.)
- ⑪ Re-attach the PCB cover.
- ⑫ Set the plate cover over the wall plate and fix it with the tapping screws (4 pcs.).
- ⑬ Attach the top cover and fix it with the two tapping screws with washers (2 pcs.).
- ⑭ Slide pole disc down to cover the opening around light pole on the top cover.

# QUOLIS UNIT MOUNT

(AL-D246G-QU)









## QUOLIS UNIT MOUNT [ Necessary tools and supplied parts ]

(AL-D246G-QU)

### Necessary tools

No.	Tool name	QTY.
1	Phillips screwdriver No. 1, 2	1 for each
2	Hex key wrench; width across flats: 2mm/2.5mm/3mm/4mm/6mm/8mm/10mm	1 for each
3	Long nose pliers	1

### Supplied parts

No.	Part name		QTY.
1	Light pole		1
2	Connection cable		1
3	P.C.Board unit		1
4	Pan head screw, 3P, M5 x 12, plated		2
5	Switch box		1
6	Pan head screw, 3P, M4 x 8, plated		2
7	Adjustment rod		1

# QUOLIS UNIT MOUNT [ Assembly procedure for installation ]

(AL-D246G-QU)

## STEP1 : Attach the mounting bracket

(Only specification without doctor unit.  
For specifications with a doctor unit, go to STEP2.)

- ① Hook the support bolt on the mounting bracket to the chair.
- ② Temporarily fasten the mounting bracket with cap bolts (4 pieces).
- ③ Attach the hex socket set screws (4 pieces) and horizontally adjust the mounting bracket.
- ④ Tighten the bolts in ② and fix the mounting bracket.

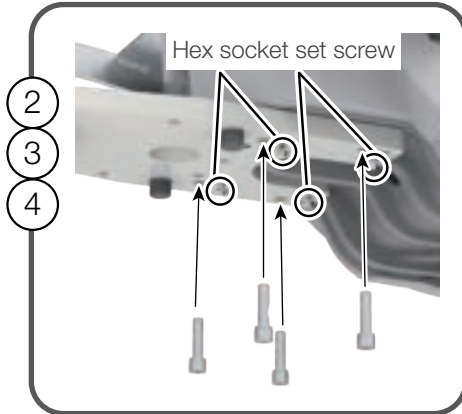
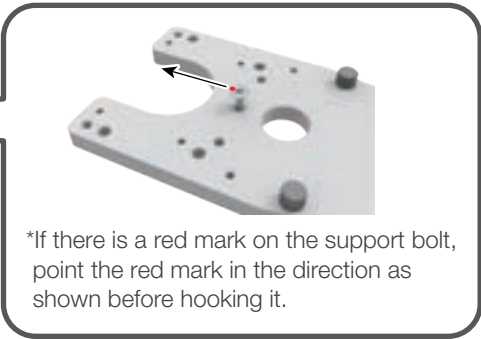
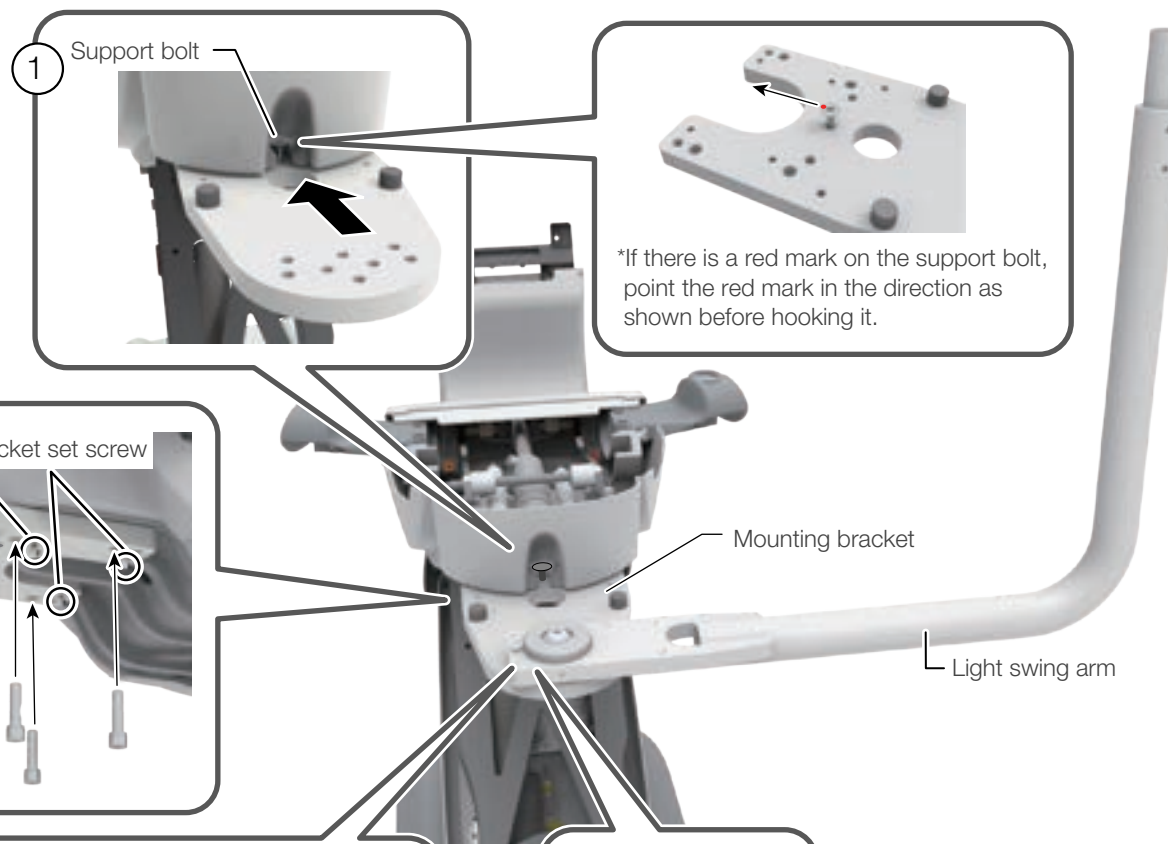

## STEP2 : Attach the light swing arm

- ⑤ Attach the light swing arm to the mounting bracket as shown in the figure.
- ⑥ Set the brake shoe, spring and hex socket set screw.
- ⑦ Set the light swing arm to the desired angle and fix it with the locking pin.

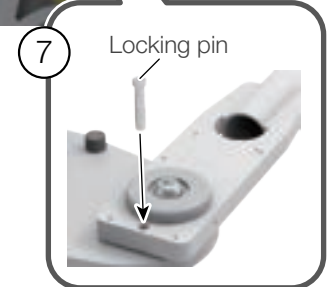
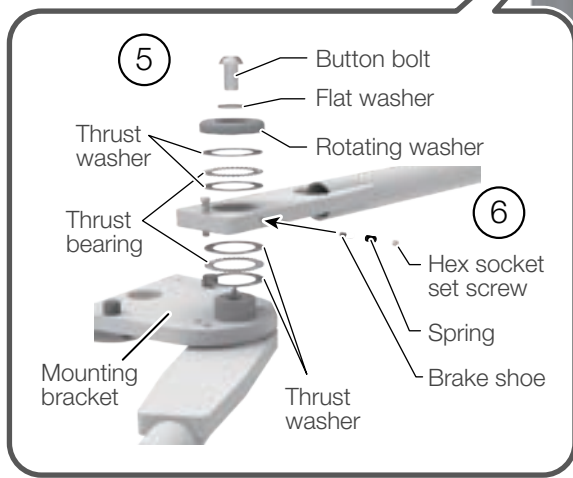

# QUOLIS UNIT MOUNT [ Assembly procedure for installation ]

(AL-D246G-QU)

## STEP3 : Attach the dental light to the light pole.

- ① Pass the lead cable through the light pole.
- ② Insert the balance arm joint to the light pole, and fix it with the button bolt attached on the attaching point.

## STEP4 : Mount the light pole.

- ③ Loosen the hex socket set screw (1 piece).
- ④ Feed the light lead cable through the swing arm and pull the end of the lead cable from the lower end of the swing arm.
- ⑤ Mount the light pole onto swing arm.
- ⑥ Adjust the brake with the hex socket set screw loosened in the ③.

## STEP5 : Attach the switch box.

- ⑦ Remove the switch box cover. (2 pan head screws)
- ⑧ Attach the switch box onto the swing arm with two pen head screws M4 x 8. Fix together the ground wire of the connection cable.
- ⑨ Connect the connector from the connection cable to the connector from the switch box (1pc.).
- ⑩ Connect the connectors from the connection cable and the connectors from the lead wire in the light (2 pcs.).
- ⑪ Place all cables in the switch box and attach the cover for switch box with reverse order of ⑦.

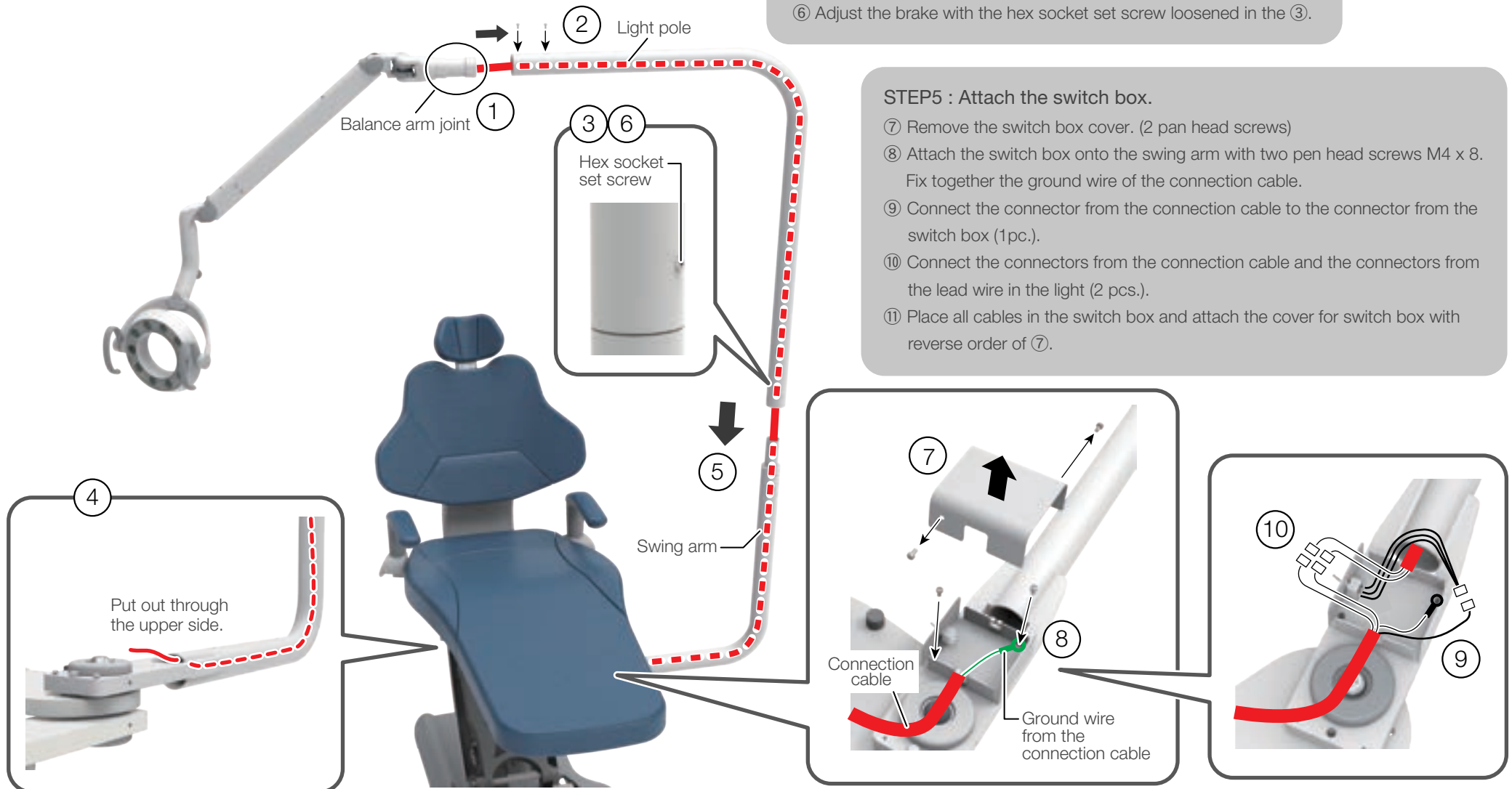

# QUOLIS UNIT MOUNT [ Assembly procedure for installation ]

(AL-D246G-QU)

## STEP6 : Attach the P.C.Board unit.

- ① Attach the P.C.Board unit to the chair base (2 pan head screws M5).
- ② Pass the connection cable through the swing arm bracket hole and pass it through the lower part of the chair as shown in the figure

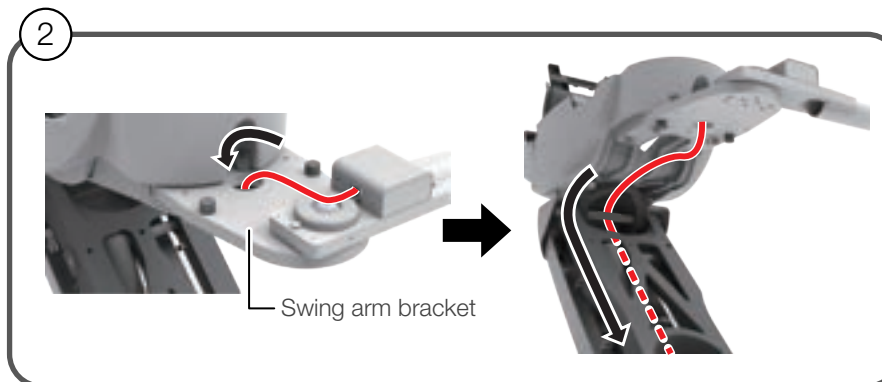
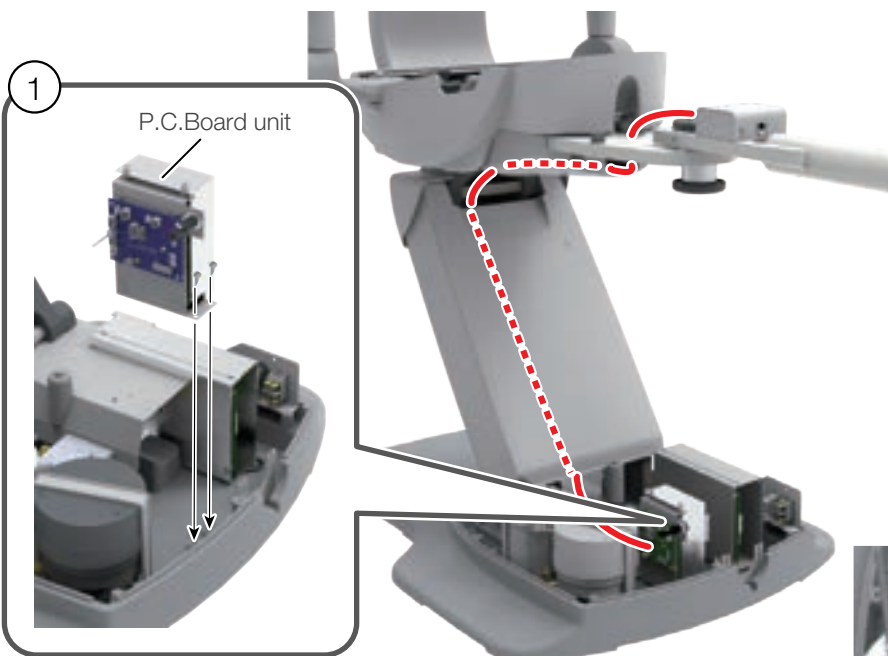

- ③ Attach the ground wire of the connection cable.
- ④ Connect the connectors from the connection cable to the light control PCB as shown in the figure.
- ⑤ Connect the connectors from the connection cable to the connector from the P.C.Board unit.
- ⑥ Connect the connectors from the chair PCB and chair terminal block to the connector from the P.C.Board unit.

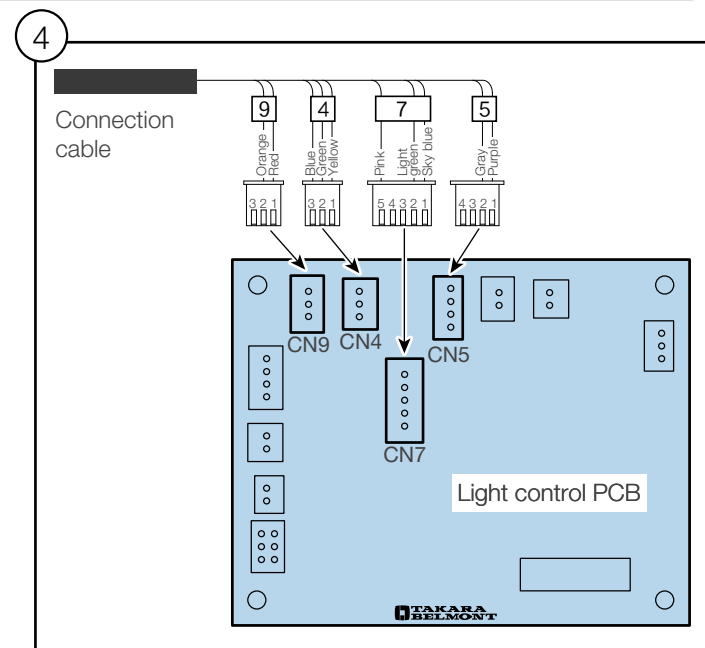
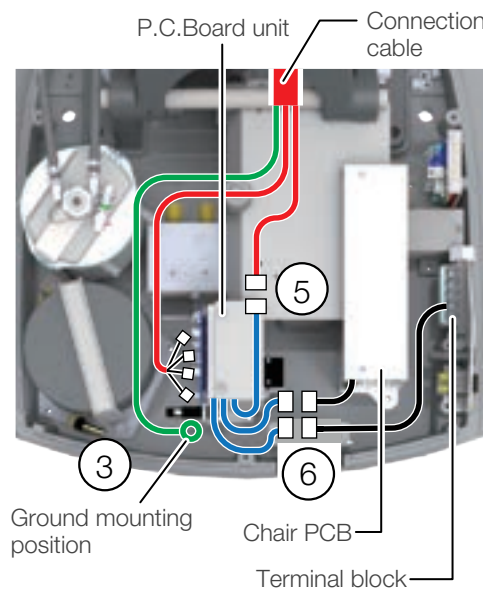

# EVOGUE UNIT MOUNT

(AL-D246G-EV)

[Cuspidor Mount]







# EVOGUE UNIT MOUNT (Cuspidor Mount) [ Necessary tools and supplied parts ]

(AL-D246G-EV)

## Necessary tools

No.	Tool name	QTY.
1	Phillips screwdriver No. 1, 2	1 for each
2	Hex key wrench; width across flats: 2 mm / 2.5mm / 4mm	1 for each
3	Long nose pliers	1

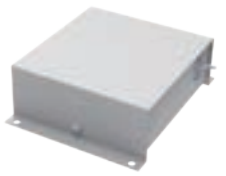
## Supplied parts

No.	Part name	QTY.
1	Light pole 	1
2	Connection cable *Not necessary when connecting to the BEL-50 chair. 	1
3	Power supply box 	1
4	Switch box 	1
5	Pan head screw, M4 x 8, plated 	4
6	Adjustment rod 	1

# EVOGUE UNIT MOUNT (Cuspidor Mount) [ Assembly procedure for installation ]

(AL-D246G-EV)

## STEP1 : Attach the dental light to the light pole.

- ① Pass the lead cable through the light pole.
- ② Insert the balance arm joint into the light pole and remove the button screw (2 pieces) set at the connecting points and fix it with them.

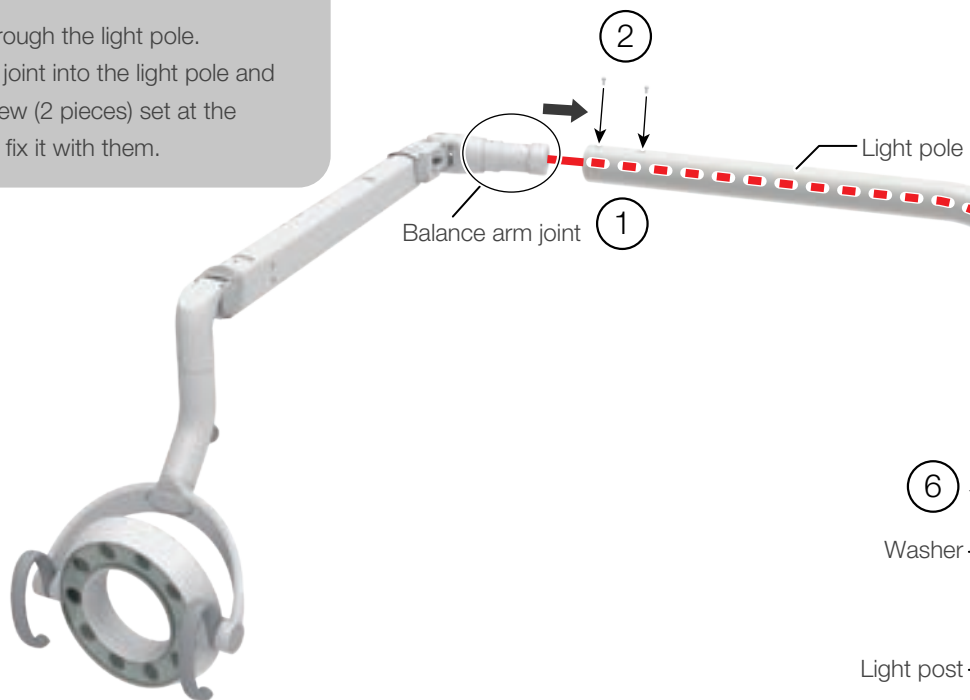

## STEP2 : Attach the light to the Cuspidor unit.

- ③ Set the washer to the light post.
- ④ Loosen the hex socket set screw (1 piece).
- ⑤ Feed the light lead cable through the light post and pull the end of the lead cable from side of the cuspidor post.
- ⑥ Mount the light pole onto light post.
- ⑦ Adjust the brake with the hex socket set screw loosened in the ④.

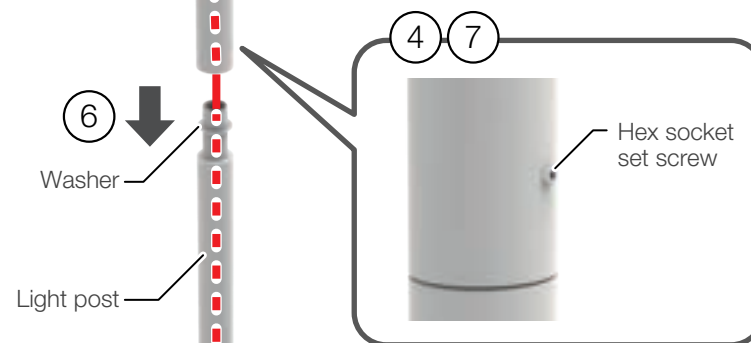

## STEP3 : Attach the switch box.

- ⑧ Attach the switch box to the cuspidor unit with pan head screws (4 pcs.).

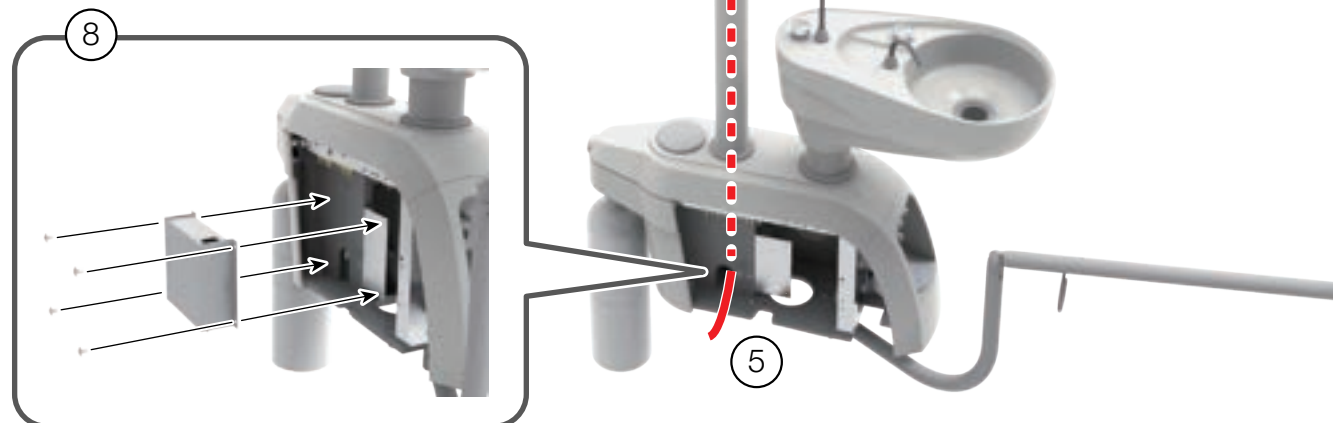

# EVOQUE UNIT MOUNT (Cuspidor Mount) [ Assembly procedure for installation ]

(AL-D246G-EV)

STEP4 : Connect the wirings in the switch box.

① Connect the connectors from connection cable and lead wire from the light as shown in the figure.

\*For connection to the BEL-50 chair, connect the cable from Umbilical hose on the mounting bracket.  
(Connection cable (Supplied parts No.2) is not used.)

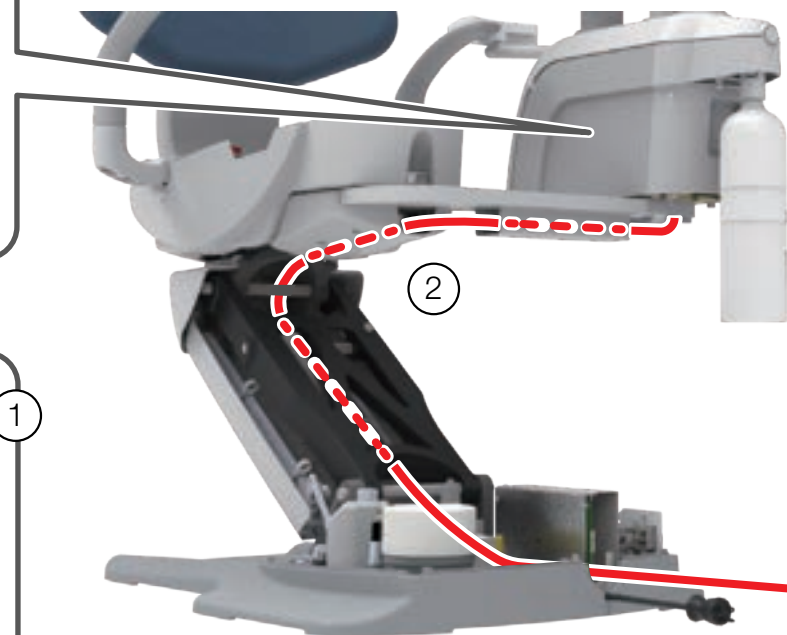
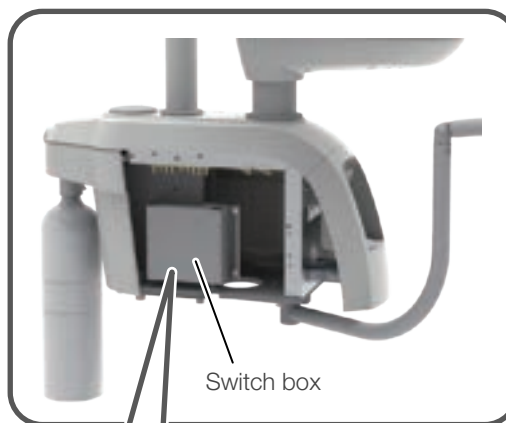

② Pass the connection cable through the hole for the swing arm bracket and pass it to chair lower front.

Combine with Q3300/Q5500 Chair

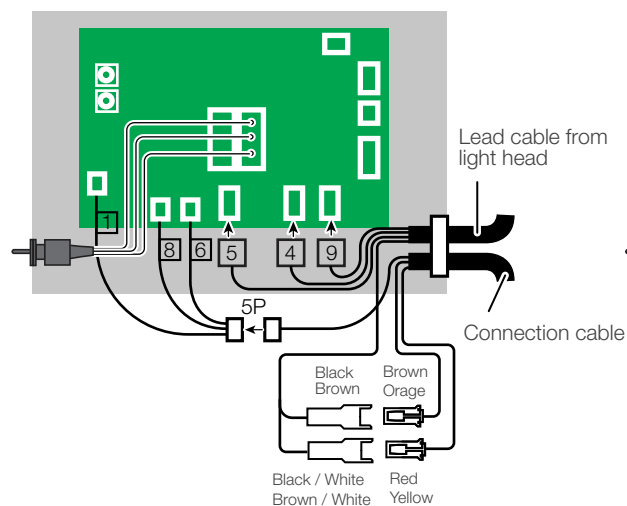

Combine with BEL-50 Chair

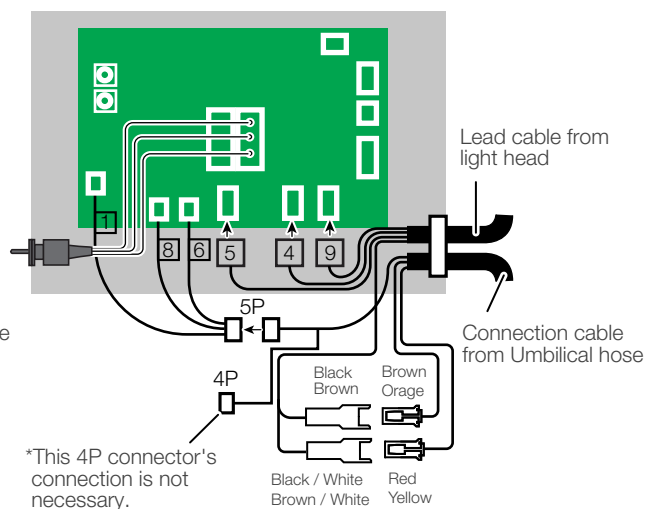

①

# EVOQUE UNIT MOUNT (Cuspidor Mount) [ Assembly procedure for installation ]

(AL-D246G-EV)

STEP5 : Attach the power supply box.

- ① Attach the power supply box to the junction unit.
- ② Connect the connector from the power supply box to connection cable from cuspidor unit.
- ③ Pipe the air and water supply in the junction unit.

Combine with BEL-50 Chair

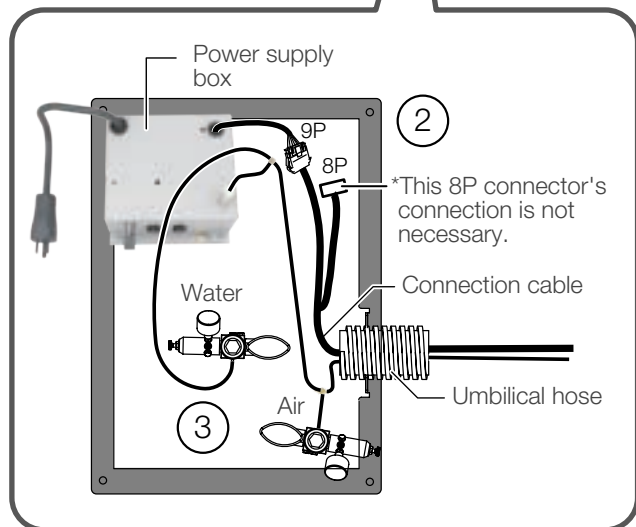
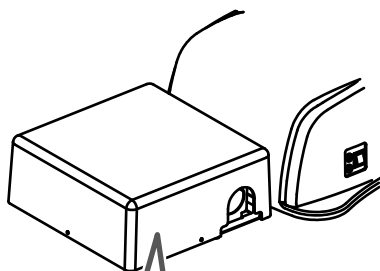

Combine with Q3300 Chair

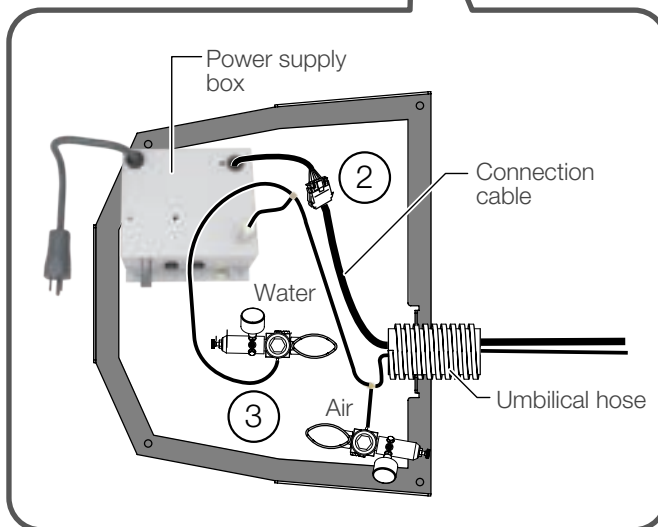
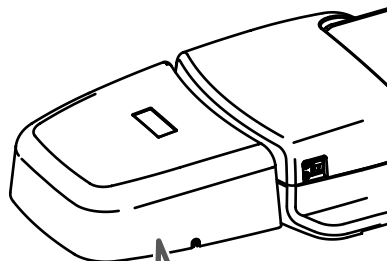

Combine with Q5500 Chair

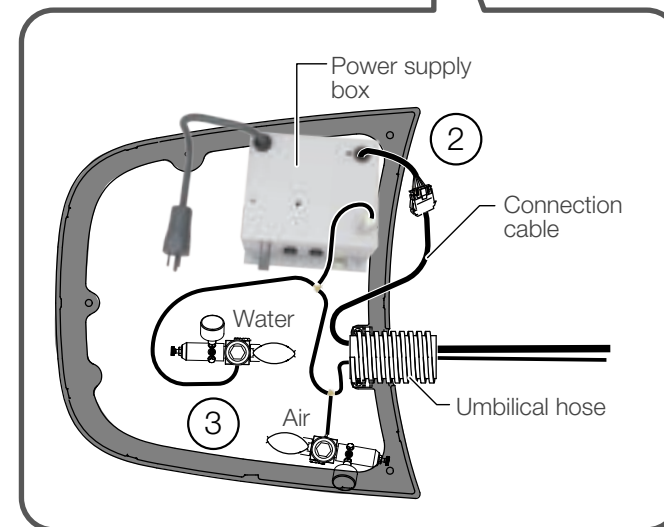
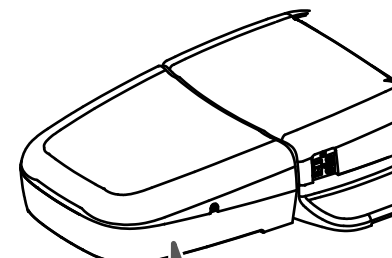

# EVOGUE UNIT MOUNT

(AL-D246G-EV)

[Swing Arm Mount]









## EVOGUE UNIT MOUNT (Swing Arm Mount) [ Necessary tools and supplied parts ]

(AL-D246G-EV)

### Necessary tools

No.	Tool name	QTY.
1	Phillips screwdriver No. 1, 2	1 for each
2	Hex key wrench; width across flats: 2 mm / 2.5mm / 4mm / 6mm / 8mm / 10mm	1 for each
3	Long nose pliers	1

### Supplied parts

No.	Part name		QTY.
1	Light pole		1
2	Connection cable		1
3	Power supply box		1
4	Switch box		1
5	Pan head screw, M4 x 8, plated		4
6	Adjustment rod		1

# EVOGUE UNIT MOUNT (Swing Arm Mount) [ Assembly procedure for installation ]

(AL-D246G-EV)

**STEP1 : Attach the dental light to the light pole.**

- ① Pass the lead cable through the light pole.
- ② Insert the balance arm joint into the light pole and remove the button screw (2 pieces) set at the connecting points and fix it with them.

**STEP2 : Attach the light swing arm to the chair.**

- ③ Hook the support bolt on the mounting bracket to the chair.
- ④ Fix the mounting bracket with cap bolts (4 pieces).
- ⑤ Set the light swing arm to the desired angle and fix it with the locking pin.

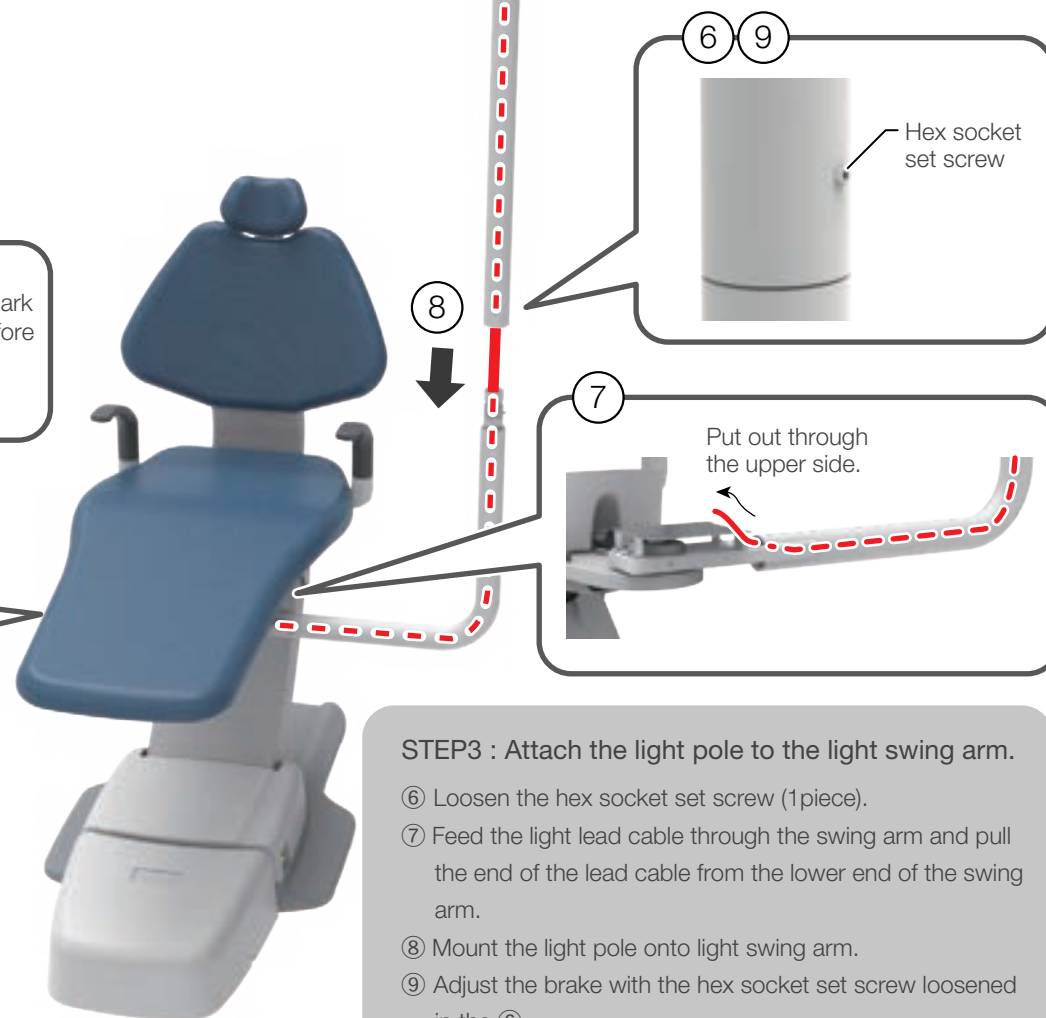
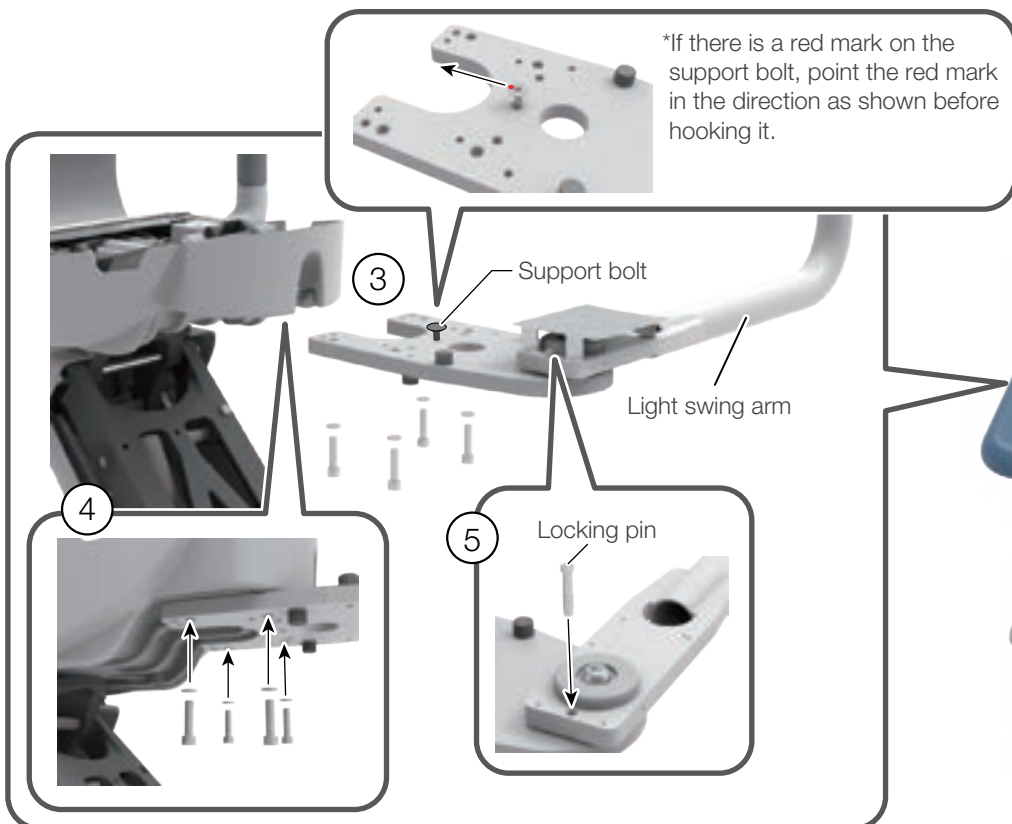
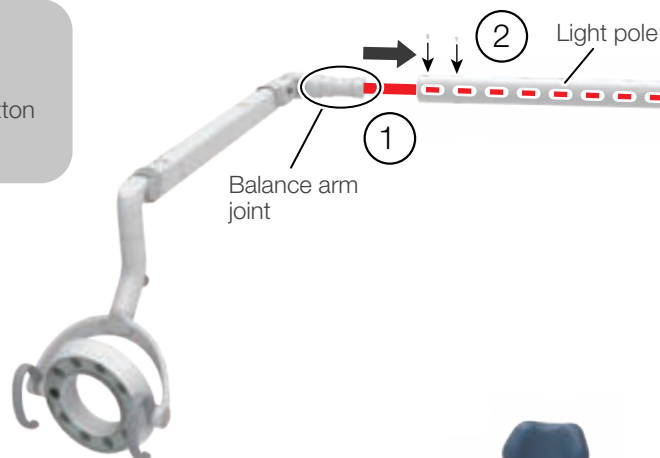

**STEP3 : Attach the light pole to the light swing arm.**

- ⑥ Loosen the hex socket set screw (1 piece).
- ⑦ Feed the light lead cable through the swing arm and pull the end of the lead cable from the lower end of the swing arm.
- ⑧ Mount the light pole onto light swing arm.
- ⑨ Adjust the brake with the hex socket set screw loosened in the ⑥.

# EVOGUE UNIT MOUNT (Swing Arm Mount) [ Assembly procedure for installation ]

(AL-D246G-EV)

STEP4 : Attach the switch box.

- ① Attach the switch box to the light pole bracket with truss screws (4 pcs.).

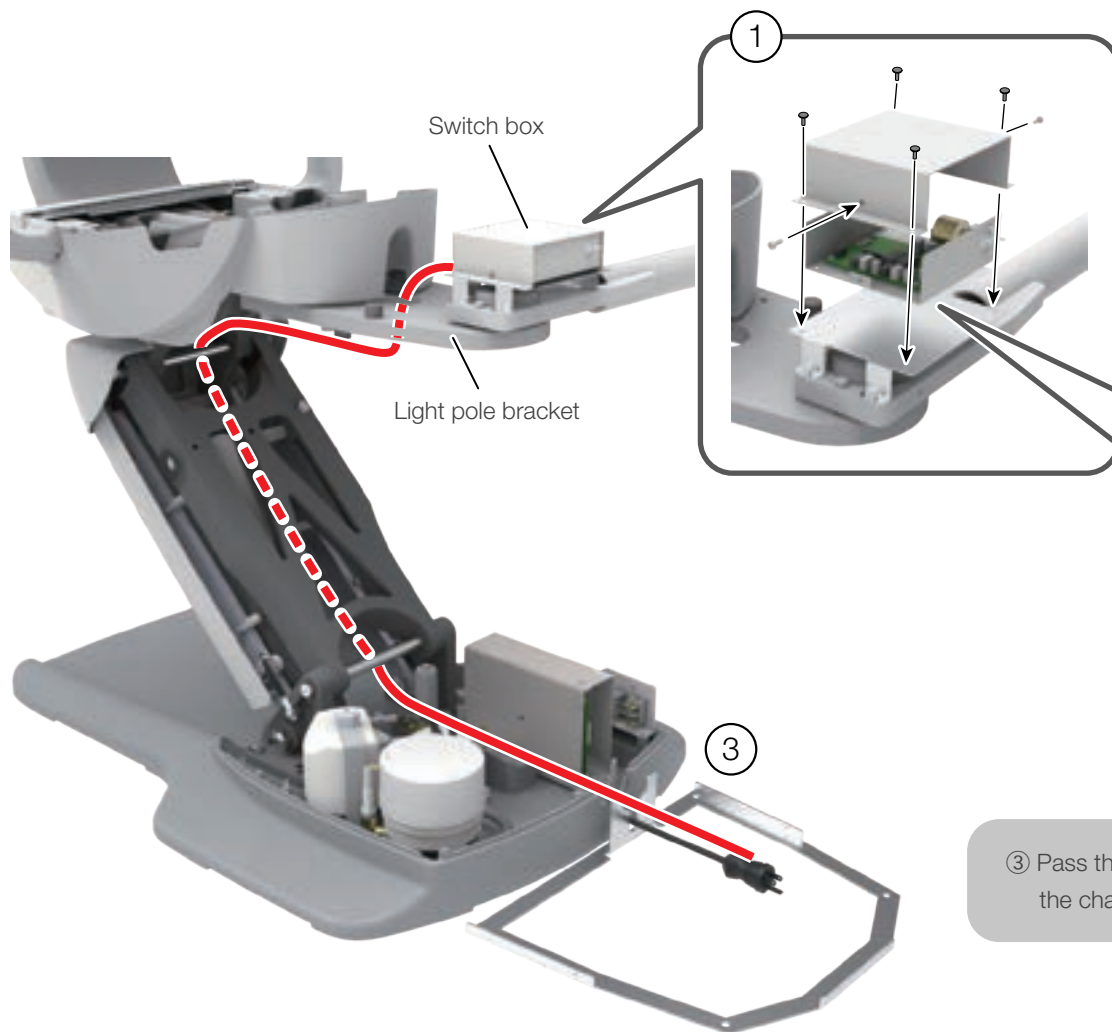

STEP5 : Connect the wirings in the switch box.

- ② Connect the connectors from connection cable and lead wire from the light as shown in the figure.

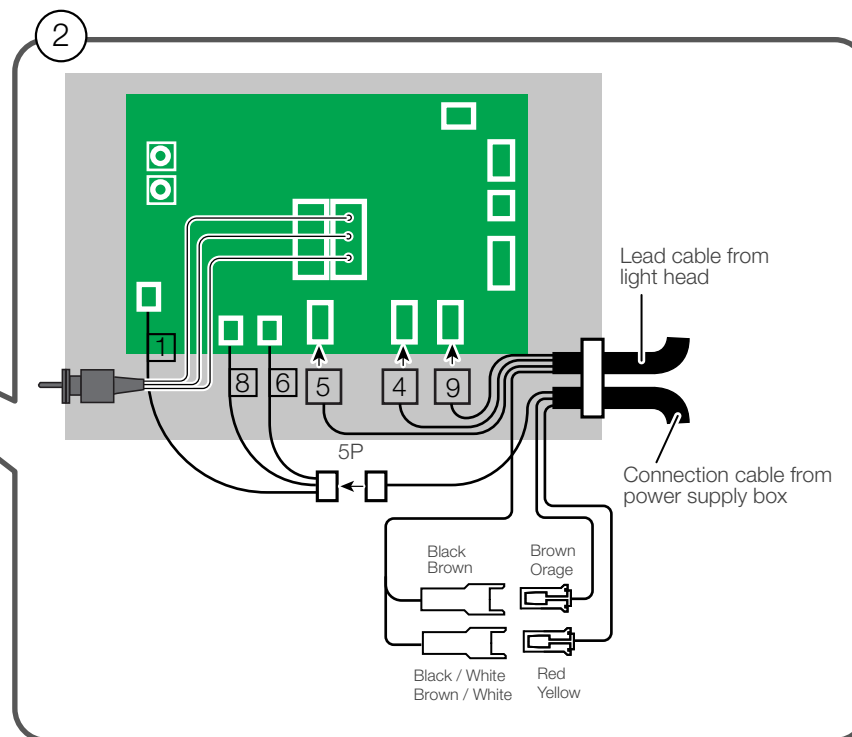

- ③ Pass the connection cable through the chair and to the junction unit.

# EVOQUE UNIT MOUNT (Swing Arm Mount) [ Assembly procedure for installation ]

(AL-D246G-EV)

STEP6 : Attach the power supply box.

- ① Attach the power supply box to the junction unit.
- ② Connect the connector from the power supply box to connection cable from switch box.
- ③ Pipe the air supply in the junction unit.

Combine with BEL-50 Chair

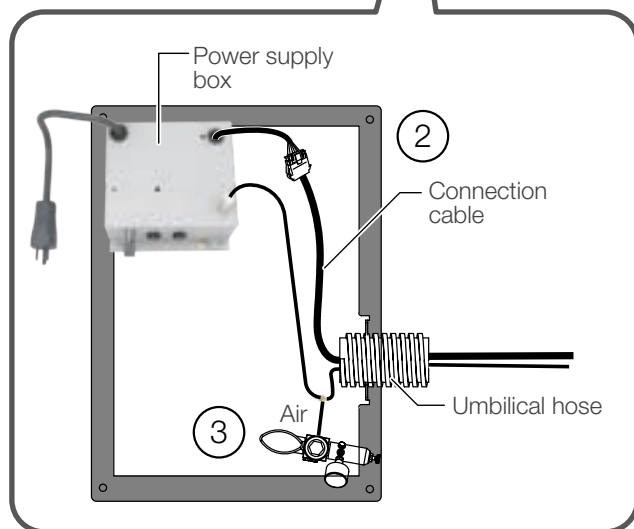
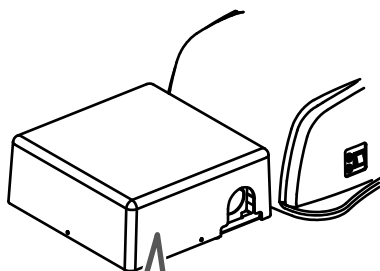

Combine with Q3300 Chair

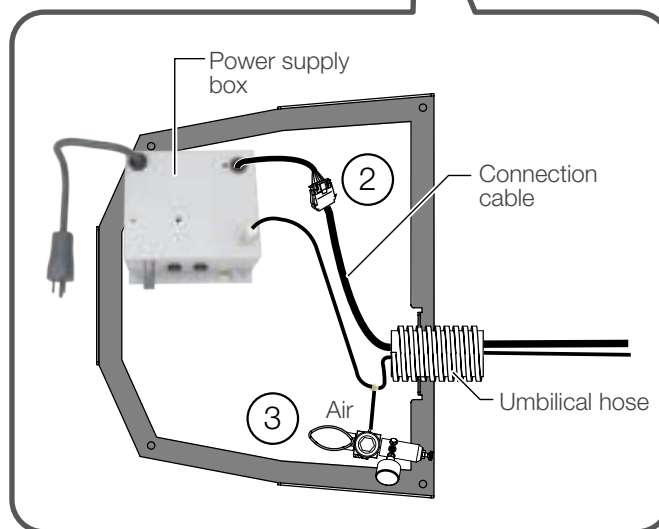
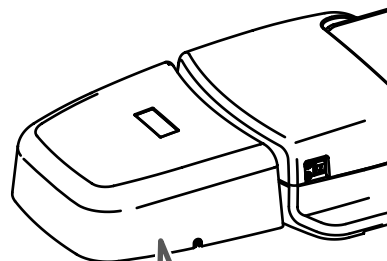

Combine with Q5500 Chair

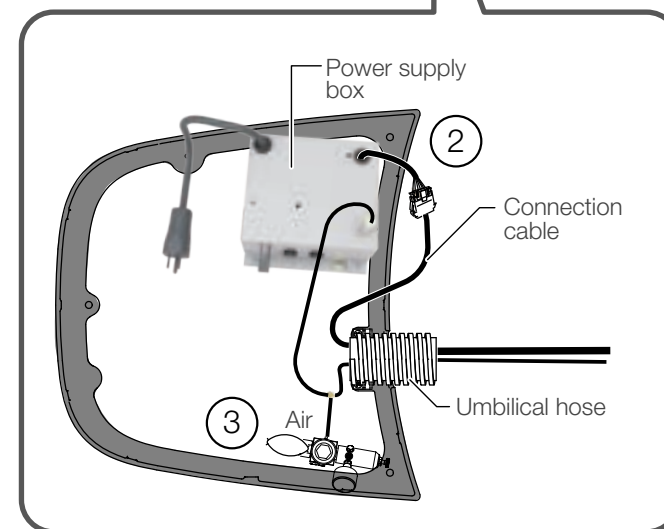
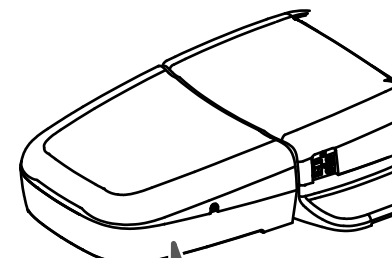

# X-CALIBUR UNIT MOUNT

(AL-D249W-XN)

[Cuspidor Mount]







## X-CALIBUR UNIT MOUNT (Cuspidor Mount) [ Necessary tools and supplied parts ]

(AL-D249W-XN)

### Necessary tools

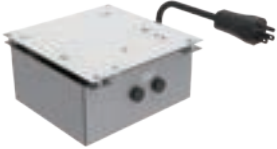
No.	Tool name	QTY.
1	Phillips screwdriver No. 1, 2	1 for each
2	Hex key wrench; width across flats: 2 mm / 2.5mm / 4mm	1 for each
3	Long nose pliers	1

### Supplied parts

No.	Part name	Image	QTY.
1	Light pole		1
2	Power supply box		1
3	Switch box		1
4	Pan head screw, M4 x 8, plated		2
5	Brake shoe		1
6	Adjustment rod		1

# X-CALIBUR UNIT MOUNT (Cuspidor Mount) [ Assembly procedure for installation ]

(AL-D249W-XN)

## STEP1 : Attach the dental light to the light pole.

- ① Pass the lead cable through the light pole.
- ② Insert the balance arm joint into the light pole and remove the button screw (2 pieces) set at the connecting points and fix it with them.

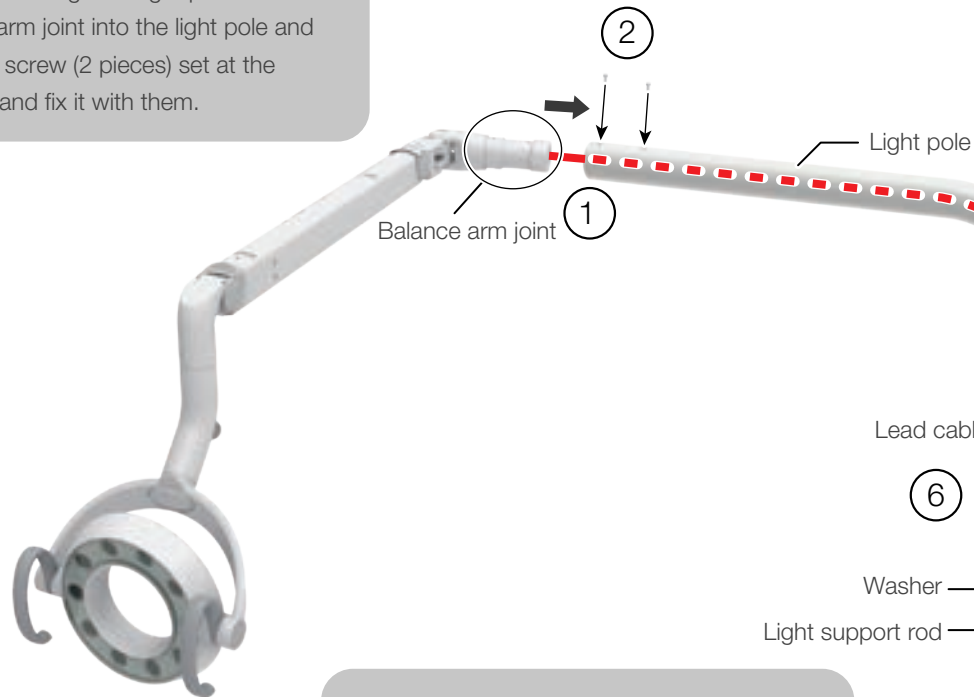

## STEP2 : Attach the light to the cuspidor unit.

- ③ Set the washer to the light support rod.
- ④ Remove the hex socket set screw (M6x5, SUS, 1 piece).
- ⑤ Feed the light lead cable through the light support rod and pull the end of the lead cable from side of the cuspidor post.
- ⑥ Mount the light pole onto light support rod.
- ⑦ Insert the brake shoe and adjust the brake with the hex socket set screw removed in ③.

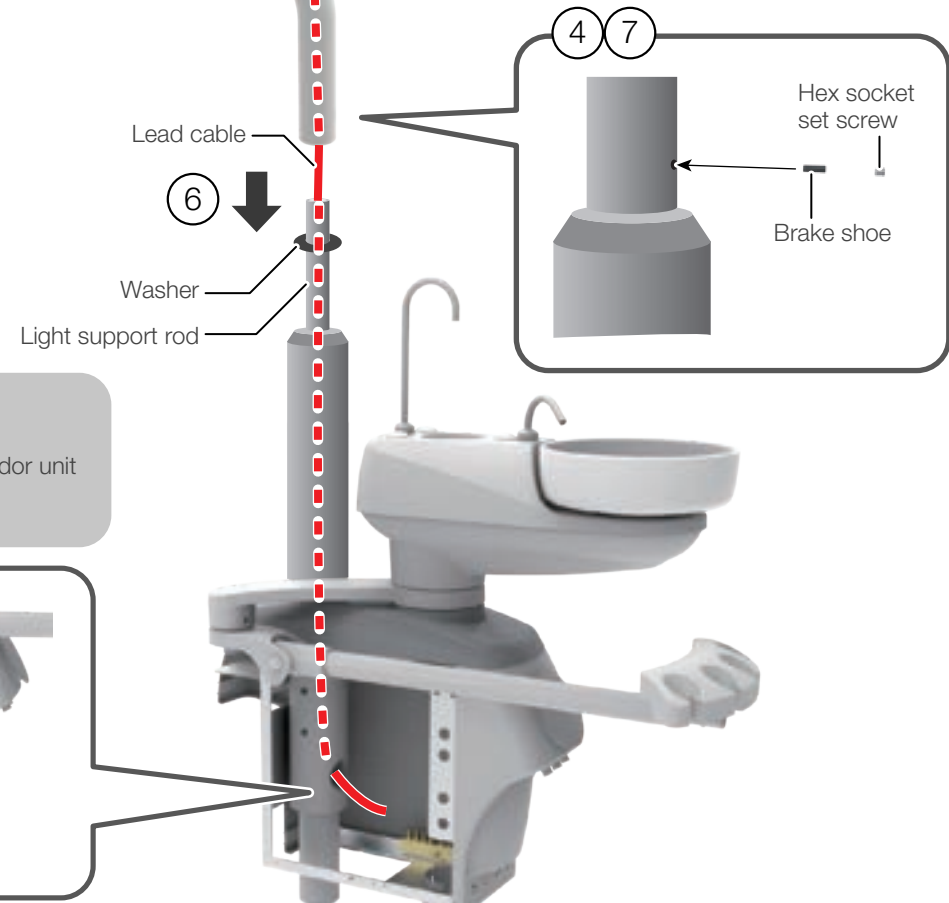

## STEP3 : Attach the switch box.

- ⑧ Attach the switch box to the cuspidor unit with pan head screws (2 pcs.).

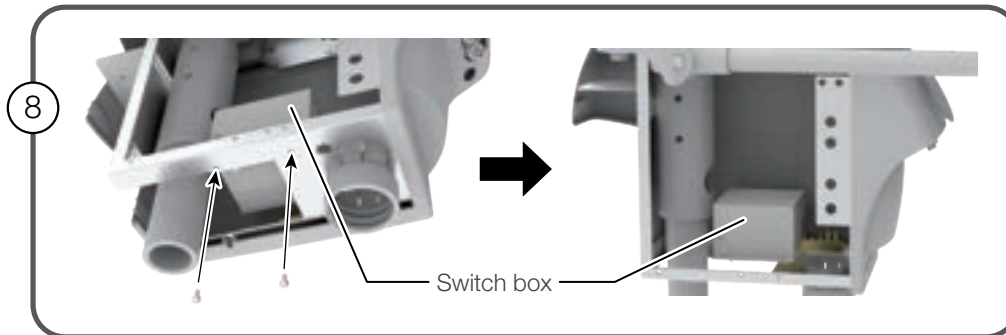

# X-CALIBUR UNIT MOUNT (Cuspidor Mount) [ Assembly procedure for installation ]

(AL-D249W-XN)

**STEP4 : Connect the wirings in the switch box.**

- ① Connect the connectors from connection cable and lead wire from the light as shown in the figure.

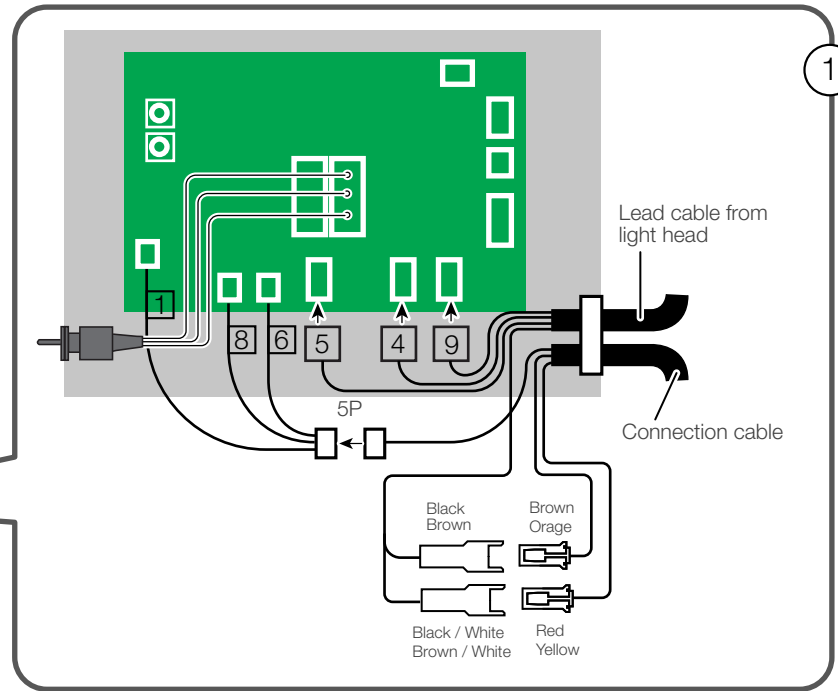
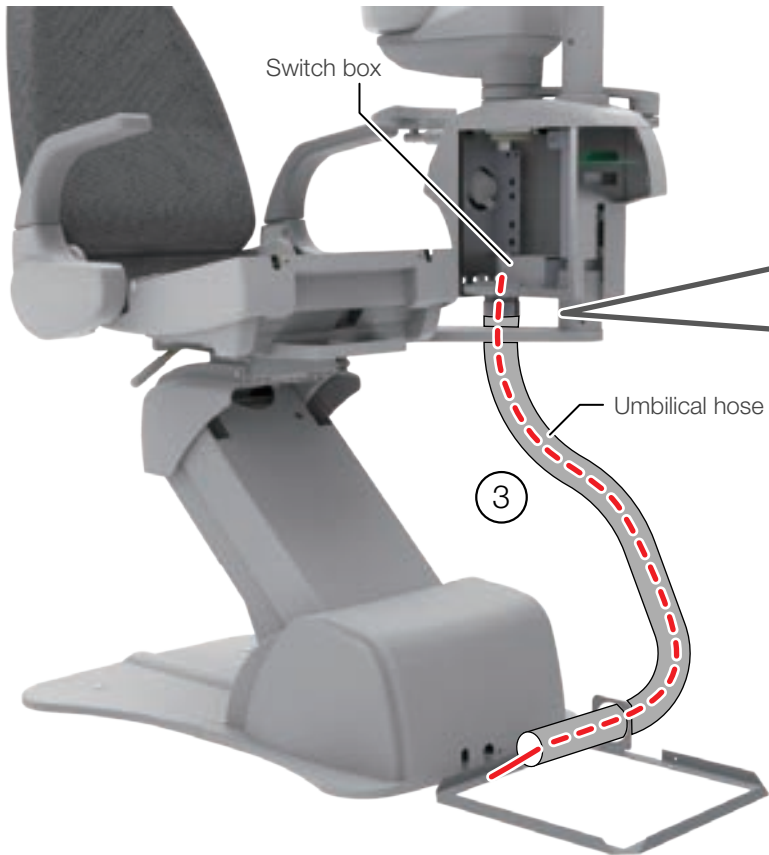

**STEP5 : Attach the power supply box.**

- ② Attach the power supply box to the junction unit.
- ③ Pass the connection cable through the umbilical hose and to the junction unit.
- ④ Connect the connector from the power supply box to connection cable from cuspidor unit.
- ⑤ Pipe the air and water supply in the junction unit.

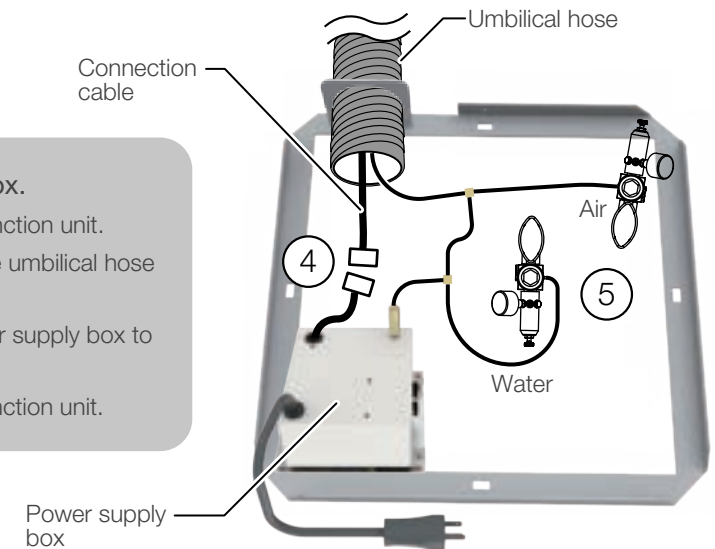

# X-CALIBUR UNIT MOUNT

(AL-D249W-X)

[Swing Arm Mount]

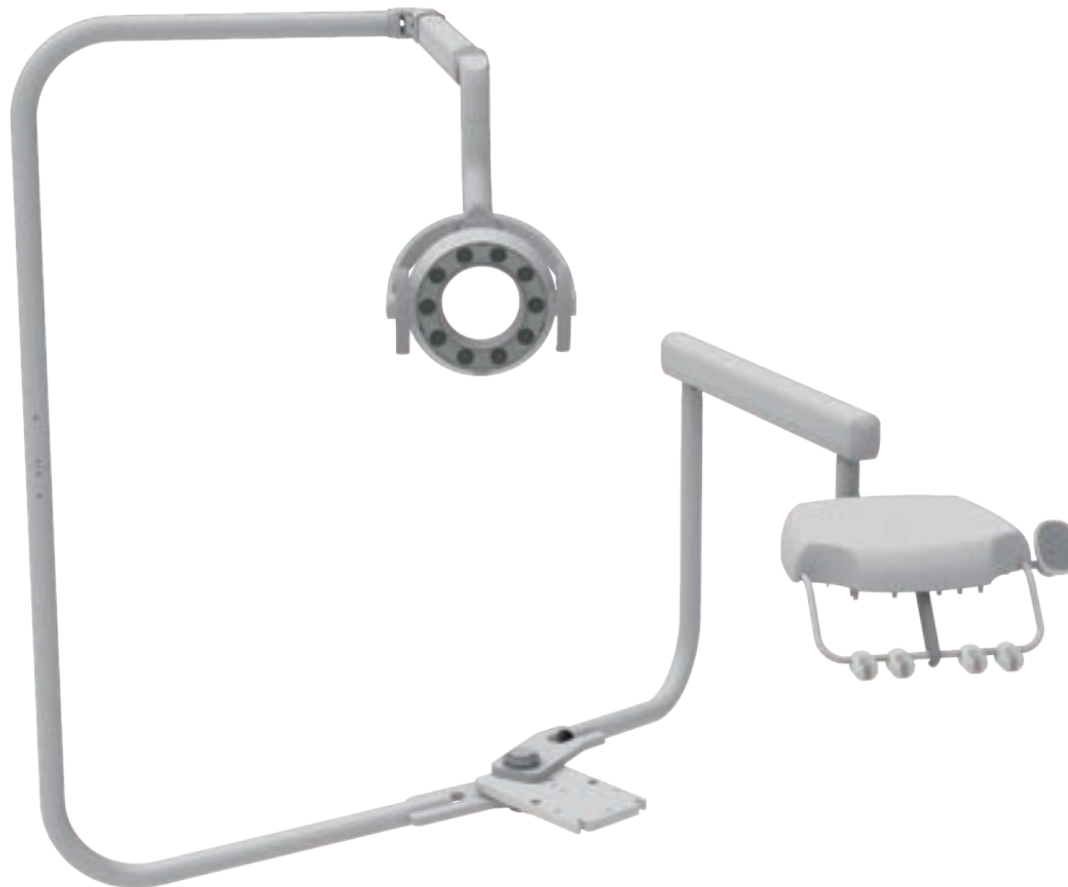





## X-CALIBUR UNIT MOUNT (Swing Arm Mount) [ Necessary tools and supplied parts ]

(AL-D249W-X)

### Necessary tools

No.	Tool name	QTY.
1	Phillips screwdriver No. 1, 2	1 for each
2	Hex key wrench; width across flats: 2 mm / 2.5mm / 4mm / 6mm / 8mm	1 for each
3	Long nose pliers	1

### Supplied parts

No.	Part name		QTY.
1	Light pole		1
2	Power supply box		1
3	Switch box		1
4	Pan head screw, M4 x 8, plated		4
5	Adjustment rod		1

# X-CALIBUR UNIT MOUNT (Swing Arm Mount) [ Assembly procedure for installation ]

(AL-D249W-X)

## STEP1 : Attach the dental light to the light pole.

- ① Pass the lead cable through the light pole.
- ② Insert the balance arm joint into the light pole and remove the button screw (2 pieces) set at the connecting points and fix it with them.

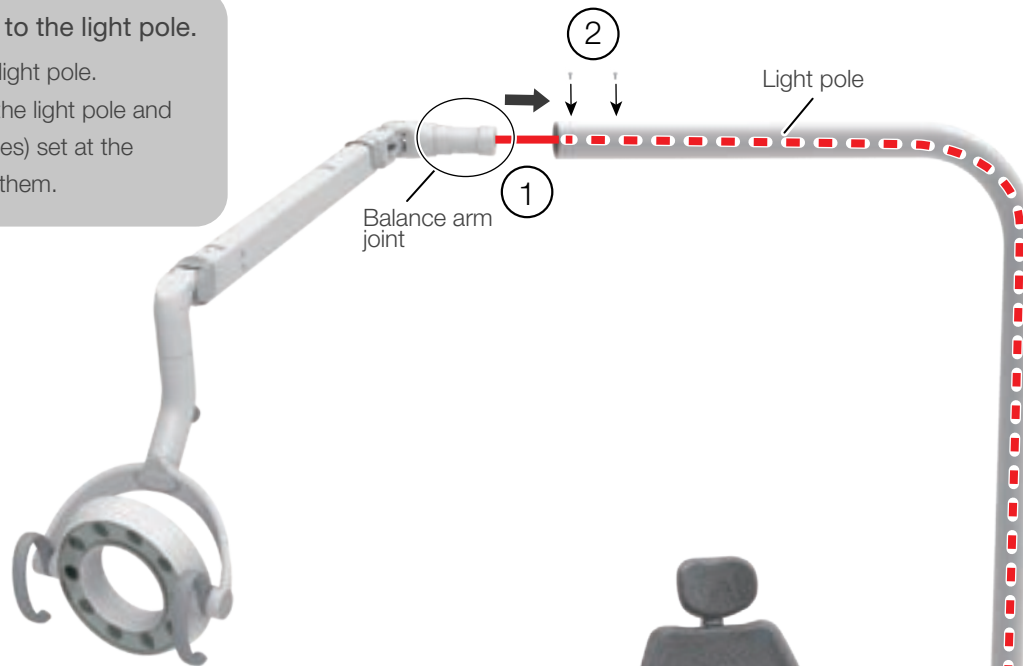

## STEP2 : Attach the light swing arm to the chair.

- ③ Temporarily fix the 2 cap bolts 2P to the chair bracket.
- ④ Align the cutout of the mounting bracket with the bolts temporarily fixed with procedure ③, and fix them with temporarily fixed bolts (2 pieces) and cap bolts (2 pieces).

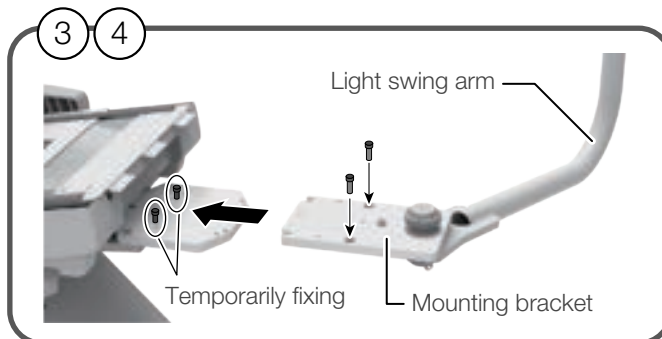

## STEP3 : Attach the light to the swing arm.

- ⑤ Loosen the hex socket set screw (1 piece).
- ⑥ Feed the light lead cable through the light post and pull the end of the lead cable from side of the swing arm.
- ⑦ Mount the light pole onto swing arm.
- ⑧ Adjust the brake with the hex socket set screw loosened in the ⑤.

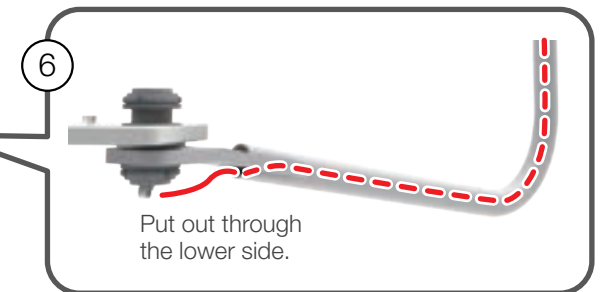
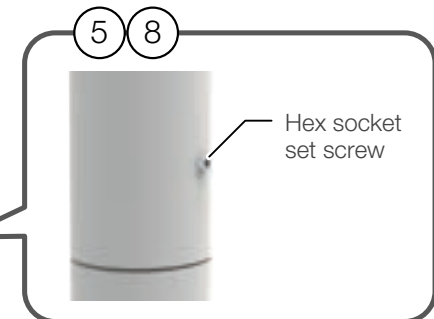

# X-CALIBUR UNIT MOUNT (Swing Arm Mount) [ Assembly procedure for installation ]

(AL-D249W-X)

## STEP4 : Attach the switch box.

- ① Attach the switch box to the light pole bracket with truss screws (4 pcs.).

## STEP5 : Connect the wirings in the switch box.

- ② Connect the connectors from connection cable and lead wire from the light as shown in the figure.

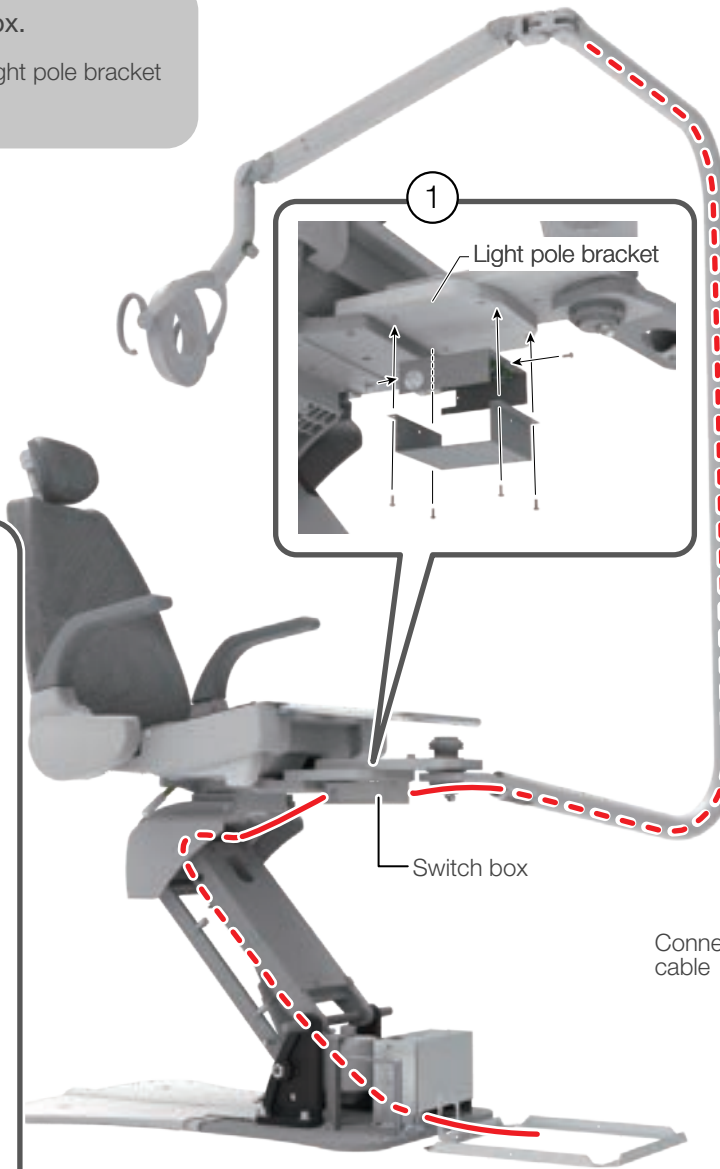
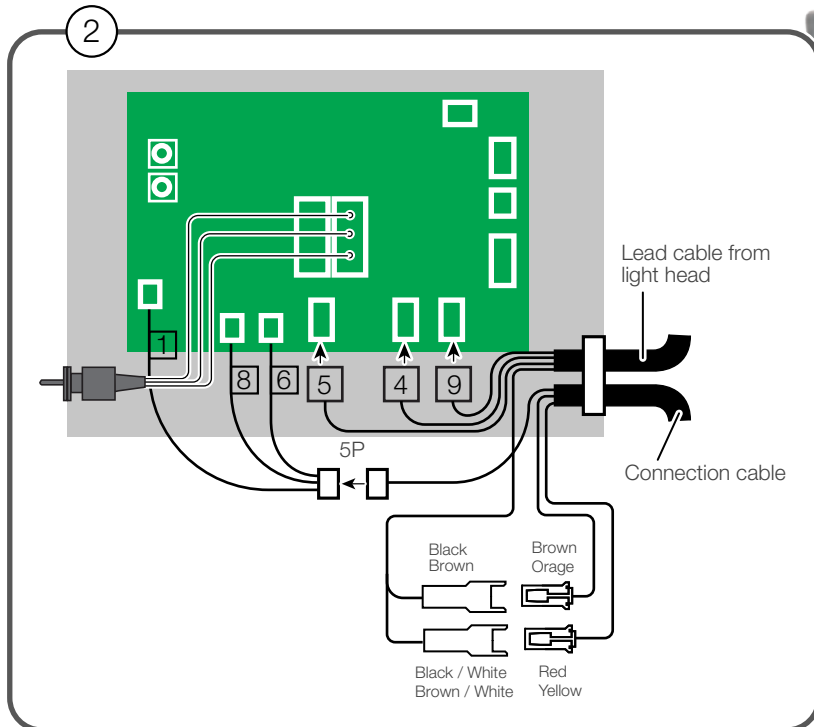

## STEP6 : Attach the power supply box.

- ③ Attach the power supply box to the junction unit.
- ④ Pass the connection cable through the chair and to the junction unit.
- ⑤ Connect the connector from the power supply box to connection cable from switch box.
- ⑥ Pipe the air supply in the junction unit.

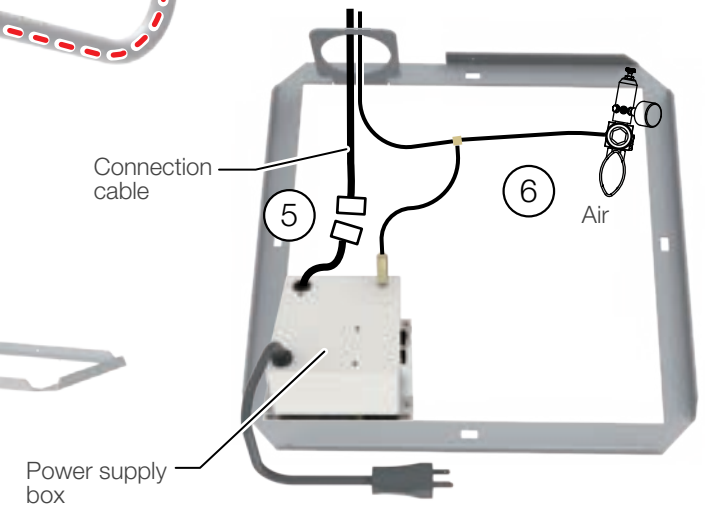

## Adjusting the parts

Left/right rotation switching procedure of the balance arm

- ① Remove the joint cover (1 flat head screw).
- ② Remove the arm rotation restriction plate (2 pan head screws).
- ③ Remove the film from the arm rotation restriction plate (2 screws).
- ④ Turn over the arm rotation restriction plate and attach the film (2 screws).
- ⑤ Attach the arm rotation restriction plate with film to the joint part.
- ⑥ Attach the joint cover.

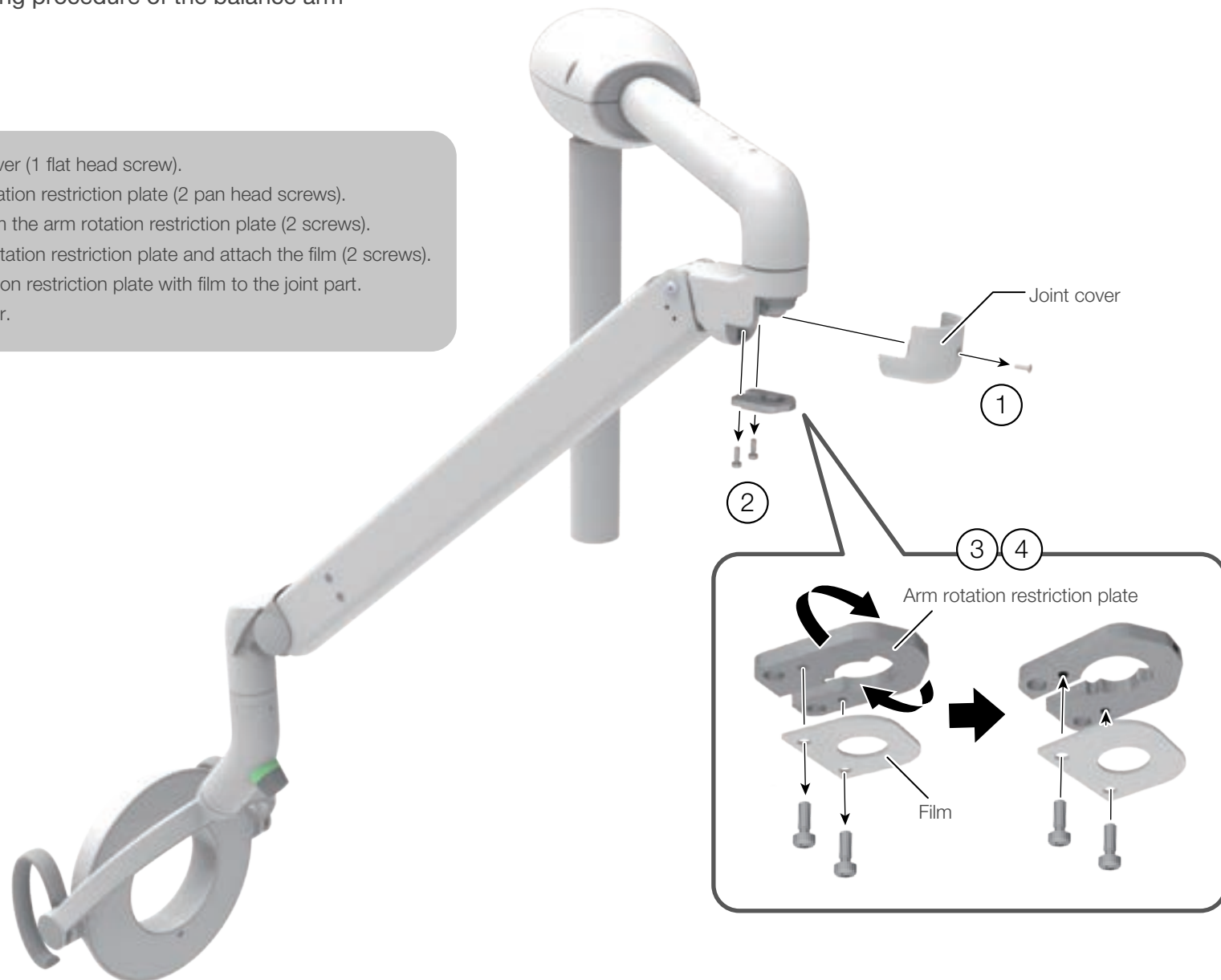

## Adjusting the parts

### Adjustment of the tension of the balance arm

- ① Position the angle of the balance arm so the tension adjustment nut becomes visible just under slot A.
- ② Turn the nut and adjust the tension with the adjustment bar supplied with the light.

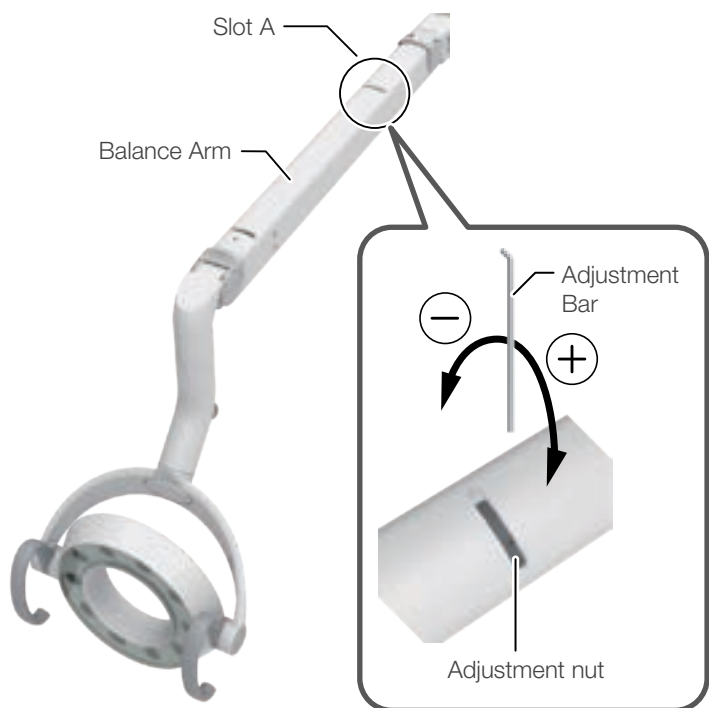

When the light head tends to go up  
→ turn the nut to ⊕ direction.

When the light head tends to go down  
→ turn the nut to ⊖ direction.

### Adjustment of the angle of the light head

- ① Use a 2mm hex key wrench to loosen hex socket set screw in front of Hole B.
- ② Position the angle of the balance arm so the tension adjustment nut becomes visible just under slot B.
- ③ Turn the nut and adjust the tension with the adjustment bar supplied with the light.

Rotating the adjustment nut without loosening the hex socket set screw may lead to the damage.

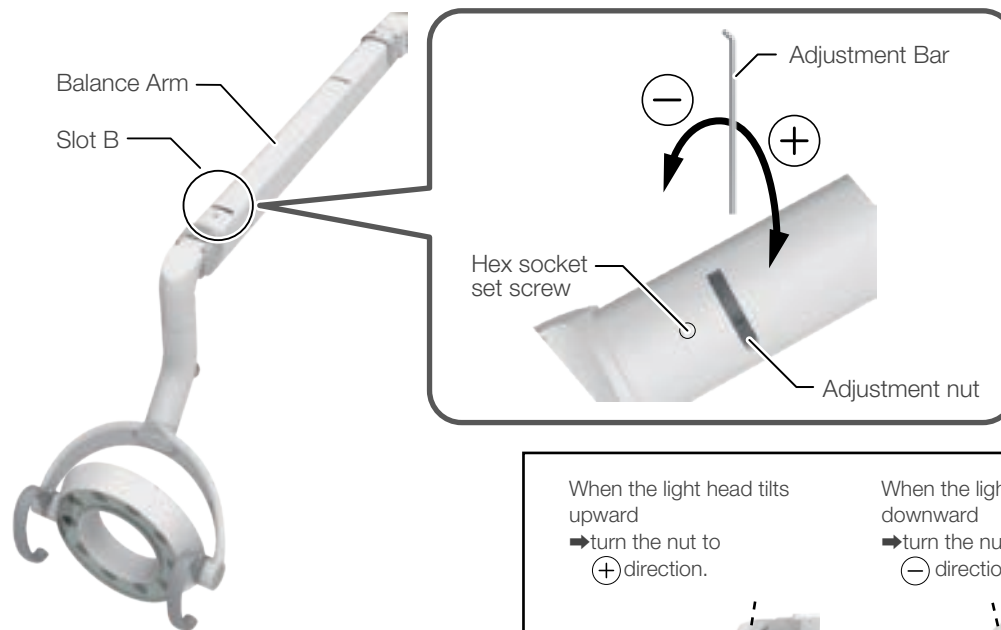

When the light head tilts upward  
→ turn the nut to ⊕ direction.



When the light head tilts downward  
→ turn the nut to ⊖ direction.

- ④ After adjustment is done, re-tighten the hex socket set screw.

Unless this hex socket set screw is re-tightened, the angle of the head will be changed during use.

# Attaching the patient mirror

## Supplied parts

No.	Part name		QTY.
1	Back cover		1
2	Patient mirror		1
3	Pan head screw M4 x 10		4

- ① Remove the pan head screw (1 pc.) and remove the rear cover of the light head.
- ② Attach the rear cover (with holes) supplied together in the patient mirror with the reverse order of ① using the pan head screw (1 piece) removed in the ①.
- ③ Attach the patient mirror.  
When viewed from behind, ensure that a curved washer comes at the right side of the mirror. Then fix it with the pan head screws M4x10, white (4pieces).

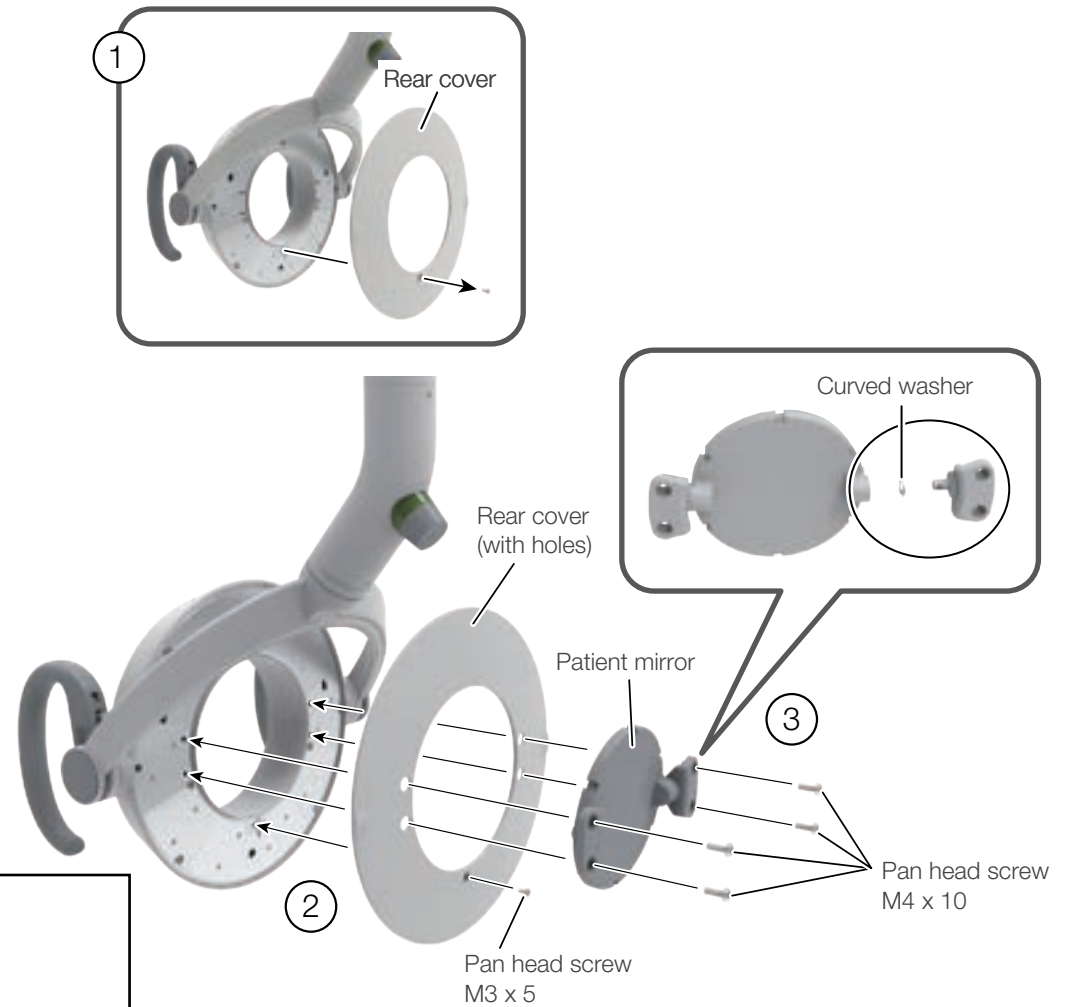

\*If the rotation of the mirror is too loose, tighten the screws further while pressing the both mirror brackets.

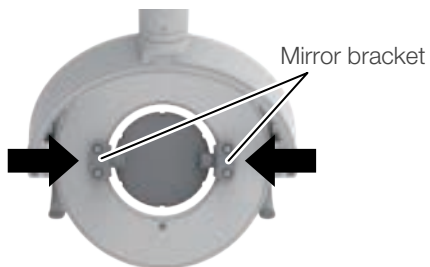

\*After the attachment is completed, make sure that the mirror can be tilted and held at around 5° as shown in the figure.

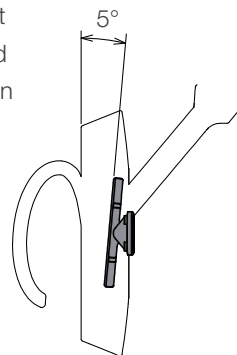

- ④ Confirm the raising/lowering balance of the balance arm.  
Make sure the light head stops at each position in the range of raising/lowering operation of the balance arm.  
If the light head doesn't stop, refer to the "Adjustment of the tension of the balance arm"[page 50] and adjust its balance.

# Wiring Diagram

## AL-D241G / AL-D241W

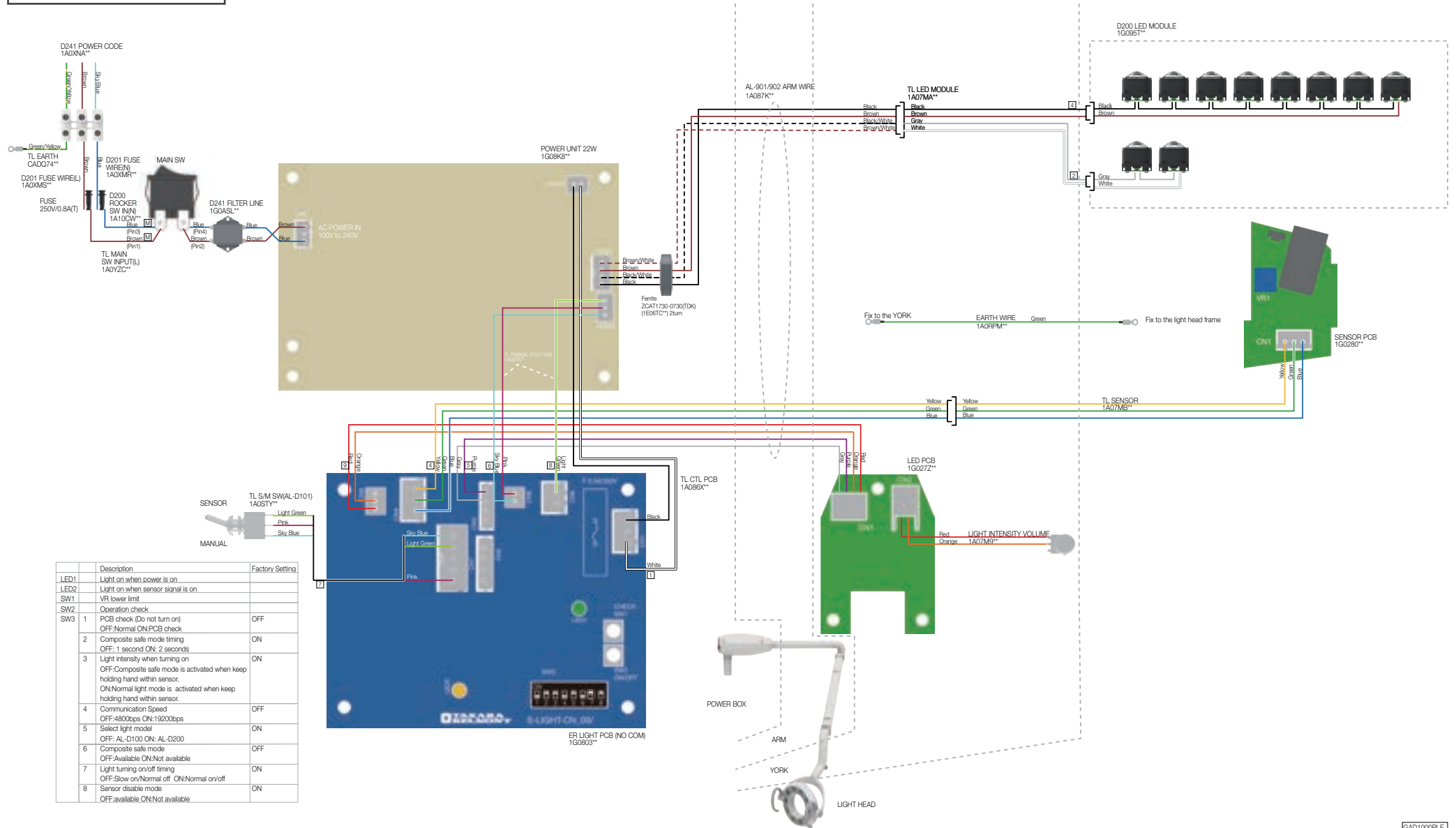

# Wiring Diagram

AL-D242G

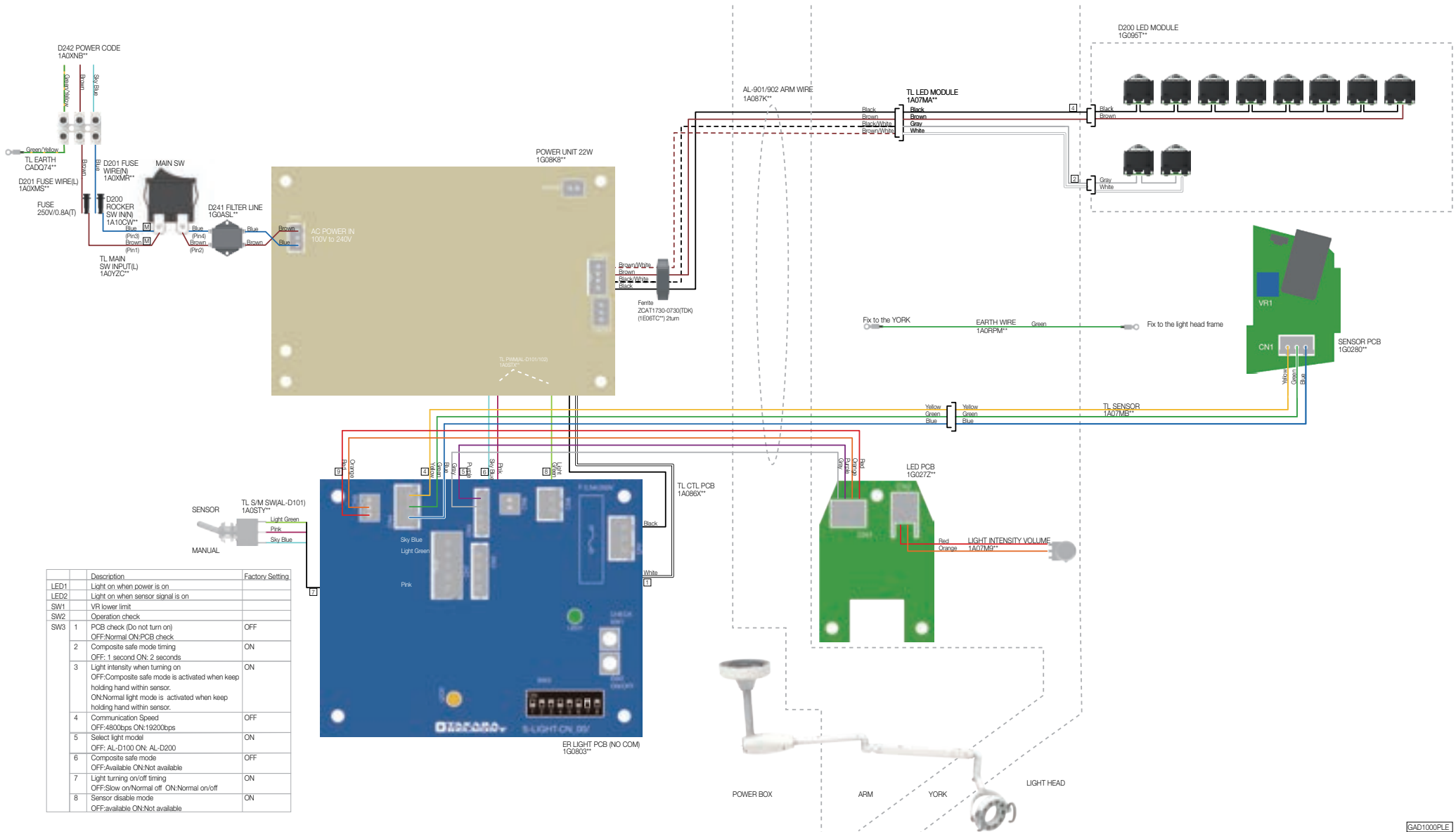

# Wiring Diagram

AL-D245G

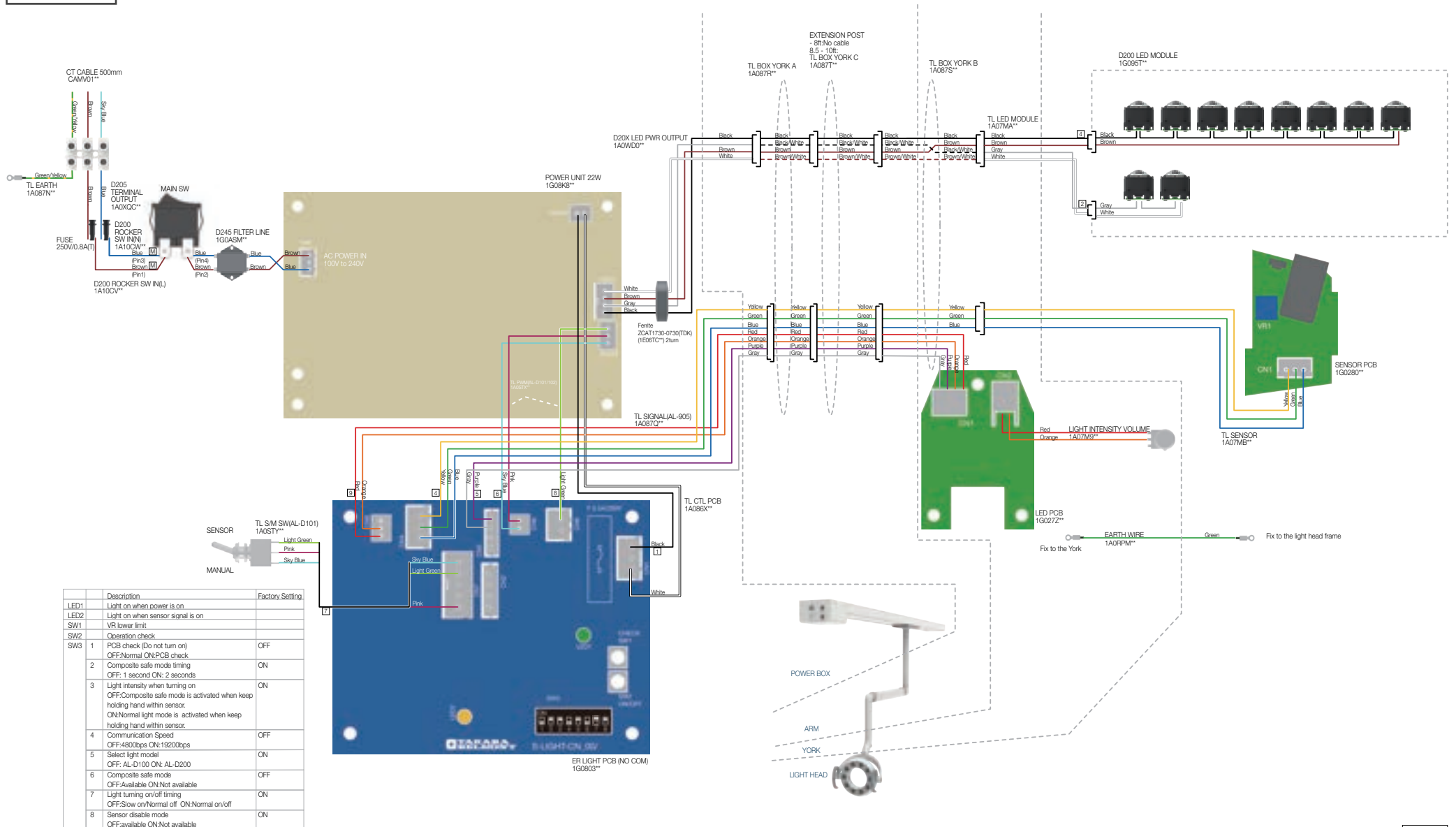

	Description	Factory Setting
LED1	Light on when power is on	
LED2	Light on when sensor signal is on	
SW1	VL lower limit	
SW2	Operation check	
SW3	1 PCB check (Do not turn on) OFF:Normal ON:PCB check	OFF
	2 Composite safe mode timing OFF: 1 second ON: 2 seconds	ON
	3 Light intensity when turning on OFF:Composite safe mode is activated when keep holding hand within sensor. ON:Normal light mode is activated when keep holding hand within sensor.	ON
4	Communication Speed OFF:4800bps ON:19200bps	OFF
	5 Select light model OFF: AL-D100 ON: AL-D200	ON
6	Composite safe mode OFF:Available ON:Not available	OFF
7	Light turning on/off timing OFF:Slow on/Normal off ON:Normal on/off	ON
	8 Sensor disable mode OFF:available ON:Not available	ON

GAD1000PQF

# Wiring Diagram

AL-D247G

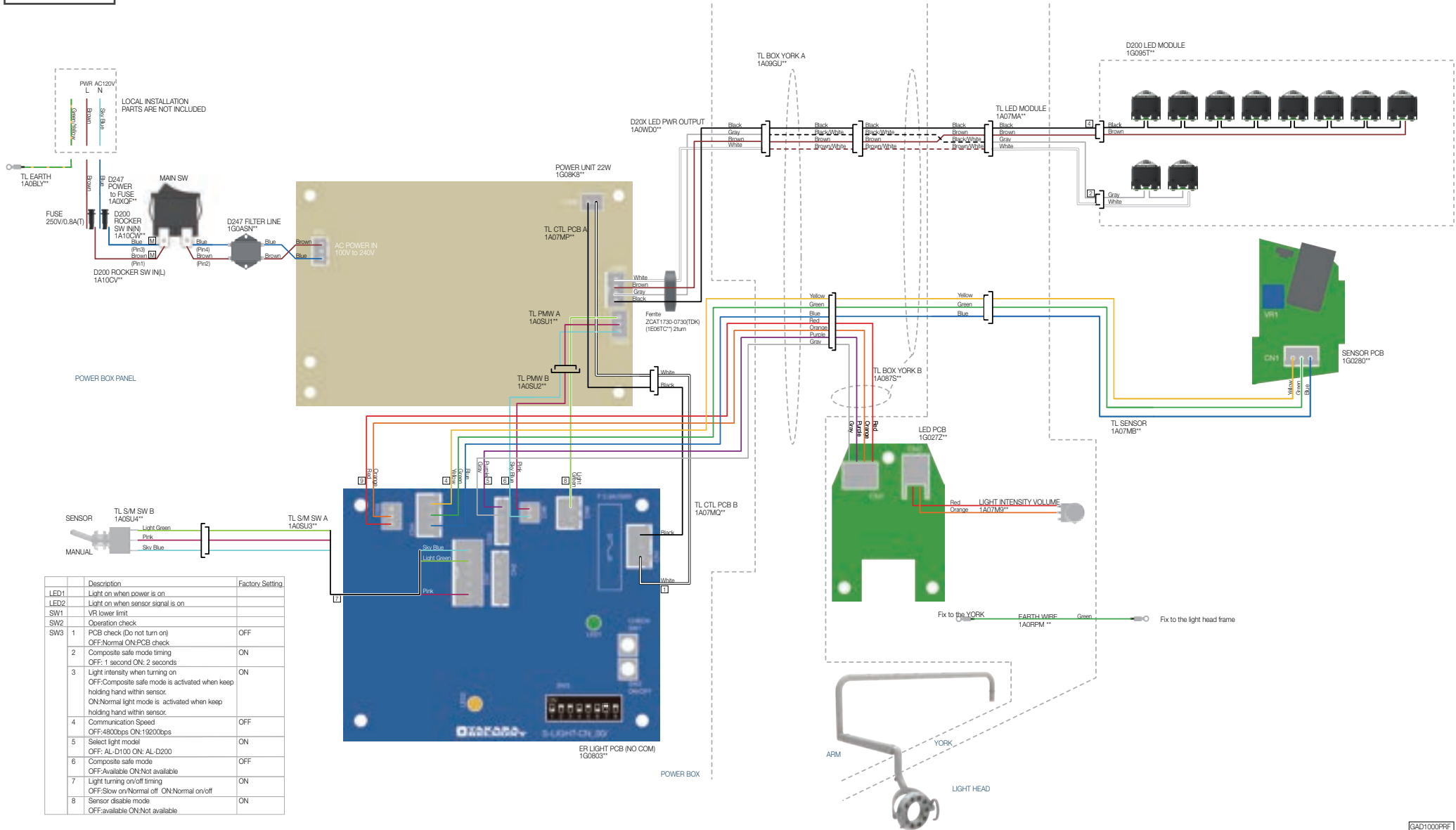

# Wiring Diagram

## AL-D248G

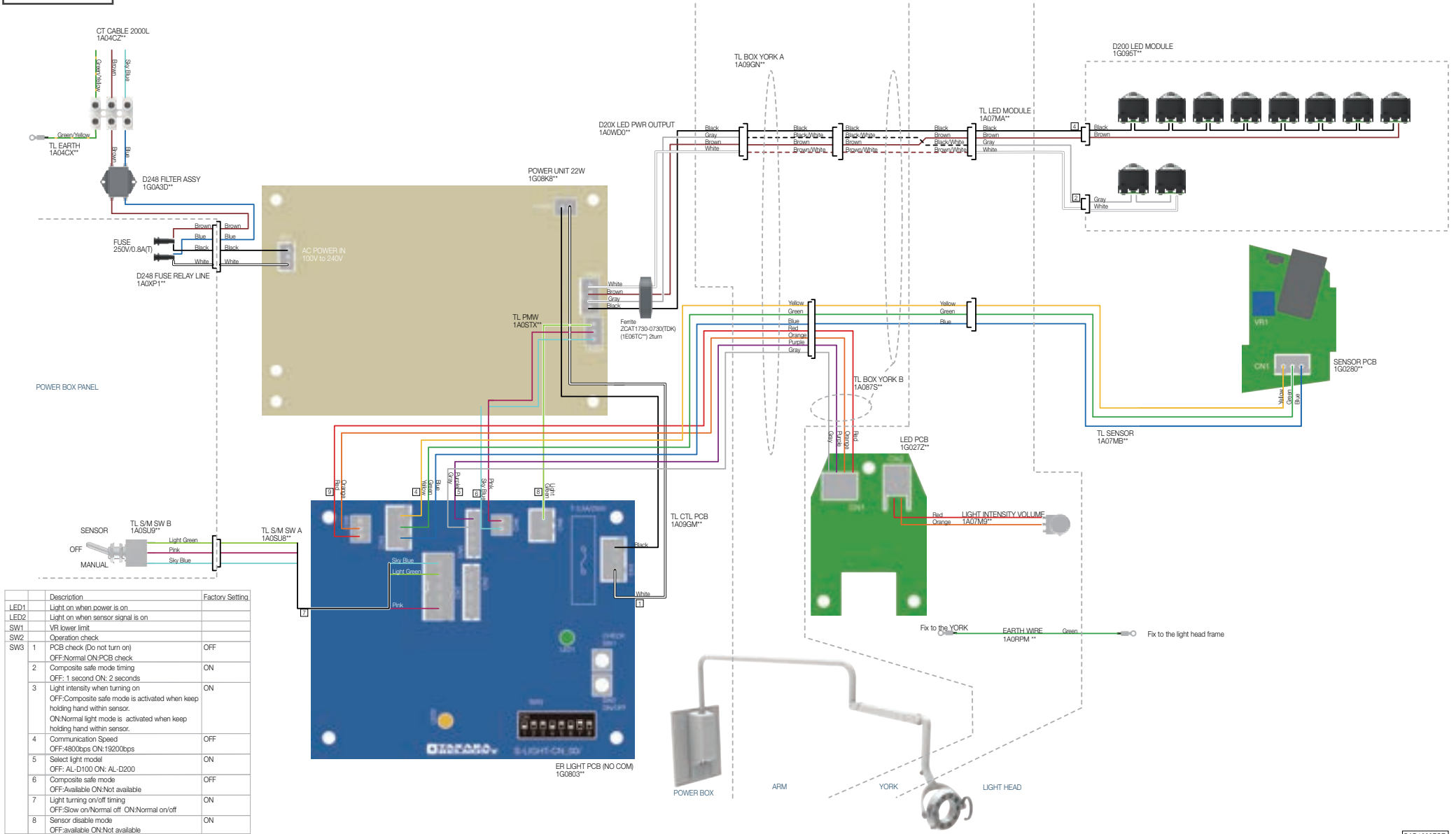



# Wiring Diagram

AL-D246G-EV / AL-D249W-X\*  
 (EVG OTP & Swing Unit on Q3300/Q5500  
 EVG Swing Unit on B50N  
 X-Calibur OTP & Swing Unit on B50N/Q3300/Q5500)

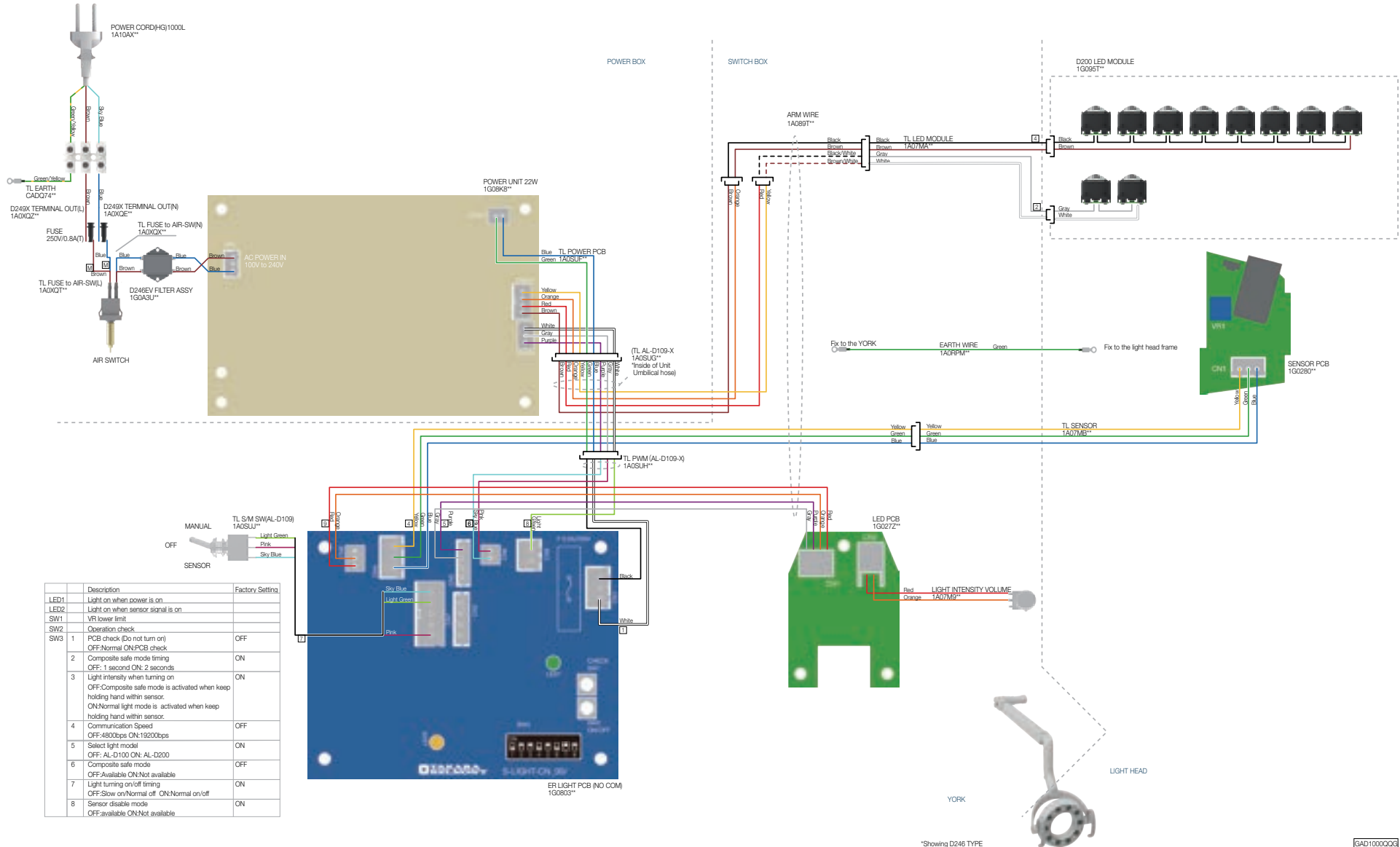

\*Showing D246 TYPE

GAD1000006

# Wiring Diagram

## AL-D246G-EV (EVG OTP Unit on B50N only)

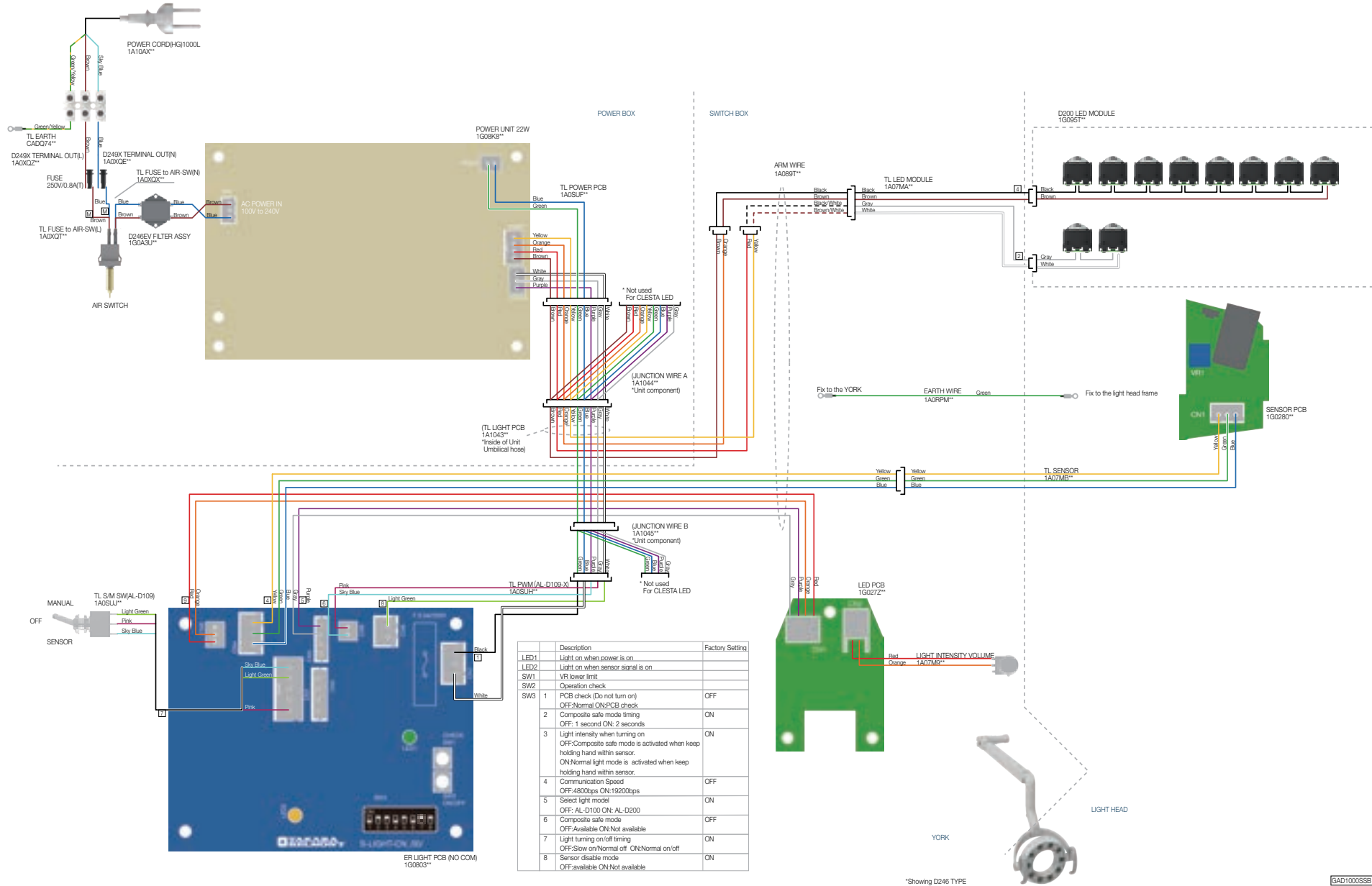

SAD1000SSB

2024-09 (8th edition)	
REF	1E08R8HE



Importer in U.S.A.  
**BELMONT EQUIPMENT,**  
Division of Takara Belmont USA, Inc.

101 Belmont Drive, Somerset, New Jersey 08873 U.S.A.

TEL : (732) 469-5000 / (800) 223-1192

FAX : (732) 356-1035

Importer in Canada

**TAKARA COMPANY, CANADA, LTD.**

2455 Meadowvale Blvd. Mississauga, Ontario L5N 5S2, Canada

TEL : (905) 816-8965

[www.belmont.ca](http://www.belmont.ca)

**TAKARA BELMONT CORPORATION**

2-1-1, Higashishinsaibashi, Chuo-ku, Osaka, 542-0083, Japan

TEL : +81-6-6213-5945

FAX : +81-6-6212-3680

