

Bel-Nova
INSTALLATION INSTRUCTIONS

Mount type

AL-D101G / AL-D101W (POST MOUNT)



AL-D102G (CEILING MOUNT)



AL-D105G (TRACK MOUNT)



AL-D106G (UNIT MOUNT)



AL-D109W (UNIT MOUNT)



AL-D107G (CABINET MOUNT)



AL-D108G (WALL MOUNT)



| | |
|---|----|
| Mount type | 2 |
| 1 Cautions regarding installation | |
| 1-1 Precautions for installation | 4 |
| 2 Specifications of the Product | |
| 2-1 Intended Use of the Product | 6 |
| 2-2 Technical Data | 7 |
| 2-3 Major Components | 12 |
| 3 Installation | |
| 3-1 Supplied parts | 16 |
| 3-2 Assembly procedure for installation | 16 |
| 3-2-1 AL-D101G / AL-D101W | 16 |
| 3-2-2 AL-D102G | 19 |
| 3-2-3 AL-D105G | 25 |
| 3-2-4 AL-D106G-QU | 31 |
| 3-2-5 AL-D106G-EV / AL-D109W-X / AL-D109W-XN | 43 |
| 3-2-6 AL-D107G | 51 |
| 3-2-7 AL-D108G | 53 |
| 3-3 Attaching the patient mirror | 58 |
| 3-4 Confirmation guideline following installation | 59 |
| 4 Adjusting the parts | |
| 4-1 Adjusting the upper limit position of the balance arm | 60 |
| 4-2 Adjusting the raising/lowering stiffness of the balance arm | 61 |
| 4-3 Adjusting the raising/lowering balance of the balance arm | 62 |
| 4-4 Adjusting the turning stiffness of the balance arm | 63 |
| 5 Wiring Diagram | |
| 5-1 Wiring Diagram | 64 |

1 Cautions regarding installation

1-1 Precautions for installation

1. During lifting of the dental light, make sure to hold the place shown in the figure below. If not, it may lead to physical injury or property damage.

AL-D101G / AL-D101W



AL-D102G



AL-D106G / AL-D109W

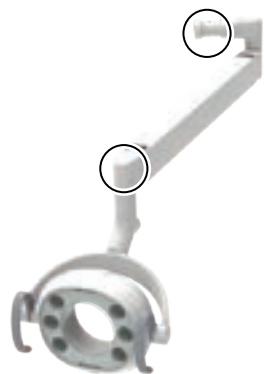

AL-D105G / AL-D107G / AL-D108G



1 Cautions regarding installation

2. Do not drop the product, let it crash into something, or apply strong impact.
3. Do not connect an input power supply other than with the rated power level.
4. Make sure to connect ground wires.
5. Have the clinic equipped with double-pole switch at the power outlet or the switchboard.
6. Adjust the levels of the unit and chair so that the light stops in the required position.
Read the installation instructions for the unit and chair concerning the level adjustment.
(AL-D106G / AL-D109W)
7. Once all work is completed, confirm that each part operates normally.

WARNING

To avoid the risk of electric shock, this equipment must only be connected to a supply mains with protective earth.
Failure or electric leak may result in electric shock.

Do not directly expose human eyes to LED light.
Exposure may hurt human eyes.

2 Specifications of the Product

2-1 Intended Use of the Product

This product is an active therapeutic device intended for the exclusive use for diagnoses, treatments and relative procedures of dentistry.

The product must be operated or handled by the qualified dentists or by dental staffs under the supervision of the dentist. Such dentists or dental staffs should instruct and/or assist the patients to approach to and leave from the product.

Patients should not be allowed to operate or handle the product unless he/she is so instructed.

2 Specifications of the Product

2-2 Technical Data

| | |
|---|--|
| Model | AL-D101G / AL-D101W / AL-D102G /AL-D105G / AL-D106G / AL-D107G / AL-D108G / AL-D109W |
| Classification by | Class I Equipment |
| type of protection against electric shock | |
| Rated voltage..... | AC100 - 240V 50 / 60Hz |
| Rated input..... | 0.30 - 0.15A |
| Fuse | 0.8A / 250V (Interrupting capacity 35A / 250VAC) |
| | Operating speed : Time lag |
| | Size : 3/16 x 13/16" (5 x 20mm) |
| Operation mode | Continuous operation |
| Weight | [AL-D101G / AL-D101W] |
| | 15.9lbs (7.2kg) |
| | [AL-D102G] |
| | 24.7lbs (11.2kg) (with 13-3/8" (340mm) pole) |
| | [AL-D105G] |
| | 35.7lbs (16.2kg) (with 15" (380mm) pole) |
| | [AL-D106G / AL-D109W] |
| | 9.3lbs (4.2kg) |
| | [AL-D107G] |
| | 26.7lbs (12.1kg) |
| | [AL-D108G] |
| | 47.8lbs (21.7kg) |
| Light source | 6 LED lamps |
| Optical performance | Standard irradiation distance: 25-19/32" (650 mm) |
| | In treatment mode |
| | Central illuminance: 460 - 3160fc (5000–34000 lx) |
| | Correlated color temperature: 5000 K |
| | In Composite Safe mode |
| | (Compliant with ISO 9680: 2014 5.2.10) |
| | Central illuminance: 1020fc (11000 lx) |
| | Correlated color temperature: 2,700 K |
| Illuminance pattern | Pattern dimensions (length x width): 3-3/8 x 6-1/8" (85 x 155 mm) |

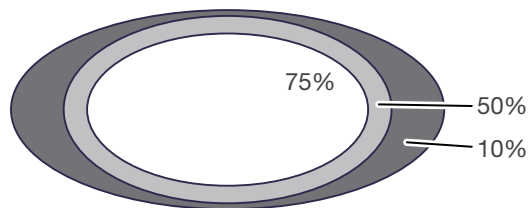

75%/50%/10%: 75%/50%/10% areas of maximum illuminance

| | |
|---|--|
| Environment for use | Temperature: 32 - 104°F (0-40°C) |
| | Humidity: 10 - 95% (No condensation) |
| | Atmospheric pressure: 10.2 - 15.4psi (700 - 1,060 hPa) |
| Environment for transport and storage | Temperature: -4 - 158°F (-20 - 70°C) |
| | Humidity: 10 - 95% (No condensation) |
| | Atmospheric pressure: 10.2 - 15.4psi (700-1,060 hPa) |
| Adaptability to high oxygen-level environment | Not for use in a high oxygen-level environment |

Refer to the rating plate for the capacity of power supply.

The specification is subject to change without notice.

2 Specifications of the Product

AL-D101G / AL-D101W

Unit : inch (mm)
Tolerance in dimensions: $\pm 10\%$

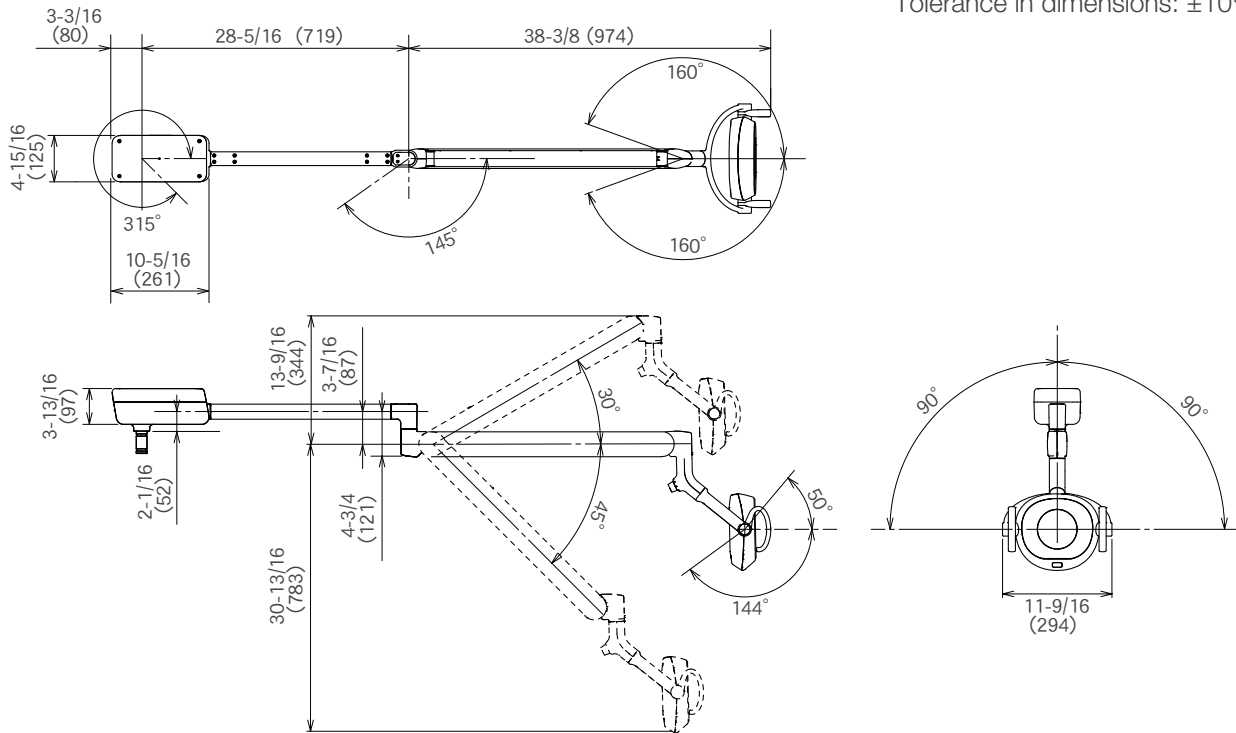

AL-D102G

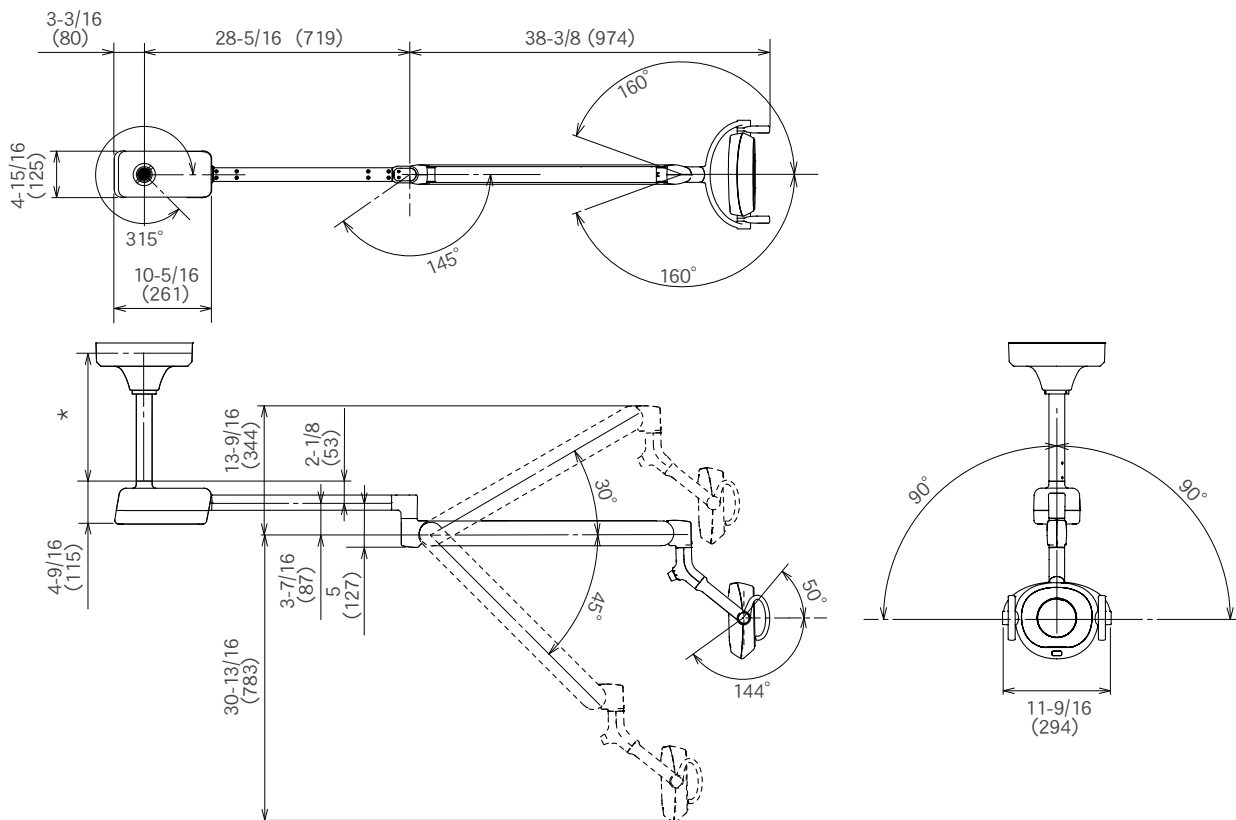

*Select suspension tube length based upon ceiling height.

The specification is subject to change without notice.

2 Specifications of the Product

AL-D105G

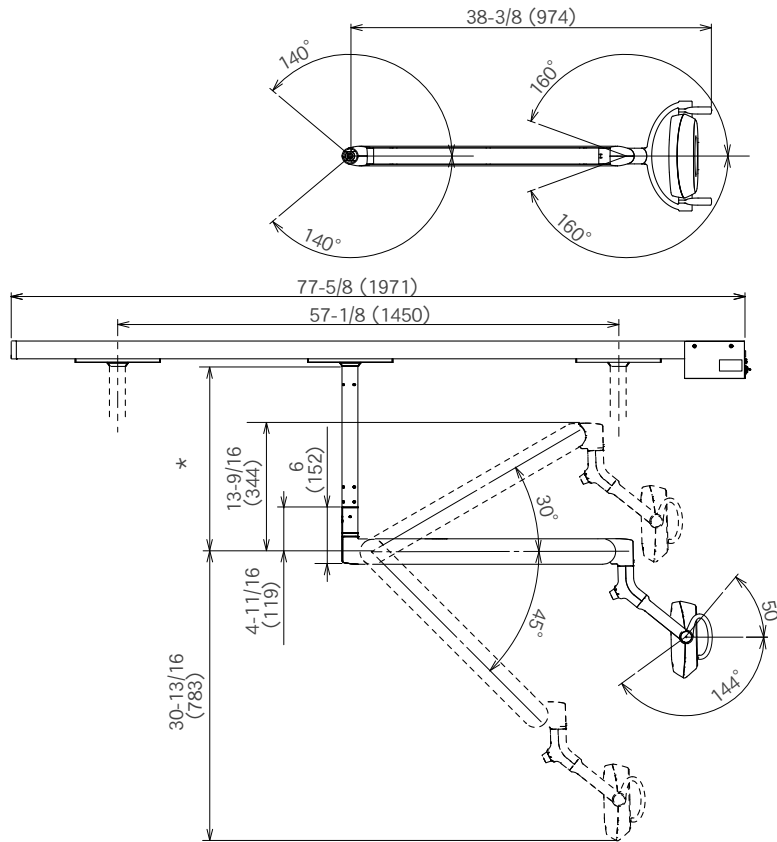

Unit : inch (mm)
Tolerance in dimensions: $\pm 10\%$

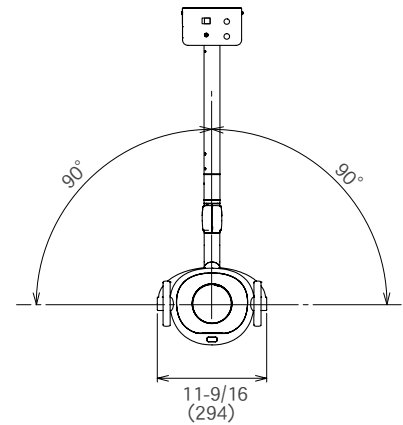

*Select suspension tube length based upon ceiling height.

AL-D106G

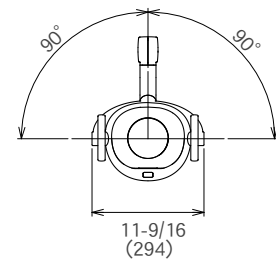
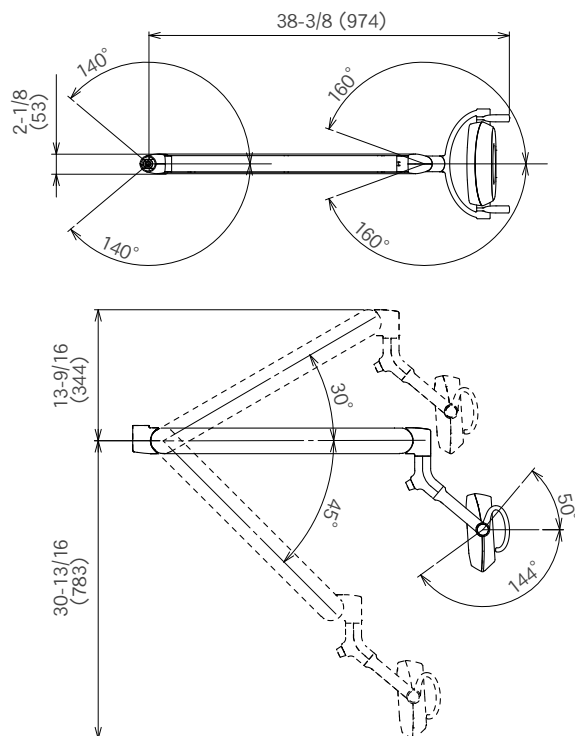

The specification is subject to change without notice.

2 Specifications of the Product

AL-D109W

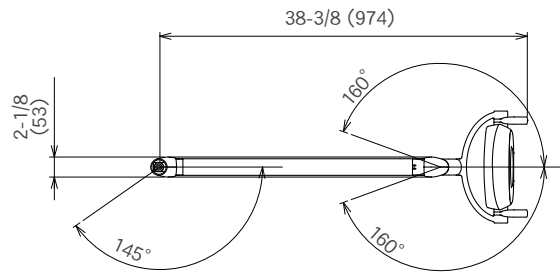

Unit : inch (mm)
Tolerance in dimensions: $\pm 10\%$

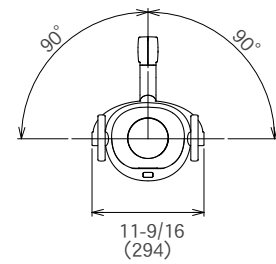
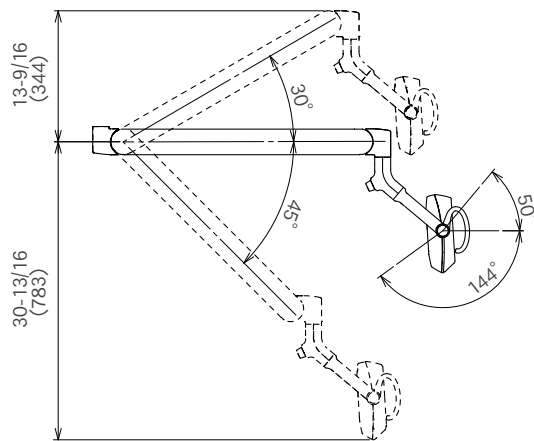

AL-D107G

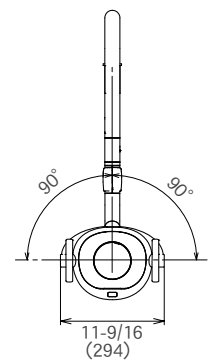
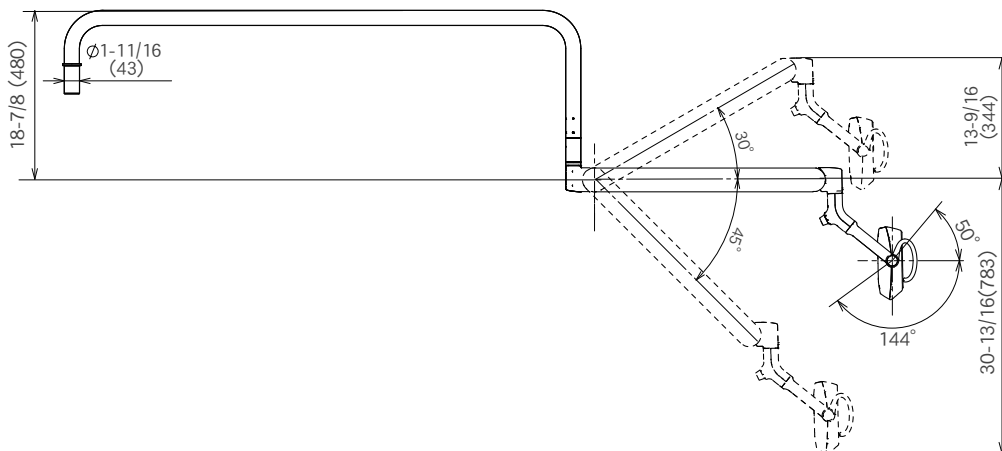
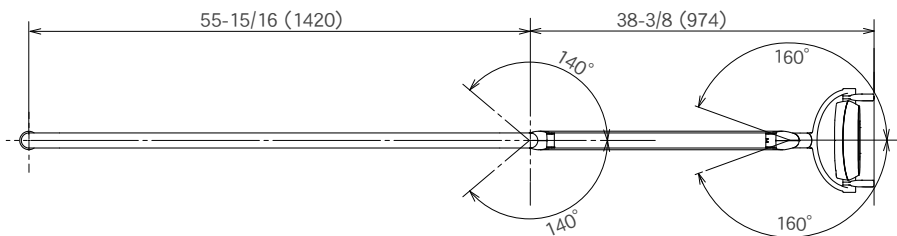

The specification is subject to change without notice.

2 Specifications of the Product

AL-D108G

Unit : inch (mm)
Tolerance in dimensions: $\pm 10\%$

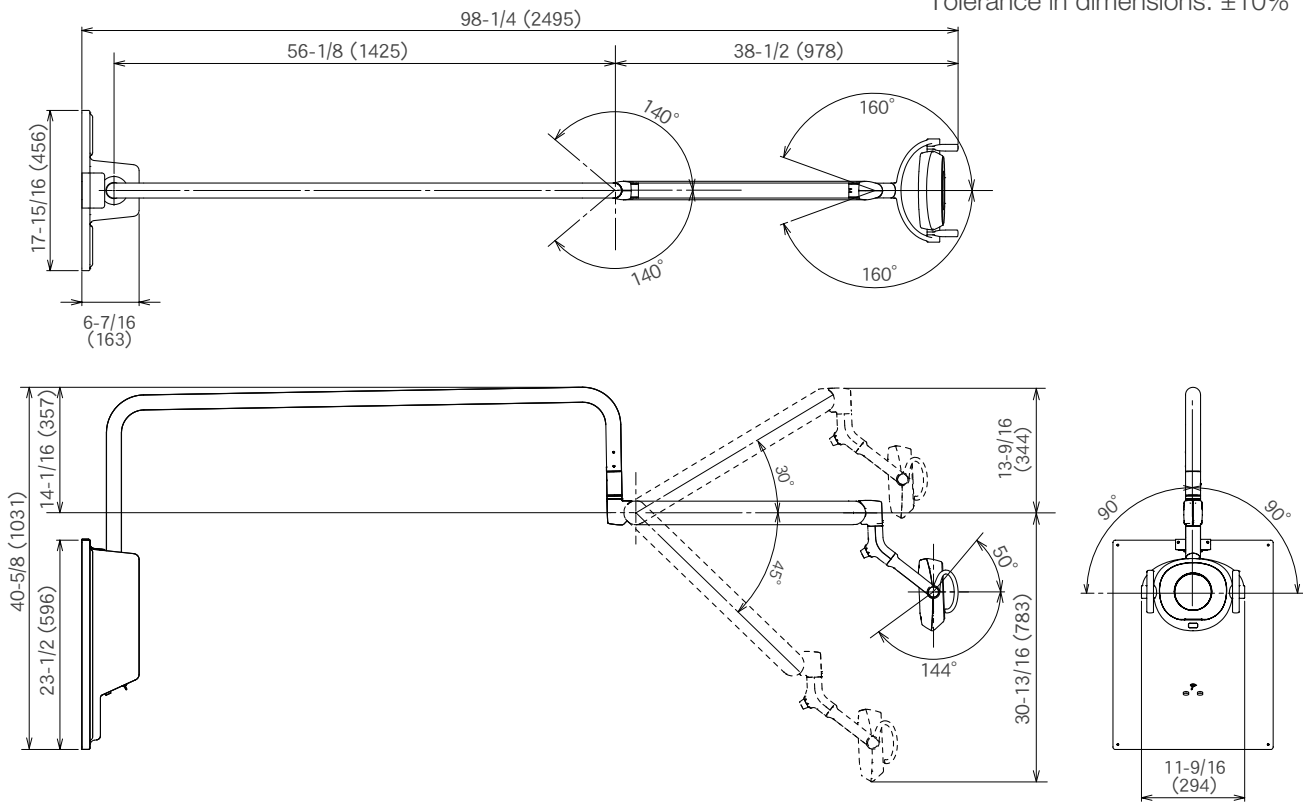

The specification is subject to change without notice.

2 Specifications of the Product

2-3 Major Components

AL-D101G / AL-D101W

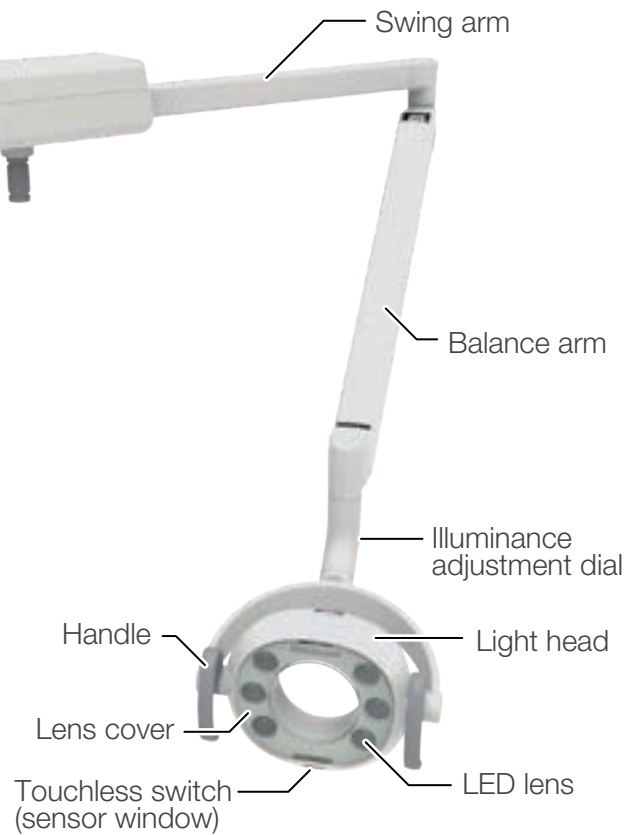
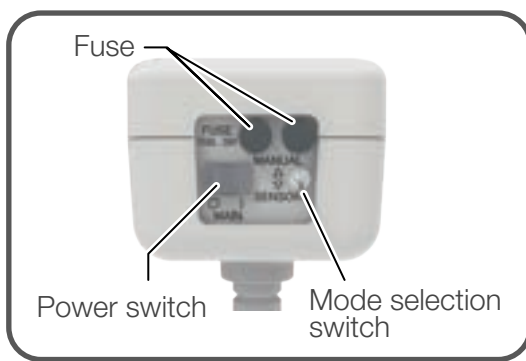

AL-D102G

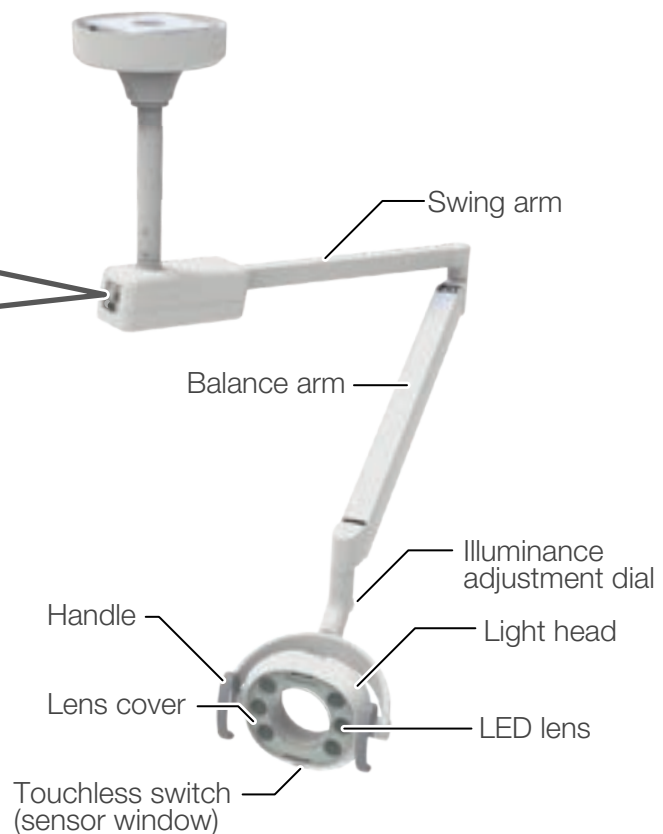
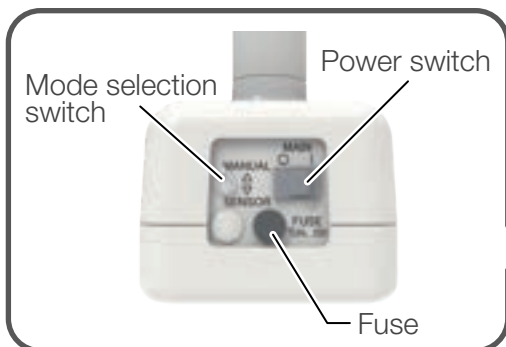

2 Specifications of the Product

AL-D105G

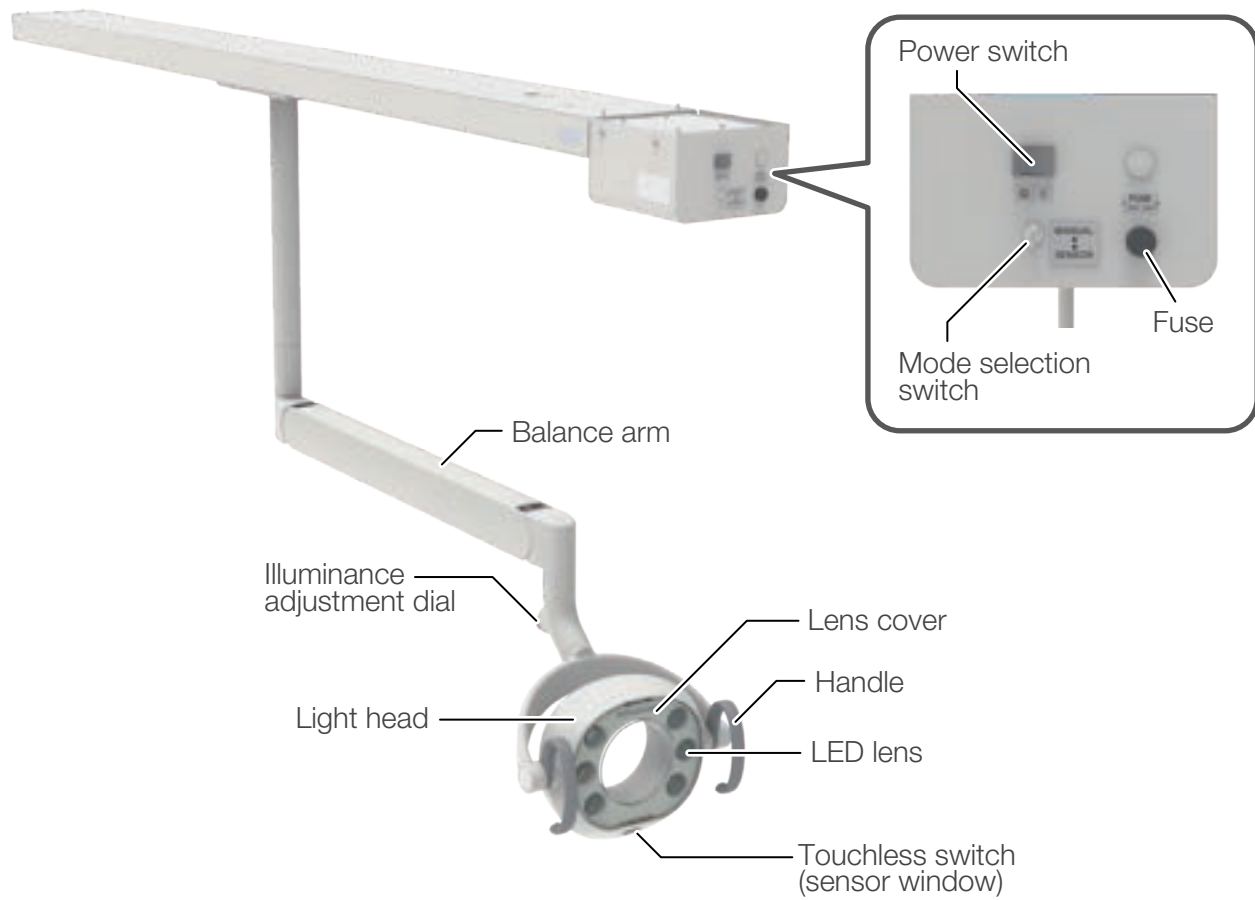

AL-D106G

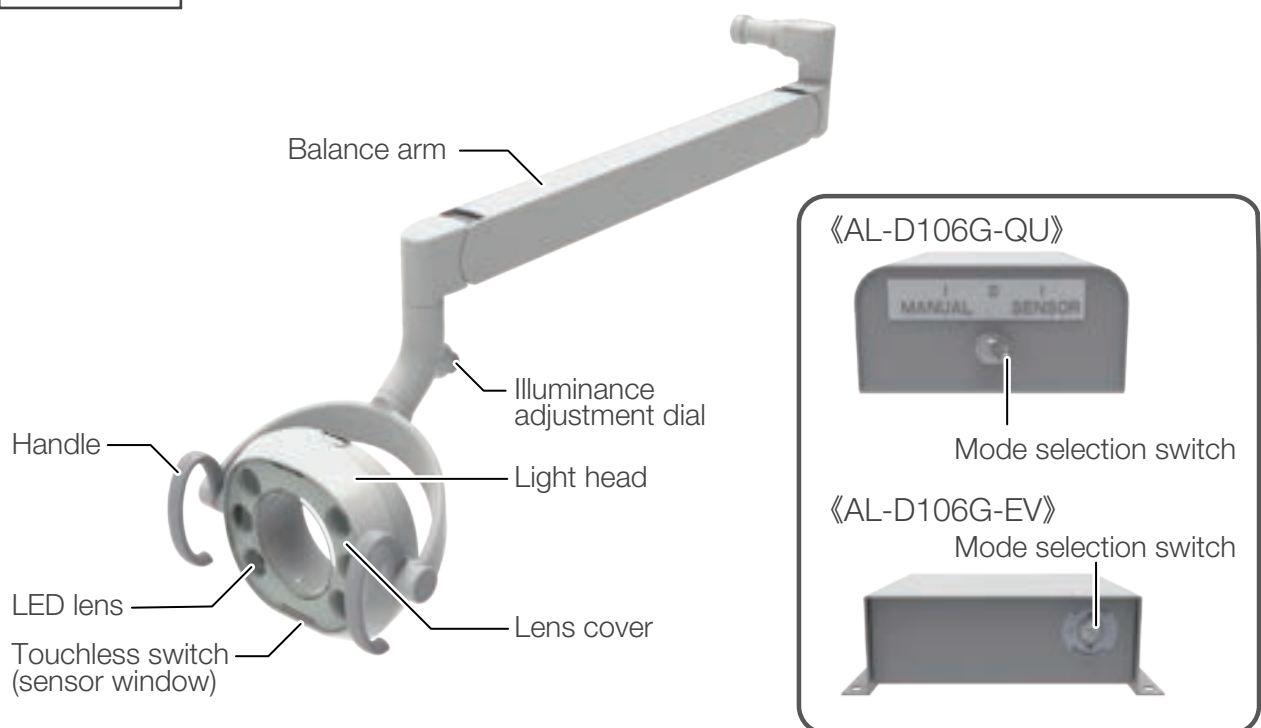

2 Specifications of the Product

AL-D109W

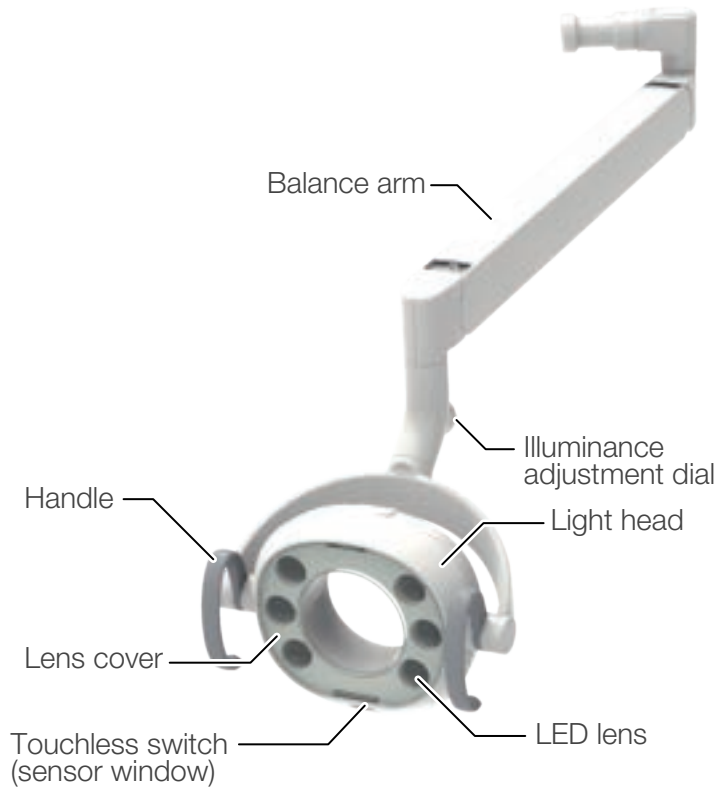

《AL-D109W-X》

Mode selection switch



《AL-D109W-XN》

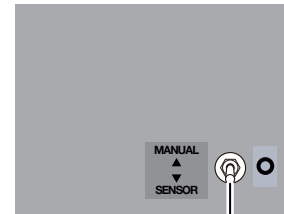

Mode selection switch

AL-D107G

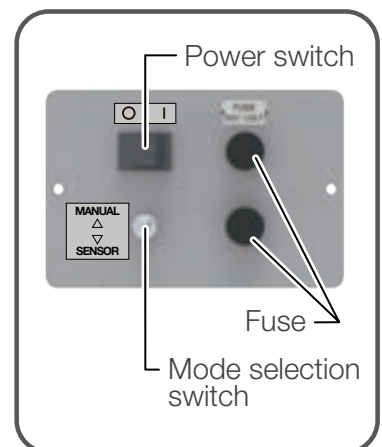
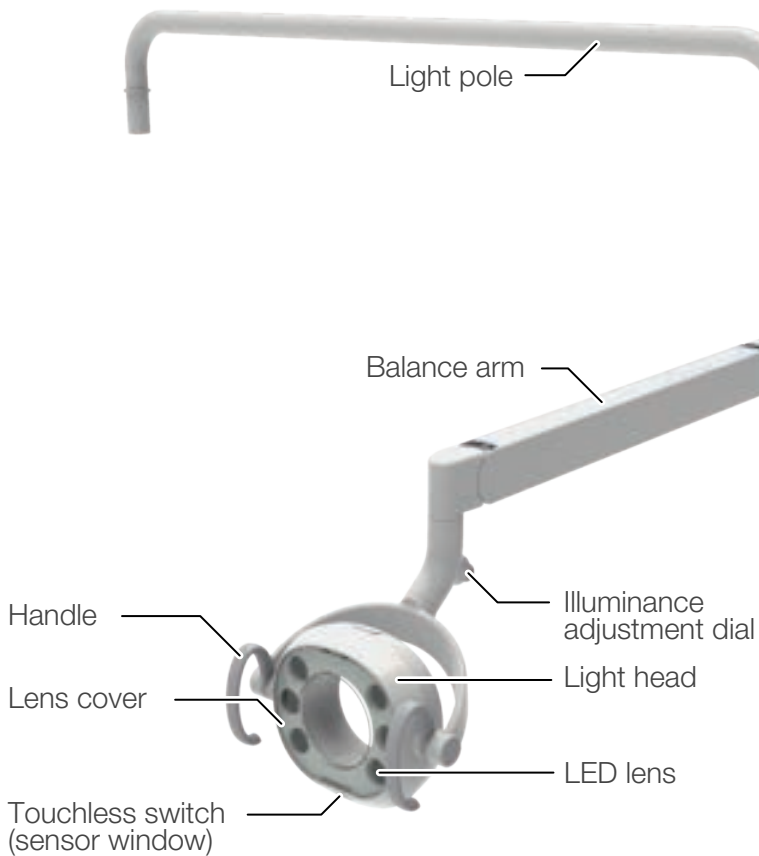

2 Specifications of the Product

AL-D108G

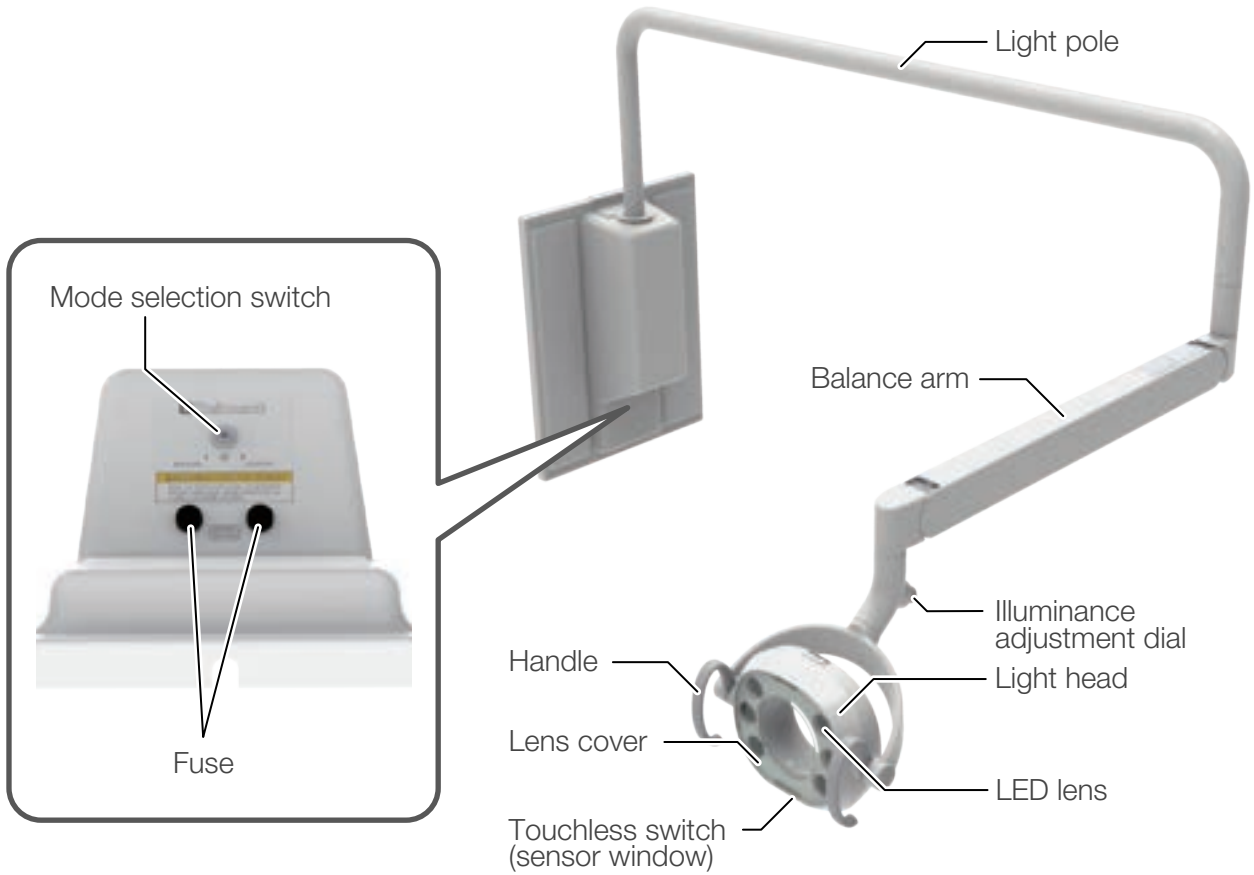

3 Installation

3-1 Supplied parts

| No. | Part name | QTY. |
|-----|----------------|------|
| 1 | Adjustment rod | 1 |

* Use of the adjustment rod is shown on pages 60 to 61.

3-2 Assembly procedure for installation

3-2-1 AL-D101G / AL-D101W

Necessary tools

Phillips screwdriver No. 1, 2

Hex key wrench; width across flats: 2 mm / 2.5mm / 4mm)

(1) Attach the balance arm to the swing arm

1. Detach the cover of the power supply box.

Remove the four pan head screws (M4 x 8, plated).

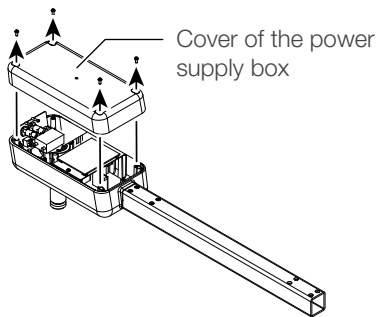

2. Detach the swing arm.

Remove the two countersunk screws (M4 x 10, plated) and remove the swing arm from the power supply box.

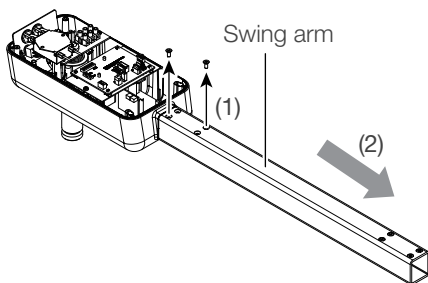

3. Pass the lead cable through the swing arm and power supply box.

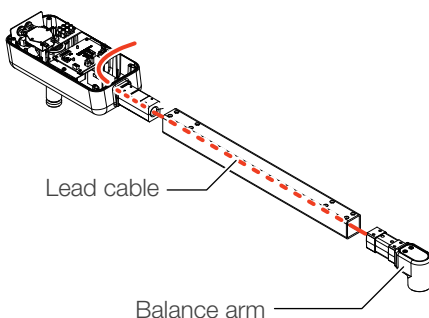

3 Installation

4. Connect the connector of the lead cable to the light control PCB and light power PCB in the power supply box.

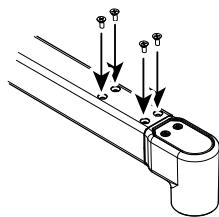
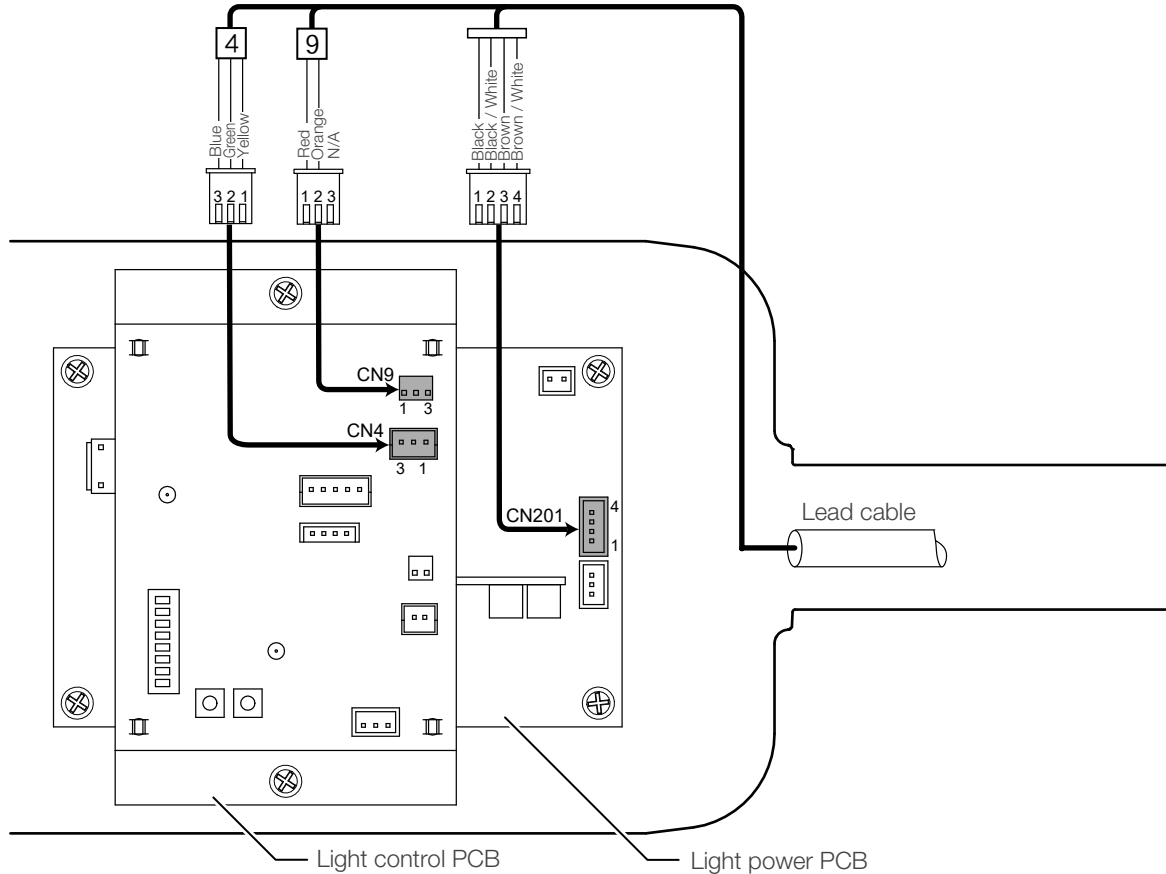

5. Insert the balance arm joint into the swing arm and fix it with four countersunk screws (M4 x 10, plated).

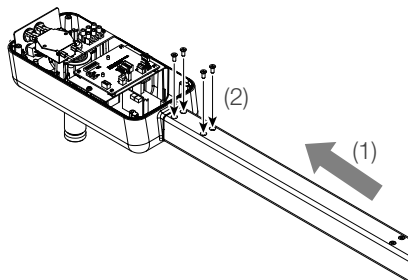

6. Insert the swing arm into the power supply box and fix it with four countersunk screws (M4 x 10, plated).

7. Reattach the cover of the power supply box in the reverse order of Step 1.

3 Installation

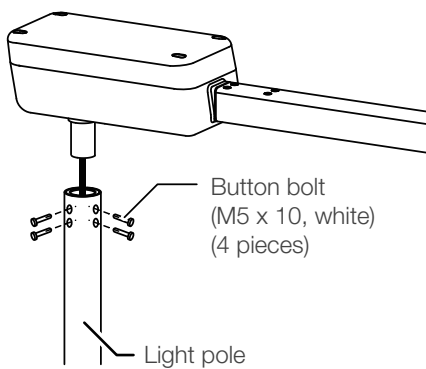
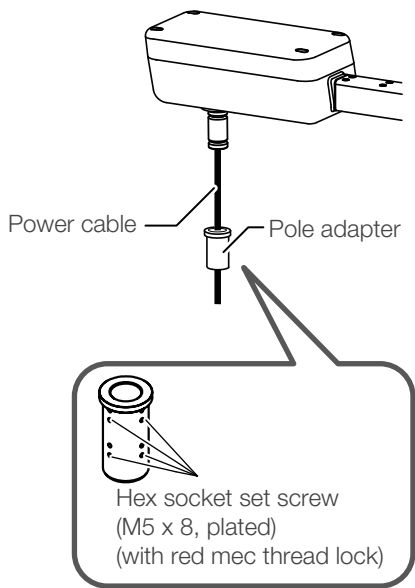

(2) Attach the light assembly to the light pole

1. Pass the power cable of the light through the light pole adapter.

Tighten the four hex socket set screws (M5×8, plated) (with red mec thread lock), which are attached to the pole adapter, and fix the arm assembly.

2. Pass the power cable of the light through the light pole.

3. Mount the light assembly and pole adapter onto the light pole.

Use the four button bolts (M5×10, white) to fix the arm assembly.



4. Attach the hospital grade plug to the power cable end.

This is to be installed electrician only, in accordance with the national electrical code and local electrical codes as applicable.

3 Installation

3-2-2 AL-D102G

Necessary tools

Phillips screwdriver No. 1, 2

Hex key wrench; width across flats: 2 mm / 2.5mm / 4mm)

Hammer, Socket wrench (13mm, 17mm)

Precaution for Installation

- (1) For safety in operation as well stability of the light source, the importance of proper ceiling structure can not be overemphasized. The ceiling structure capable of supporting 220lb (100kg) dead weight is requires.
- (2) Be sure request specialized electric construction person accompanied by indoor electric wiring work.

(1) Installation of Ceiling

1. Lead out the power supply cable (0.75mm² x 3 wires or more) from the ceiling.

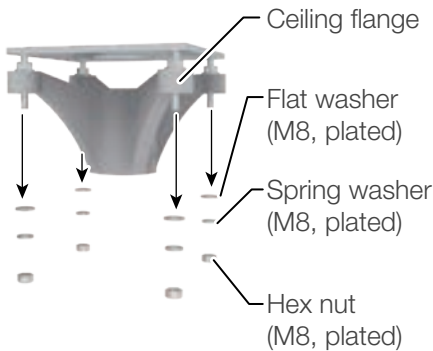

2. Remove the nuts and washers from the included ceiling flange set shown in the figure and remove the ceiling flange.

3. Pass the power supply cable pulled out in step 1 through the hole in the flange base, and fix the flange base to the ceiling.

Refer to “Flange base template” (next page) for the flange base fixing hole dimensions.

| Ceiling material | Wood | Steel Frame | Concrete |
|------------------------------------|---|---|---|
| | <p>Square timber (Hard wood more than 4-1/8" (105mm))</p> <p>Flange base</p> <p>Flat washer M10, plated</p> <p>Spring washer M10, plated</p> <p>Coach bolt M9 x 100, plated</p> | <p>Hex bolt M8 x 50, plated</p> <p>Flat washer M8, plated</p> <p>Spring washer M8, plated</p> | <p>M8 Anchor nut (Embedded)</p> <p>Flat washer M8, plated</p> <p>Spring washer M8, plated</p> <p>Hex bolt M8 x 50, plated</p> |
| Prepared hole diameter [inch (mm)] | ϕ 3/16 (5) | ϕ 3/8 (10) | M8 Embedded Anchor nut |
| Fixing bolt | Coach bolt M9 x 100, plated | Hex bolt M8 x 50, plated | Hex bolt M8 x 50, plated |

3 Installation

Flange base template

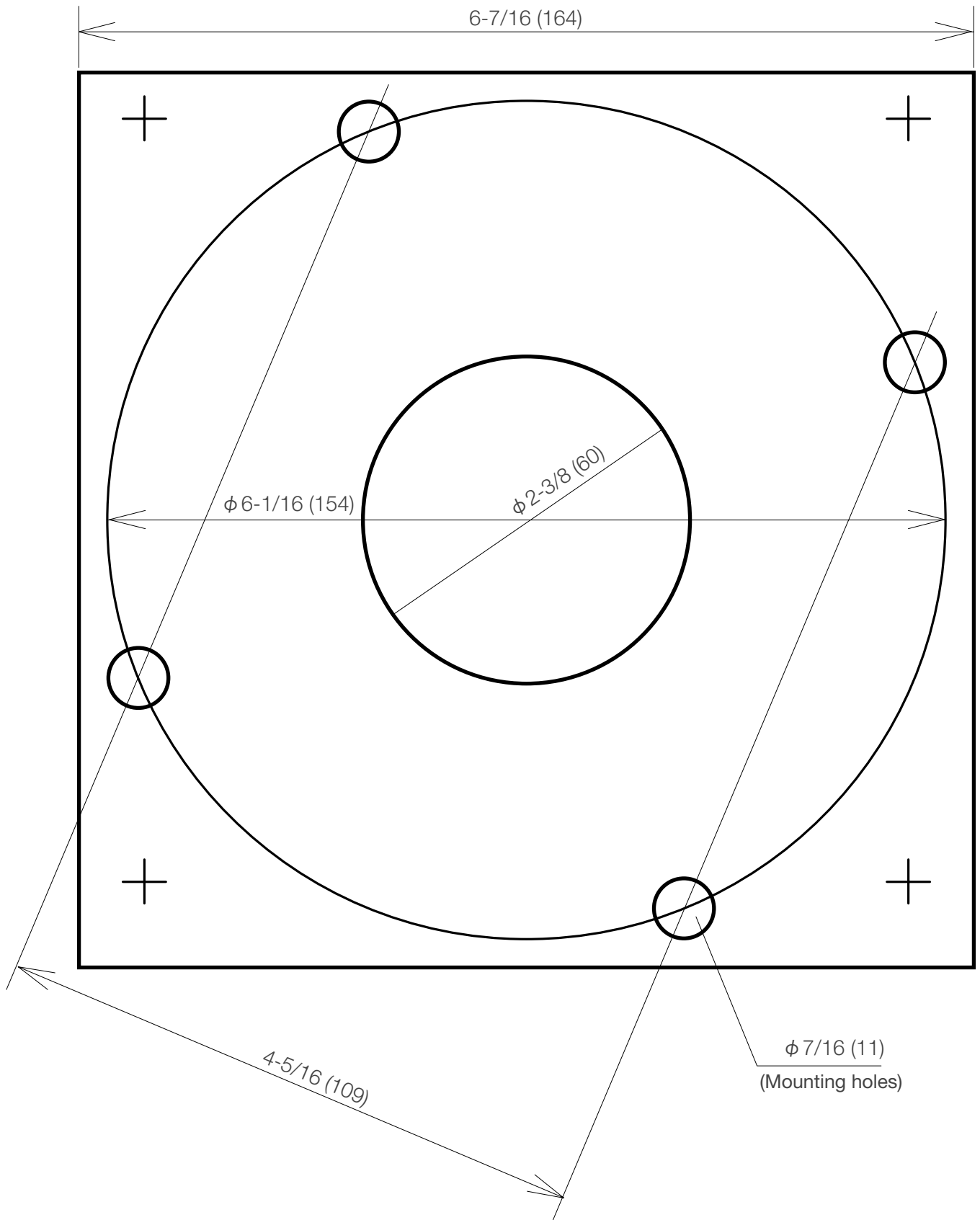

Unit : inch (mm)

3 Installation



(2) Attaching the ceiling pole to the ceiling flange

1. Attach the roll pin to the ceiling pole with hammer.

2. Insert the ceiling pole into the ceiling flange and set the roll pin to groove on the ceiling flange.

3. Fix it with four hex socket set screws (M6 x 8, SUS).

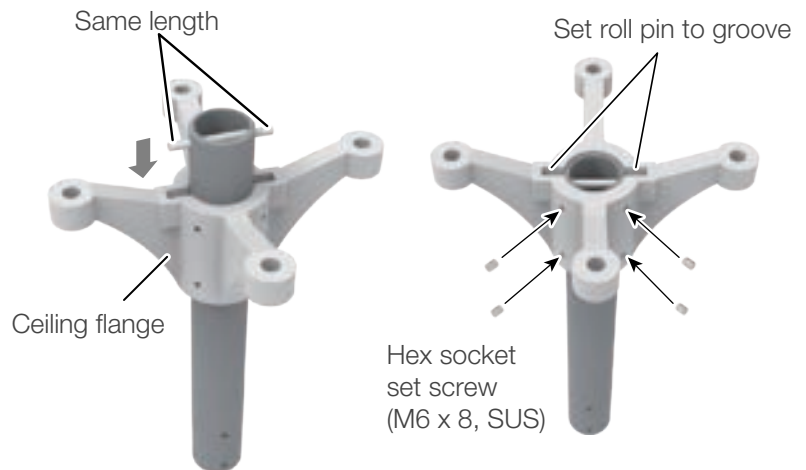

(3) Attach the balance arm to the swing arm

1. Detach the cover of the power supply box.

Remove the four pan head screws (M4 x 8, plated).

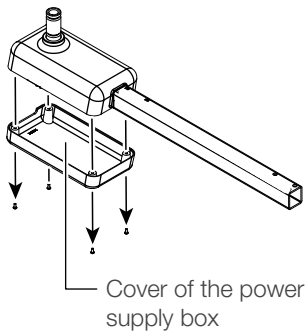

2. Detach the swing arm.

Remove the two countersunk screws (M4 x 10, plated) and remove the swing arm from the power supply box.

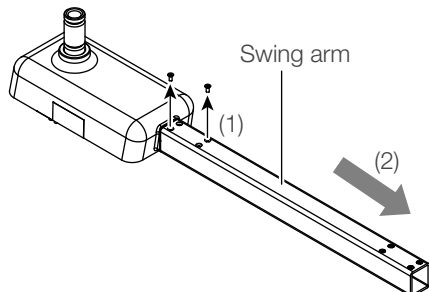

3 Installation

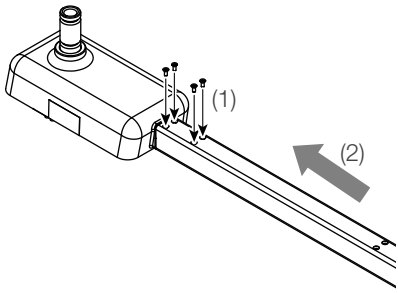

6. Insert the swing arm into the power supply box and fix it with four countersunk screws (M4 x 10, plated).

7. Reattach the cover of the power supply box in the reverse order of Step 1.

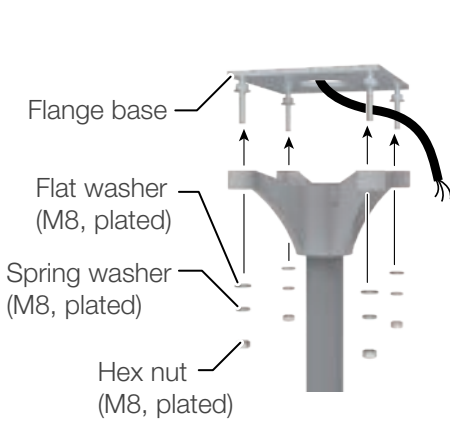

(4) Attach the light assembly to the flange base

1. Adjust the level of the ceiling flange with the ceiling pole set so that the ceiling pole is vertical, and fix the ceiling flange with the nuts and washers shown in the figure.

Pass through the power supply cable between the flange base and the ceiling flange.

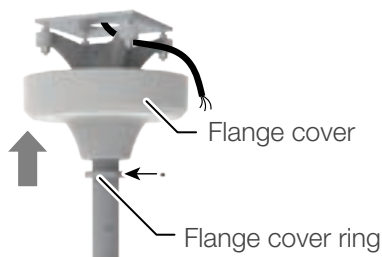

2. Slide the flange cover and flange cover ring (flat side up) over the ceiling pole and temporary fix them about half way up the pole.

Use only one hex socket set screw (M6 x 8, plated) (With red mec thread lock) as you will be moving the on final installation.

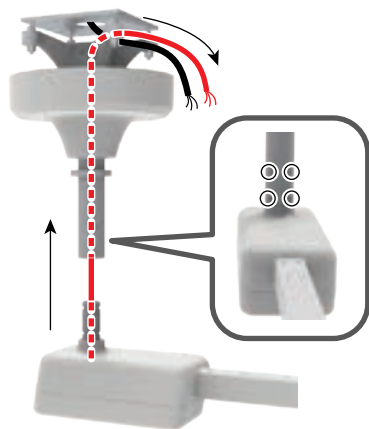

3. Pass the lead cable from the main unit through the ceiling pole, and pull it out from the position shown in the figure.

4. Attaching the main unit to the ceiling pole

Fix the main unit to the ceiling pole with hex socket set screws M5 x 10 plated (4 pcs.) attached.

Rotation angle of arm is 315°.

When fixing the arm to the ceiling pole, make sure that the range of motion of this arm covers the desired treatment position. (Be careful not to fall it off.)

3 Installation

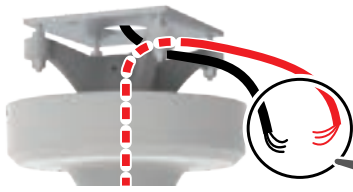

5. Connect the power supply cable in step 1 and the lead cable in step 3 with the one-touch connector. Return any excess wirings to the ceiling.

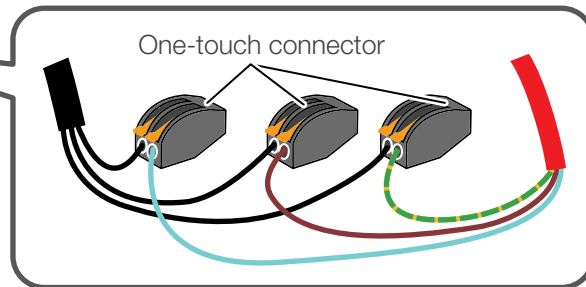

6. Reposition the flange cover and secure it with the flange cover ring. Secure three hex socket set screws (M6 x 8, plated) (With red mec thread lock).

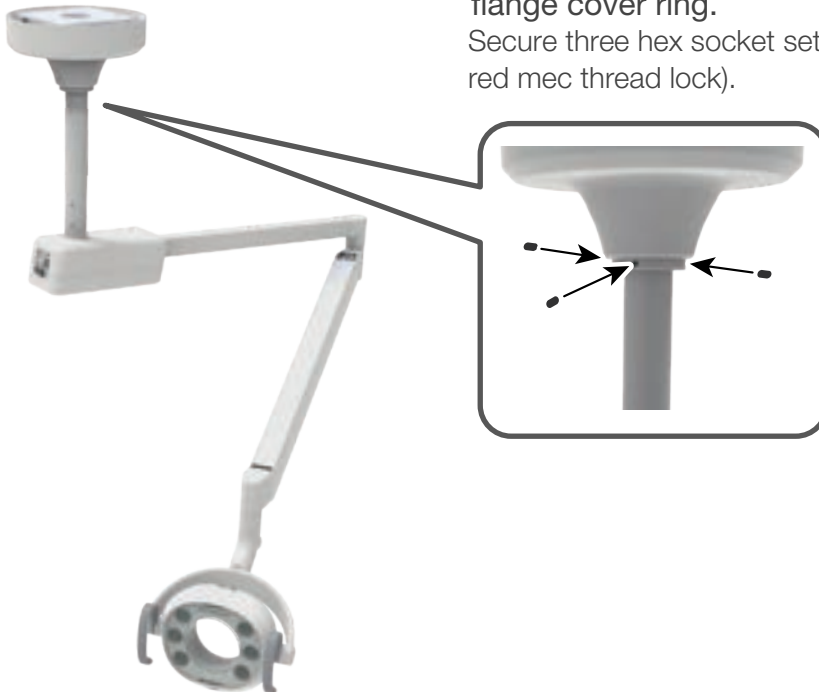

3-2-3 AL-D105G

Necessary tools

Phillips screwdriver No. 1, 2

Hex key wrench; width across flats: 2 mm / 2.5mm / 4mm)

Hammer, Socket wrench (13mm, 17mm)

Precaution for Installation

For safety in operation as well stability of the light source, the importance of proper ceiling structure can not be overemphasized. The ceiling structure capable of supporting 200lb (90kg) dead weight is requires.

(1) About construction of the ceiling

(A) In conventional ceilings with joists perpendicular to the center line of the light

Attach the pallet by at least six coach bolts (M8 x 75, plated). Suitable holes are provided in pallet for most installations, utilizing 16"(406 mm) or 24"(610 mm) center to ceiling joists. For other spacings or locations, additional holes can be cut in pallet.

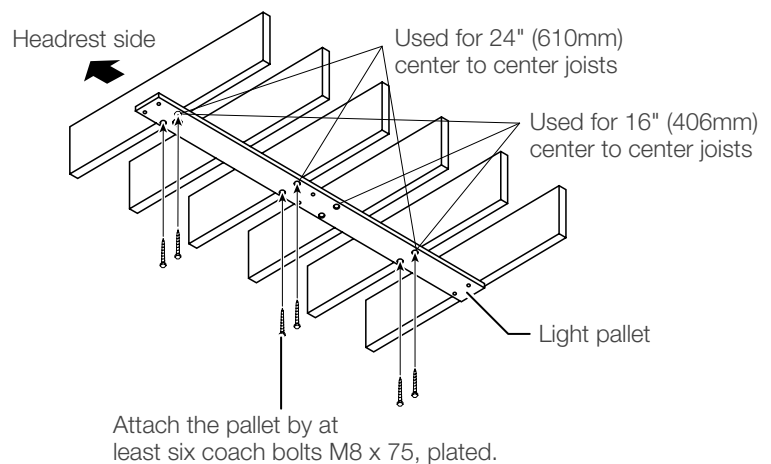

Locate transformer end of track at headrest end of chair. -
Not legrest.

(B) In conventional ceilings with joists parallel to the center line of the light

Attach the cross blocks in 3 places, and attach the pallet by at least six coach bolts (M8 x 75, plated).

Suitable holes are provided in pallet for most installations, utilizing 16" (406 mm) or 24" (610 mm) center to ceiling joists. For other spacings or locations, additional holes can be cut in pallet.

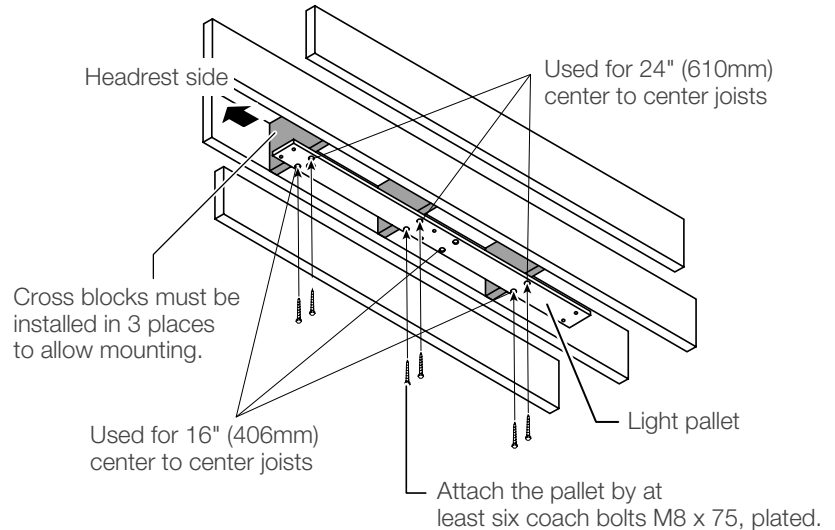

Locate transformer end of track at headrest end of chair. -
Not legrest.

(C) In suspended ceilings

For suspended ceilings, appropriate rigid structure must be attached to the ceiling framework to provide 200lb (90kg) dead weight capacity.

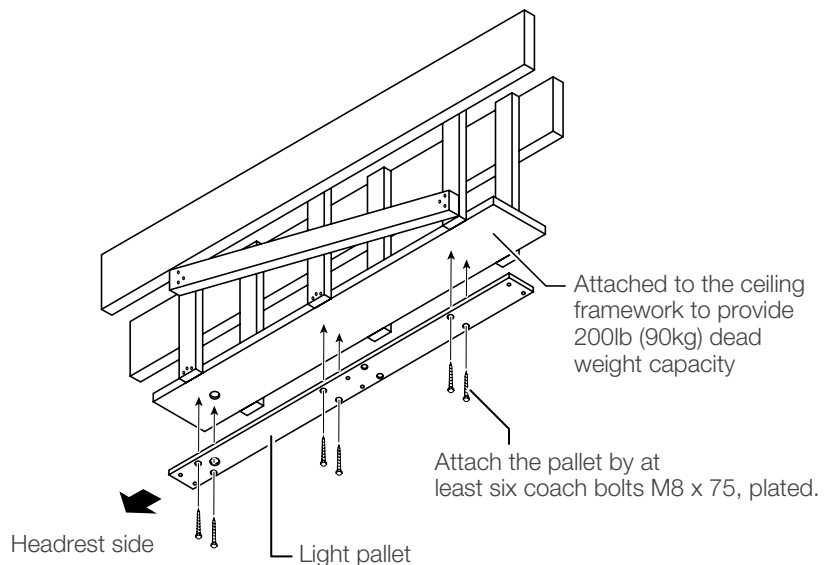

3 Installation

(2) Electrical preparation

Refer to below figure for the location of electrical feed opening in pallet, provide 3 wire, circuit (fuse or breaker) through flexible conduit with enough slack to protrude at least 2" (50mm) below the pallet when installed.

A readily accessible shut-off switch for this circuit is recommended. Use wiring suitable for 194°F (90°C) service.

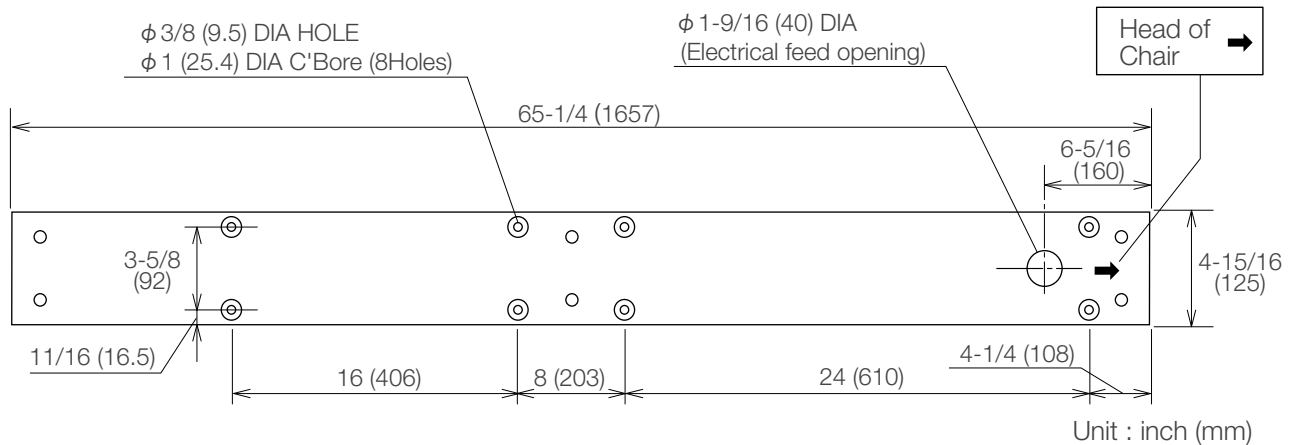

(3) Attach the track

1. Lead out the power supply cable from the ceiling where the track light is mounted.
2. Run the power supply cable from the ceiling through the pallet and mount the pallet.
3. Run the power supply cable from the ceiling through the electric feed opening of the track, and fix the opposite side of the electric feed opening on the truck to the pallet with two hex bolts (M8×25, plated) and two flat washers (M8 plated).

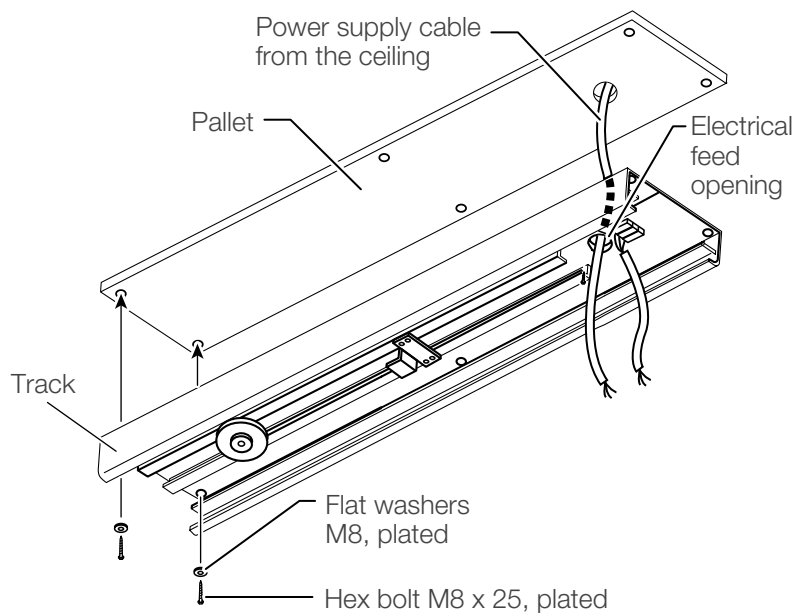

3 Installation

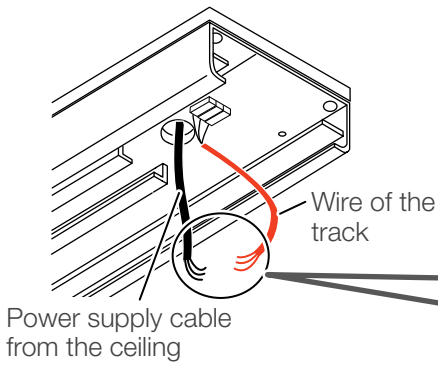

4. Connect the power supply cable from the ceiling and the cable of the track with the one-touch connector. Return any excess wirings to the ceiling.

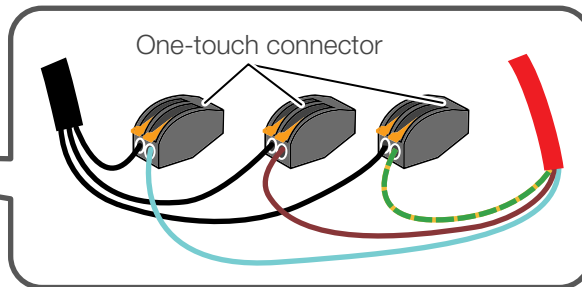

5. Attach the track to the pallet.

Fix the track with four hex bolts (M8 x 25, plated) and four flat washers (M8, plated).

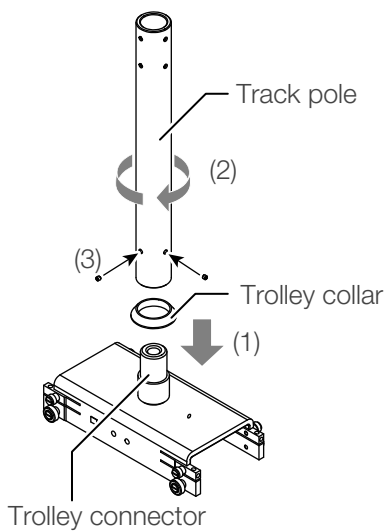
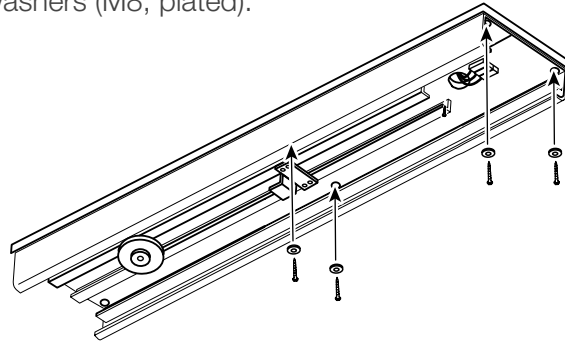

- (4) Attach Light assembly to trolley

1. Attach track pole to trolley.

Place the trolley collar over the trolley connector, screw the track pole onto the trolley connector, then fix the pole with two hex socket set screws (M5x6, plated). (Use the hex socket set screws attached to the mounting part.)

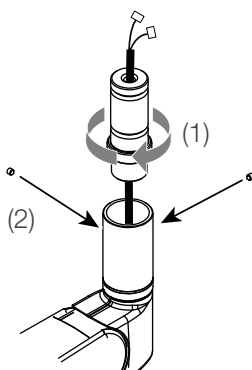

2. Attach the pole joint to the light.

Screw the pole joint into the end of the balance arm of the light, and fix the pole joint with two hex socket set screws (M5x6, plated). (Use the hex socket set screws attached to the mounting part.)

3 Installation

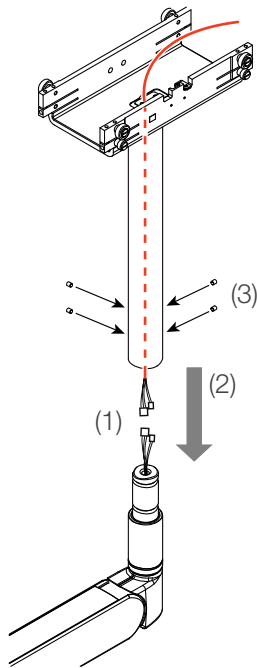

3. Attach track pole to light assembly.

- (1) Lead the electric cable coming from the track body through the track pole, then connect it with the connector coming from the light assembly.
- (2) Place the track pole over the pole joint.
- (3) Fix them with four hex socket set screws (M5×8, plated). (Use the hex socket set screws attached to the mounting part.) (These screws also limit the swing range of balance arm.)

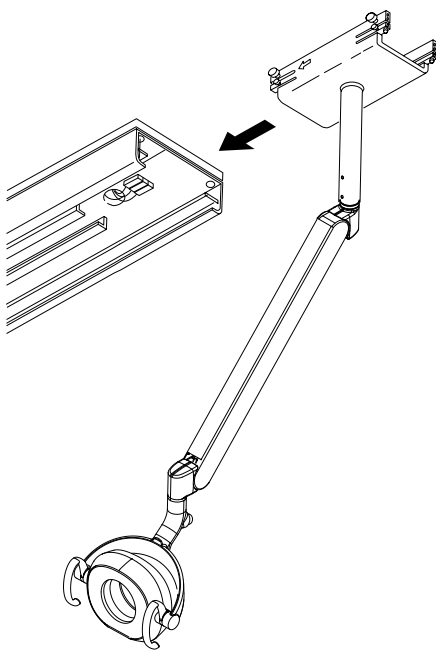

(5) Attach light assembly to the track

1. Slide the trolley onto the track (end near electrical opening) with the arrow on the trolley oriented toward the pulley on the track.
2. Carefully guide the cable from the trolley, around the spring-loaded pulley and back toward the end of track.
3. Clamp the cable to the track.
4. Install rubber bumpers (4 pieces) at the end of the track in the holes provided. Fix the rubber bumpers with bind screws M4 x 10 (4 pieces)

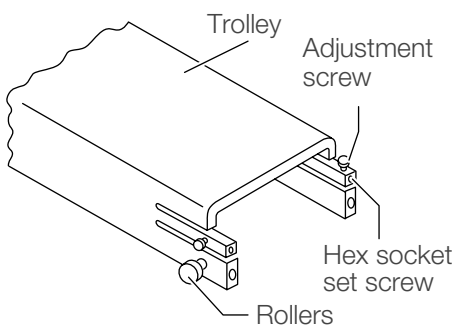
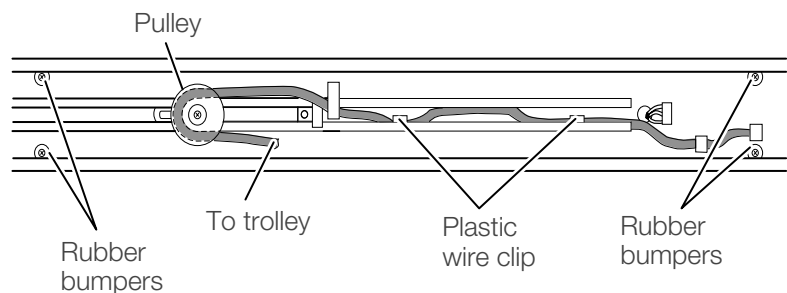

5. Check operation of the trolley.

It is factory adjusted to provide smooth effortless travel, without play, however rollers can be readjusted if necessary. Loosen the hex socket set screw and adjust the socket cap screw to vary roller clearance.

3 Installation

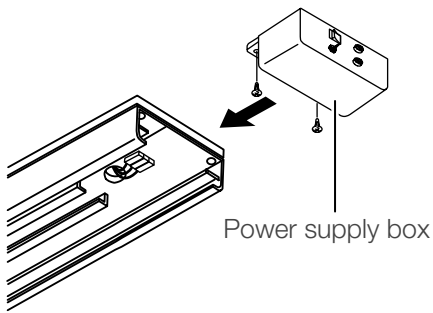

6. Attach the power supply box.

Fix the power supply box with pan head screws (4P, M4 x 15, plated).

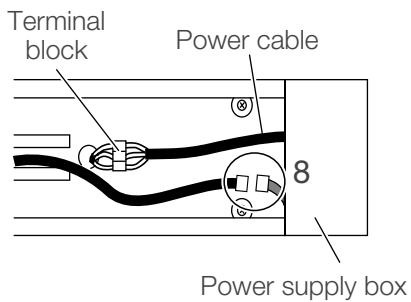

7. Connect the power cable from the power supply box to the terminal block.

Retain the cables under the plastic clip.

8. Connect the connector of the power supply box and the connector of the track.

9. Carefully slide bottom cover onto the track from free end.

Be sure to engage lip onto Z bracket.

10. Attach the end-cap with the pan head screws M4 x 15, plated (2 pieces).

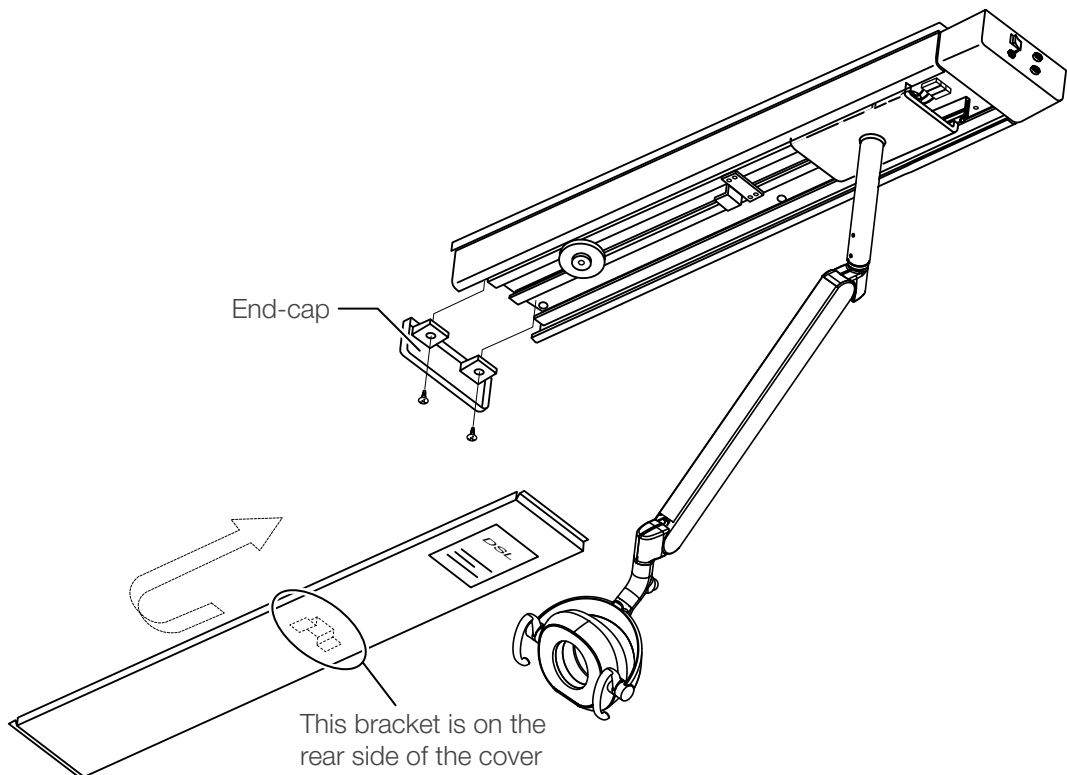

11. Slide the trolley back and forth, checking for binding or rubbing.

3-2-4 AL-D106G-QU

When mounting to Quolis 5000 unit

Necessary tools

Phillips screwdriver No. 1,2,3

Hex key wrench; width across flats: 2 mm,3 mm,4 mm

Long nose pliers

(1) Attach the dental light

Also refer to dental unit installation instructions for installation of the dental light.

1. Remove the two button screws (M6 x 8, White) from the balance arm joint.
2. Pass the lead cable through the light pole.
The light pole is packed with the dental unit section.
3. Insert the balance arm joint into the light pole and fix it with two button screws (M6 x 8, White) .

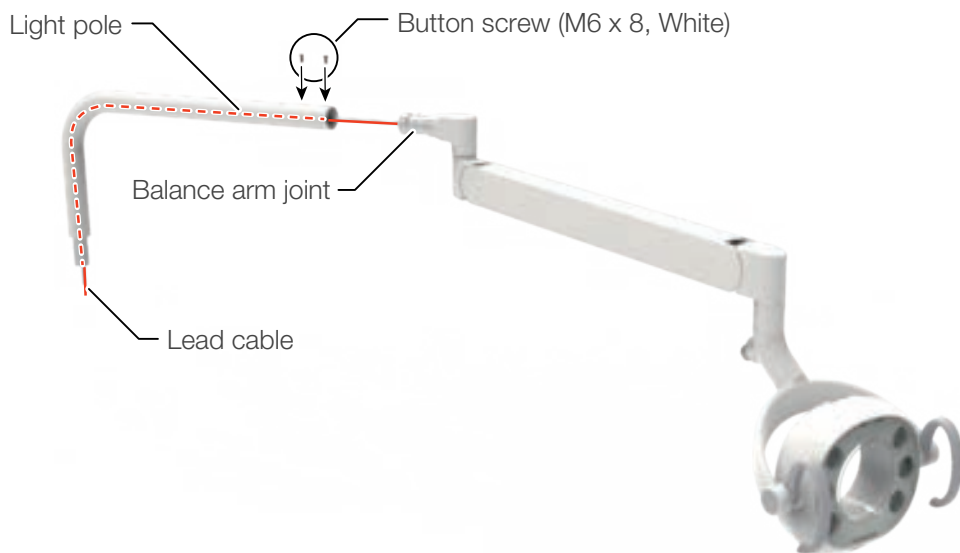

4. Feed the light cable through the swing arm and pull the end of the light cable from the lower end of the swing arm.
5. Mount the light pole onto swing arm.

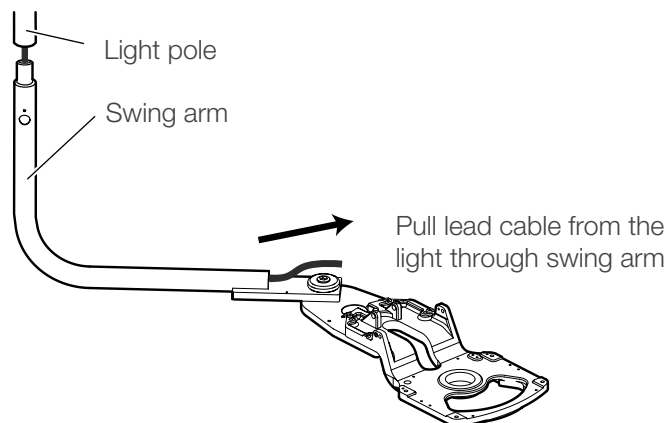

3 Installation

(2) Attach the switch box

1. Attach the switch box onto the swing arm with two screws (M4 x 8).

Fix the Green/Yellow line from power supply box wire harness together with same screw as shown in figure.

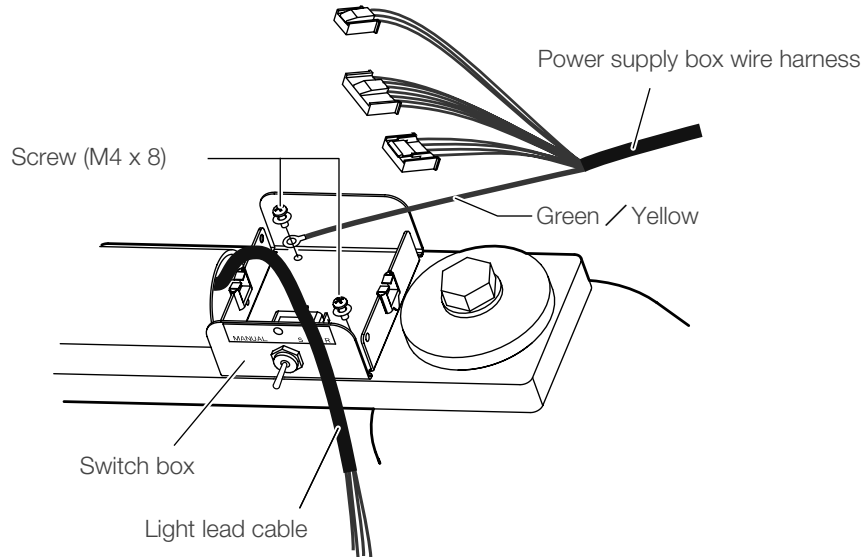

2. As illustrated below, place the wire harness inside the guide.

The part with the cable tie should be inside the box.

Lead all the wires underneath the switch, and connect the connectors (3 pins) from the power supply box wire harness and the mode selection switch.

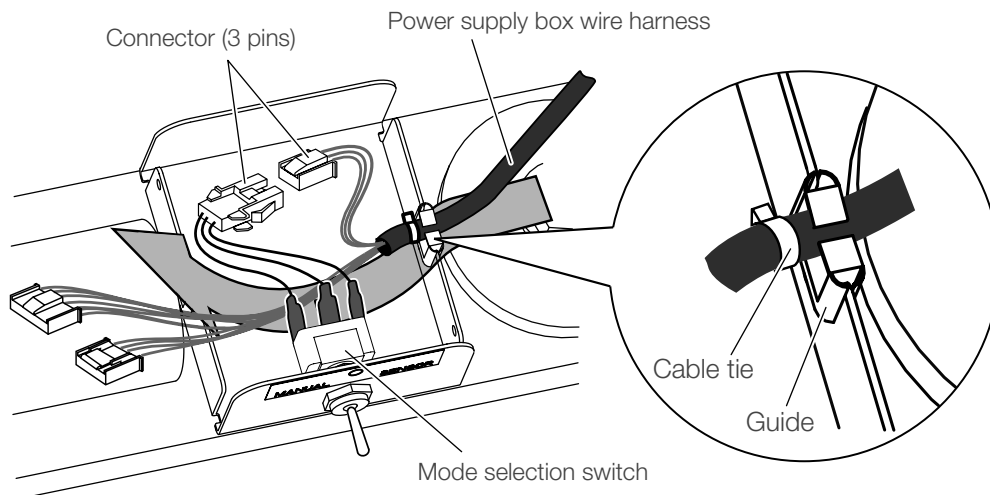

3 Installation

3. As illustrated below, place the light lead cable inside the cable guide.

The part with the cable tie should be inside the box.
Make sure that the light lead cable should be above that from the power supply box.
Connect the connectors (4 pins and 5 pins) of the wire harnesses.

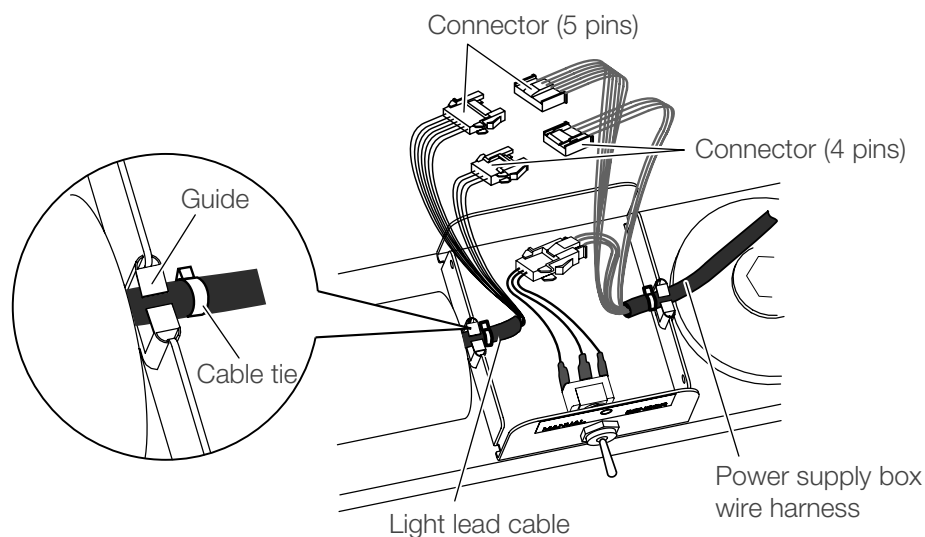

4. Put all the wires inside the switch box.
Place the switch box cover on the switch box and fix it with two screws (M4 x 6).

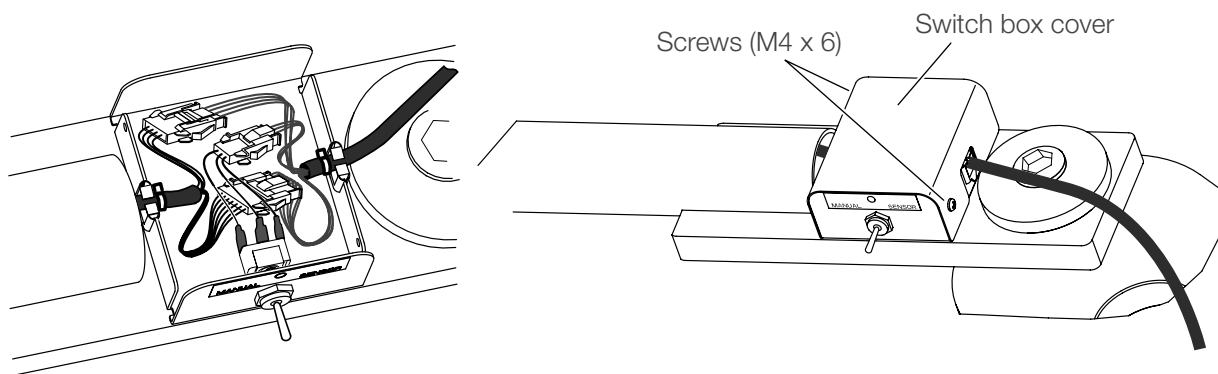

3 Installation

(3) Wiring between switch box and power supply box assembly

1. Insert the wire harness down through the hole of the swing arm bracket.

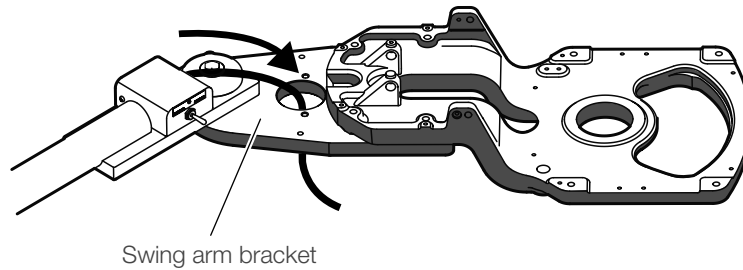

2. Feed the wire harness through the flange parts as described below.

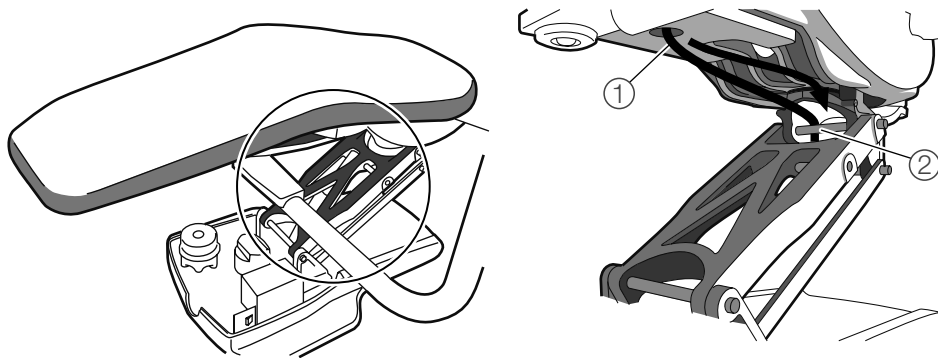

3. (1) Attach the power supply box by the motor pump of the chair with two screws (M5 x 12).
- (2) Fix the Green/Yellow line from power supply box wire harness to junction box with screw (M5 x 12).

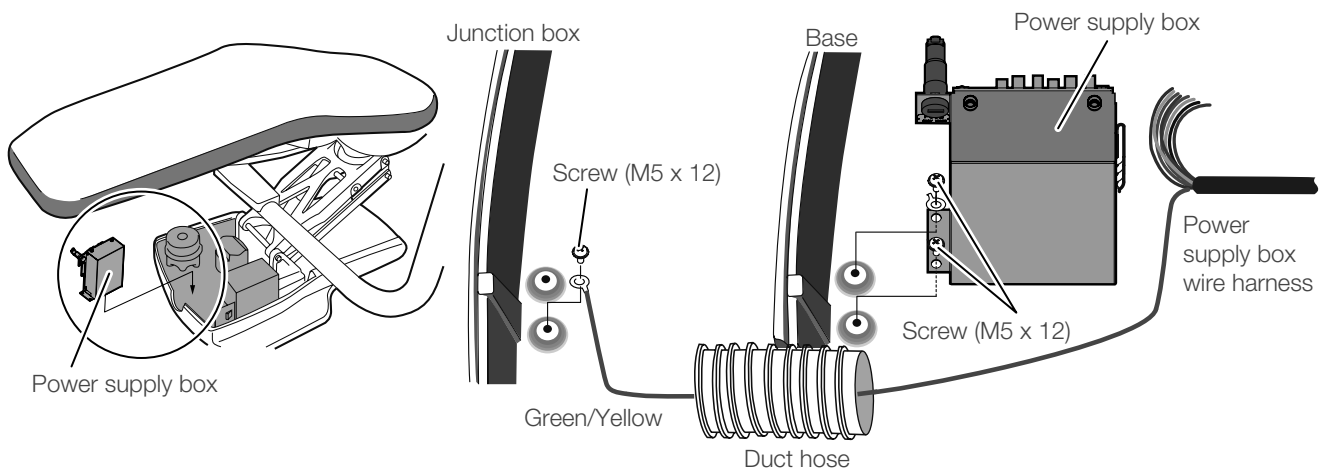

3 Installation

4. Attach the connectors onto the light control PCB of the power supply box.

A : Connect the connectors (3 pins, 3pins) from power supply box wire harness to light control PCB.

B : Connect the connector (4pins).

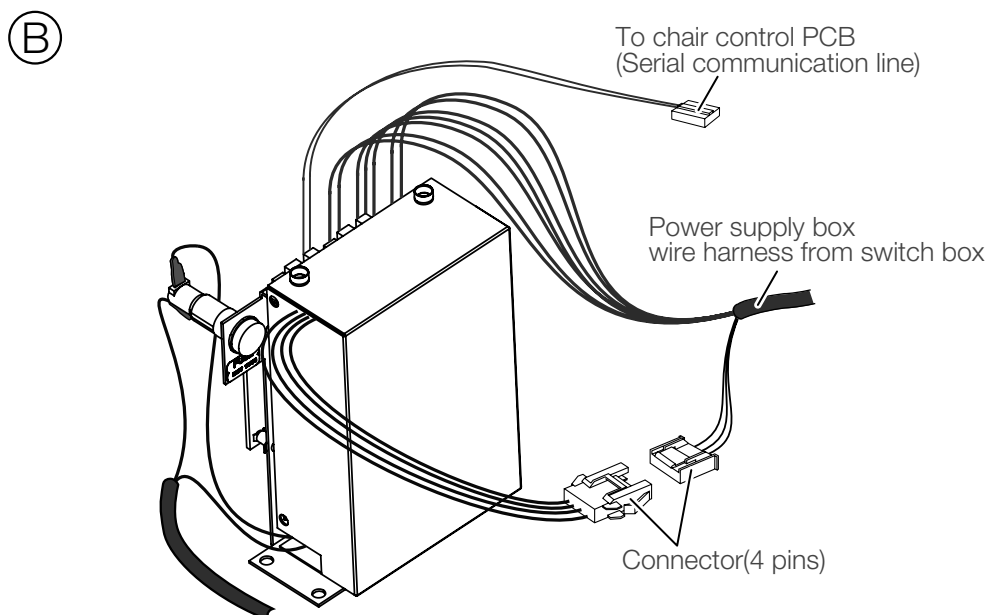
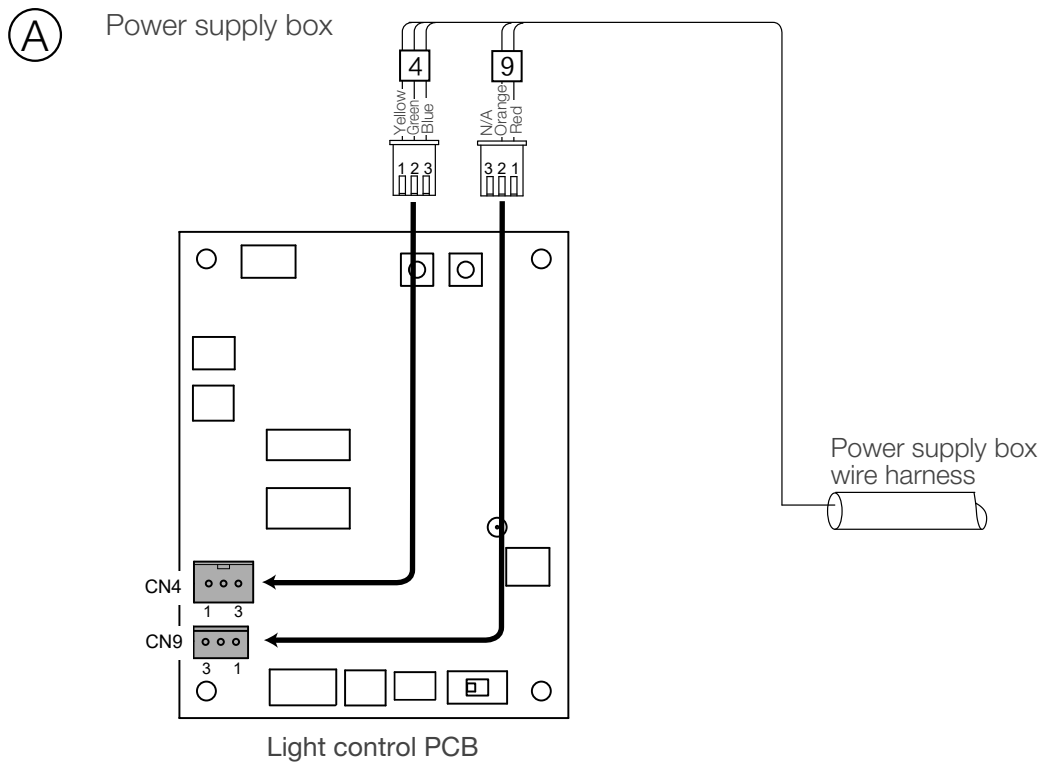

3 Installation

5. Connect the power supply wire from power supply box to the connector on the metallic box inside the junction box.

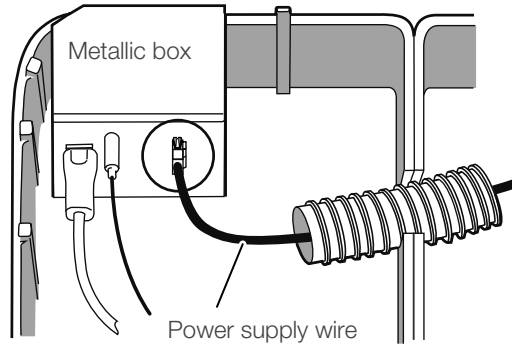

(4) Wiring between light control PCB and chair control PCB

1. Remove two screws for chair control pcb box.

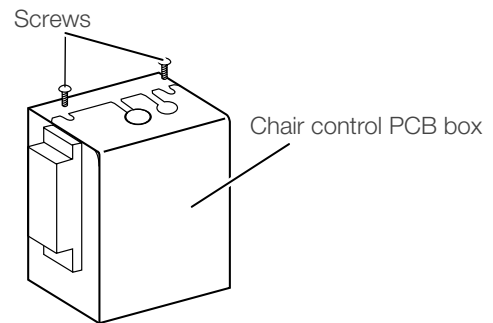
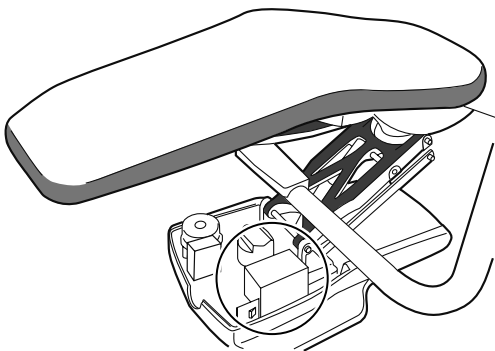

2. Open the lid to access to the chair control PCB.

Remove the connected wire harness for AL-820 from CN8. Replace with the wire harness for AL-D106G-QU that comes out from power supply box. Close the lid and fix with 2 screws.

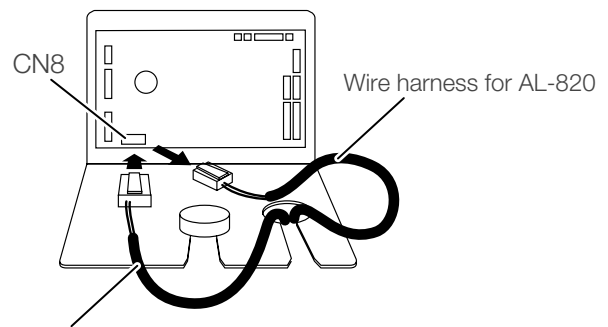
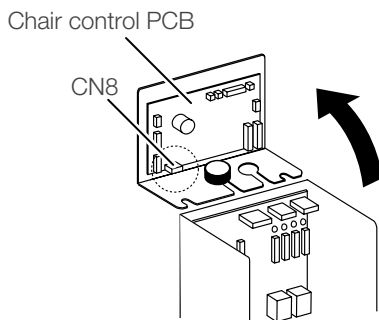

Wire harness for AL-D106G-QU from power supply box (Serial communication line)

3 Installation

(5) Setting the lower volume limit of the dental light intensity

1. Turn on the power of the unit.

2. Turn the light intensity control volume of the dental light counterclockwise to its lowest setting.

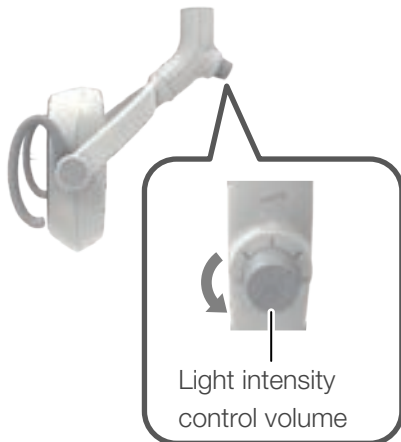

3. Push the switch (SW1, CHECK) on the light control PCB in the power supply box.

LED2 (Yellow) on the light control PCB blinks.

4. Push the switch (SW2, ON_OFF) on the light control PCB.

LED2 (Yellow) on the light control PCB turns off.

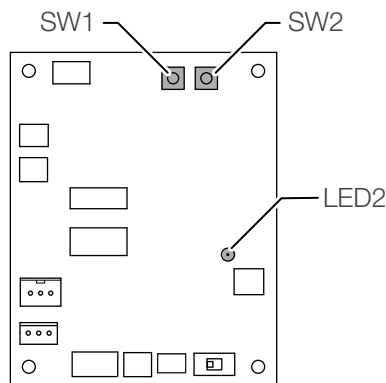

Light control PCB

3 Installation

When mounting to Quolis unit

Necessary tools

Phillips screwdriver No. 1,2

Hex key wrench; width across flats: 2mm, 2.5mm, 4mm,
6mm, 8mm, 10mm

Long nose pliers

(1) Attach the dental light

1. Attach the mounting bracket.

(Only specification without doctor unit.

For specifications with a doctor unit, go to Step 2.)

(1) Hook the countersunk screw on the mounting bracket to the chair.

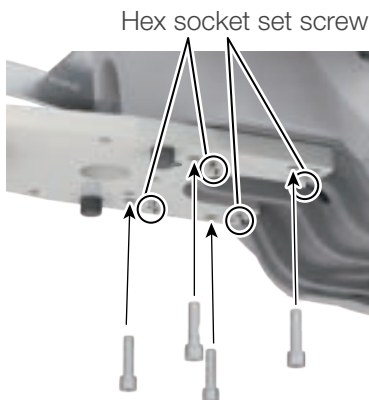
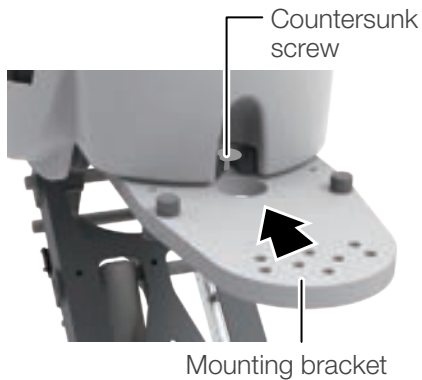

(2) Temporarily fasten the mounting bracket with cap bolts (4 pieces).

(3) Attach the hex socket set screws (4 pieces) and horizontally adjust the mounting bracket.

(4) Tighten the bolts in (2) and fix the mounting bracket.

2. Attach the light swing arm

(1) Attach the light swing arm to the mounting bracket as shown in the figure.

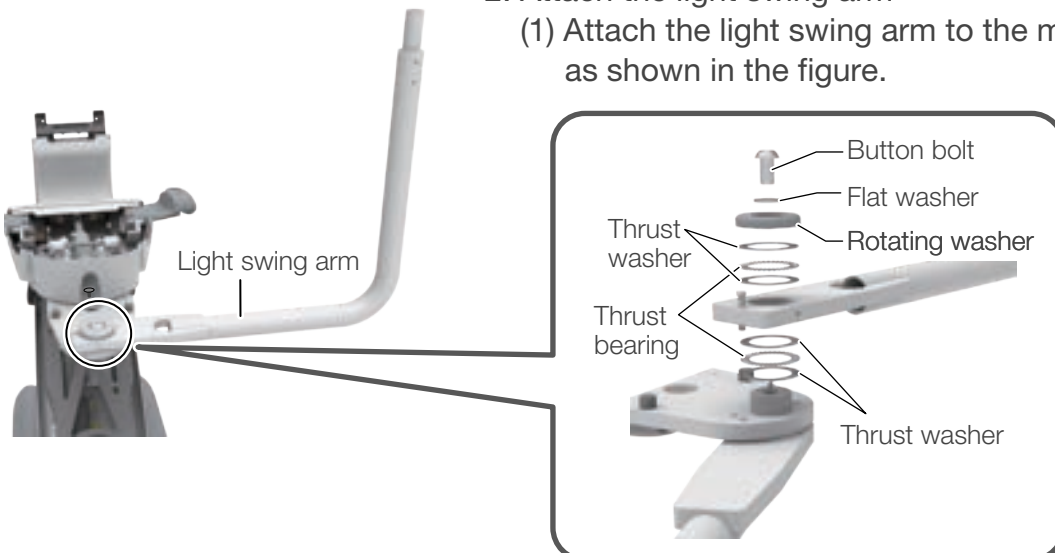

3 Installation

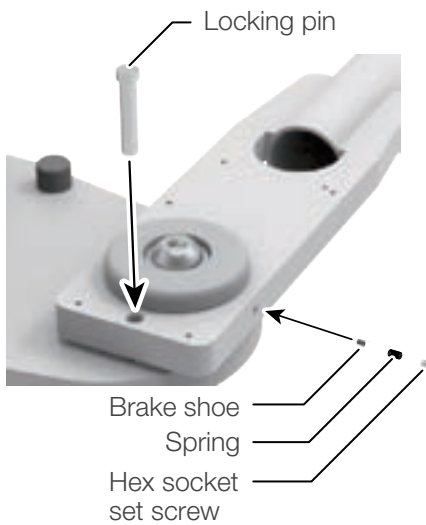

(2) Set the brake shoe, spring and hex socket set screw.

(3) Set the light swing arm to the desired angle and fix it with the locking pin.

3. Attach the dental light to the light pole.

(1) Remove the two button screws (M6 x 8, White) from the balance arm joint.

(2) Pass the lead cable through the light pole.
The light pole is packed with the dental unit section.

(3) Insert the balance arm joint into the light pole and fix it with two button screws (M6 x 8, White).

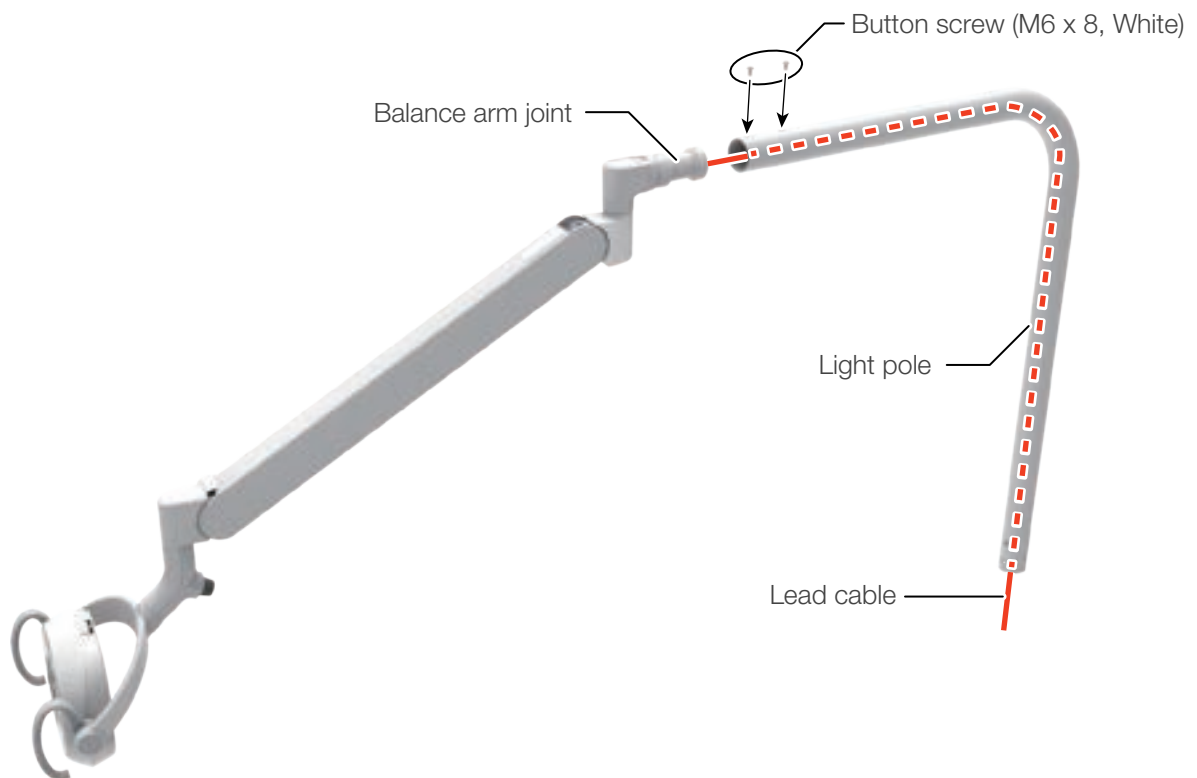

3 Installation

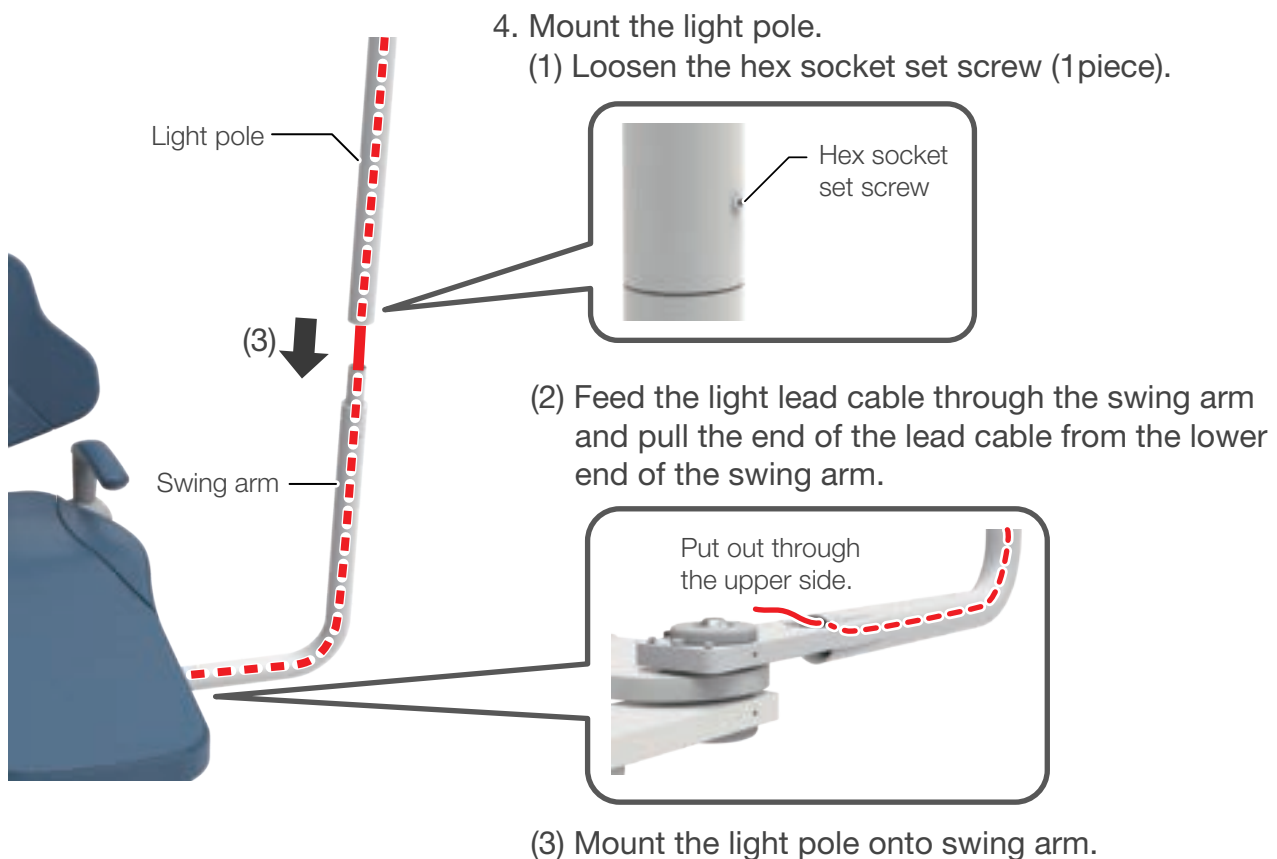

(4) Adjust the brake with the hex socket set screw loosened in the (1).

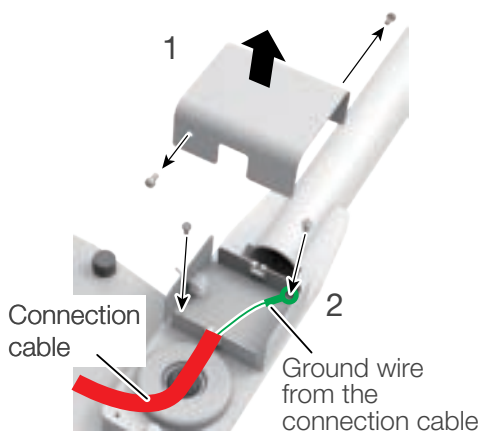

(2) Attach the switch box.
1. Remove the switch box cover. (2 pan head screws)
2. Attach the switch box onto the swing arm with two pen head screws M4 x 8.
Fix together the ground wire of the connection cable.

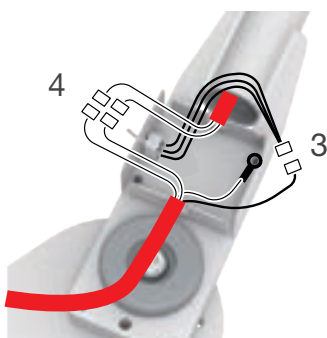

3. Connect the connector from the connection cable to the connector from the switch box (1pc.).
4. Connect the connectors from the connection cable and the connectors from the lead wire in the light (2 pcs.).
5. Place all cables in the switch box and attach the cover for switch box with reverse order of step 1.

3 Installation

(3) Attaching and wiring for P.C.Board unit

1. Attach the P.C.Board unit to the chair base.
(2 pan head screws M5).

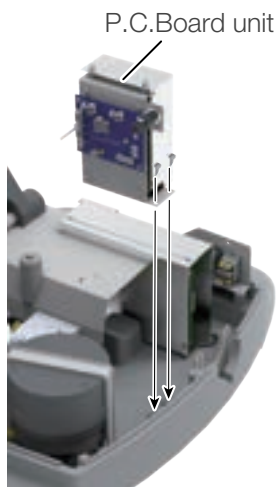

2. Pass the connection cable through the swing arm bracket hole and pass it through the lower part of the chair as shown in the figure.

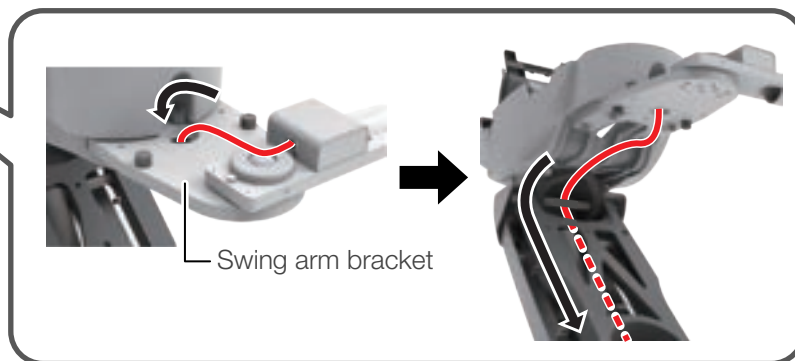
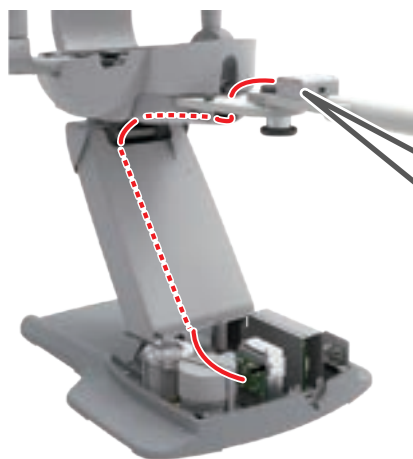

3. Attach the ground wire of the connection cable.

4. Connect the connectors from the connection cable to the light control PCB as shown in the figure.

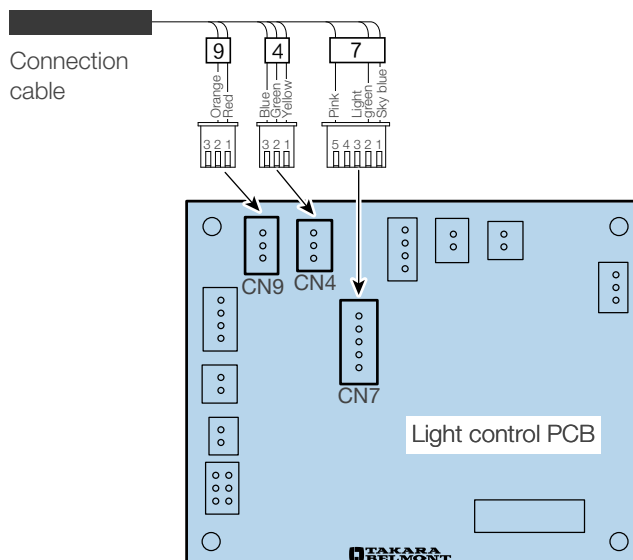
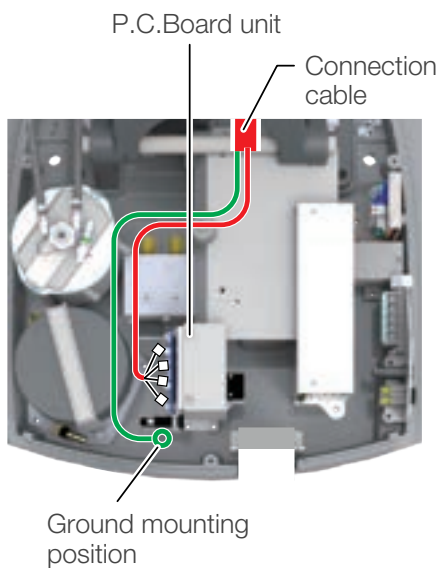

3 Installation

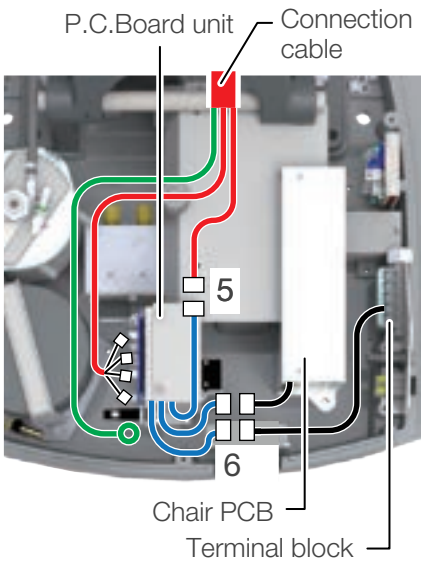

5. Connect the connectors from the connection cable to the connector from the P.C.Board unit.
6. Connect the connectors from the chair PCB and chair terminal block to the connector from the P.C.Board unit.

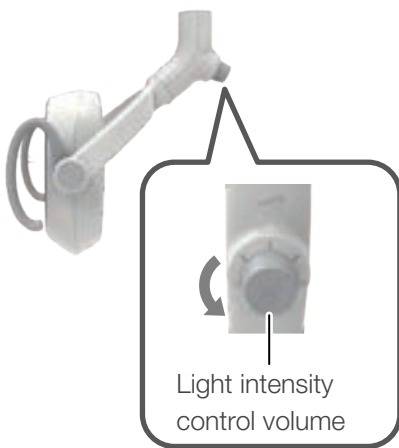

(4) Setting the lower volume limit of the dental light intensity

1. Turn on the power of the unit.
2. Turn the light intensity control volume of the dental light counterclockwise to its lowest setting.
3. Push the switch (SW1, CHECK) on the light control PCB in the power supply box.
LED2 (Yellow) on the light control PCB brinks.
4. Push the switch (SW2, ON_OFF) on the light control PCB.
LED2 (Yellow) on the light control PCB turns off.

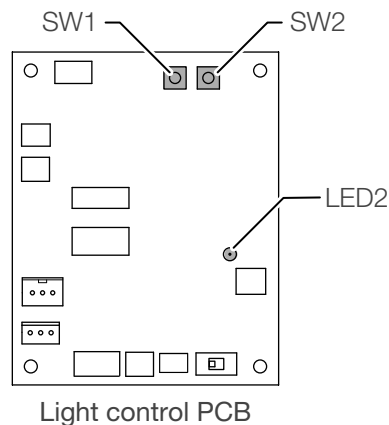

3-2-5 AL-D106G-EV / AL-D109W-X / AL-D109W-XN

Necessary tools

Phillips screwdriver No. 1,2,3

Hex key wrench; width across flats: 2 mm, 3 mm, 4 mm

Long nose pliers

(1) Attach the light to the light pole

Also refer to dental unit installation instructions for installation of the dental light.

1. Remove the two button screws (M6 x 8, White) from the balance arm joint.
2. Pass the lead cable through the light pole.
The light pole is packed with the dental unit section.
3. Insert the balance arm joint into the light pole and fix it with two button screws (M6 x 8, White) .

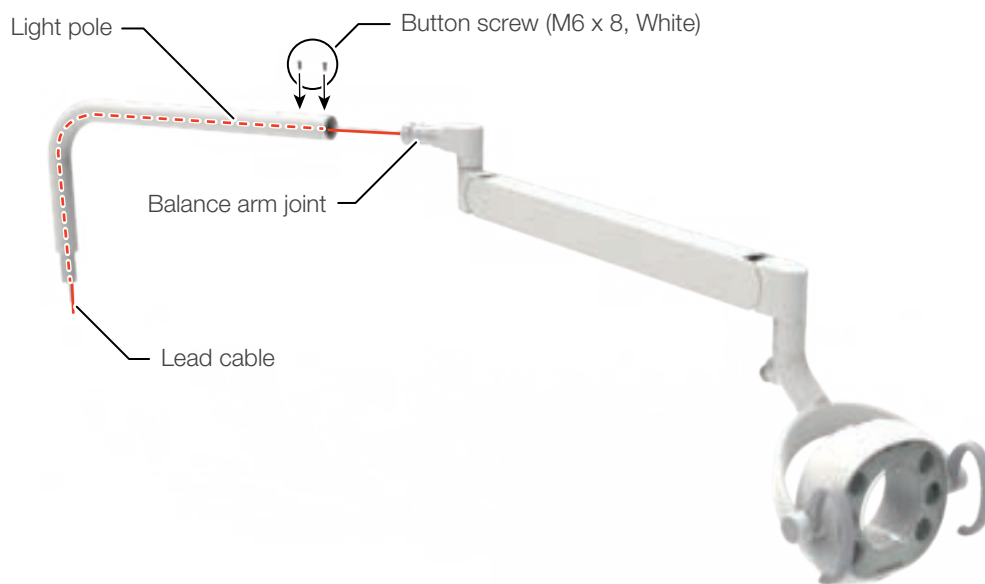

3 Installation

(2) Attach the light to the dental unit

Attach the light to the X-Calibur Unit

(For Swing Arm Mount : AL-D109W-X)

1. Feed the light lead cable through the swing arm and pull the end of the lead cable from the lower end of the swing arm.
2. Mount the light pole onto swing arm.
3. Insert the brake disks, hex socket set screws (M6 x 5, SUS) in to the light pole and adjust the brake with hex socket set screws.

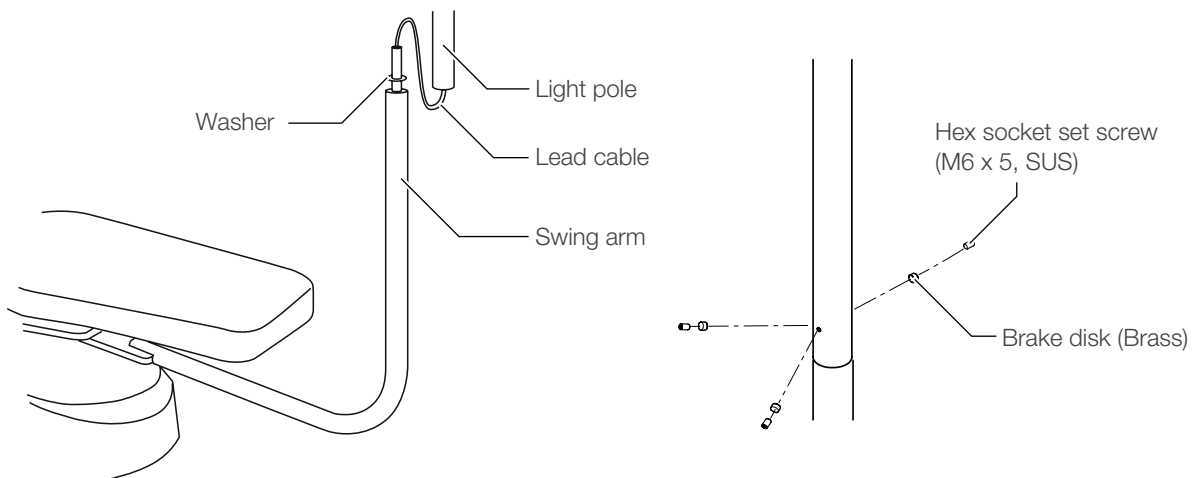

Attach the light to the X-Calibur Unit

(For Cuspidor Mount : AL-D109W-XN)

1. Feed the light lead cable through the light support rod and pull the end of the lead cable from side of the cuspidor post .
2. Mount the light pole onto light support rod.
3. Insert the brake disks, hex socket set screws (M6 x 5, SUS) in to the light pole and adjust the brake with hex socket set screw. (See above figure)

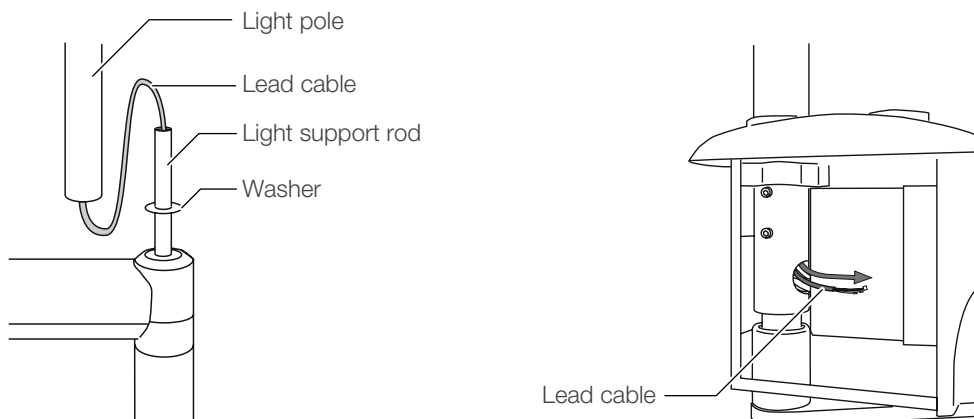

3 Installation

Attach the light to the Evogue Unit (For Swing Arm Mount : AL-D106G-EV)

1. Feed the light lead cable through the swing arm and pull the end of the lead cable from the lower end of the swing arm.
2. Mount the light pole onto swing arm.
3. Hex socket set screws (M6 x 5, SUS) in to the light pole and adjust the brake with hex socket set screws.

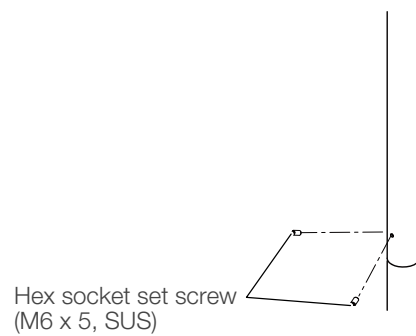
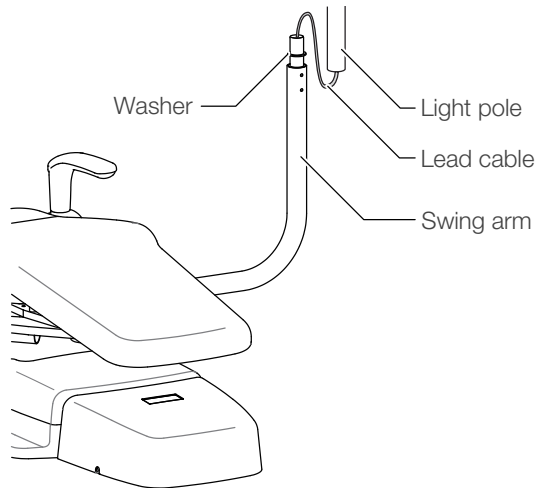

Attach the light to the Evogue Unit (For Cuspidor Mount : AL-D106G-EV)

1. Feed the light lead cable through the light post and pull the end of the lead cable from side of the cuspidor post .
2. Mount the light pole onto light post.
3. Hex socket set screw (M6 x 5, SUS) in to the light pole and adjust the brake with hex socket set screw.

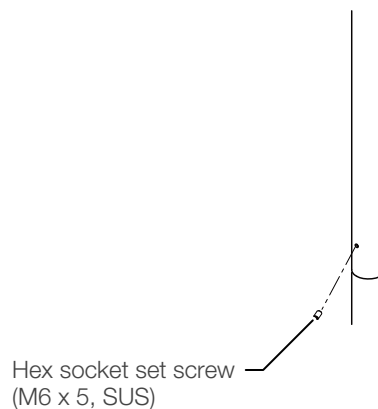
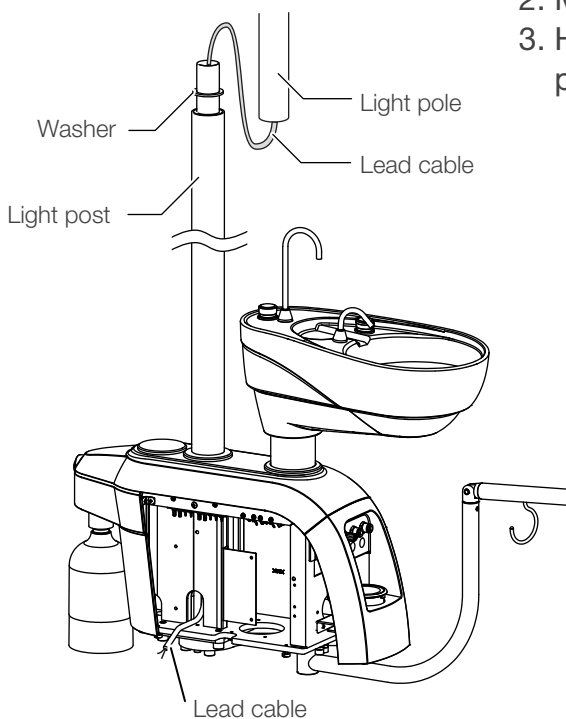

3 Installation

(3) Install the switch box

1. Open the switch box and connect connection cable and lead cable from light head as shown in the figure below.

X-Calibur Swing Arm Mount & Cuspidor Mount (BEL-50/Q3300/Q5500)
 Evogue Swing Arm Mount & Cuspidor Mount (Q3300/Q5500)
 Evogue Swing Arm Mount (BEL-50)

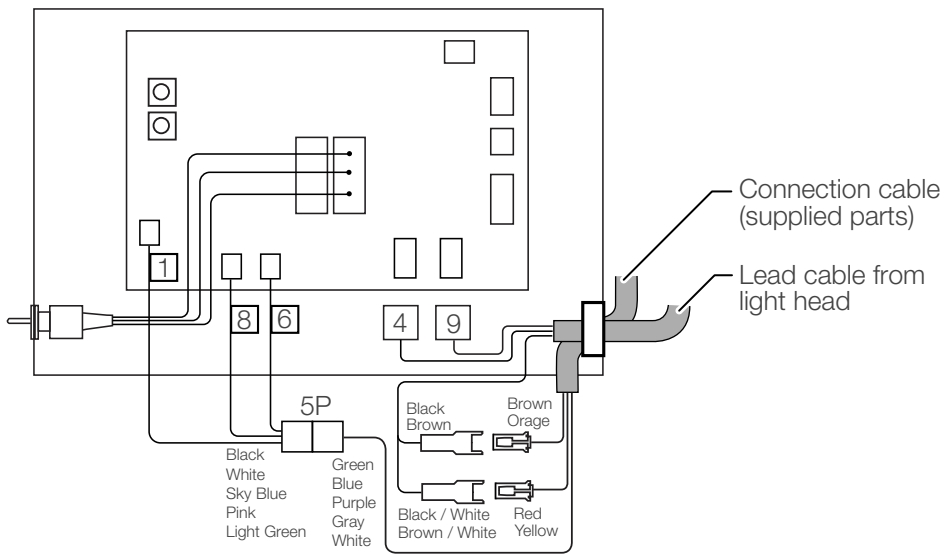

Evogue Cuspidor Mount (BEL-50)

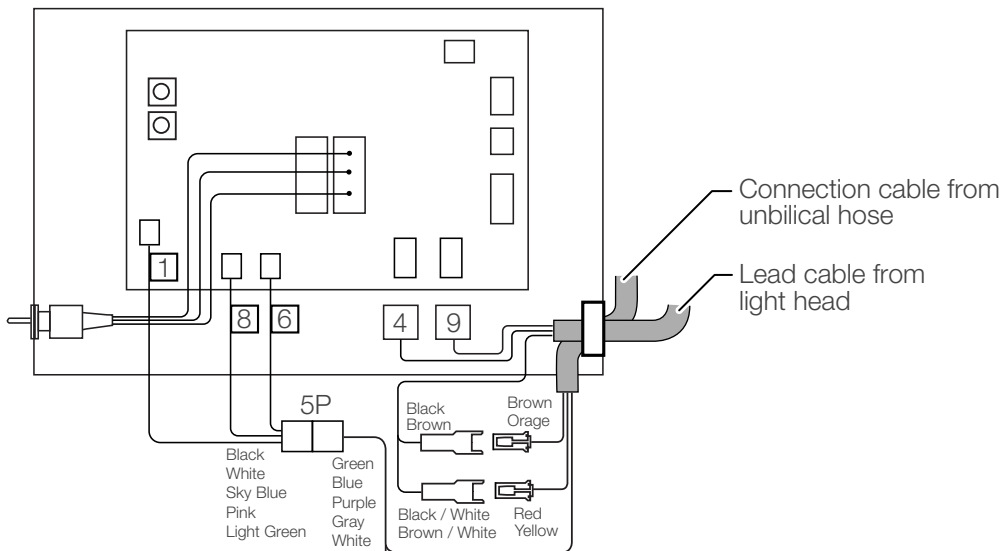

*This 4P connector's connection is not necessary.

3 Installation

2. Attach the switch box and pass the connection cable through to the junction unit as shown in the figure below.

X-Calibur Swing Arm Mount (AL-D109W-X)

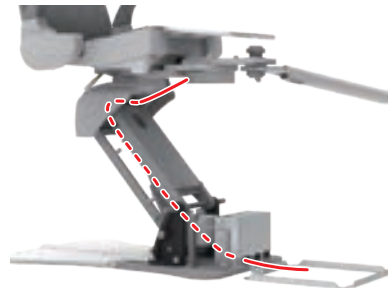
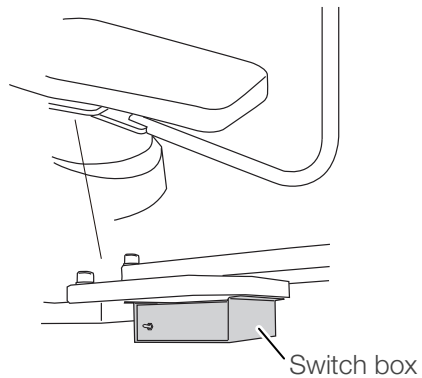

Pass the connection cable through the chair and to the junction unit.

X-Calibur Cuspidor Mount (AL-D109W-XN)

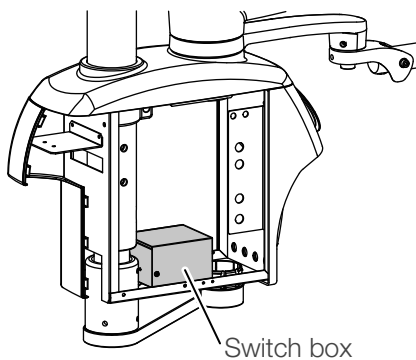

Pass the connection cable through the umbilical hose and to the junction unit.

Evogue Swing Arm Mount (AL-D106G-EV)

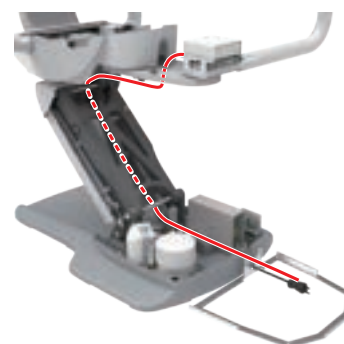
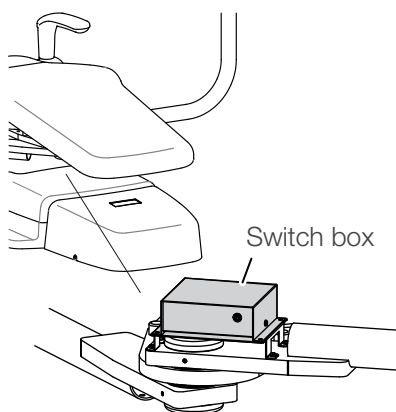

Pass the connection cable through the chair and to the junction unit.

3 Installation

Evogue Cuspidor Mount(AL-D106G-EV)

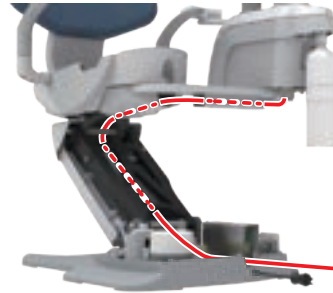
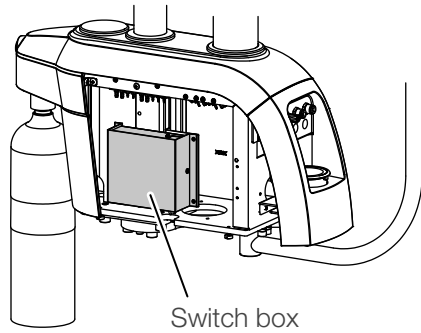

Pass the connection cable through the hole for the swing arm bracket and pass it to chair lower front.

(5) Install the power supply box

1. Attach the power supply box to the junction unit.
2. Connect the connector from the power supply box to connection cable.
3. Pipe the air and water supply in the junction unit.
4. After all connections are completed, connect the power cord.

X-Calibur Swing Arm Mount (AL-D109W-X)

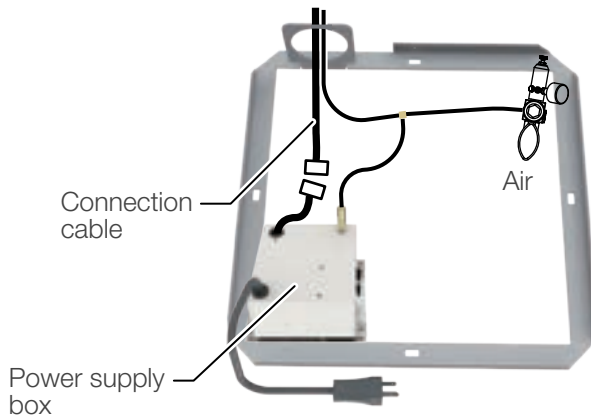

X-Calibur Cuspidor Mount (AL-D109W-XN)

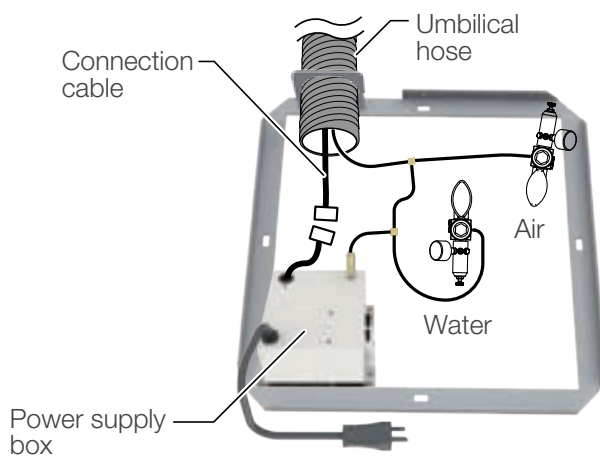

3 Installation

Evogue Swing Arm Mount (AL-D106G-EV)

Combine with BEL-50 Chair

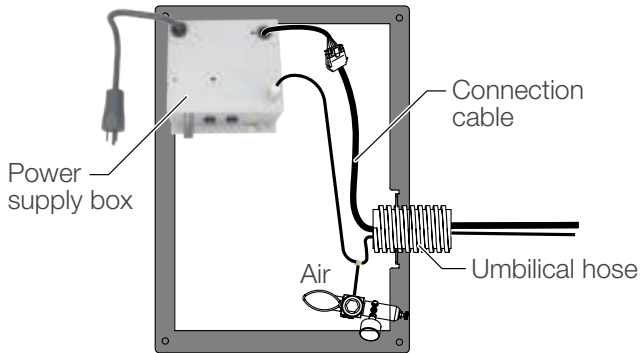

Combine with Q3300 Chair

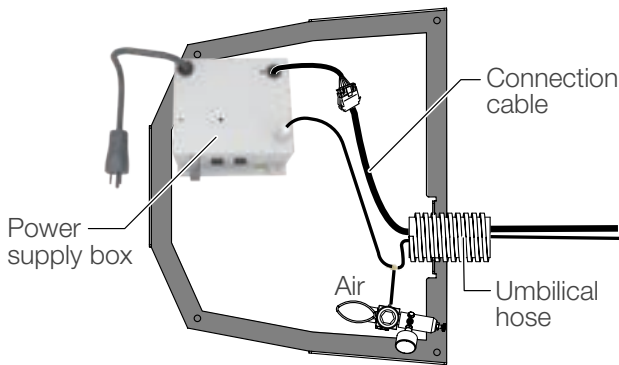

Combine with Q5500 Chair

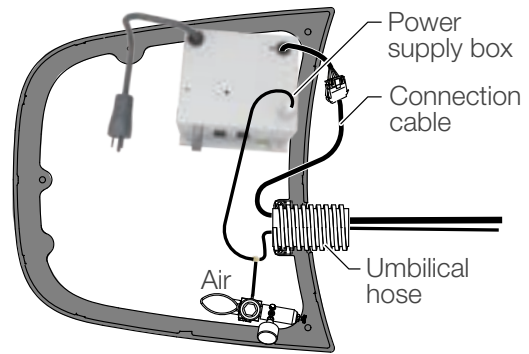

Evogue Cuspidor Mount(AL-D106G-EV)

Combine with BEL-50 Chair

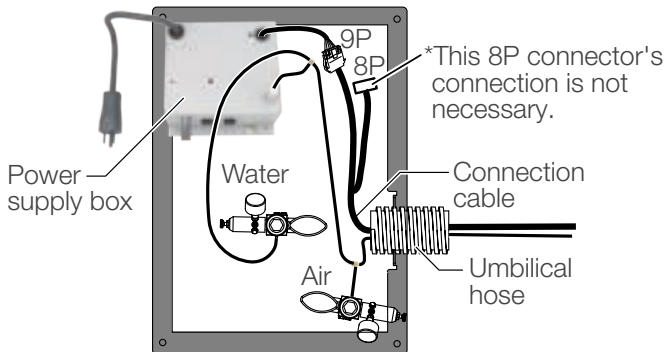

Combine with Q3300 Chair

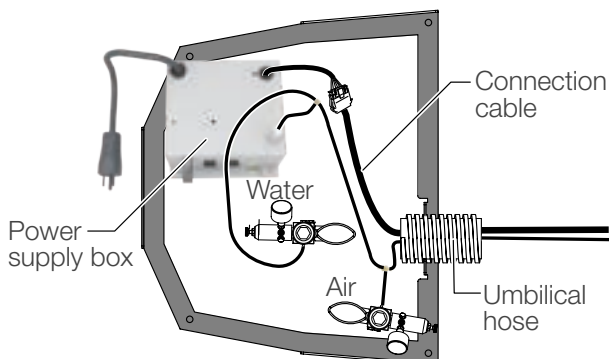

Combine with Q5500 Chair

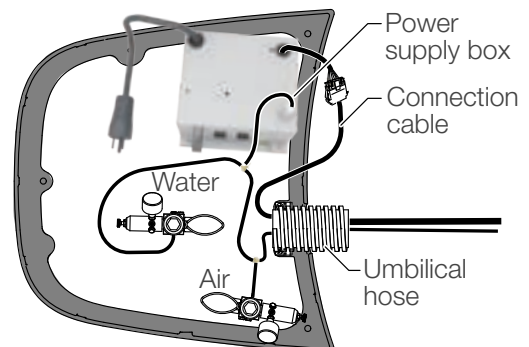

3 Installation

(6) Setting the lower volume limit of the dental light intensity

1. Turn on the power of the unit.

2. Turn the light intensity control volume of the dental light counterclockwise to its lowest setting.

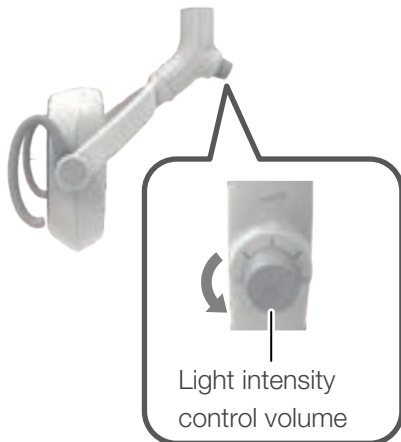

3. Push the switch (SW1, CHECK) on the light control PCB in the power supply box.

LED2 (Yellow) on the light control PCB blinks.

4. Push the switch (SW2, ON_OFF) on the light control PCB.

LED2 (Yellow) on the light control PCB turns off.

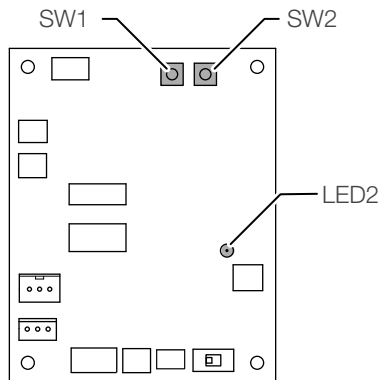

Light control PCB

3-2-6 AL-D107G

Necessary tools

Phillips screwdriver No. 1,2

Hex key wrench; width across flats: 2 mm, 2.5 mm, 4 mm

(1) Attach the light pole to the cabinet

1. Pass the connection cable through light pole.

2. Pass the connection cable in step 1 through the pole receptacle and attach the light pole to the pole receptacle.

To make this job easier, hold the light pole horizontally, and swing it right and left while inserting into pole receptacle.

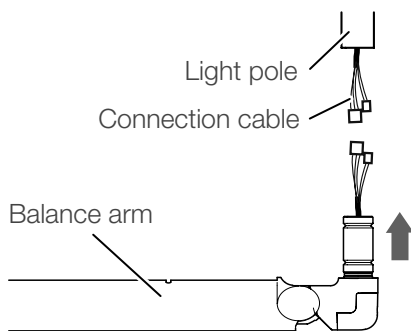
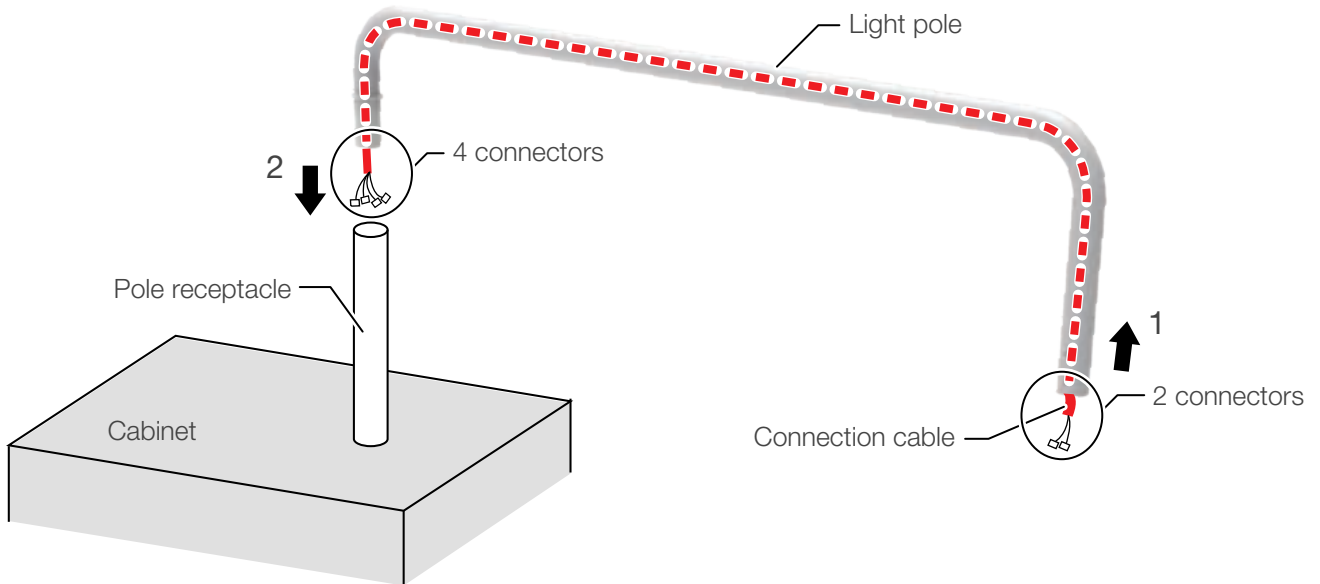

(2) Attach the balance arm to the light pole.

1. Connect the balance arm connector and the connection cable connector.

2. Insert the balance arm to the light pole.

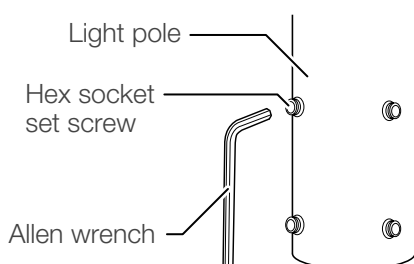

3. Determine the range of the balance arm and fix the hex socket set screws (4 pieces) fixed at the attaching point.

3 Installation

(3) Connect the wirings in the cabinet.

1. Attach the P.C.Board unit to the cabinet.

2. Connect the connectors of the connection cable as shown in the figure.

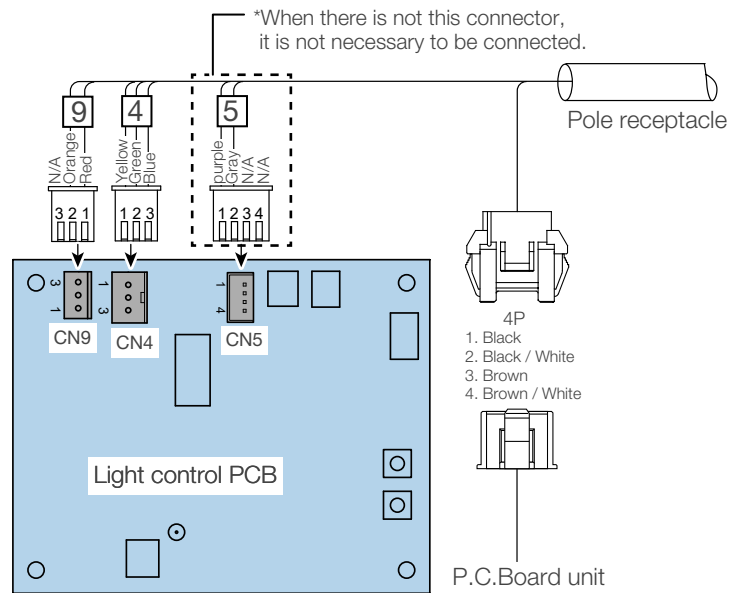

Refer to the cabinet installation manual to install the following accessories.

- Switch
- Fuse box
- Ground wire
- Noise filter
- Harness wire seals for cabinets

3 Installation

3-2-7 AL-D108G

Wall Plate pre-installation requirement

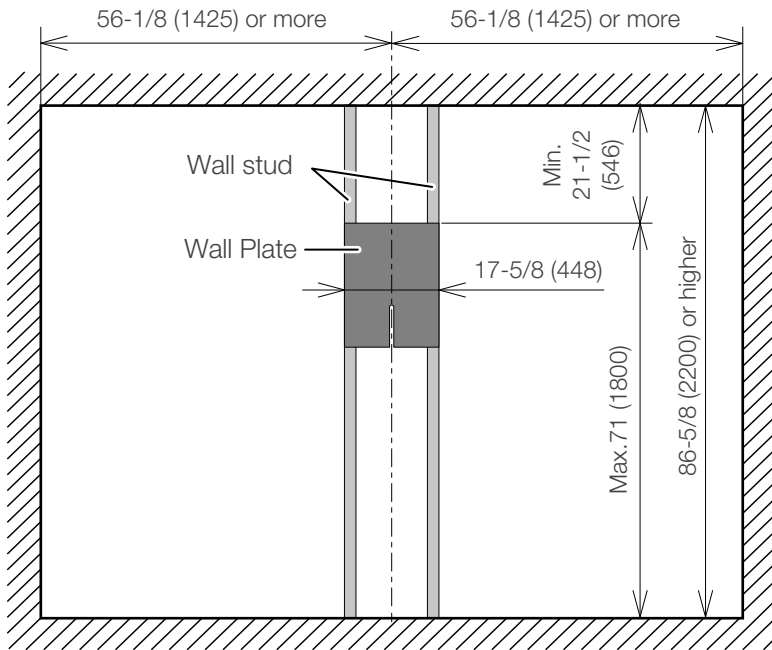

Unit: inch (mm)

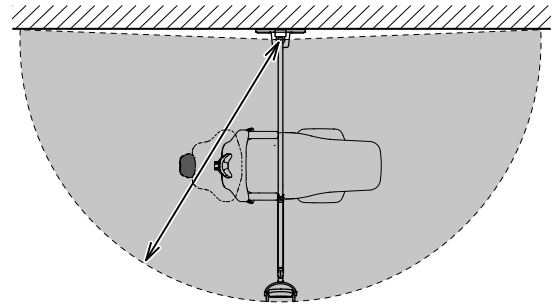

- Maximum reach of light head from center is 94-5/8 (2403)
- Position the chair and light so that when the chair backrest is recline, the light head can be brought to the patient's mouth area.

Wall Plate dimensions

Unit: inch (mm)

Drill four(4) pilot holes with 3/16" bit, depth of 2".

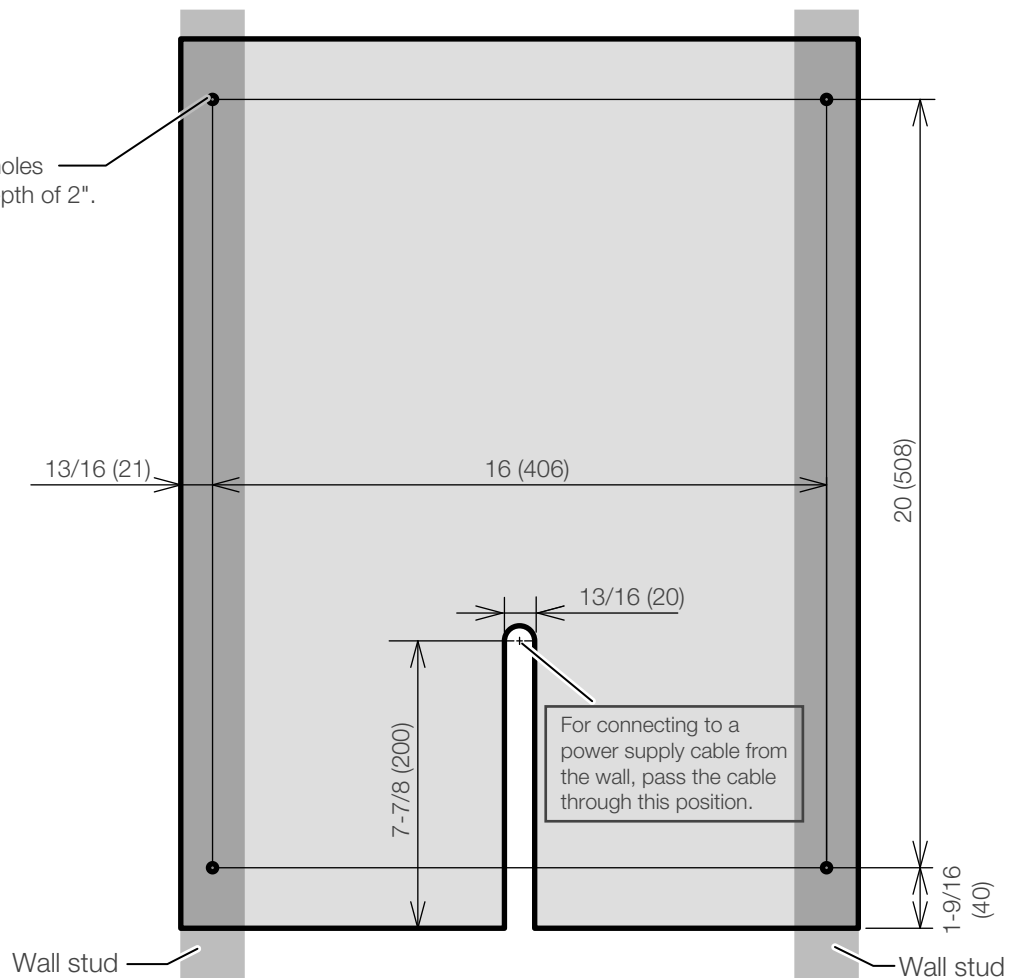

3 Installation

Necessary tools

Phillips screwdriver No. 1,2,3

Hex key wrench; width across flats: 2mm, 2.5mm, 4mm

Precaution for Installation

- (1) The light wall plate must be securely mounted to the wall studs.

DO NOT mount to metal studs.

- (2) For electrical code compliance, confirm code requirements in your area.

(1) Mounting to the wall plate

1. With a 3/16" drill, drill four pilot holes approximately 2" depth. See page 53.
2. Mount wall plate assembly to the studs, with four lag bolts and washers (supplied).
3. Remove PCB cover by removing two screws from it. This cover will be attached later on.
4. Place a level on top of pole receptacle left to right and front to back, and adjust the level with four leveling bolts.

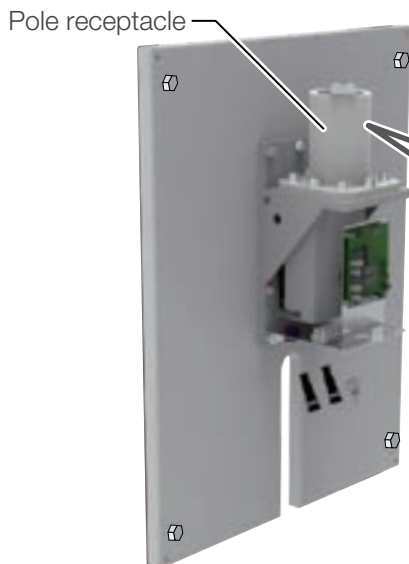
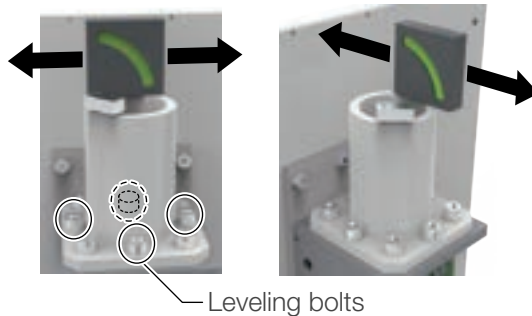
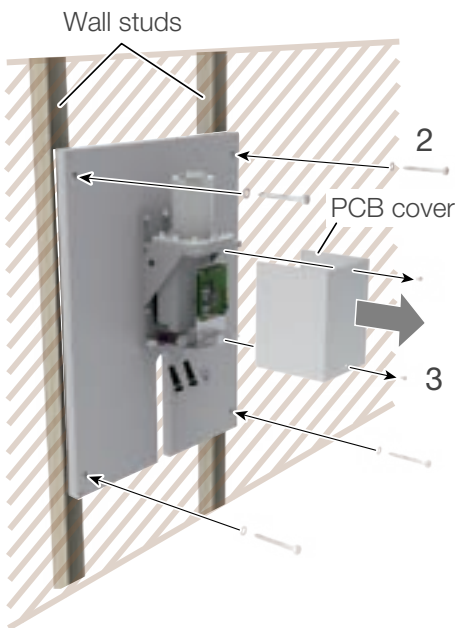

5. Remove the retainer metal from top of pole receptacle. (This metal must be installed later on)

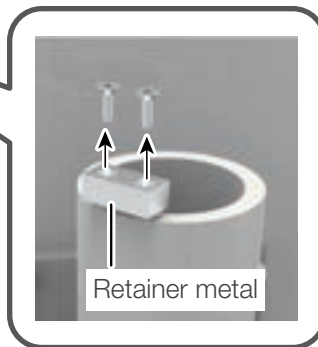

3 Installation

(2) Light Pole Mounting

1. Pass the connection cable through light pole.
2. Pass the connection cable in step 1 through the pole receptacle and attach the light pole to the pole receptacle.
To make this job easier, hold the light pole horizontally, and swing it right and left while inserting into pole receptacle.
3. Re-attach retainer metal which was removed in step 5 of (1) [page 54]

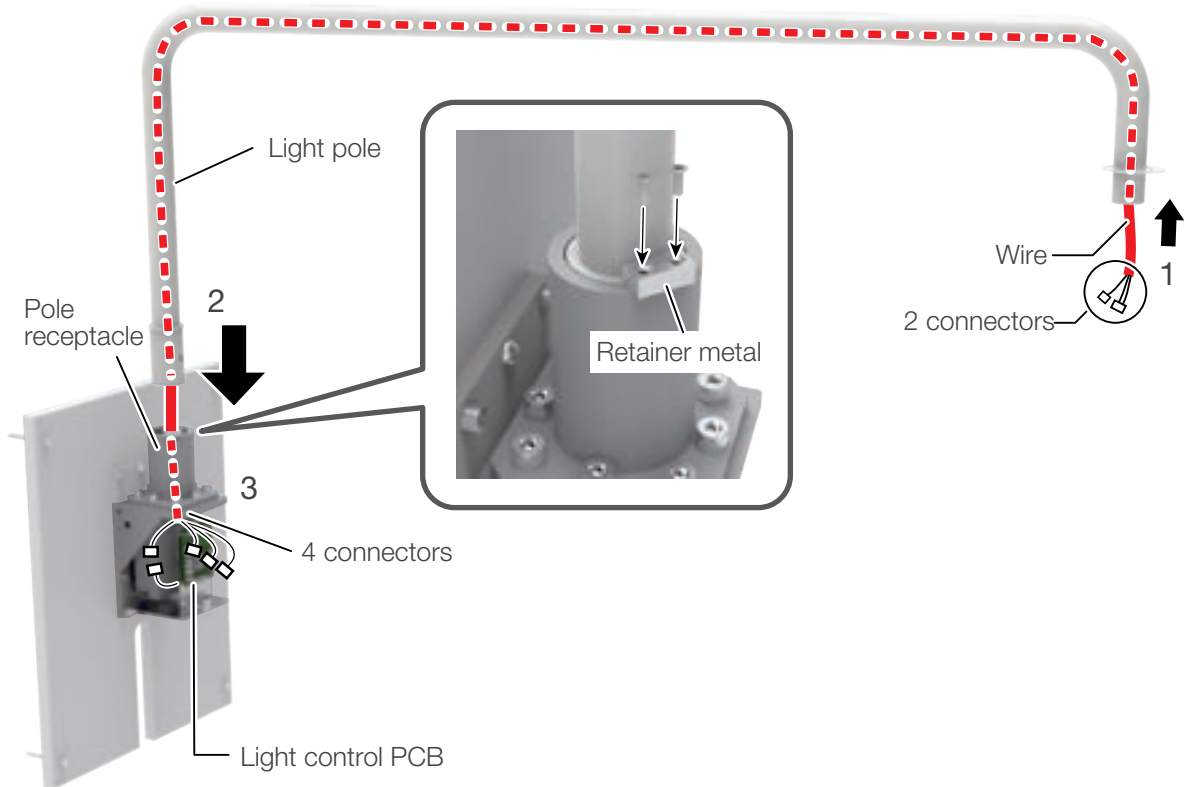

4. Connect the connector of the wire as shown in the figure.

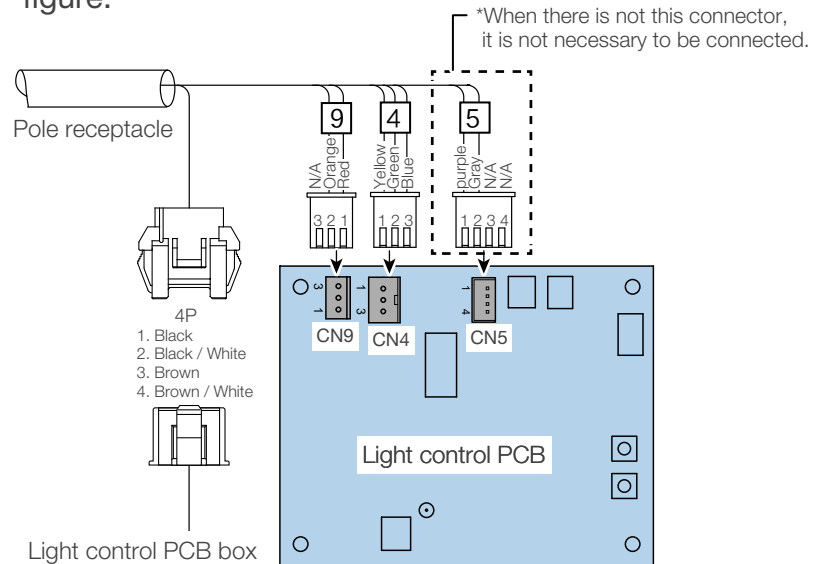

3 Installation

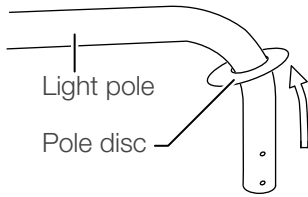

(3) Attach light assembly to light pole

1. Slide the pole disc from the end of the light pole.

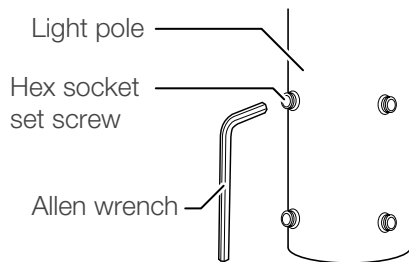

2. Loosen four (4) hex socket set screws on the light pole.
(DO NOT remove hex socket set screws).

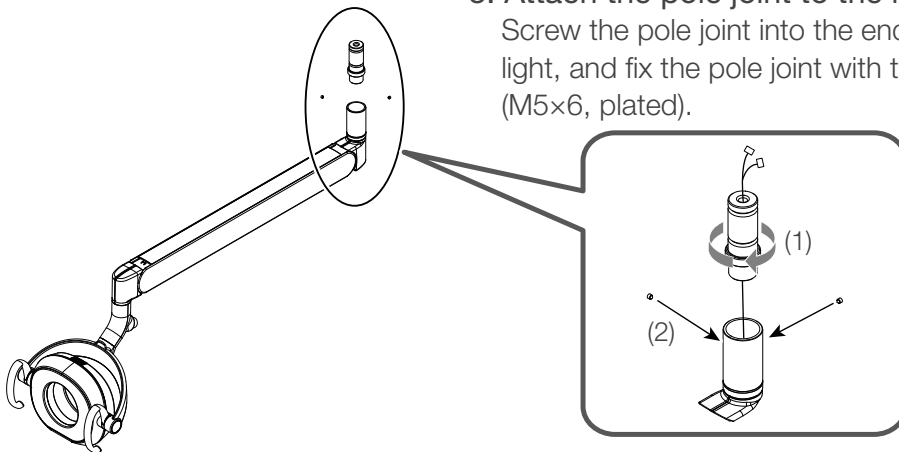

3. Attach the pole joint to the light.

Screw the pole joint into the end of the balance arm of the light, and fix the pole joint with two hex socket set screws (M5×6, plated).

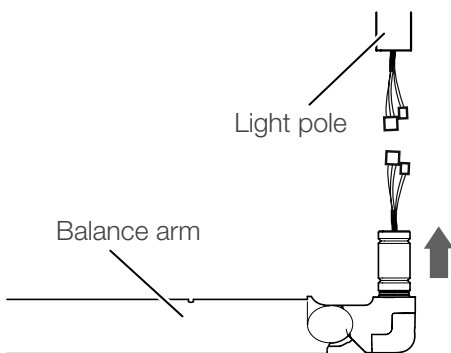

4. Attach light assembly to light pole.

(1) Join connectors from light pole to those from balance arm.

(2) Insert balance arm stem into light pole.
(If wires stick, pull wires from wall bracket inside)

(3) Tighten four hex socket set screws loosened in step 2.
These screws also limit the swing range of balance arm.

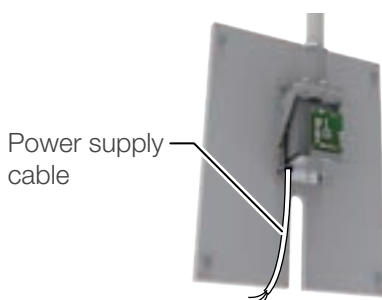

5. Connect the power supply cable of the wall plate to the power supply.

3 Installation

6. Connect 3P connector and 4P connector from plate cover to connector on wall plate assembly.
7. Re-attach the PCB cover which was removed in step 3 of (1) [page 54]
8. Place plate cover over the wall plate and secure it with tapping screws with washers supplied.

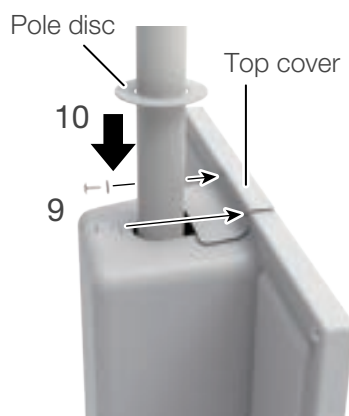
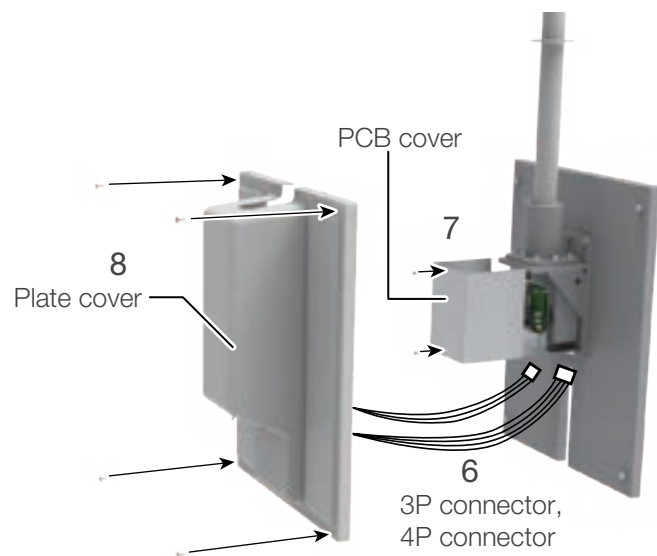

9. Attach top cover and secure it with two self tapping screws with washers supplied.
10. Slide pole disc down to cover the opening around light pole on the top cover.

3 Installation

3-3 Attaching the patient mirror



1. **Detach the back cover of the light head**
Remove the four pan head screws (M4 x 10, plated).

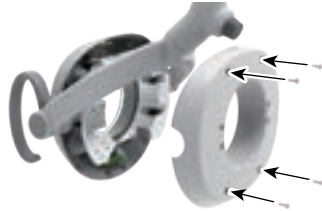

2. **Attach the back cover of the light head enclosed with the patient mirror.**
Fix it in place using the screws detached in Step 1.



3. **Insert the spacers enclosed with the patient mirror (4 pieces).**

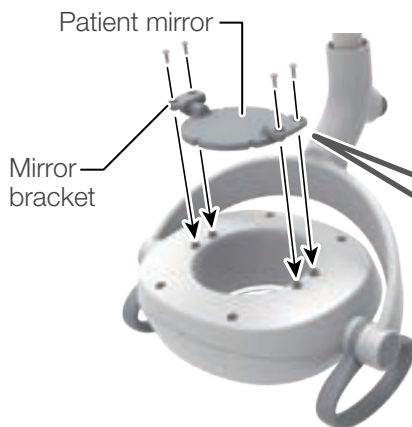

4. **Attach the patient mirror.**
Confirm the position of the wave washer as shown in the figure and fix the patient mirror with the four pan head screws (M4×10, white) enclosed with the patient mirror.

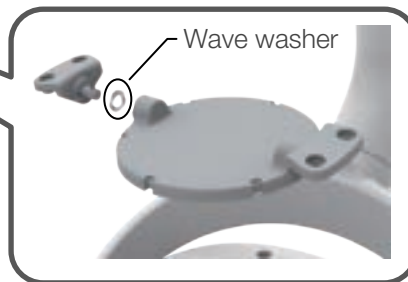

Approx. 5 degrees



*If the rotation of the mirror is too loose, tighten the screws further while pressing the both mirror brackets.

*After the attachment is completed, make sure that the mirror can be tilted and held at around 5° as shown in the figure.

5. **Confirm the raising/lowering balance of the balance arm.**

Make sure the light head stops at each position in the range of raising/lowering operation of the balance arm.

If the light head doesn't stop, refer to the "Adjusting the raising/lowering balance of the balance arm"[page 61] and adjust its balance.

3 Installation

3-4 Confirmation guideline following installation

After completing the installation process, confirm normal operation for each item below.

| Confirmation item | Check points | Confirmation method |
|-------------------------------------|---|---------------------|
| Sensor response | The light can be turned on and off by moving a hand across the perception range of the touchless switch sensor window within a distance of 2-9/16" (65 mm). | Operate the parts |
| | While the light is on, the unit can be switched between operation mode and resin mode by holding a hand for a specified time within a distance of 2-9/16" (65 mm) from the touchless switch sensor window. | Operate the parts |
| Brightness adjustment with the dial | During operation mode, the brightness can be adjusted by turning the brightness adjustment dial. | Operate the parts |
| Unit operation | The light head is retained in any position. There is no noise or looseness while operating the light head. * Following unpacking, the light head movement (vertical turn or lateral turn) may be heavy. This is normal, and the light head becomes lighter after moving it several times. | Operate the parts |

WARNING

Do not directly expose human eyes to LED light.
Exposure may hurt human eyes.

4 Adjusting the parts

4-1 Adjusting the upper limit position of the balance arm

Upper limit position of the balance arm can be adjusted 0°-30°. Upper limit position of the balance arm is set at 30° when shipped.

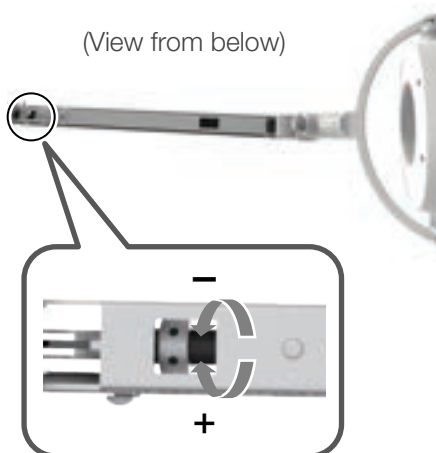
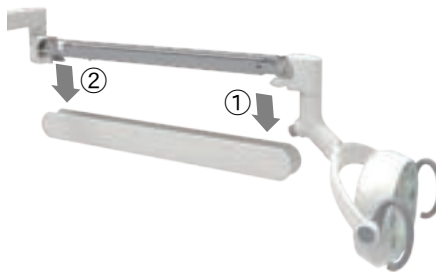
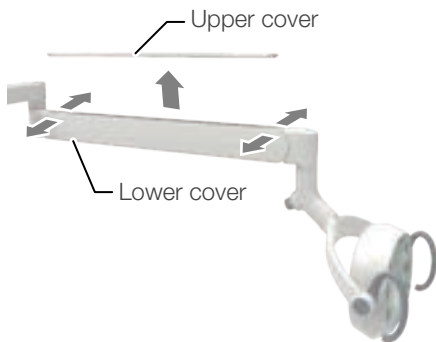

When raising the arm's upper limit position

-> Turn the nut toward the + side

When lowering the arm's upper limit position

-> Turn the nut toward the - side

1. Detach the upper cover of the balance arm

The upper cover is fixed to the lower cover of the balance arm at four points on both ends. It can be detached by lifting the end of the upper cover while opening the lower cover to left and right.

2. Detach the lower cover of the balance arm

The lower cover is fixed to the main link of the balance arm at the two projections on the left and two on the right.

- 1) First, move the lower cover downward while opening both the sides nearer the light head to the left and right.
- 2) Next, detach the lower cover by moving it downward, while opening both the sides nearer the swing arm.

3. Loosen the hex socket set screw fixed to the adjustment nut nearer the swing arm, using a hex key wrench (width across flats: 2.5 mm), and adjust the upper limit position of the arm by turning the adjustment nut using the attached adjustment rod.

Damage could result if the adjustment nut is turned without loosening the hex socket set screw.

4. Fasten the hex socket set screw after adjusting

If the hex socket set screw is not fastened, the upper limit position of the balance arm may be changed unintentionally.

5. Reattach the lower cover of the balance arm

In the reverse order of Step 2, first reattach the lower cover end nearer the swing arm, and then reattach its end nearer the light head.

In this process, confirm the indication inside the lower cover, so that the arrow "<- HEAD" points toward the light head.

6. Reattach the upper cover of the balance arm

Reattach it in the reverse order of Step 1.

4 Adjusting the parts

4-2 Adjusting the raising/lowering stiffness of the balance arm

1. Detach the upper cover of the balance arm
(See Step 1 in “Adjusting the upper limit position of the balance arm” [page 60].)

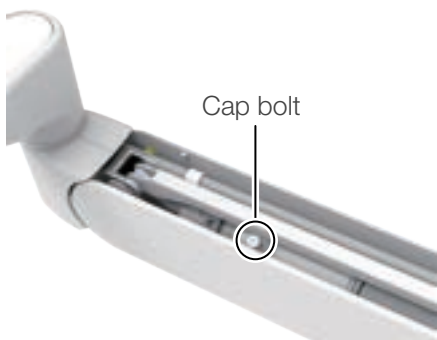

2. Adjust the raising/lowering stiffness by turning the cap bolt fixed to the shaft guide, using a hex key wrench (width across flats: 3 mm)

The movement becomes stiffer by fastening the cap bolt, and becomes less stiff by loosening it.

3. Reattach the upper cover of the balance arm.
Reattach it in the reverse order of Step 1.

4 Adjusting the parts

4-3 Adjusting the raising/lowering balance of the balance arm

1. Detach the upper cover and lower cover of the balance arm

(See Step 1,2 in “Adjusting the upper limit position of the balance arm” [page 60].)

2. Adjust the raising/lowering balance of the balance arm by turning the adjustment nut nearer the light head, using the attached adjustment rod.

When adjusting the balance arm with the jig (optional), attach the jig at the position shown in the figure below.

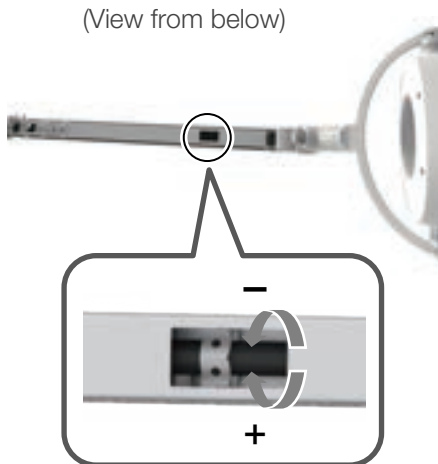

When the arm is raised excessively
-> Turn the nut toward the - side
When the arm is lowered excessively
-> Turn the nut toward the + side

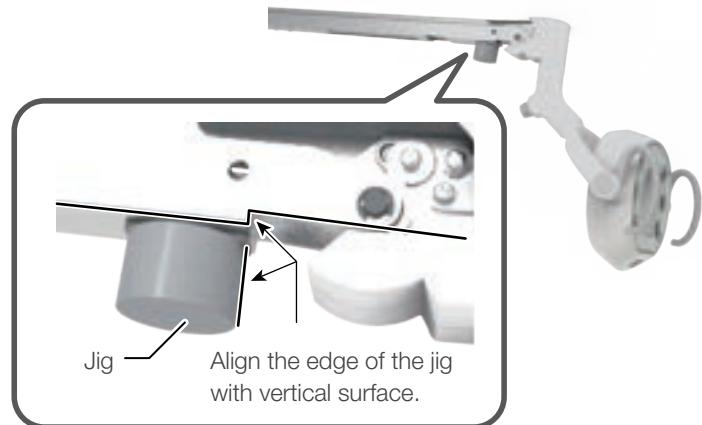

In case of adjusting the balance arm without a jig, adjust the balance arm to make it tilt slightly upward so that the arm will balance horizontally when equipped with the upper and lower covers. If the arm still doesn't balance, detach the upper and lower covers, then readjust the arm again.

3. Reattach the upper cover and lower cover of the balance arm

(See Step 5,6 in “Adjusting the upper limit position of the balance arm” [page 60].)

4 Adjusting the parts

4-4 Adjusting the turning stiffness of the balance arm

AL-D106G / AL-D109W

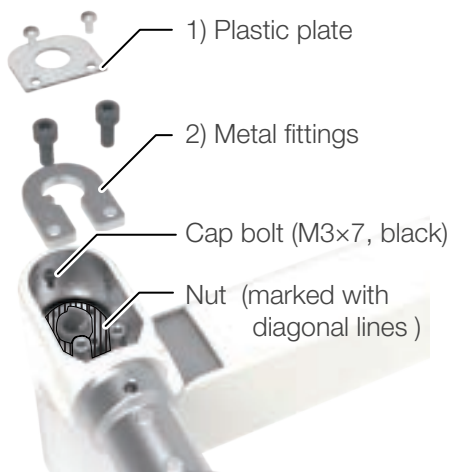
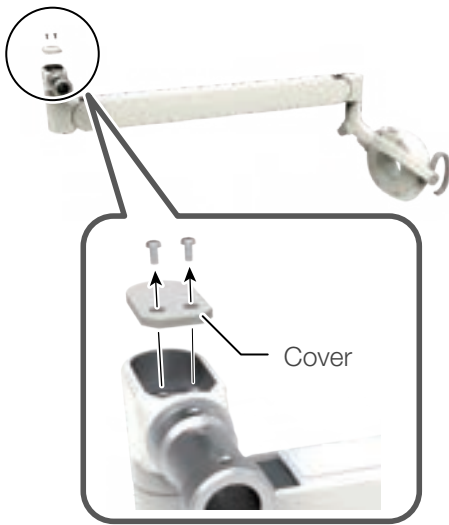

- 1. Detach the cover of the balance arm joint**
Remove the three truss head screws (M4 x 6, white).
- 2. 1) Remove the plastic plate**
Remove the two panhead screws (3P M3 x 6, SUS).
2) Remove the metal fittings
Remove the two cap bolts (M5 x 12, black).
- 3. Remove the one cap bolt (M3x7, black) fixed to the nut.**
- 4. Adjust the turning stiffness of the balance arm by turning the nut, using round nose pliers**
The movement becomes stiffer by fastening the nut, and becomes less stiff by loosening it.
- 5. Reattach the one cap bolt (M3x7, black) removed in Step 3.**
When contacting the head of the cap bolt to the nut, rotate the cap bolt three-fourths turn.
- 6. Attach the metal fittings and the plastic plate in the reverse order of Step 2.**
* Reattach the metal fittings in the same direction as before.
- 7. Reattach the cover of the balance arm joint in the reverse order of Step 1.**

5 Wiring Diagram

AL-D105G

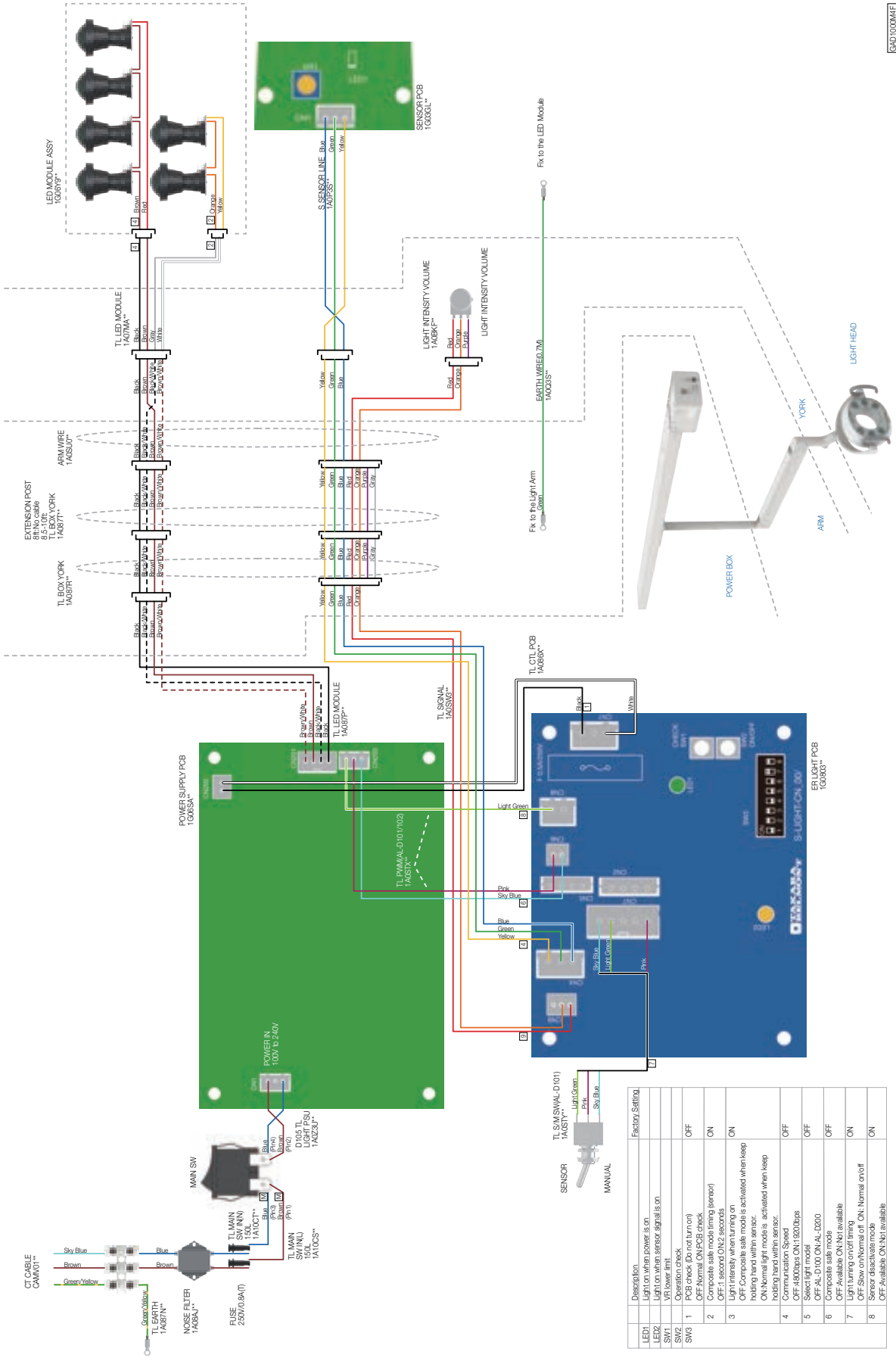

8A01000ME

| LED1 | Description | Factory Setting |
|------|---|-----------------------------------|
| LED1 | Light on when power is on | |
| SW1 | Light on when sensor signal is on | |
| SW2 | Operation check | |
| SW3 | 1 PCB check (Do not turn on) | OFF |
| | 2 Composite safe mode (liming sensor) | ON |
| | 3 Light intensity when turning on | ON |
| | 4 Composite safe mode is activation when keep holding hand within sensor | ON |
| | 5 Composite safe mode is activated when keep ON (normal light mode is activated when keep holding hand within sensor) | OFF |
| | 6 Composite safe mode | OFF |
| | 7 Light turning on/off timing | ON |
| | 8 Light on/normal or ON: Normal or off | ON |
| | | OFF: Available, ON: Not available |

5 Wiring Diagram

AL-D106G-EV (EVG OTP Unit on B50N only)

EAD1000058E

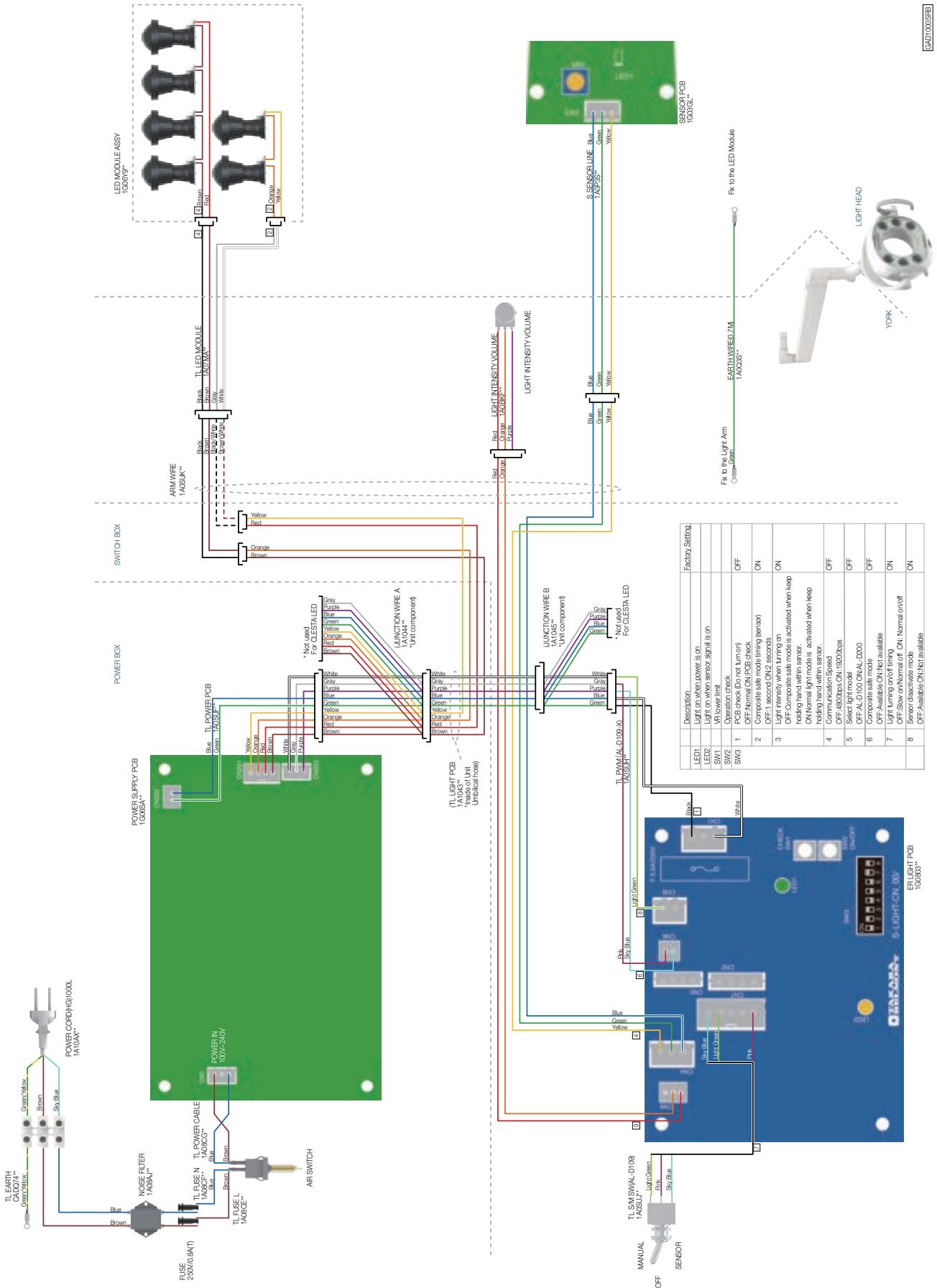

5 Wiring Diagram

AL-D106G-QU

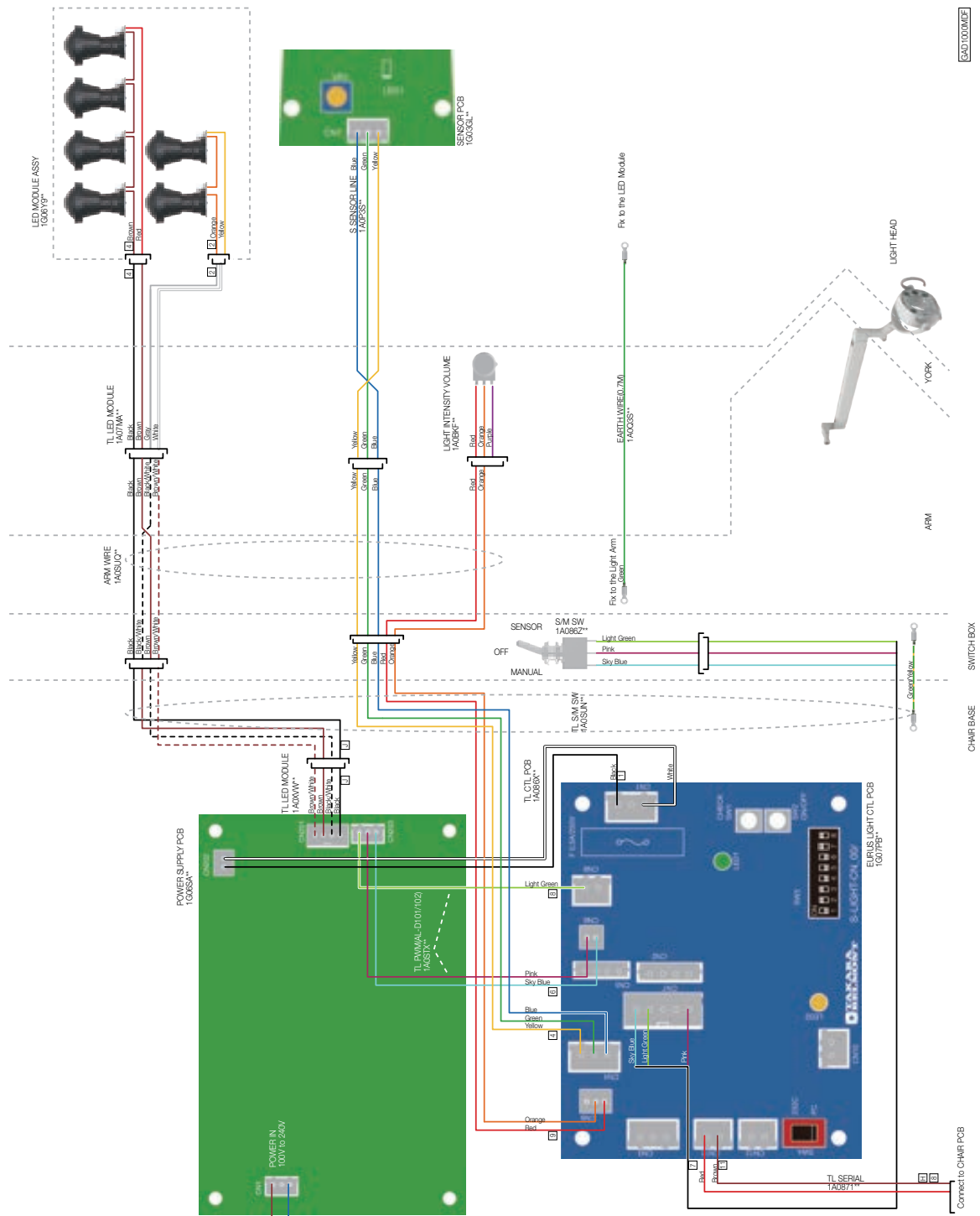

| Item | Description | Factory Setting |
|------|--|-----------------|
| LED1 | Light on when power is on | |
| LED2 | Light on when sensor signal is on | |
| SW1 | VF lower limit | |
| SW2 | Operation check | |
| SW3 | 1 Composite safe mode (turn on) 2 Composite safe mode (turn on) 3 Composite safe mode (turn on) 4 Composite safe mode (turn on) 5 Composite safe mode (turn on) 6 Composite safe mode (turn on) 7 Composite safe mode (turn on) 8 Composite safe mode (turn on) | OFF |
| SW4 | Signal type | PC |

CAD:1010MDF

CHAIR BASE SWITCH BOX

5 Wiring Diagram

AL-D107G

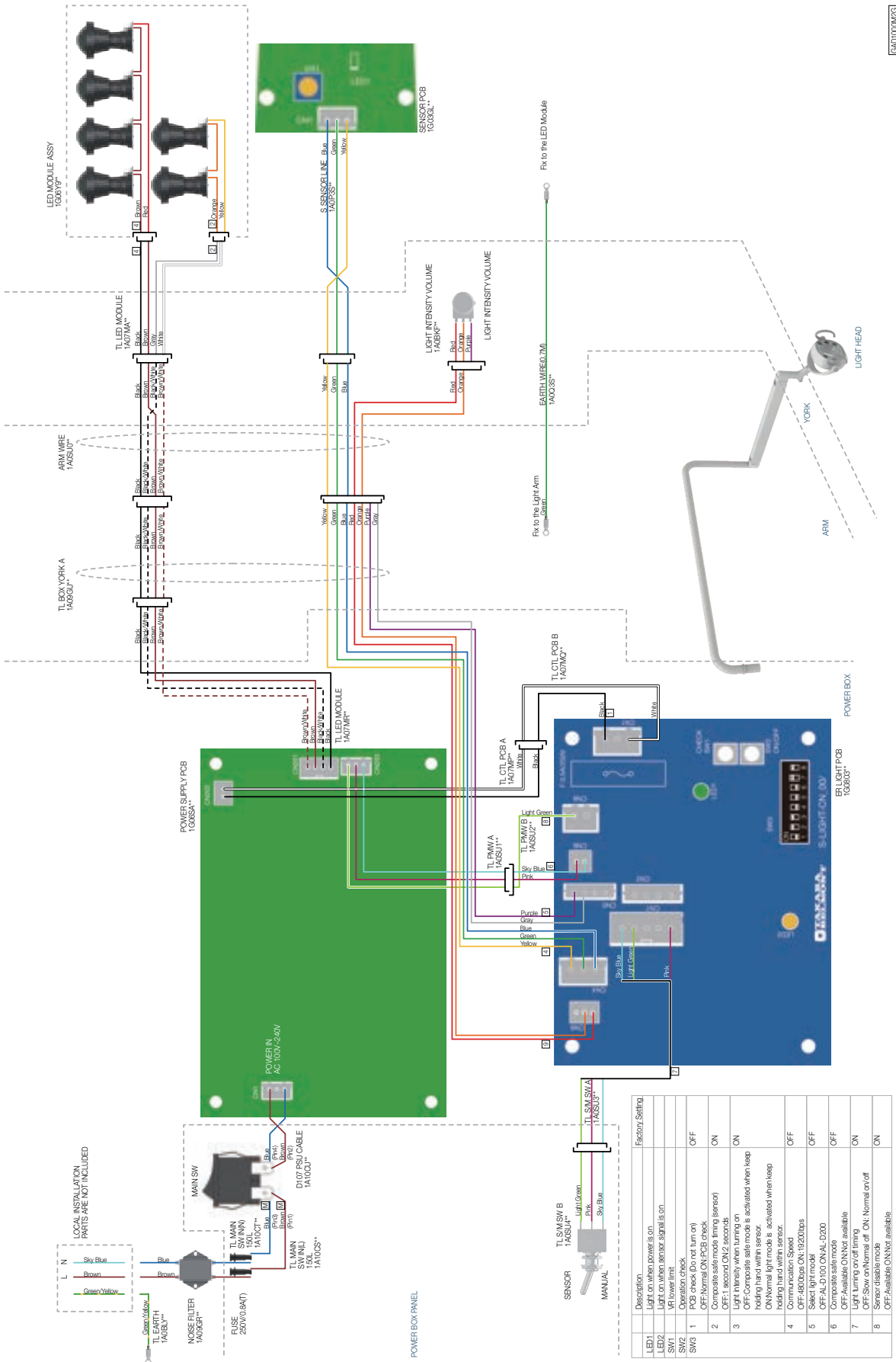

CA0100M2G3

| LED1 | Description | Factory Setting |
|------|---|--|
| LED1 | Light on when power is on | |
| SW1 | Light on when sensor signal is on | |
| SW2 | Operation check | OFF |
| SW3 | 1. PGB check (Do not turn on) 2. Composite site mode (firing sensor) | ON |
| | 3. Light intensity when turning on | OFF: 1 second ON/2 seconds |
| | 4. Composite site mode is activated when keep holding hand with sensor | OFF: Composite site mode is activated when keep holding hand with sensor |
| | 5. Communication Speed | OFF: 4800bps ON: 19200bps |
| | 6. Select light model | OFF |
| | 7. Composite site mode | OFF: Available ON/Not available |
| | 8. Light turning on/off timing | ON |
| | 9. Sensor on/off timing | ON: Normal off |
| | 10. Sensor on/off timing | OFF: Available ON/Not available |

| | |
|------------------------|----------|
| 2024-09 (10th edition) | |
| REF | 1E07PEKE |



Importer in U.S.A.
BELMONT EQUIPMENT,
Division of Takara Belmont USA, Inc.
101 Belmont Drive, Somerset, New Jersey 08873 U.S.A.
TEL : (732) 469-5000 / (800) 223-1192
FAX : (732) 356-1035

Importer in Canada
TAKARA COMPANY, CANADA, LTD.
2455 Meadowvale Blvd. Mississauga, Ontario L5N 5S2, Canada
TEL : (905) 816-8965
www.belmont.ca

TAKARA BELMONT CORPORATION
2-1-1, Higashishinsaibashi, Chuo-ku, Osaka, 542-0083, Japan
TEL : +81-6-6213-5945
FAX : +81-6-6212-3680

