

# WIRING DIAGRAM / Bel-NOVA POST MOUNT and CEILING MOUNT TYPE / AL-D101/102\*-NA

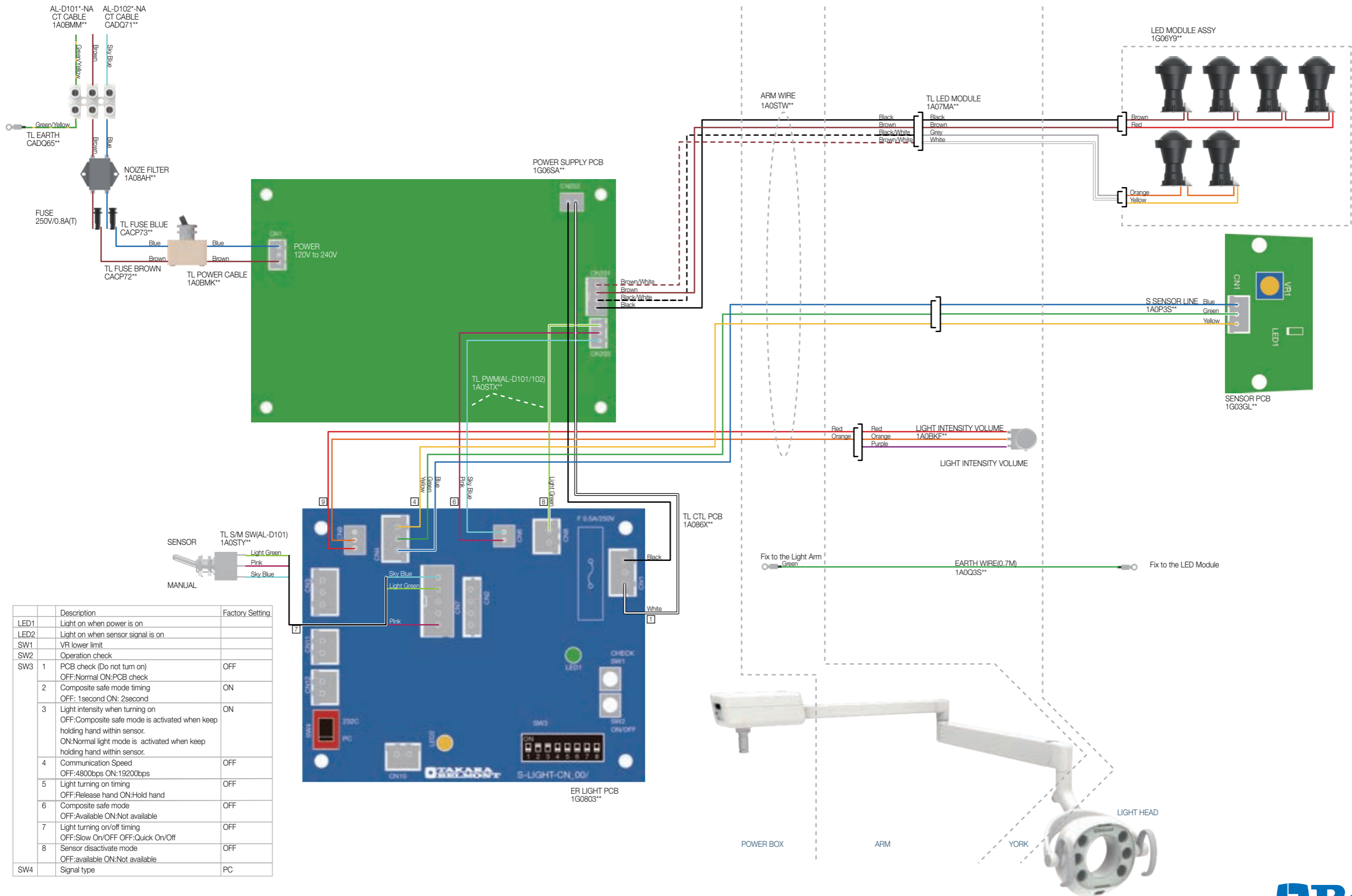

	Description	Factory Setting
LED1	Light on when power is on	
LED2	Light on when sensor signal is on	
SW1	VR lower limit	
SW2	Operation check	
SW3	1 PCB check (Do not turn on) OFF:Normal ON:PCB check	OFF
	2 Composite safe mode timing OFF: 1second ON: 2second	ON
	3 Light intensity when turning on OFF:Composite safe mode is activated when keep holding hand within sensor. ON:Normal light mode is activated when keep holding hand within sensor.	ON
	4 Communication Speed OFF:4800bps ON:19200bps	OFF
	5 Light turning on timing OFF:Release hand ON:Hold hand	OFF
	6 Composite safe mode OFF:Available ON:Not available	OFF
	7 Light turning on/off timing OFF:Slow On/OFF OFF:Quick On/Off	OFF
	8 Sensor disactivate mode OFF:available ON:Not available	OFF
SW4	Signal type	PC

\*Showing D101 TYPE

# WIRING DIAGRAM / Bei-NOVA TRACK MOUNT TYPE / AL-D105\*-NA

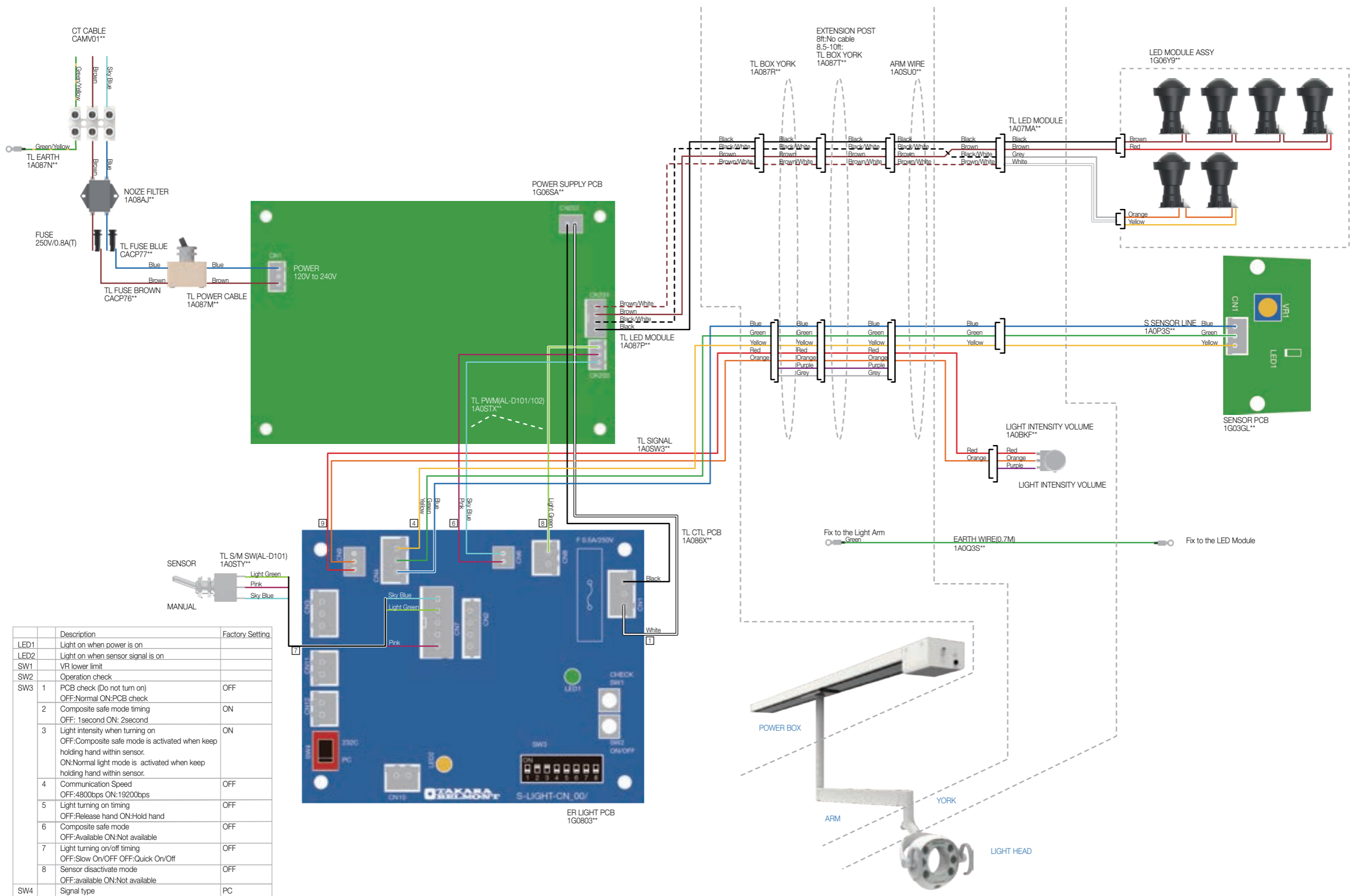

# WIRING DIAGRAM / Bel-NOVA EVOGUE and X-CALBER MOUNT / AL-D106G-EV / AL-D109W-X\*

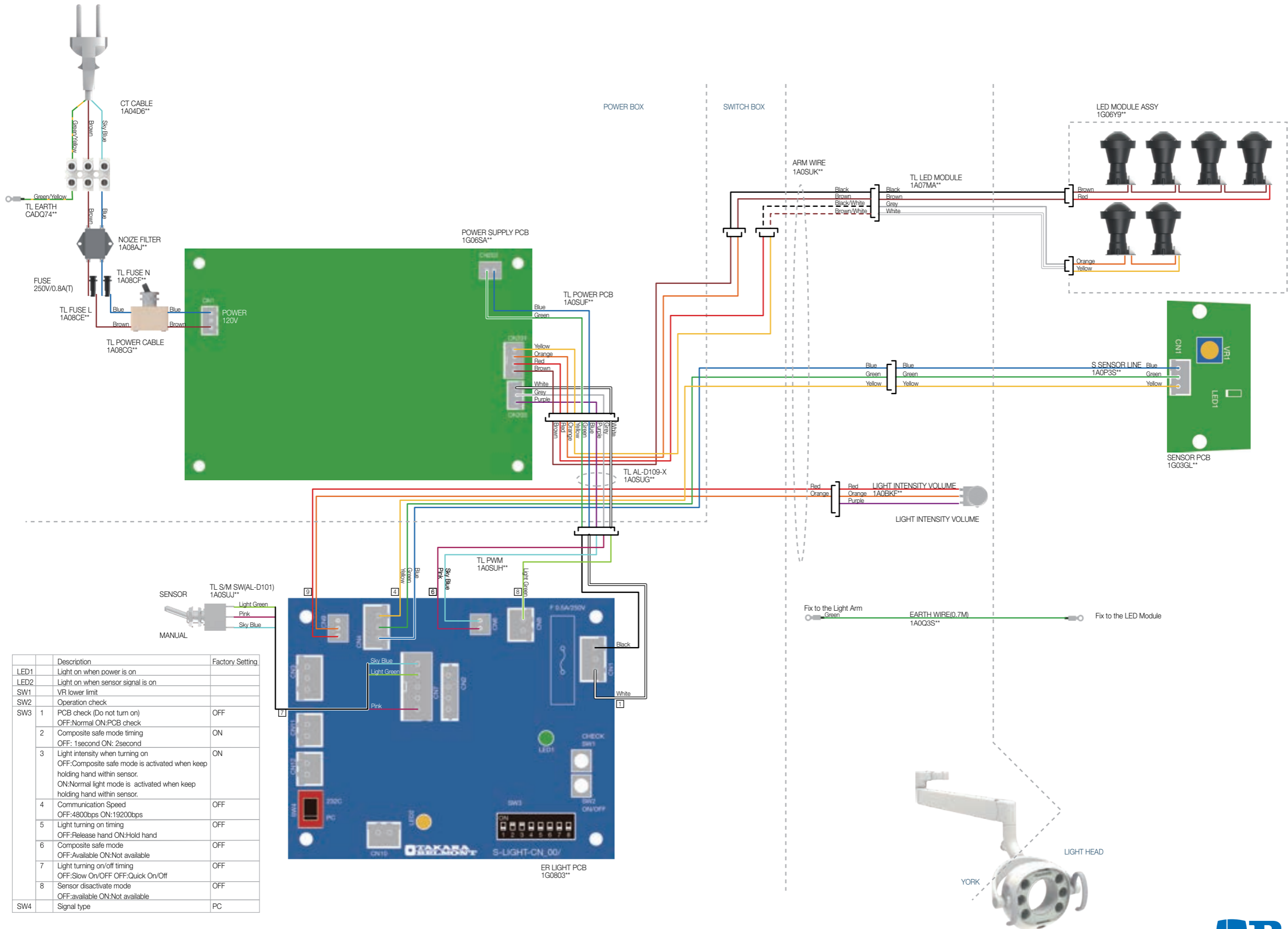

# WIRING DIAGRAM / BeI-NOVA QUOLIS MOUNT / AL-D106G-QU

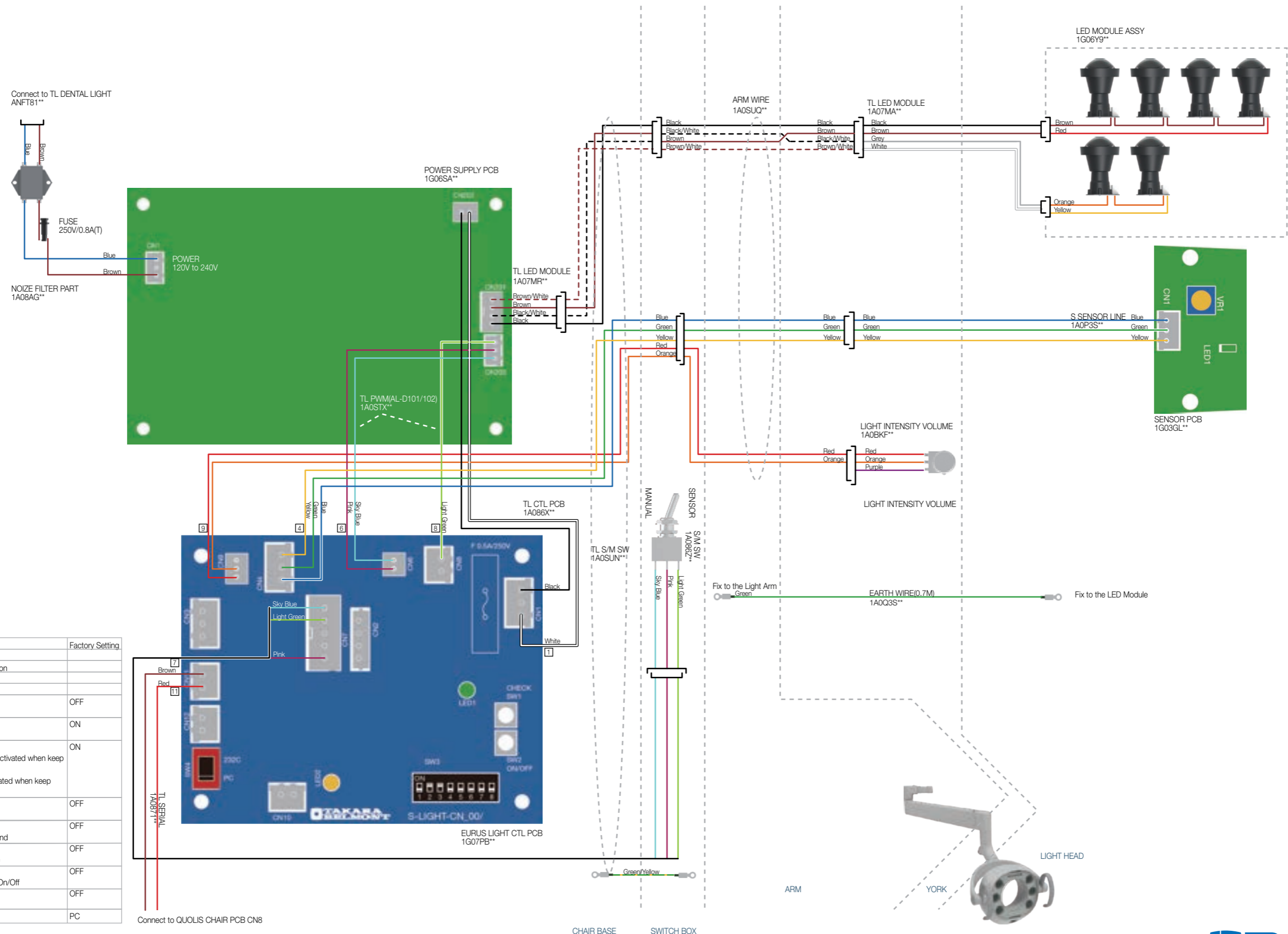

	Description	Factory Setting
LED1	Light on when power is on	
LED2	Light on when sensor signal is on	
SW1	VR lower limit	
SW2	Operation check	
SW3	1 PCB check (Do not turn on) OFF:Normal ON:PCB check	OFF
	2 Composite safe mode timing OFF: 1second ON: 2second	ON
	3 Light intensity when turning on OFF:Composite safe mode is activated when keep holding hand within sensor. ON:Normal light mode is activated when keep holding hand within sensor.	ON
	4 Communication Speed OFF:4800bps ON:19200bps	OFF
	5 Light turning on timing OFF:Release hand ON:Hold hand	OFF
	6 Composite safe mode OFF:Available ON:Not available	OFF
	7 Light turning on/off timing OFF:Slow On/OFF OFF:Quick On/Off	OFF
	8 Sensor disactivate mode OFF:available ON:Not available	OFF
SW4	Signal type	PC

# WIRING DIAGRAM / BeI-NOVA CABINET MOUNT TYPE / AL-D107\*-NA

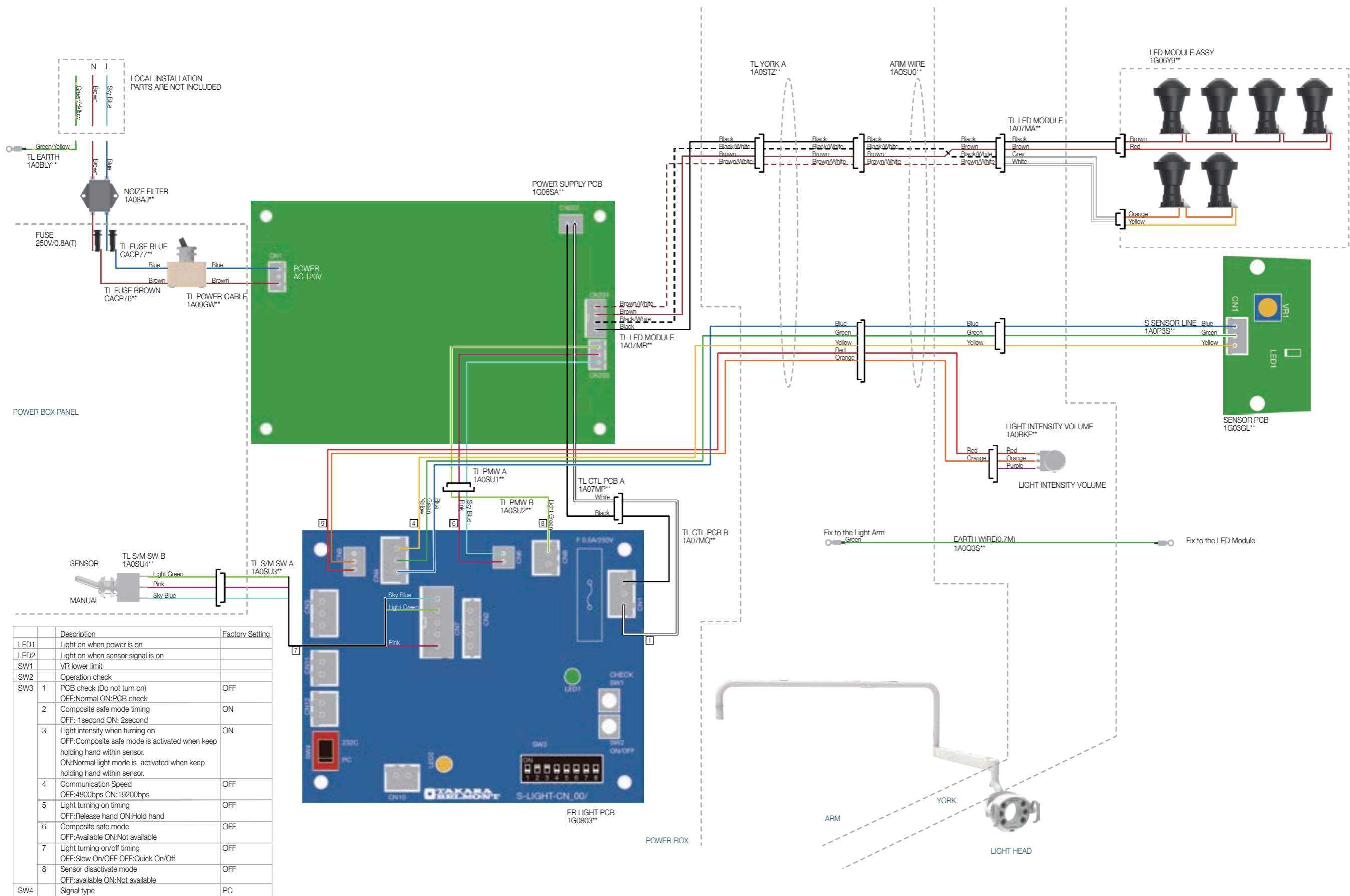

# WIRING DIAGRAM / BeI-NOVA WALL MOUNT TYPE / AL-D108\*-NA

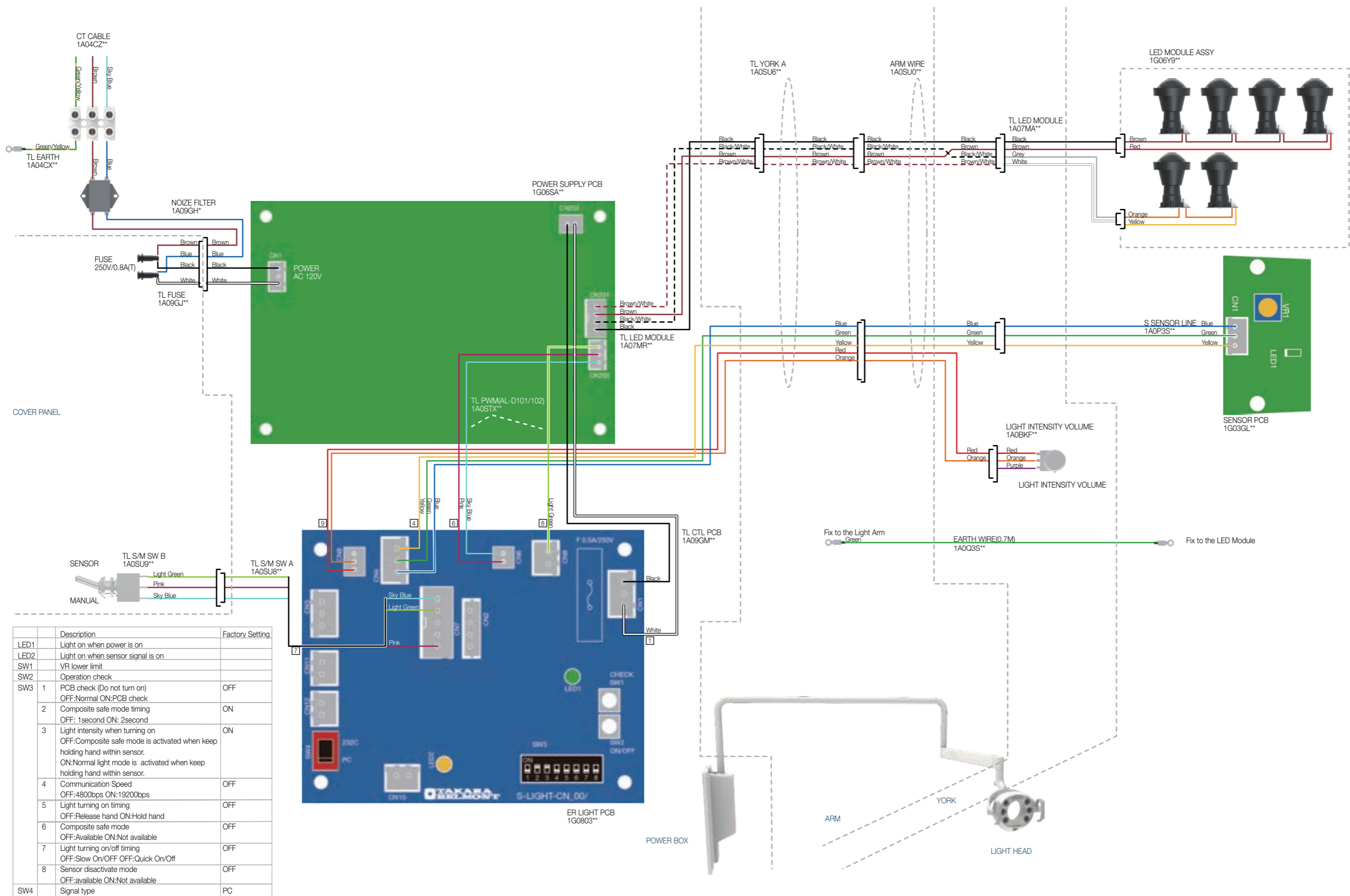

	Description	Factory Setting
LED1	Light on when power is on	
LED2	Light on when sensor signal is on	
SW1	VR lower limit	
SW2	Operation check	
SW3	1 PCB check (Do not turn on) OFF:Normal ON:PCB check	OFF
	2 Composite safe mode timing OFF: 1second ON: 2second	ON
	3 Light intensity when turning on OFF:Composite safe mode is activated when keep holding hand within sensor. ON:Normal light mode is activated when keep holding hand within sensor.	ON
	4 Communication Speed OFF:4800bps ON:19200bps	OFF
	5 Light turning on timing OFF:Release hand ON:Hold hand	OFF
	6 Composite safe mode OFF:Available ON:Not available	OFF
	7 Light turning on/off timing OFF:Slow On/OFF OFF:Quick On/Off	OFF
	8 Sensor disactivate mode OFF:available ON:Not available	OFF
SW4	Signal type	PC