

BELRAY II

MODEL 097

DENTAL X-RAY

**INSTALLATION
INSTRUCTIONS
(for USA & Canada)**

⚠ WARNING

This X-ray unit may be dangerous to patient and operator unless safe exposure factors, operating instructions and maintenance schedules are observed.

 Belmont®

 **CAUTION**

This manual provides information and instructions for the installation, assembly calibration and certification procedures for **BELMONT BELRAY II MODEL 097** dental x-ray.

The instructions contained in this book should be thoroughly read and understood by dealer service personal before attempting to install the X-ray unit. After installation is completed, owners should file this manual and refer back to it to schedule periodic maintenance.

INDEX

	PAGE
SECTION 1 : TECHNICAL DATA	
[1] ELECTRICAL AND RADIATION DATA -----	2
[2] PHYSICAL DIMENSIONS -----	3
[3] TUBE HEAD THERMAL CHARACTERISTICS -----	4
SECTION 2 : PRE-INSTALLATION INSTRUCTIONS	
[1] SUPPORT REQUIREMENTS -----	5
[2] ELECTRICAL REQUIREMENTS -----	5
[3] LOCATION OF COMPONENTS -----	6
SECTION 3 : INSTALLATION INSTRUCTIONS	
[1] INSTALLATION REQUIREMENTS -----	7
[2] UNPACKING -----	7
[3] MAIN CONTROLLER AND ARM INSTALLATION -----	8
[4] HEAD ASSEMBLY INSTALLATION -----	13
[5] SUB CONTROLLER INSTALLATION -----	15
[6] HAND EXPOSURE SWITCH (OPTION) -----	16
[7] EXTERNAL INTERLOCKS (NOT SUPPLIED) -----	16
SECTION 4 : POST INSTALLATION INSPECTION	
[1] ARM ASSEMBLY -----	17
[2] BALANCE ARM TENSION ADJUSTMENT -----	17
[3] HEAD POSITIONING -----	17
SECTION 5 : CONTROL IDENTIFICATION AND OPERATION	
[1] MAJOR COMPONENTS AND CONTROL IDENTIFICATION -----	18
[2] FUNCTION OF CONTROLS -----	19
[3] OPERATING PROCEDURES -----	21
[4] ESTIMATED AIR KERMA-----	21
[5] OPTIONAL HAND EXPOSURE SWITCH -----	21
[6] ERROR CODES -----	22
[7] MAINTENANCE -----	23
SECTION 6 : POST INSTALLATION CONFIRMATION	
[1] CONFIRMATION OF POWER SUPPLY VOLTAGE -----	24
[2] CONFIRMATION OF TUBE CURRENT -----	24
[3] CONFIRMATION OF EXPOSURE WARNING LAMP & BUZZER -----	25
[4] CONFIRMATION OF LINE VOLTAGE REGULATION -----	25
SECTION 7 : INITIAL SETTING	
[1] SPEED SETTING FOR FILM AND DIGITAL IMAGING -----	26
[2] PRIORITY OF SELECTIONS -----	29
[3] ELECTRONIC CHIME ON/OFF -----	29
[4] ESTIMATED AIR KERMA DISPLAY SETTING-----	29
APPENDIX 1 : PARTS IDENTIFICATION	
[1] ARM AND HEAD ASSEMBLY -----	30
[2] CONTROLLER ASSEMBLY -----	31
APPENDIX 2 : CIRCUIT DIAGRAM -----	32
APPENDIX 3 : CERTIFICATION -----	33

SECTION 1 : TECHNICAL DATA

[1] ELECTRICAL AND RADIATION DATA

1. X-ray tube Canon D-0712 (Stationary Anode)
 - a. Nominal focal spot value 0.7 (IEC60366)
 - b. Target material Tungsten
 - c. Target angle 16°
 - d. Maximum anode heat content 4.3kJ (6kHU)
2. Maximum x-ray tube assembly heat content 150kJ (210kHU)
3. Rated peak tube potential 70 kVp
4. Rated tube current 4 mA / 7 mA selectable
5. Maximum rated peak tube potential 70 kVp
6. Rated line voltage 120 V AC, 60Hz , Single Phase,
12 VA (Long term rating)
0.8 kVA (Momentary rating)
7. Line voltage range 108 V AC ~ 132 V AC
8. Range of line voltage regulation 0 ~ 3 %
9. Rated line current..... 6.5 A at 70 kVp, 7 mA
10. Maximum line current 7.2 A at 70 kVp, 7 mA
11. Exposure time 0.02 ~ 3.2 sec.(ON and OFF are zero crossed)
12. Inherent filtration 1.7 mm Al Equivalent
13. Added filtration 0.5 mm Al
14. Minimum filtration permanently in useful beam 2.2 mm Al Equivalent at 70 kVp
15. Nominal roentgen output

	4mA	7mA
a. Distal end of regular cone	4.2	7.1 mGy/sec. ± 40 %
b. Distal end of long cone	1.9	3.3 mGy/sec. ± 40 %

(Data obtained by direct measurement in the useful beam)
16. Nominal electrical output of H. V. Generator..... 0.36kW at 70kVp, 7mA
17. Cone

	Source to skin distance	Field size
a. Regular cone	8 inches (204 mm)	58 mm dia., circular
b. Long cone (option)	12 inches (305 mm)	58 mm dia., circular
18. Maximum symmetrical radiation field 60 mm dia. at distal end of cone
19. Leakage technique factor 70 kVp / 0.14 mA
(0.14 mA is maximum rated continuous current for 7 mA with a duty cycle 1: 50)
20. Duty cycle 1: 50 (0.5 sec. exposure with 25 sec. interval)
21. Maximum deviation of tube potential, tube current and exposure time
 - a. Below 0.1sec. setting ± 10 kVp, ± 2 mA, ± 1pulse
 - b. 0.1sec. setting & up ± 8 kVp, ± 1 mA, ± 1pulse
22. Measurement base of technique factors
 - a. peak tube potential Peak tube potential of conducting half cycle
 - b. tube current Average of tube current during one cycle of line frequency
 - c. exposure time Impulses of power line frequency
23. Half value layer 1.5 mm Al over
24. Source to the base of cone distance 81 mm
25. Environmental condition for storage -20 ~ 70°C, 10 ~ 100%, 500 ~ 1060hPa
26. Environmental condition for operation 10 ~ 40°C, 30 ~ 70%, 700 ~ 1060hPa

[2] PHYSICAL DIMENSIONS

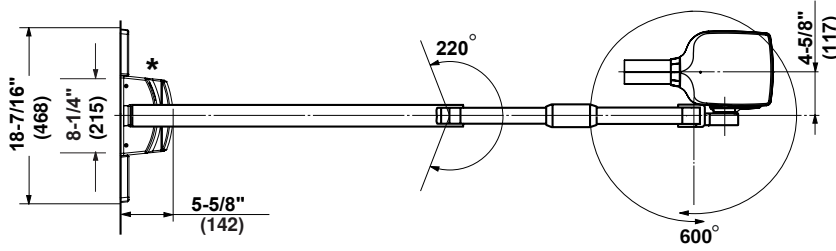

() =mm

* 8-1/4" (215 mm) is the Pass-Thru Plate Width, if Optional 097PTP is ordered and Housing Side Panels are Removed.

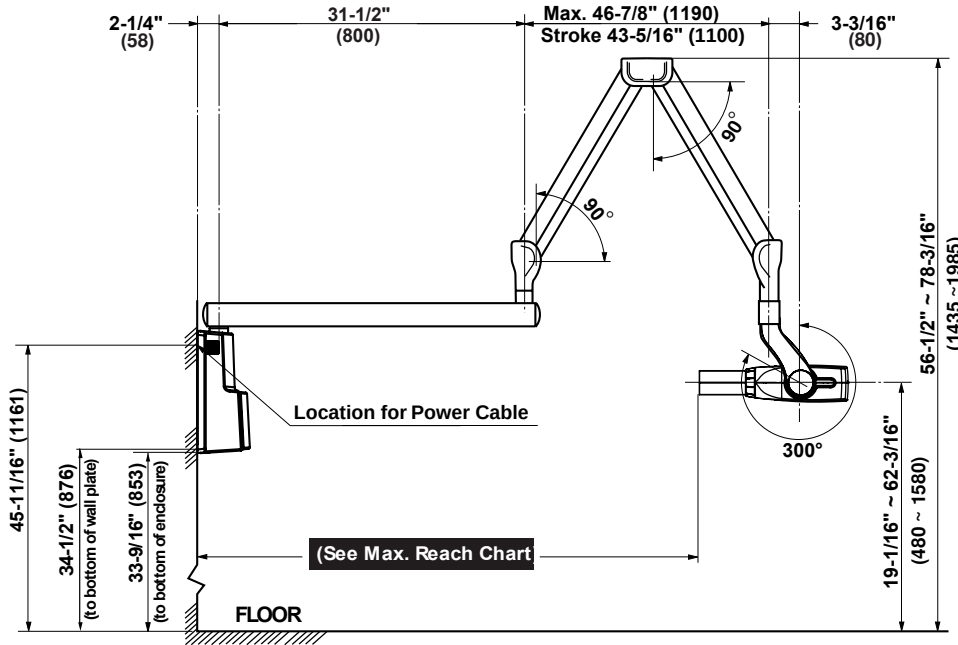

Maximum Reach

81-5/8" (2057)	with 40.0" (1000)
73-1/8" (1857)	with 31.5" (800)
61-5/8" (1557)	with 20.0" (500)
53-5/8" (1357)	with 12.0" (300)

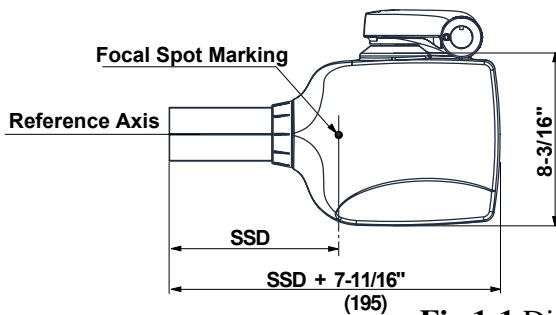
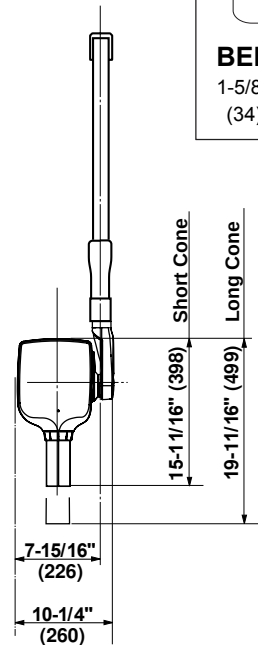
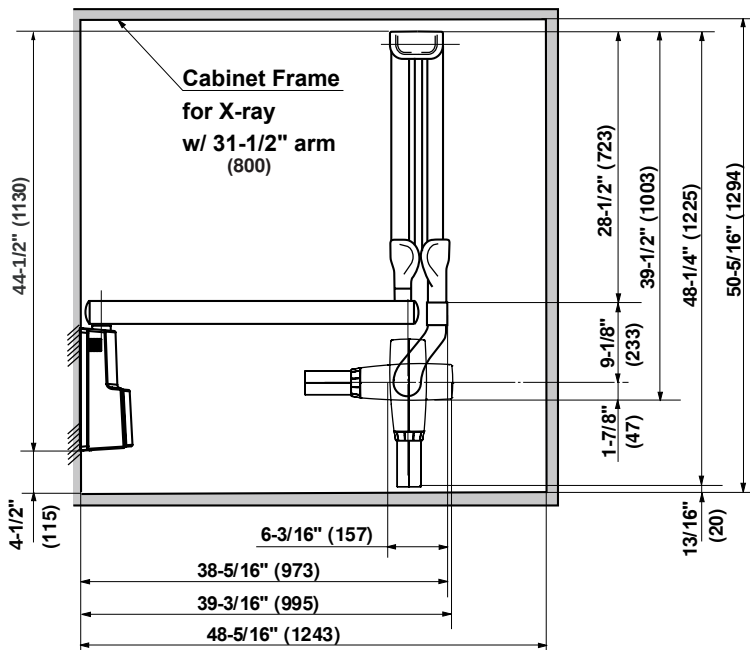
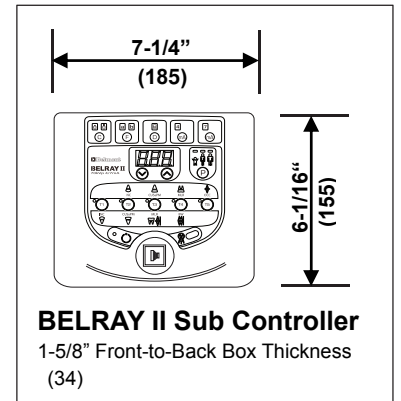

SSD (Source to Skin Distance):

- Regular cone ----- 8 inches (204 mm)
- Long cone ----- 12 inches (305 mm)

Fig.1-1 Dimensions

[3] TUBE HEAD THERMAL CHARACTERISTICS

A. Interval between each exposure

The temperature inside of the tube head rises when an exposure is made. The value of the heat generated is measured in Heat Units (HU), which is the product of tube potential, tube current and exposure time. Excessive heat will accumulate inside of the tube head if the x-ray is used without a proper cool down interval between each exposure. The excessive heat may damage the x-ray tube, high voltage generator or both.

B. Duty cycle

A cool down interval of 50 seconds or more must be allowed between each 1 second exposure. (a 25 second cool down must be allowed between each 0.5 second exposure.) This will avoid the accumulation of excess heat and prolong the tube head life.

C. Tube head cooling curve

1. Tube housing cooling curve

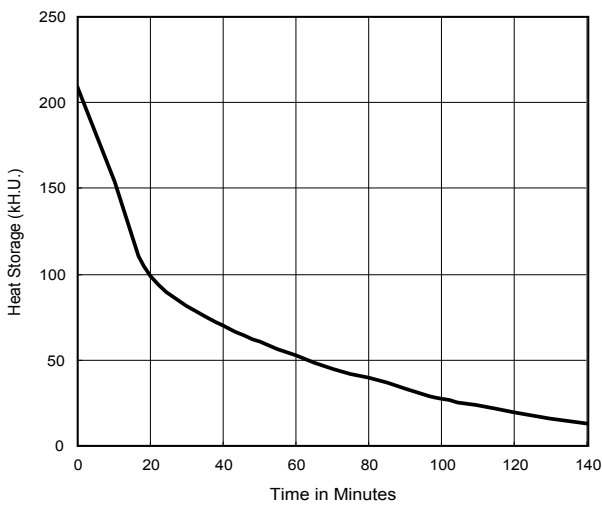

2. Anode thermal characteristics

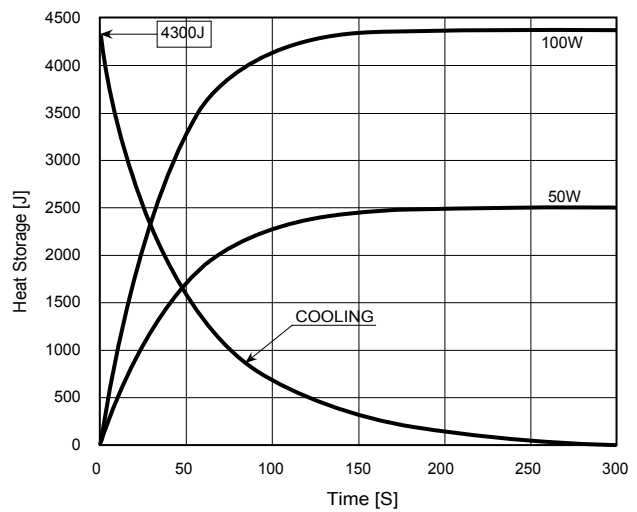

3. Maximum rating chart

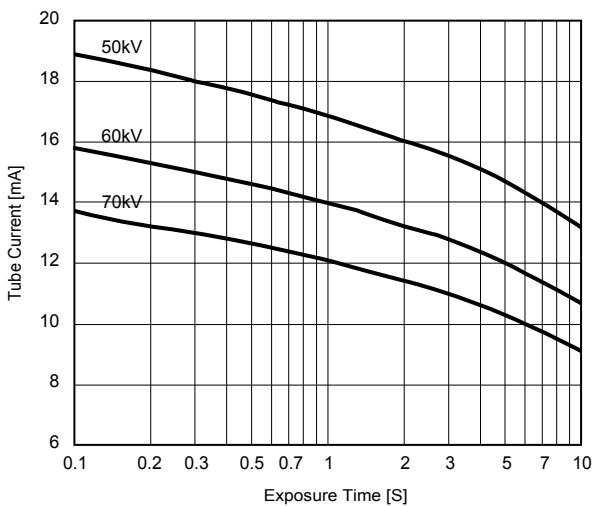

SECTION 2 : PRE-INSTALLATION INSTRUCTIONS

[1] SUPPORT REQUIREMENTS

Main Controller :

The main controller of model 097 has a wall plate designed for mounting on two 2" x 4" wood studs with 16 inches (406mm) centers. The wall and mounting hardware must be sufficient to withstand a **100 pound (45kg) shear load and a 450 pound (205kg) withdrawal force** at each of the four (ø 9 x 75mm) lag screws.

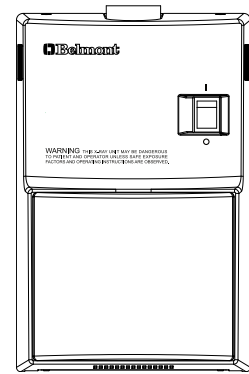

Fig.2-1 Main Controller

Sub Controller :

When mounting the model 097 sub controller, the wall and mounting hardware must be sufficient to withstand a **10 pound (4.5kg) shear load**.

⚠ CAUTION

If the BELRAY II Model 097 is to be mounted in a manner other than what is specified in this manual or if the hardware to be used is other than what is supplied, the support capability of the wall and the strength of the hardware must be checked and verified to be adequate.

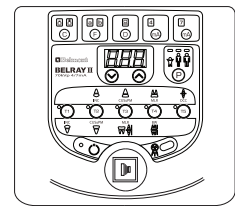

Fig.2-2 Sub Controller

[2] ELECTRICAL REQUIREMENTS

Power supply :

The model 097 x-ray system will operate on a power supply of 120VAC \pm 10% (108 ~ 132V AC) with a 3-wire GROUNDED circuit. It is recommended to be separately connected to the central distribution panel with an over-current protection device rated for 16 amperes. Recommended wire size is 14 AWG, but if the wire run distance exceeds 50 feet (15m), 12 AWG is required. For wire run distance more than 75 feet (23m), 10 AWG is required. Line voltage regulation must be within 0 ~ 3 % at 6.5 amps.

Interconnecting wiring between main controller and sub controller :

4 conductors, 20 AWG, 300V, 33 feet (10m) cable is included.

Concealed wiring :

Route conduit and wires through wall and into (2) flush mounted junction boxes located (1) behind the main controller and (1) behind the sub controller. Recommended heights above the finished floor for the flush junction boxes are : 44-7/8" (1140mm) for the main controller and 51-5/8" (1310mm) for the sub controller. Wiring done in this manner should extend 12 inches (300mm) beyond the wall surface to allow sufficient wire for connections.

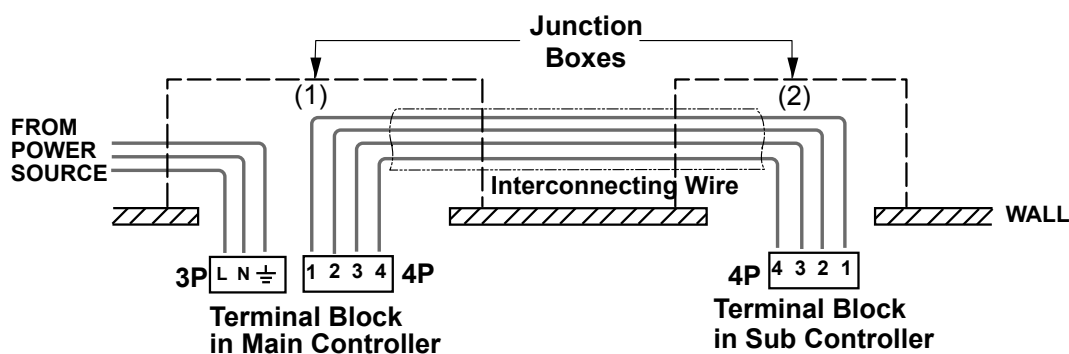

Fig.2-3 Concealed Wiring

Note : Follow local and national electrical code (NFPA 70) requirements during installation.

[3] LOCATION OF COMPONENTS

A. Main Controller, Arm and Head Assemblies :

Using the information Provided in Fig.2-4, determine the correct location for the main controller.

NOTE : State and local requirements supersede guide lines indicated below.

() : WITH LONG CONE

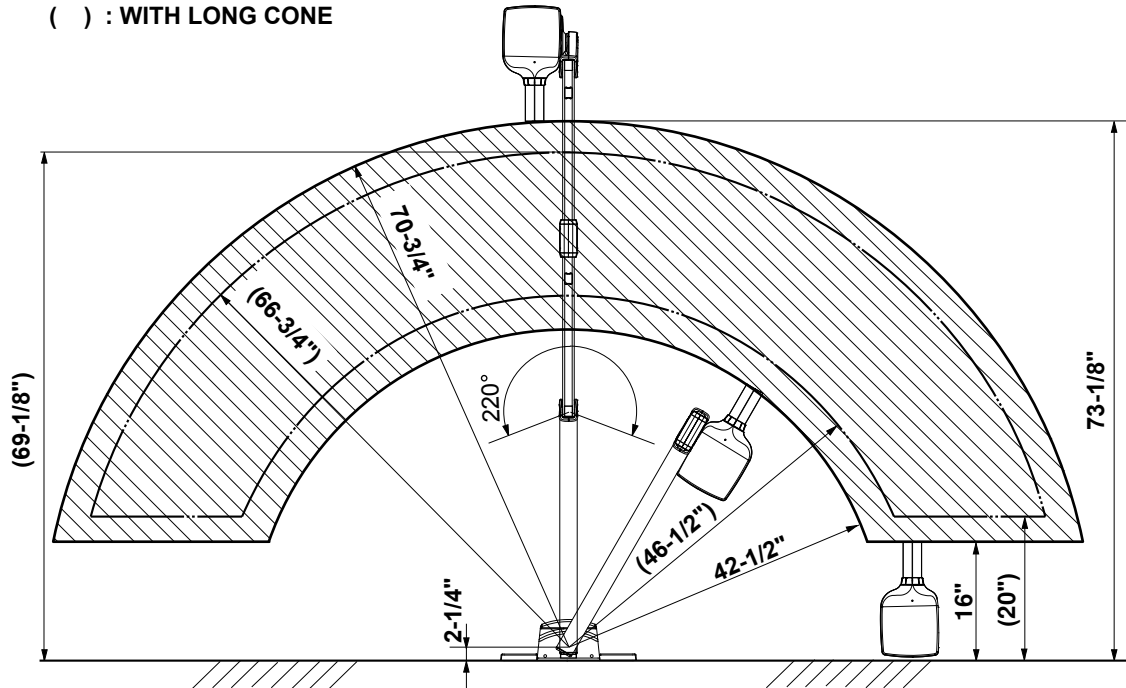

Fig.2-4 Radius of Activity for X-ray Head

B. Sub controller

When determining the location for the sub controller, the following radiation requirements concerning the operator's positioning must be considered.

The operator must :

1. have full view of the patient.
2. have means for audio and visual communication with the patient.
3. have full view of kV, mA, timer selections and exposure warning light.
4. be at least 2 m away from the x-ray head and patient and out of the path of the x-ray beam or be positioned behind a protective device.

SECTION 3 : INSTALLATION INSTRUCTIONS

Within the installation and confirmation procedures are inspection/test steps which the installer must perform to insure that the installation meets the manufacturer's specifications. These steps require the installer to record the necessary information onto the "ASSEMBLER'S INSTALLATION SECTION OF THE LIMITED WARRANTY REPORT FORM" supplied, which **MUST** be returned to BELMONT along with the warranty card.

[1] INSTALLATION REQUIREMENTS

Tools :

Standard tool kit including 1.5 mm, 2 mm, 3 mm and 5 mm allen keys.

Instruments :

- Digital multimeter with an accuracy of 1%, capable of measuring 150 V AC and 10 mA DC, and capable of indicating true RMS value within 1 sec.
- Standard calculator.

Power Supply :

Prior to starting the installation, inspect the power supply and confirm that it is 120 V AC \pm 10%, and a 3-wire GROUNDED circuit. It is recommended to be separately connected to the circuit breaker panel with an over-current protection device rated for 16 A. (Refer to Page 5, [2])

Record the voltage reading of power supply on "Assembler's Installation Report".

[2] UNPACKING

Unpack the entire contents of the shipping carton. Included within the shipping carton are :

<u>Hardware</u>	<u>Quantity</u>
Head with Regular Cone -----	1
Main Controller -----	1
Screw for chassis (M4 x 10 mm) -----	4
Screw for chassis (M4 x 6 mm) -----	1
Stopper Ring -----	1
Wall Plate -----	1
Side Cover -----	2
Hooks -----	4
Countersunk Screws (M4 x 6 mm) -----	2
Lag Screws for wall plate (ϕ 9 x 75 mm) -----	4
Arm Mounting Bracket -----	1
Machine Bolt (M8 x 20 mm) -----	3
Washer (M8) -----	3
Sub Controller -----	1
Sub Controller Mounting wood screw (ϕ 4.1 x 20 mm) -----	4
Sub Controller Mounting screw (M3 x 6 mm) -----	4
Head key -----	1
Arm collar -----	1
Balance Arm -----	1
Balance Arm Wrench -----	1
Horizontal Arm W/2 x End Caps -----	1
Screw Cover -----	2
Brake Screw (M6 x 6 mm) -----	2
Brake Spring (ϕ 5 x 15 mm) -----	2
Brake Plug (Brass Plug ϕ 5 X 4 mm) -----	2
Retaining Bolt (M6 x 35 mm) -----	2
Stopper Screw (M6 x 15 mm) -----	1
Shims -----	6
<u>Documentation</u>	<u>Quantity</u>
Installation manual -----	1
Operator's manual -----	1
Limited Warranty / Report Form -----	1
Wall mounting Template -----	1

Inspect contents of shipping carton for damage or missing components.

[3] MAIN CONTROLLER AND ARM INSTALLATION

The instructions given below are for mounting the main controller assembly on two 2 x 4 wood studs with 16 inch (406mm) centers. Should the BELRAY II MODEL 097 be mounted in a manner other than what is specified here, the wall and the strength of the hardware used must be checked and verified as being adequate to withstand a 100 pound (45kg) shear load and a 450 pound (205kg) withdrawal force at each of the four (ø9 x 75mm) lag screws. When using concealed wiring, a flush mounted junction box with the necessary conduit and wiring must be pre-installed at 44-7/8 inches (1140mm) from the floor and between the two studs (refer to wall mounting template).

A. WALL PLATE OF MAIN CONTROLLER

⚠ WARNING

Make sure the power supply is turned OFF at the circuit breaker panel.

1. Tape the wall mounting template to the wall, positioning it so that the holes for mounting plate lag screws are aligned with the vertical 2 x 4" studs.

NOTE : Confirm that the location of concealed wiring matches to the access hole of wall plate template.

2. Mark the hole locations for the mounting plate lag screws.
3. Use a 3/16" (5mm) dia. drill to make a pilot hole approximately 2" (50mm) deep for each mounting plate lag screws.

⚠ CAUTION

Do not use a drill larger than 3/16" (5mm) dia. for these holes.

4. Place the wire through the hole into the stud mount wall plate and mount the plate to the stud with the four (ø9 x 75mm) lag screws.
DO NOT FULLY TIGHTEN.

⚠ CAUTION

Be careful not to mount the wall plate backward

5. Hold the plate firmly against the wall, place a level across the front face. (#1 position in Fig.3-1)
If the wall is not plumb, use shims behind the plate to level.

6. Place a level across top edge of wall plate, level and tighten lag screws securely. (#2 position in Fig.3-1)

NOTE : Final leveling of wall plate is described on page 17.

B. ARM MOUNTING BRACKET

1. Using three (M8 x 20mm) bolts with washers in top mounting holes and in lower mounting hole, mount arm mounting bracket to wall plate. (Fig.3-2)

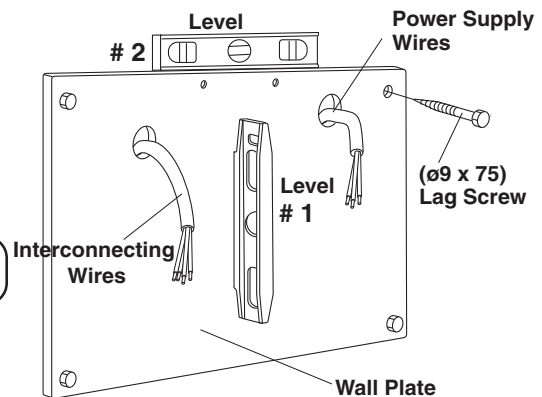

Fig.3-1 Wall Plate Installation

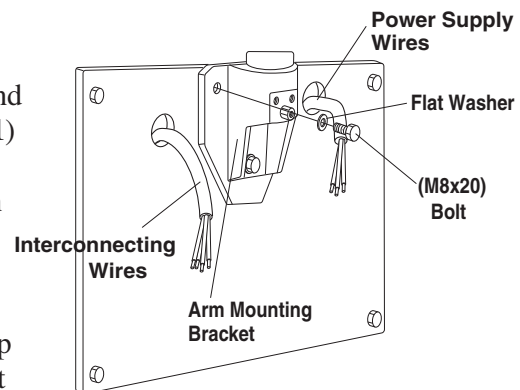

Fig.3-2 Arm Mounting Bracket Installation

C. HORIZONTAL ARM

1. Place a thrust washer over the hole on top of the arm mounting bracket.
Insert the cable of horizontal arm into the hole, and mount to the arm mounting bracket, as shown in **Fig.3-3**.

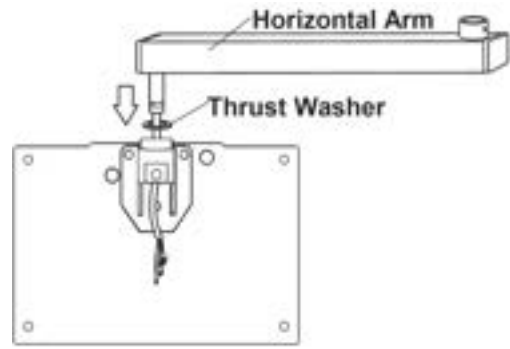

Fig.3-3 Horizontal Arm Installation

2. Insert two retaining bolts into the upper threaded holes of the arm mounting bracket and tighten securely with a Allen wrench. (**Fig.3-4**)

IMPORTANT :

The retaining bolts must be installed to ensure that the horizontal arm can not lift out of the arm mounting bracket.

3. Insert brake plug, brake spring and brake screw (M6 x 6 mm) into the threaded hole of the hex fitting located on the arm mounting bracket. **DO NOT FULLY TIGHTEN.** (**Fig.3-4**)

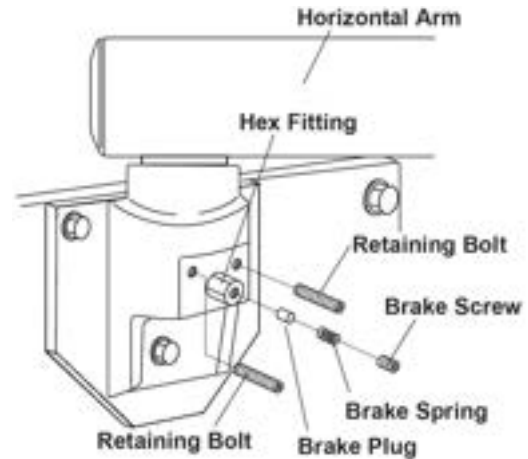

Fig.3-4 Horizontal Arm

4. Place a level on the horizontal arm and confirm that the arm has same positive degree at its left, center and right swing positions. (**Fig.3-5A**)

NOTE :

Arm level will have a minor positive degree to compensate for the head and arm weight.

- a. To make the angles at left and right positions equal, loosen two top mounting bolts slightly and move the arm brackets to the left or right.
- b. If the angle in the center position is different from the angle at the left and right positions, place the shims supplied between the arm bracket and the wall plate to adjust the angle. (**Fig. 3-5B**)

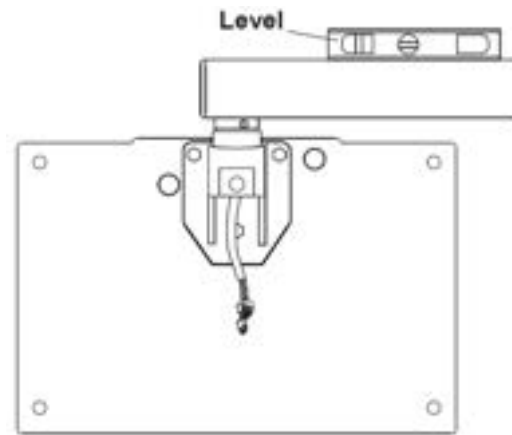

Fig.3-5A Level Check

- b-1. Insert the shim at the bottom mounting bolt if the horizontal arm tip is low.
- b-2. Insert the shims at the top two mounting bolts if the arm tip is high.

Use more than one shim on the same bolt according to the degree of angle to be corrected.

NOTE :

When using the shim, insert the shim so that the bolt is located inside of the slit of the shim and deeply as the bend of the shim touches the edge of the arm bracket.

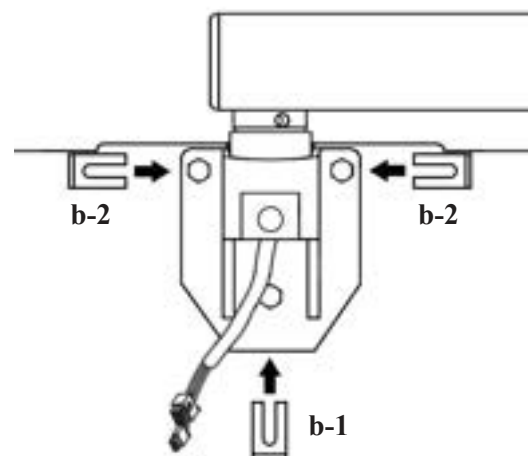

Fig.3-5B Shims

D. CHASSIS OF MAIN CONTROLLER

1. Remove the restriction plate over the terminal blocks by taking out two (M 4 x 8mm) screws. **(Fig.3-6)**
2. Route electrical interconnecting wires and power supply wires through the access holes on chassis and mount the chassis on the arm bracket with three of four (M4 x 8mm) screws. (A screw at lower right corner should be secured with a green wire from arm as setp 6. on this page.) Secure the bottom corner of chassis with two (M4 x 8mm) screws to the wall plate. **(Fig.3-6)**

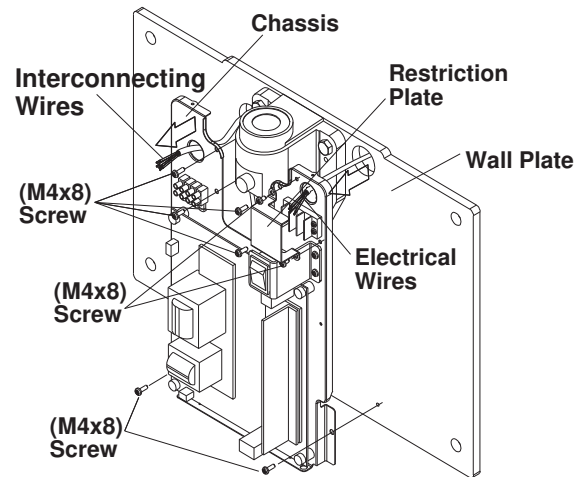

Fig. 3-6 Attaching Chassis to Wall Plate

3. Cut the wires to workable length and strip 3/8" of insulation for power supply wires and 3/16" for interconnecting wires for Sub Controller. Connect power supply wires to **3P** terminal block and interconnecting wires to **4P** terminal block. **(Fig.3-7)**

4. Reattach the restriction plate. **(Fig.3-7)**

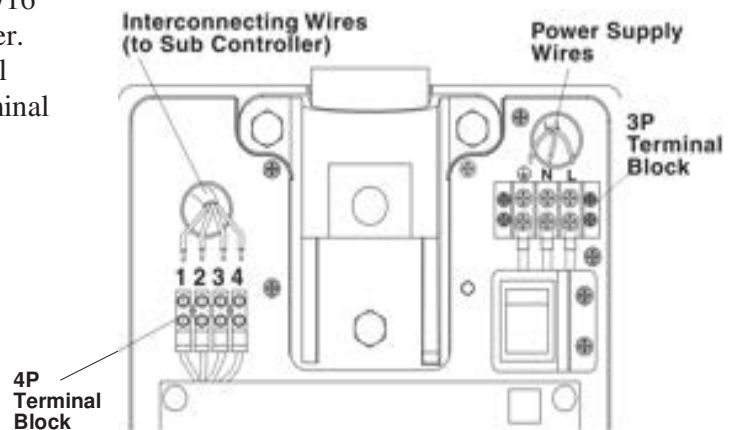

Fig. 3-7 Wires Connection in Main Controller

5. Connect 2P and 8P connectors of horizontal arm cable to the respective connectors on power PC Board. **(Fig.3-8)**

6. Secure the green wire of arm cable by a lower right corner screw of four screws securing chassis to the arm bracket.

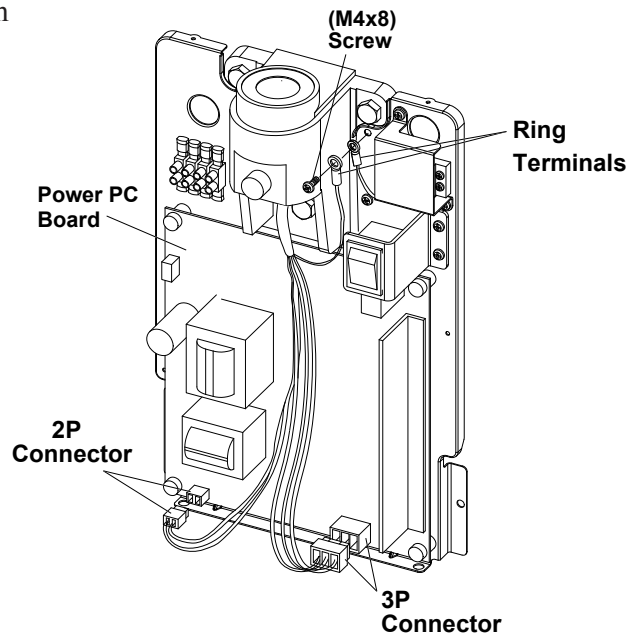

Fig. 3-8 Connecting 2P and 8P Connectors

E. FRONT COVER

NOTE : The front cover for the main controller should not be closed until all installation and the post-installation inspections and confirmation are completed.

1. Set the pins located on the bottom of the front cover into holes on the bottom of metal chassis, and then push the top side toward the wall to close. (Fig.3-9A)

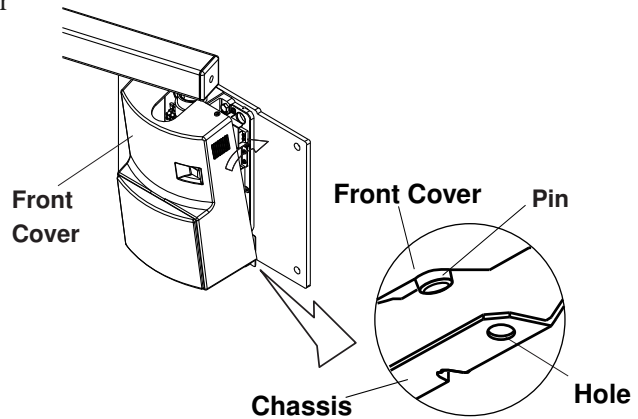

Fig. 3-9A Setting front cover on chassis

2. Install two (M3 x 8mm) screws into the top of the cover and confirm that the cover is securely attached. (Fig. 3-9B)

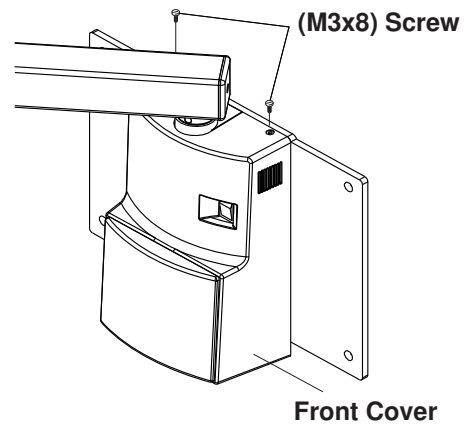

Fig.3-9B Attaching Front Cover

F. SIDE COVER

1. After the front cover of the main controller is installed, attach four hooks to the wall plate with (M4 x 6mm) screws supplied.
2. Slide in the side cover from right and left side of the wall plate as the hooks catch the side covers. (Fig.3-10)

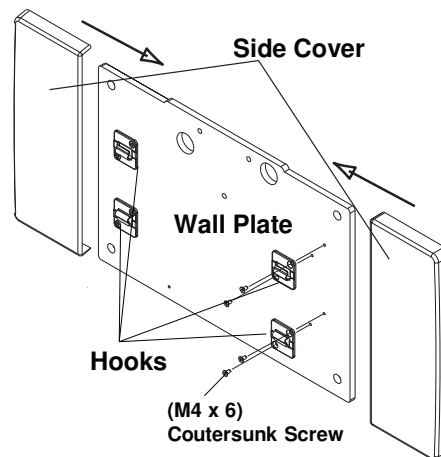

Fig.3-10 Side Cover Installation

G. BALANCE ARM ASSEMBLY

⚠ WARNING

Do not release Arm holding band until the X-ray head has been installed.
Balance arm assembly is spring loaded and can cause equipment damage and injury, if not handled in the proper manner.

1. During this procedure, do not remove Arm holding band.
2. Remove two (M3 x 8mm) screws from the underside of the horizontal arm to open the bottom cover. (Fig.3-11)
3. Route the cable with 8P connectors from the balance arm shaft through the horizontal arm. Insert the balance arm into the horizontal arm. The cable should be fed through the bottom cover opening on the bottom of the horizontal arm. (Fig.3-12)
4. Connect 8P connector of the balance arm cable to 8P connector of the horizontal arm cable. Secure the wires from the balance arm to bottom cover with a nylon cable clamp to prevent the damage from twisting. (Fig.3-13)
5. Re-attach the bottom cover to the horizontal arm with two screws. (Fig. 3-12)

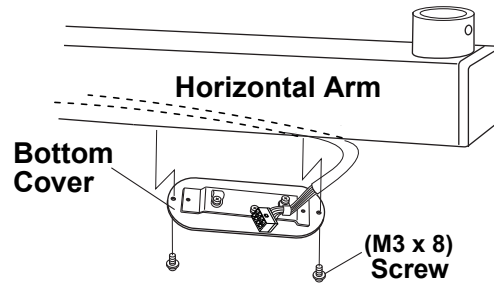

Fig.3-11 Horizontal Arm Bottom Cover

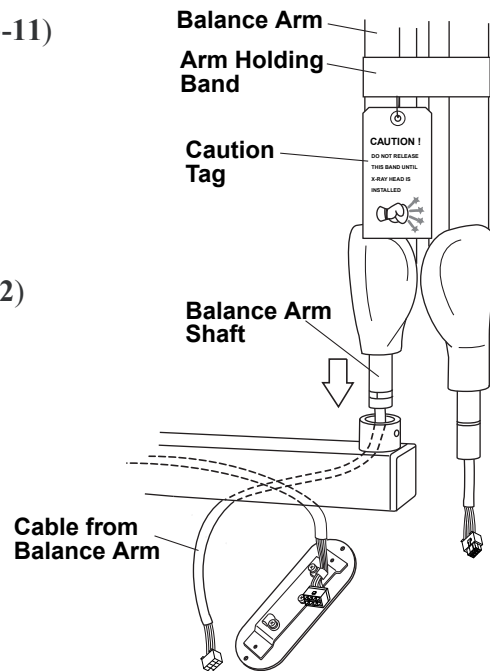

Fig.3-12 Balance Arm Installation

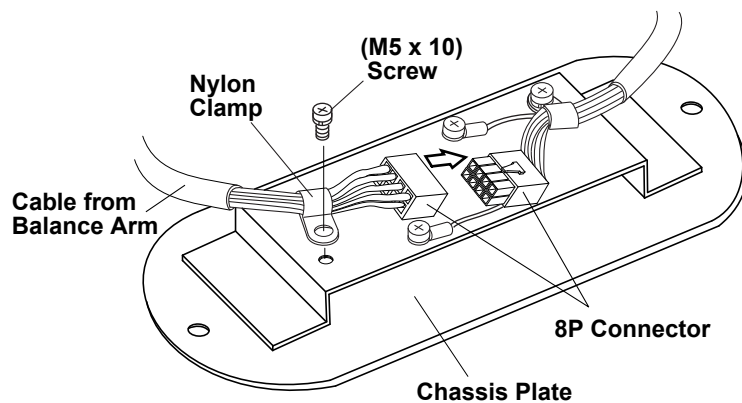

Fig.3-13 Balance Arm Installation

- Remove the arm end cap from horizontal arm.
Insert the stopper screw into upper threaded hole inside horizontal arm and tighten securely.
(Fig.3-14)

⚠ CAUTION

If stopper screw is not tightened securely, the Balance Arm can lift out of the horizontal arm.

- Insert the brake plug, brake spring and brake screw into the horizontal arm collar. (Fig.3-14)
Do not fully tighten.
- Set the arm end cap at the original place and fix it with end cap screw. Put the screw cover on it.
(Fig.3-14)

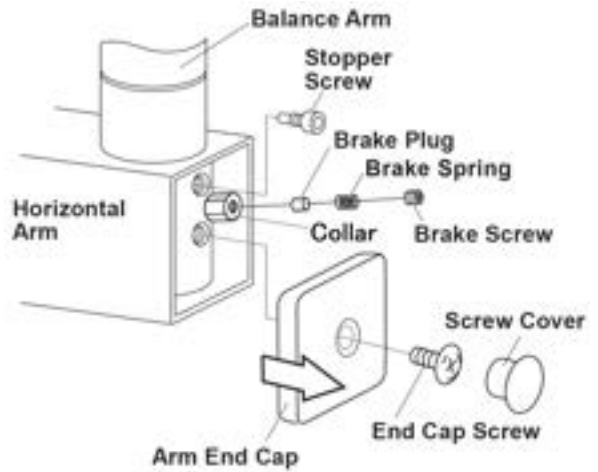

Fig.3-14 Attaching Balance Arm to Horizontal Arm

[4] HEAD ASSEMBLY INSTALLATION

⚠ WARNING

**Do not release Arm holding band until the X-ray head has been installed.
Balance arm assembly is spring loaded and can cause equipment damage and injury if not handled in the proper manner.
Refer to the Caution Tag on the band.**

- Remove the arm collar screw (M4 x 8mm) from the arm collar. Slide the arm collar upward and temporarily hold it in position with adhesive tape.
(Fig.3-15)
- Open the yoke inside cover of x-ray head by removing (M4 x15mm) cover screw.
(Fig.3-16)

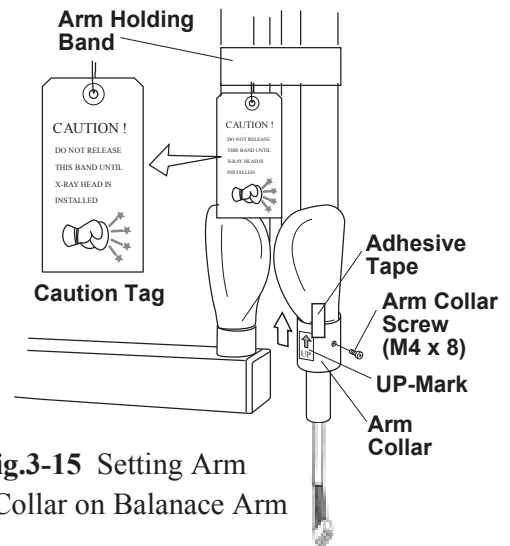

Fig.3-15 Setting Arm Collar on Balance Arm

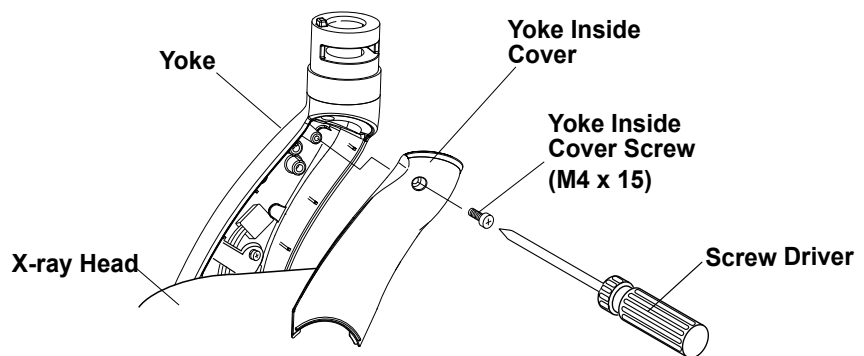

Fig.3-16 Removing Yoke Inside Cover

3. Making sure the stopper ring is placed on the yoke, insert the wiring from the balance arm assembly through the head shaft and into the yoke. (**Fig-3-16**)
4. Insert the shaft of the balance arm into the head yoke, and while holding the head in position, insert the head key securely into the retaining groove. (**Fig-3-16**)
5. Remove adhesive tape and slide the arm collar downward. Fix it in place with the arm collar screw. Remove the UP-mark from the arm collar. (**Fig-3-16**)

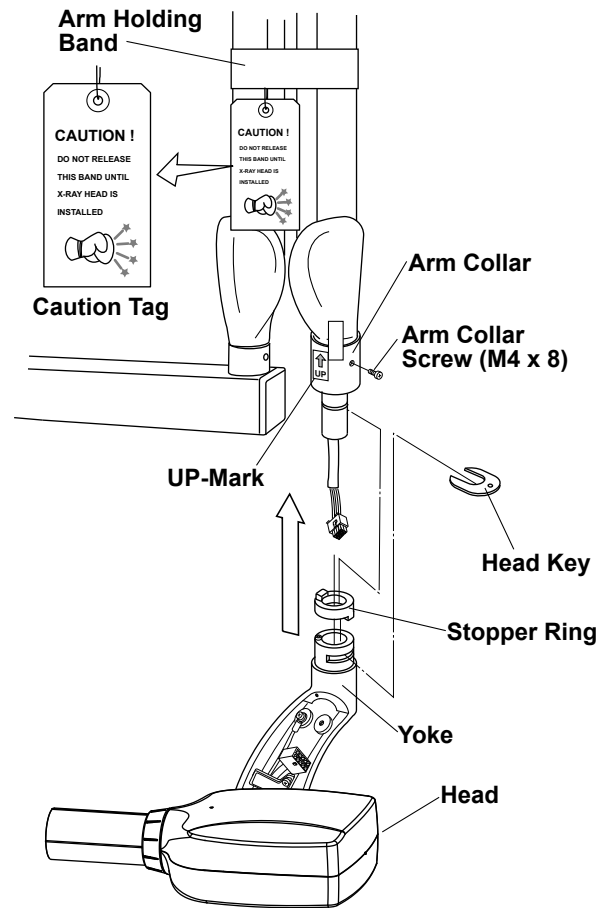

Fig.3-16 X-ray Head Installation

6. Loosen the (M5 × 10mm) screw and remove the nylon cable clamp from the yoke housing. Place cable clamp on the balance arm cable. Connect the **6P** connectors, and then attach the balance arm cable to the yoke housing with the nylon cable clamp. (**Fig-3-17**)
7. Reattach the yoke inside cover with the screw (M4 × 15mm). (**Fig-3-15**)
8. Remove arm holding band.

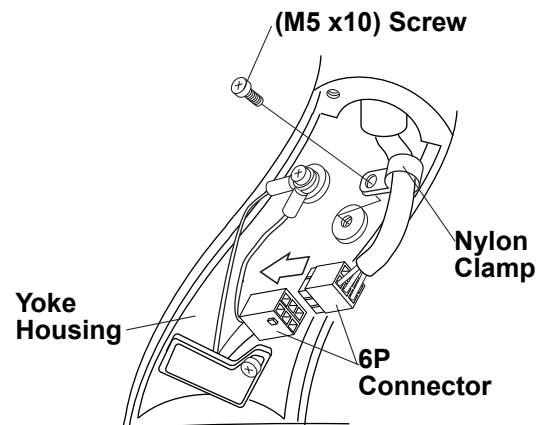

Fig.3-17 Connection 6P Connector in Yoke

[5] SUB CONTROLLER INSTALLATION

The wall and the strength of the hardware used must be checked and verified as being adequate to withstand a 10 pound (4.5kg) shear load. A flush mounted junction box with the necessary conduit and wiring should be pre-installed at 51-5/8" (1310mm) from the floor.

1. Remove two (M3 x8mm) screws from the under side of the controller and open the front panel. (**Fig.3-1**)

An optional hand exposure switch can be connected to the sub controller. Since this exposure switch has a coiled cord, operator can stand the most suitable position for operation.

The exposure switch on the front panel of sub controller and this hand exposure switch can be used. If local code prohibits use of both switches, disconnect the connector of either one of the switches.

Fig.3-

SECTION 4 : POST INSTALLATION INSPECTION

[1] ARM ASSEMBLY

1. Incorrect leveling of the wall plate and wall bracket can cause arm drift. First, check leveling with horizontal arm in position #1. (Fig.4-1) If not correct, bracket must be adjusted by placing shims between the arm bracket and wall plate. (Refer to page 9.)

IMPORTANT :

If the end of the horizontal arm shown in position #1 is pitched below level, then the tube head will drift away from the wall. If the end of the horizontal arm in position #1 is pitched above level, then the arm will require only minimum adjustment of the brake screw. (Fig.3-14)

2. Swing the horizontal arm to the far right end and far left end and check that the positive degrees at each location are equal. If those are not equal, adjust the arm mounting bracket as follows. (Fig.4-1)
 - a. Slightly loosen two top mounting bolts for arm mounting bracket.
 - b. Shift the bracket left or right until the positive degrees of the arm at each location become equal.
 - c. Move the horizontal arm to position # 1.
 - d. Fully tighten two top mounting bolts.
 - e. Fully tighten bottom mounting bolt.

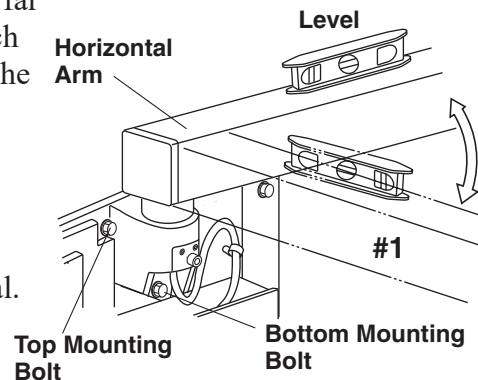

Fig.4-1 Horizontal Arm Adjustment

NOTE : Slight tendencies to drift can be corrected by tightening brake screw in horizontal arm. Do not tighten beyond what is required to prevent drift.

[2] BALANCE ARM TENSION ADJUSTMENT

1. Place the balance arm assembly into position.
2. If either balance arm drifts higher or lower from the set position, remove the spring adjuster cover and adjust the balance arm spring tension with the balance arm wrench supplied. (Fig.4-2)

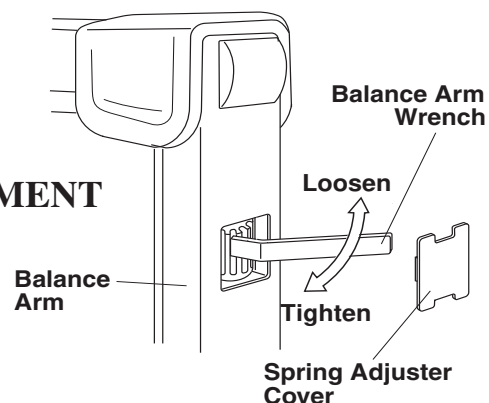

Fig.4-2 Balance Arm Tension Adjustment

[3] HEAD POSITIONING

- A. Place head into position.
- B. If head drifts from the set position, adjust the brake screws according to the following procedures. (Fig.4-3)
 1. Loosen the yoke side cap screw (ø3 x 8mm tapping screw) and remove the yoke side cap.
 2. Adjust the six brake screws using a screw driver.
 3. After adjustment, reattach the yoke side cap and screw.

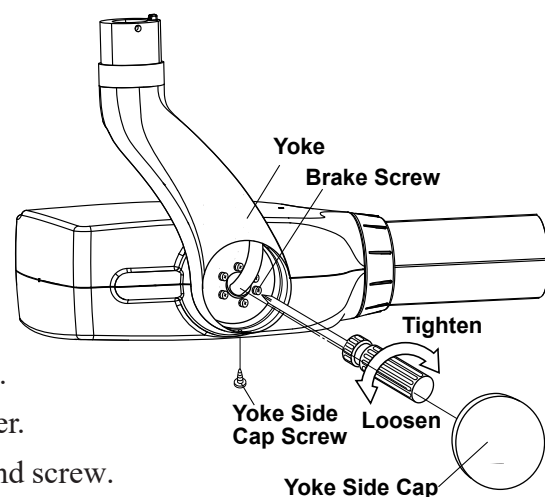

Fig.4-3 Head Positioning

SECTION 5 : CONTROL IDENTIFICATION AND OPERATION
[1] MAJOR COMPONENTS AND CONTROL IDENTIFICATION

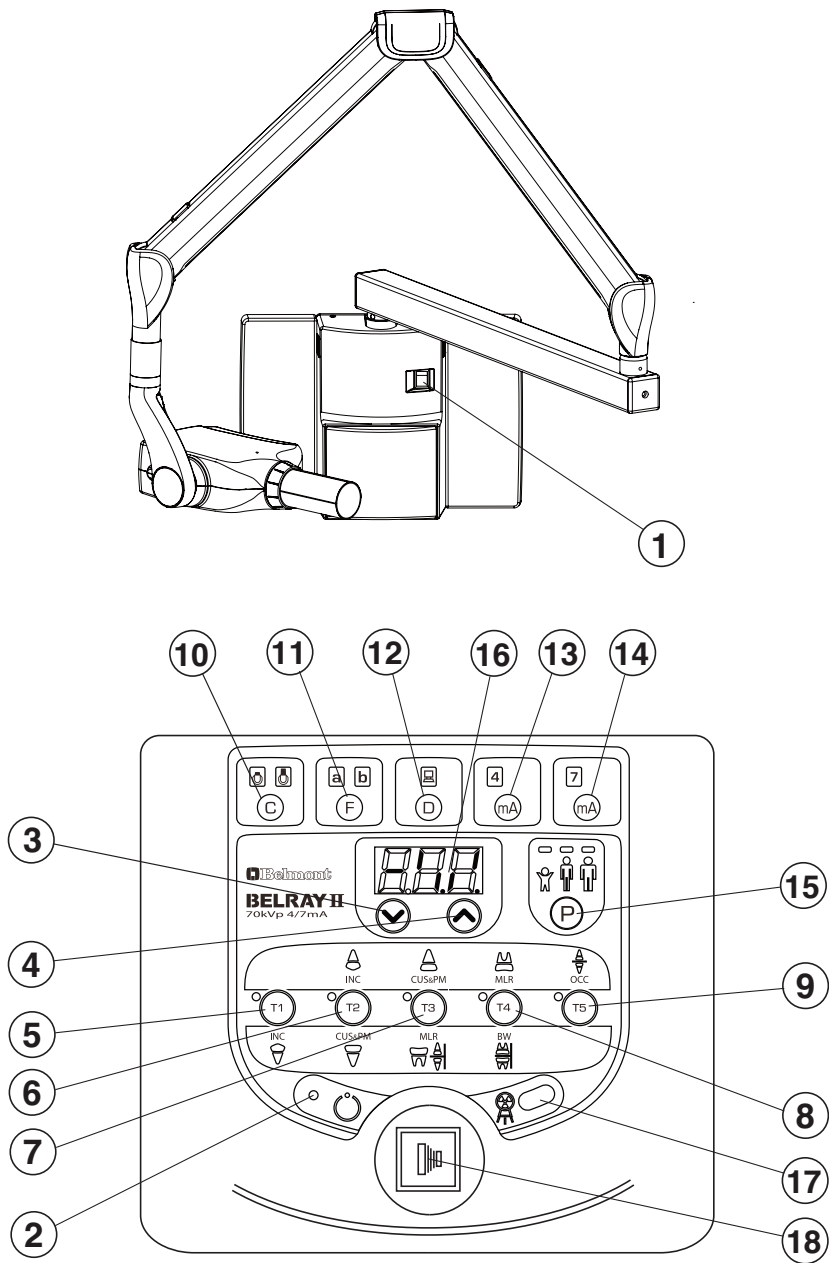

Fig.5-1 Major Components and Control Identification

- | | |
|--|---------------------------------|
| ① Main Power Switch | ⑩ Cone Type Selection Switch |
| ② Ready Light | ⑪ Film Speed Selection Switch |
| ③ ExposureTime Adjusting Switch (Down) | ⑫ Digital Imaging Switch |
| ④ ExposureTime Adjusting Switch (Up) | ⑬ 4 mA Selction Switch |
| ⑤ Tooth Selection Switch (T1) | ⑭ 7 mA Selection Switch |
| ⑥ Tooth Selection Switch (T2) | ⑮ Patient Size Selection Switch |
| ⑦ Tooth Selection Switch (T3) | ⑯ ExposureTime DisplayWindow |
| ⑧ Tooth Selection Switch (T4) | ⑰ ExposureWarning Light |
| ⑨ Tooth Selection Switch (T5) | ⑱ Exposure Switch |

[2] FUNCTION OF CONTROLS

① Main Power Switch

Pushing the upper side of this switch to the ON position energizes the x-ray unit. (Ready light and pre-select lights for cone type, film or digital, 4 mA, 7 mA, and patient size illuminate.) It is recommended to keep this switch OFF when the unit is not in use, in order to prevent an accidental exposure.

IMPORTANT : To prevent the risk of an accidental exposure, push the lower side of this switch to the OFF position, when the unit is not in use.

② Ready Light

This light illuminates when the line voltage is within operable range (108 ~ 132Vac). When this light is not on, exposure can not be made.

③④ Exposure Time Adjusting Switches

By momentarily pushing the ⤴ (or ⤵) switch, the exposure time displayed increases (or decreases) by one increment. By keeping the switch depressed more 2 sec., the exposure time displayed increases (or decreases) continuously until the switch is released.

Model 097 has the following 23 exposure time settings :

0.00, 0.02, 0.03, 0.04, 0.05, 0.06, 0.08, 0.10, 0.13, 0.16, 0.20, 0.25, 0.32, 0.40
0.50, 0.63, 0.80, 1.00, 1.25, 1.60, 2.00, 2.50, 3.20 (sec)

⑤ ~ ⑨ Tooth Selection Switches (T1 ~ T5)

Pushing one of these switches sets the exposure time automatically for the following ⑩ ~ ⑮ .

⑤ T1 : Incisor of Mandible

⑥ T2 : Incisor of Maxilla, Cuspid & Premolar of Mandible

⑦ T3 : Cuspid & Premolar of Maxilla, Molars of Mandible, Bitewing

⑧ T4 : Molar of Maxilla, Bitewing Molars

⑨ T5 : Occlusal

If the T1 switch⑤ is depressed more than 3 sec. unit goes into " Lock Mode". In lock mode, the only functional switch is the power switch. To exit from the lock mode, depress the T1 switch more than 3 sec. again.

⑩ Cone Type Selection Switch

Depressing this switch for more than 2 sec. selects the cone type : 8" standard cone or 12" optional long cone.

⑪ Film Speed Selection Switch

a. BELRAY II has 16 film speed settings. (F.00 ~ F.15)

Two speed settings are pre-set at the factory (a & b) and can be selected with switch ⑪.

a = Film speed No. F.09 (equivalent to ISO speed group " D", or Kodak Ultra-Speed film)

b = Film speed No. F.04 (equivalent to ISO speed group " F/E", or Kodak InSight film)

Including these two speeds, BELRAY II Model 097 x-ray can provide 16 different film speeds (F.00 ~ F.15) and any two of them can be programmed for easy selection. If doctor uses a different film speed, or prefers darker (or lighter) radiographs, the new speed can be programmed as page 26.

b. Pushing **Film Speed Selection Switch** ⑪ momentarily displays the selected film speed setting in the **Exposure Time Display Window** ⑮.

Depressing this switch for more then 2 sec. changes the film type between a and b.

c. If the **Digital Imaging Switch** ⑫ is depressed, both of the film speed indicating lights (a & b) are turned off.

⑫ **Digital Imaging Switch**

If a digital imaging system is used, shorter exposure time is often required. BELRAY II has 16 speeds for digital imaging (d.00 ~ d.15). Pushing this switch momentarily displays the speed being selected in the **Exposure Time Display Window** ⑩. With the factory speed setting d.08, the exposure time becomes half of F.08 setting. This setting should be adjusted according to the speed of the digital sensor or PSP (imaging plate) doctor uses as page 26.

⑬ **4 mA Selection Switch**

By momentarily depressing this switch, the tube current is set at 4 mA.

When Film switch is depressed, the tube current setting will be automatically changed to 7 mA.

⑭ **7 mA Selection Switch**

By momentarily depressing this switch, the tube current is set at 7 mA.

When digital switch is depressed, the tube current setting will be automatically changed to 4 mA.

⑮ **Patient Size Selection Switch**

This switch alters the selection of patient type/size to be radiographed (child →adult→large adult →child) and sets the exposure time automatically. If the weight of child is less than 20kg, press Ⓧ switch once after setting to child. If the weight of child is over 30kg and less than 50kg, press Ⓨ switch once after setting to child. If the weight of child is over 50kg and less than 70kg, press Ⓩ switch twice after setting to child. If the weight of child is over 70kg, set to adult.

NOTE: Setting or adjusting the exposure time manually (with Ⓨ or Ⓧ switch) supersedes

⑤ ~ ⑮ functions.

⑯ **Exposure Time Display Window**

This window displays the selected exposure time. Estimated air kerma (radiation output) at distal end of cone can be displayed in this window by manual operation or automatically after the exposure. If an abnormal condition exists or a malfunction occurs, an Error Code is also displayed in this window. (See Section :[6] **ERROR CODES**)

⑰ **Exposure Warning Light**

Illumination of this light indicates the unit is producing x-radiation.

⑱ **Exposure Switch**

This switch initiates radiographic exposure. When making an exposure, depress and hold this switch until the **Exposure Warning Light** ⑰ and the audible warning shut off. Failure to keep this switch depressed will result in the premature termination of the exposure and an error code E.00 will be displayed in **Exposure Time Display Window** ⑩.

[3] OPERATING PROCEDURES

1. Turn ON the Main Power Switch ①.
2. Confirm that Ready Light ② is illuminated.

NOTE : The ready light will not illuminate unless the incoming line voltage is correct and within the x-ray's operable range (108 ~ 132V AC).

3. Select the appropriate tooth type (⑤ ~ ⑨), and confirm the pre-selected conditions (cone type, film or digital, kV, mA and patient size) are suitable for exposure.

NOTE : To manually set the exposure time, depress either of the Manual Exposure Time Adjusting Switches (⤴ or ⤵) until the desired exposure time appears in the Exposure Time Display Window ⑩. While the unit is in manual mode, other selection switches (⑤ ~ ⑨) do not affect exposure time. (All of the tooth selection lights are off.) To return to the automatic exposure time selection mode, depress any one of Tooth Selection Switches (⑤ ~ ⑨).

4. Depress the Exposure Switch ⑱. When the Exposure Switch is depressed, the Exp. Warning Light ⑰ illuminates and the audible warning sounds. Do not release the Exposure Switch until the Exposure Warning Light and audible warning automatically shut off. Failure to keep the switch depressed will result in exposure being terminated prematurely.

5. To continue to radiograph other teeth, just select appropriate Tooth Selection Switches (⑤ ~ ⑨).

IMPORTANT : To protect x-ray tubehead from heat accumulation, wait for a time interval that is equal to 50 times the selected exposure time before making additional exposures. (Example : a 25 sec. wait is necessary between exposures that are 0.5 sec. in duration.)

6. Turn OFF the Main Power Switch ① in order to prevent accidental exposures when the unit is not in use.

NOTE : If the unit left over 8 min. without being operated and the Main Power Switch ① is kept on, figure "1" runs through the Exposure Time Display Window ⑩. This does not mean that malfunction of the unit has occurred ; this is an energy saving feature. The unit returns to ready condition by pressing any one of the switches, except the Exposure Switch ⑱.

[4] ESTIMATED AIR KERMA

Estimated air kerma (radiation output) at distal of cone can be displayed in the exposure time window by depressing the patient switch for more than 1 second. Unit for this value is mGy and this value is calculated by mA, Exposure time and Cone type selected at that time.

Patient type display lamps and displayed value in the window are flashing in this mode and if either of the manual exposure time adjusting switch is depressed during this mode, accumulated air kerma will be displayed. Accumulated value will be reset when the power switch is turned off or leave the x-ray unit more than 8 minutes without depressing any switch. To return to normal mode, press the patient switch for more than 1 second again.

[5] OPTIONAL HAND EXPOSURE SWITCH

An optional hand exposure switch can be connected to the sub controller. Since this exposure switch has a coiled cord, operators can stand in the most suitable position for operation. As controller has separate connector for this exposure switch, both exposure switch ⑱ on the front panel of sub controller and this hand exposure switch can be used.

If local code prohibits use of both, ask installer to disconnect the connector of either switch.

[6] ERROR CODES

If an abnormal condition exists in the unit, or a malfunction occurs, an error code is displayed in the Exposure Time Display Window (16). Please refer to the Table below.

Error Code	Condition	Step to be Taken	Possible Solution
E.00	Exposure switch was released before exposure termination.	All the tooth selection lights blink. Depress one of the tooth switches.	Release the exposure switch after the exposure light turns off.
E.01	Exposure switch was depressed within 10 sec. of previous exposure.	A 10 sec. delay is built in between each exposure. Release the exposure switch.	There should be a " wait" interval of 50 times the exposure time between successive exposures.
	Exposure time was set and exposure switch was depressed within 3 sec. of the power switch being turned on.		Wait a minimum 3 sec. after the main power switch is turned on before pressing the exposure switch.
E.02	Line voltage was less than 90% of rated voltage.		If line voltage is less than 90% of rated voltage, correct it by using a step-up transformer. (*)
E.03	Line voltage was more than 110% of rated voltage.		If line voltage is less than 110% of rated voltage, correct it by using a step-down transformer. (*)
E.04	Excess current during exposure.	Turn off the main power switch and wait for approximately 2 min. Turn on the main power switch again.	Contact customer service
E.05	Tube current at last portion of exposure was less than 3 mA at 4 mA setting or less than 5.25 mA at 7 mA setting.		Conduct the confirmation of tube current described in section 6.
E.06	Tube current at last portion of exposure was more than 5 mA at 4 mA setting or more than 8.75 mA at 7 mA setting.		
E.07	During the exposure, tube current becomes less than 2 mA at 4mA setting or less than 3.5 mA at 7 mA setting.		
E.08	During the exposure, tube current becomes more than 6 mA at 4mA setting or more than 10.5 mA at 7 mA setting.		
E.09	Malfunction of the microcomputer.		Contact customer service
E.10	Exposure switch or exposure circuit had been ON, when main power switch is turned on.	Release all the switches	Do not turn on the power while other switch is depressed.
E.11	Tube current is detected during pre-heating period.	Turn off the main power switch and wait for approximately 2 min. Turn on the main power switch again.	Contact customer service
E.12	Tube current is detected when main power switch is turned on.		

Error Code	Condition	Step to be Taken	Possible Solution
E.22	Failure of electrical communication between the power PCB and timer PCB.	Turn off the main power switch and wait for approximately 2 min. Turn on the main power switch again.	Contact customer service
E.23	Any switch on the sub controller is depressed when the main power switch is turned on. (Except the exposure switch)	Release all the switches	Do not turn on the power while other switch is depressed.

(*) Should a step up or down transformer be required to follow local and national electrical code for electrical ratings (120VAC, 60Hz, Single Phase, 0.8kVA) and installation.

[7] MAINTENANCE

BELRAY II MODEL 097 x-ray unit requires post installation confirmation and periodic maintenance checks to be performed by dealer service personnel. These procedures ensure that the x-ray unit is functioning within the manufacturer's specifications and remain in compliance with the Standard.

It is the responsibility of the owner of the unit to see that these maintenance checks are done **once a year** and that they are performed by a trained, certified service technician.

The specific instructions to perform these checks are located within this Installation Manual.

- A. Line voltage confirmation (page 24 ~25)
- B. Tube current confirmation (page 24)
- C. Inspection of arm and head movement (page 17)
- D. Mechanical safety
 1. The wall plate should be checked to confirm that it is securely attached to the wall.
 2. The arm mounting bracket should be checked to confirm that it is securely attached to the wall mounting plate. The arm mounting bracket must be level horizontally and vertically.
 3. Check and verify that the horizontal arm is not raising up and out of the arm mounting bracket. This should be verified routinely by treatment room personnel.

SECTION 6 : POST INSTALLATION CONFIRMATION

[1] CONFIRMATION OF POWER SUPPLY VOLTAGE

As specified in Electrical Requirements (page 5), power supply voltage must be within the operable range of 108 ~ 132 VAC. Confirm the power supply voltage again before turning on the unit.

1. Open the front panel of main controller by loosening two screws on top of the controller.
2. Remove the restriction plate from 3P terminal block.
3. Set the range of digital multimeter at 200 VAC, connect probes of multimeter to L and N of the 3P terminal block.

WARNING

Do not touch the restriction plate (refer to Fig.3-3) with the probes of multimeter during measurement, or a short circuit occurs.

4. Confirm that the reading is $120V \pm 10\%$ (108 ~ 132 VAC).

NOTE : BELRAY II MODEL 097 x-ray can not be operated unless the power supply voltage is within this range.

[2] CONFIRMATION OF TUBE CURRENT

BELRAY II Model 097 x-ray incorporates self diagnose and adjusting system to check if the tube current are within specified ranges at the beginning of exposure

1. Keep depressing tooth selection switches T1, T4 & T5 together until “h.○○” is appeared on the exposure time display window
2. Wait until the display changes to be "0.02", "0.10" or "0.50".
3. Make exposure by depressing the exposure switch.

WARNING

X-radiation is generated for 0.02, 0.1 or 0.5 second.

4. Repeat step 2. and 3. until “Fin” is displayed. This self diagnose and adjustment is automatically done for 4mA and 7mA.
5. If "Agn" is displayed, turn off the power switch and wait 3 seconds. Turn on the power switch again and repeat step 1. ~ 4. until "Fin" is displayed.

[3] CONFIRMATION OF EXPOSURE WARNING LIGHT & BUZZER

A. EXPOSURE WARNING BUZZER

1. Make an exposure and confirm that the exposure warning buzzer located within the sub controller is activated during the entire exposure.

B. EXPOSURE WARNING LIGHT

Exposure warning light is located on the front panel of the sub controller,

1. Make an exposure and confirm that the warning light illuminates during the exposure.

[4] CONFIRMATION OF LINE VOLTAGE REGULATION

1. Make sure that main power switch is "OFF".
2. Set the range of digital multimeter at 200 VAC, connect probes of multimeter to L and N of the 3P terminal block in the main controller.

⚠WARNING

Do not touch the restriction plate (refer to Fig.3-3) with the probes of multimeter during measurement, or a short circuit occurs.

3. Turn the main power switch on, and set the exposure time at 2.00 sec. with manual switch at 7mA.
4. Record the no-load line voltage (VN) indicated by the multimeter before exposure.
5. Make an exposure and record the load voltage (VL) indicated by the multimeter during exposure.

⚠WARNING

X-Radiation is generated for 2 seconds.

NOTE : Read the multimeter when the value is stabilized (about one second after exposure started).

6. Calculate line voltage regulation R(%) in the formula below :

$$R = \frac{VN - VL}{VL} \times 100 \quad \text{Record this value in "Assemblers Installation Report".}$$

NOTE : Line voltage regulation must not exceed the range of 0 ~ 3 %. If it is greater than 3%, the size of the power supply wires must be increased. Refer to the power supply requirements outlined on page 5 to determine the correct wire size necessary. If line voltage regulation is within the range, apparent resistance of supply line can be considered to be less than 0.5 OHM.

SECTION 7 : INITIAL SETTING

[1] SPEED SETTING FOR FILM AND DIGITAL IMAGING





A. FILM SPEED

Prior to shipment of the x-ray from the factory, the following two film speeds are programmed to be selected by the Film Speed Selection Switch.

a = Film speed F.09 (equivalent to ISO speed group "D", or Kodak Ultra-speed Film)

b = Film speed F.04 (equivalent to ISO speed group "F/E", or Kodak InSight Film)

In addition to these two speeds, BELRAY II MODEL 097 x-ray can provide 16 different film speeds (F.00 ~ F.15) and any two of them can be programmed for easy selection. If the doctor uses a different film speed, or prefers darker (or lighter) radiographs, the new speed can be programmed as follows. Higher speed settings make films darker. If film speed is increased by 1, exposure time becomes 25 % longer.

1. Keep the 4mA selection switch and 7mA selection switch depressed simultaneously for more than 3 seconds. Release the switches if the ready light starts to flash.
2. Push F switch momentarily until the "a" light above the F switch illuminates. The exposure time display window shows the present film speed for "a" setting. (The factory default setting, F.09 should be displayed.) By depressing  or  switch, increase or decrease film speed number until desired number for "a" setting is displayed.
3. To change the "b" setting from the factory default, F.05, push F switch momentarily until the "b" light illuminates. By depressing  or  switch, increase or decrease film speed until the desired number for "b" setting is displayed.
4. Press **T1 switch** to store these settings, then turn the main power switch off.

B. SPEED FOR DIGITAL IMAGING

BELRAY II MODEL 097 x-ray has 16 speeds for digital imaging (d.00 ~ d.15). The factory setting is d.08 and with this setting the exposure time becomes half of F.08 setting.

As the sensitivity is different according to each manufacturer of digital imaging sensors, this setting should be adjusted. To get a darker image, increase the speed setting and to get a lighter image, decrease the speed setting. If the speed setting is increased by 1, exposure time becomes 12 % longer.



1. Keep 4mA selection switch and 7mA selection switch depressed simultaneously for more than 3 seconds. Release the switches if the ready light starts to flash.
2. Push D switch momentarily until the light above the D switch illuminates and the exposure time display window shows the present speed setting. (The factory default setting d.08 should be displayed.)
3. By depressing  or  switch, increase or decrease speed until the desired number is displayed.
4. Press **T1 switch** to store these settings, then turn the main power switch off.

TABLE 1. Speed Setting and Exposure Time (7mA , Regular Cone)

[unit : sec.]

Patient Size	Child					Adult					Large Adult				
Tooth	T1	T2	T3	T4	T5	T1	T2	T3	T4	T5	T1	T2	T3	T4	T5
F. 00	0.02	0.04	0.04	0.06	0.08	0.04	0.06	0.08	0.10	0.13	0.04	0.08	0.08	0.13	0.16
F. 01	0.03	0.04	0.05	0.08	0.10	0.04	0.08	0.08	0.10	0.16	0.05	0.08	0.10	0.13	0.20
F. 02	0.03	0.05	0.06	0.08	0.13	0.05	0.08	0.10	0.13	0.20	0.06	0.10	0.13	0.16	0.25
F. 03	0.04	0.06	0.08	0.10	0.16	0.06	0.10	0.13	0.16	0.25	0.08	0.13	0.16	0.20	0.32
F. 04	0.05	0.08	0.10	0.13	0.16	0.08	0.13	0.16	0.20	0.32	0.10	0.16	0.20	0.25	0.32
F. 05	0.05	0.08	0.10	0.13	0.20	0.08	0.16	0.16	0.25	0.32	0.10	0.16	0.20	0.32	0.40
F. 06	0.06	0.10	0.13	0.16	0.25	0.10	0.16	0.20	0.25	0.40	0.13	0.20	0.25	0.32	0.50
F. 07	0.08	0.13	0.16	0.20	0.32	0.13	0.20	0.25	0.32	0.50	0.16	0.25	0.32	0.40	0.63
F. 08	0.10	0.16	0.20	0.25	0.40	0.16	0.25	0.32	0.40	0.63	0.20	0.32	0.40	0.50	0.80
F. 09	0.10	0.20	0.20	0.32	0.40	0.20	0.32	0.40	0.50	0.63	0.20	0.40	0.40	0.63	0.80
F. 10	0.13	0.20	0.25	0.32	0.50	0.20	0.40	0.40	0.63	0.80	0.25	0.40	0.50	0.63	1.00
F. 11	0.16	0.25	0.32	0.40	0.63	0.25	0.40	0.50	0.63	1.00	0.32	0.50	0.63	0.80	1.25
F. 12	0.20	0.32	0.40	0.50	0.80	0.32	0.50	0.63	0.80	1.25	0.40	0.63	0.80	1.00	1.60
F. 13	0.25	0.40	0.50	0.63	0.80	0.40	0.63	0.80	1.00	1.60	0.50	0.80	1.00	1.25	1.60
F. 14	0.25	0.50	0.50	0.80	1.00	0.40	0.80	0.80	1.25	1.60	0.50	1.00	1.00	1.60	2.00
F. 15	0.32	0.50	0.63	0.80	1.25	0.50	0.80	1.00	1.60	2.00	0.63	1.00	1.25	1.60	2.50
d. 00	*	0.02	0.02	0.03	0.04	0.02	0.03	0.04	0.05	0.06	0.02	0.04	0.04	0.06	0.08
d. 01	*	0.02	0.03	0.04	0.05	0.02	0.04	0.04	0.06	0.08	0.03	0.04	0.05	0.08	0.10
d. 02	*	0.03	0.03	0.04	0.06	0.03	0.04	0.05	0.06	0.10	0.03	0.05	0.06	0.08	0.13
d. 03	0.02	0.03	0.04	0.05	0.08	0.03	0.05	0.06	0.08	0.13	0.04	0.06	0.08	0.10	0.16
d. 04	0.02	0.04	0.05	0.06	0.08	0.04	0.06	0.08	0.10	0.13	0.05	0.08	0.10	0.13	0.16
d. 05	0.03	0.05	0.05	0.08	0.10	0.04	0.08	0.08	0.13	0.16	0.05	0.08	0.10	0.13	0.20
d. 06	0.03	0.05	0.06	0.08	0.13	0.05	0.08	0.10	0.13	0.20	0.06	0.10	0.13	0.16	0.25
d. 07	0.04	0.06	0.08	0.10	0.16	0.06	0.10	0.13	0.16	0.25	0.08	0.13	0.16	0.20	0.32
d. 08	0.05	0.08	0.10	0.13	0.20	0.08	0.13	0.16	0.20	0.32	0.10	0.16	0.20	0.25	0.40
d. 09	0.06	0.10	0.10	0.16	0.20	0.10	0.16	0.20	0.25	0.32	0.10	0.20	0.20	0.32	0.40
d. 10	0.06	0.10	0.13	0.16	0.25	0.10	0.20	0.20	0.32	0.40	0.13	0.20	0.25	0.32	0.50
d. 11	0.08	0.13	0.16	0.20	0.32	0.13	0.20	0.25	0.32	0.50	0.16	0.25	0.32	0.40	0.63
d. 12	0.10	0.16	0.20	0.25	0.40	0.16	0.25	0.32	0.40	0.63	0.20	0.32	0.40	0.50	0.80
d. 13	0.13	0.20	0.25	0.32	0.40	0.20	0.32	0.40	0.50	0.80	0.25	0.40	0.50	0.63	0.80
d. 14	0.13	0.25	0.25	0.40	0.50	0.20	0.40	0.40	0.63	0.80	0.25	0.50	0.50	0.80	1.00
d. 15	0.16	0.25	0.32	0.40	0.63	0.25	0.40	0.50	0.80	1.00	0.32	0.50	0.63	0.80	1.25

TABLE 2. Speed Setting and Exposure Time (4mA , Regular Cone)

[unit : sec.]

Patient Size	Child					Adult					Large Adult				
Tooth	T1	T2	T3	T4	T5	T1	T2	T3	T4	T5	T1	T2	T3	T4	T5
F. 00	0.04	0.06	0.08	0.10	0.16	0.06	0.10	0.13	0.16	0.25	0.08	0.13	0.16	0.20	0.32
F. 01	0.05	0.08	0.10	0.13	0.20	0.08	0.13	0.16	0.20	0.32	0.10	0.16	0.20	0.25	0.40
F. 02	0.06	0.10	0.10	0.16	0.20	0.10	0.16	0.20	0.25	0.32	0.10	0.20	0.20	0.32	0.40
F. 03	0.06	0.10	0.13	0.16	0.25	0.10	0.16	0.20	0.32	0.40	0.13	0.20	0.25	0.32	0.50
F. 04	0.08	0.13	0.16	0.20	0.32	0.13	0.20	0.25	0.32	0.50	0.16	0.25	0.32	0.40	0.63
F. 05	0.10	0.16	0.20	0.25	0.40	0.16	0.25	0.32	0.40	0.63	0.20	0.32	0.40	0.50	0.80
F. 06	0.10	0.20	0.25	0.32	0.40	0.20	0.32	0.40	0.50	0.80	0.25	0.40	0.50	0.63	0.80
F. 07	0.13	0.25	0.25	0.40	0.50	0.20	0.40	0.40	0.63	0.80	0.25	0.50	0.50	0.80	1.00
F. 08	0.16	0.25	0.32	0.40	0.63	0.25	0.40	0.50	0.63	1.00	0.32	0.50	0.63	0.80	1.25
F. 09	0.20	0.32	0.40	0.50	0.80	0.32	0.50	0.63	0.80	1.25	0.40	0.63	0.80	1.00	1.60
F. 10	0.25	0.40	0.50	0.63	1.00	0.40	0.63	0.80	1.00	1.60	0.50	0.80	1.00	1.25	2.00
F. 11	0.25	0.50	0.63	0.80	1.00	0.50	0.80	1.00	1.25	1.60	0.63	1.00	1.25	1.60	2.00
F. 12	0.32	0.50	0.63	1.00	1.25	0.50	1.00	1.00	1.60	2.00	0.63	1.25	1.25	2.00	2.50
F. 13	0.40	0.63	0.80	1.00	1.60	0.63	1.00	1.25	1.60	2.50	0.80	1.25	1.60	2.00	3.20
F. 14	0.50	0.80	1.00	1.25	2.00	0.80	1.25	1.60	2.00	3.20	1.00	1.60	2.00	2.50	*
F. 15	0.63	1.00	1.25	1.60	2.50	1.00	1.60	2.00	2.50	*	1.25	2.00	2.50	3.20	*
d. 00	0.02	0.03	0.04	0.05	0.08	0.03	0.05	0.06	0.08	0.13	0.04	0.06	0.08	0.10	0.16
d. 01	0.02	0.04	0.05	0.06	0.10	0.04	0.06	0.08	0.10	0.16	0.05	0.08	0.10	0.13	0.20
d. 02	0.03	0.05	0.06	0.08	0.10	0.05	0.08	0.10	0.13	0.16	0.06	0.10	0.10	0.16	0.20
d. 03	0.03	0.06	0.06	0.08	0.13	0.05	0.08	0.10	0.13	0.20	0.06	0.10	0.13	0.16	0.25
d. 04	0.04	0.06	0.08	0.10	0.16	0.06	0.10	0.13	0.16	0.25	0.08	0.13	0.16	0.20	0.32
d. 05	0.05	0.08	0.10	0.13	0.20	0.08	0.13	0.16	0.20	0.32	0.10	0.16	0.20	0.25	0.40
d. 06	0.06	0.10	0.10	0.16	0.20	0.10	0.16	0.20	0.25	0.40	0.10	0.20	0.25	0.32	0.40
d. 07	0.06	0.10	0.13	0.20	0.25	0.10	0.20	0.20	0.32	0.40	0.13	0.25	0.25	0.40	0.50
d. 08	0.08	0.13	0.16	0.20	0.32	0.13	0.20	0.25	0.32	0.50	0.16	0.25	0.32	0.40	0.63
d. 09	0.10	0.16	0.20	0.25	0.40	0.16	0.25	0.32	0.40	0.63	0.20	0.32	0.40	0.50	0.80
d. 10	0.13	0.20	0.25	0.32	0.50	0.20	0.32	0.40	0.50	0.80	0.25	0.40	0.50	0.63	1.00
d. 11	0.13	0.25	0.25	0.40	0.50	0.25	0.40	0.50	0.63	0.80	0.25	0.50	0.63	0.80	1.00
d. 12	0.16	0.25	0.32	0.50	0.63	0.25	0.50	0.50	0.80	1.00	0.32	0.50	0.63	1.00	1.25
d. 13	0.20	0.32	0.40	0.50	0.80	0.32	0.50	0.63	0.80	1.25	0.40	0.63	0.80	1.00	1.60
d. 14	0.25	0.40	0.50	0.63	1.00	0.40	0.63	0.80	1.00	1.60	0.50	0.80	1.00	1.25	2.00
d. 15	0.32	0.50	0.63	0.80	1.25	0.50	0.80	1.00	1.25	2.00	0.63	1.00	1.25	1.60	2.50

TABLE 3. Speed Setting and Exposure Time (7mA , Long Cone)

[unit : sec.]

Patient Size	Child					Adult					Large Adult				
Tooth	T1	T2	T3	T4	T5	T1	T2	T3	T4	T5	T1	T2	T3	T4	T5
F. 00	0.05	0.08	0.10	0.13	0.20	0.08	0.13	0.16	0.20	0.32	0.10	0.16	0.20	0.25	0.40
F. 01	0.06	0.10	0.10	0.16	0.20	0.10	0.16	0.20	0.25	0.32	0.10	0.20	0.20	0.32	0.40
F. 02	0.06	0.10	0.13	0.20	0.25	0.10	0.20	0.20	0.32	0.40	0.13	0.25	0.25	0.40	0.50
F. 03	0.08	0.13	0.16	0.20	0.32	0.13	0.20	0.25	0.32	0.50	0.16	0.25	0.32	0.40	0.63
F. 04	0.10	0.16	0.20	0.25	0.40	0.16	0.25	0.32	0.40	0.63	0.20	0.32	0.40	0.50	0.80
F. 05	0.10	0.20	0.25	0.32	0.40	0.20	0.32	0.40	0.50	0.80	0.25	0.40	0.50	0.63	0.80
F. 06	0.13	0.25	0.25	0.40	0.50	0.25	0.40	0.50	0.63	0.80	0.25	0.50	0.50	0.80	1.00
F. 07	0.16	0.25	0.32	0.40	0.63	0.25	0.50	0.50	0.80	1.00	0.32	0.50	0.63	0.80	1.25
F. 08	0.20	0.32	0.40	0.50	0.80	0.32	0.50	0.63	0.80	1.25	0.40	0.63	0.80	1.00	1.60
F. 09	0.25	0.40	0.50	0.63	1.00	0.40	0.63	0.80	1.00	1.60	0.50	0.80	1.00	1.25	2.00
F. 10	0.32	0.50	0.63	0.80	1.00	0.50	0.80	1.00	1.25	2.00	0.63	1.00	1.25	1.60	2.00
F. 11	0.32	0.63	0.63	1.00	1.25	0.50	1.00	1.00	1.60	2.00	0.63	1.25	1.25	2.00	2.50
F. 12	0.40	0.63	0.80	1.00	1.60	0.63	1.00	1.25	1.60	2.50	0.80	1.25	1.60	2.00	3.20
F. 13	0.50	0.80	1.00	1.25	2.00	0.80	1.25	1.60	2.00	3.20	1.00	1.60	2.00	2.50	3.20
F. 14	0.63	1.00	1.25	1.60	2.50	1.00	1.60	2.00	2.50	3.20	1.25	2.00	2.50	3.20	3.20
F. 15	0.63	1.25	1.25	2.00	2.50	1.25	2.00	2.50	3.20	3.20	1.25	2.50	2.50	3.20	3.20
d. 00	0.02	0.04	0.05	0.06	0.10	0.04	0.06	0.08	0.10	0.16	0.05	0.08	0.10	0.13	0.20
d. 01	0.03	0.05	0.06	0.08	0.10	0.05	0.08	0.10	0.13	0.16	0.06	0.10	0.10	0.16	0.20
d. 02	0.03	0.06	0.06	0.10	0.13	0.06	0.10	0.10	0.16	0.20	0.06	0.10	0.13	0.20	0.25
d. 03	0.04	0.06	0.08	0.10	0.16	0.06	0.10	0.13	0.16	0.25	0.08	0.13	0.16	0.20	0.32
d. 04	0.05	0.08	0.10	0.13	0.20	0.08	0.13	0.16	0.20	0.32	0.10	0.16	0.20	0.25	0.40
d. 05	0.06	0.10	0.10	0.16	0.20	0.10	0.16	0.20	0.25	0.40	0.10	0.20	0.25	0.32	0.40
d. 06	0.06	0.13	0.13	0.20	0.25	0.10	0.20	0.25	0.32	0.40	0.13	0.25	0.25	0.40	0.50
d. 07	0.08	0.13	0.16	0.20	0.32	0.13	0.25	0.25	0.40	0.50	0.16	0.25	0.32	0.40	0.63
d. 08	0.10	0.16	0.20	0.25	0.40	0.16	0.25	0.32	0.40	0.63	0.20	0.32	0.40	0.50	0.80
d. 09	0.13	0.20	0.25	0.32	0.50	0.20	0.32	0.40	0.50	0.80	0.25	0.40	0.50	0.63	1.00
d. 10	0.13	0.25	0.32	0.40	0.50	0.25	0.40	0.50	0.63	1.00	0.32	0.50	0.63	0.80	1.00
d. 11	0.16	0.25	0.32	0.50	0.63	0.25	0.50	0.50	0.80	1.00	0.32	0.63	0.63	1.00	1.25
d. 12	0.20	0.32	0.40	0.50	0.80	0.32	0.50	0.63	0.80	1.25	0.40	0.63	0.80	1.00	1.60
d. 13	0.25	0.40	0.50	0.63	1.00	0.40	0.63	0.80	1.00	1.60	0.50	0.80	1.00	1.25	2.00
d. 14	0.32	0.50	0.63	0.80	1.25	0.50	0.80	1.00	1.25	2.00	0.63	1.00	1.25	1.60	2.50
d. 15	0.32	0.63	0.63	1.00	1.25	0.63	1.00	1.25	1.60	2.00	0.63	1.25	1.25	2.00	2.50

TABLE 4. Speed Setting and Exposure Time (4mA , Long Cone)

[unit : sec.]

Patient Size	Child					Adult					Large Adult				
Tooth	T1	T2	T3	T4	T5	T1	T2	T3	T4	T5	T1	T2	T3	T4	T5
F. 00	0.08	0.13	0.16	0.20	0.32	0.13	0.20	0.25	0.32	0.50	0.16	0.25	0.32	0.40	0.63
F. 01	0.10	0.16	0.20	0.25	0.40	0.16	0.25	0.32	0.40	0.63	0.20	0.32	0.40	0.50	0.80
F. 02	0.13	0.20	0.25	0.32	0.50	0.20	0.32	0.40	0.50	0.80	0.25	0.40	0.50	0.63	1.00
F. 03	0.13	0.25	0.25	0.40	0.50	0.25	0.40	0.50	0.63	0.80	0.25	0.50	0.50	0.80	1.00
F. 04	0.16	0.25	0.32	0.50	0.63	0.25	0.50	0.50	0.80	1.00	0.32	0.50	0.63	1.00	1.25
F. 05	0.20	0.32	0.40	0.50	0.80	0.32	0.50	0.63	0.80	1.25	0.40	0.63	0.80	1.00	1.60
F. 06	0.25	0.40	0.50	0.63	1.00	0.40	0.63	0.80	1.00	1.60	0.50	0.80	1.00	1.25	2.00
F. 07	0.32	0.50	0.63	0.80	1.25	0.50	0.80	1.00	1.25	2.00	0.63	1.00	1.25	1.60	2.50
F. 08	0.32	0.63	0.63	1.00	1.25	0.63	1.00	1.25	1.60	2.00	0.63	1.25	1.25	2.00	2.50
F. 09	0.40	0.63	0.80	1.00	1.60	0.63	1.25	1.25	2.00	2.50	0.80	1.25	1.60	2.00	3.20
F. 10	0.50	0.80	1.00	1.25	2.00	0.80	1.25	1.60	2.00	3.20	1.00	1.60	2.00	2.50	*
F. 11	0.63	1.00	1.25	1.60	2.50	1.00	1.60	2.00	2.50	*	1.25	2.00	2.50	3.20	*
F. 12	0.80	1.25	1.60	2.00	2.50	1.25	2.00	2.50	3.20	*	1.60	2.50	3.20	*	*
F. 13	0.80	1.60	1.60	2.50	3.20	1.25	2.50	2.50	*	*	1.60	3.20	3.20	*	*
F. 14	1.00	1.60	2.00	2.50	*	1.60	2.50	3.20	*	*	2.00	3.20	*	*	*
F. 15	1.25	2.00	2.50	3.20	*	2.00	3.20	*	*	*	2.50	*	*	*	*
d. 00	0.04	0.06	0.08	0.10	0.16	0.06	0.10	0.13	0.16	0.25	0.08	0.13	0.16	0.20	0.32
d. 01	0.05	0.08	0.10	0.13	0.20	0.08	0.13	0.16	0.20	0.32	0.10	0.16	0.20	0.25	0.40
d. 02	0.06	0.10	0.13	0.16	0.25	0.10	0.16	0.20	0.25	0.40	0.13	0.20	0.25	0.32	0.50
d. 03	0.08	0.13	0.13	0.20	0.25	0.10	0.20	0.25	0.32	0.40	0.13	0.25	0.25	0.40	0.50
d. 04	0.08	0.13	0.16	0.25	0.32	0.13	0.25	0.25	0.40	0.50	0.16	0.25	0.32	0.50	0.63
d. 05	0.10	0.16	0.20	0.25	0.40	0.16	0.25	0.32	0.40	0.63	0.20	0.32	0.40	0.50	0.80
d. 06	0.13	0.20	0.25	0.32	0.50	0.20	0.32	0.40	0.50	0.80	0.25	0.40	0.50	0.63	1.00
d. 07	0.16	0.25	0.32	0.40	0.63	0.25	0.40	0.50	0.63	1.00	0.32	0.50	0.63	0.80	1.25
d. 08	0.16	0.32	0.32	0.50	0.63	0.32	0.50	0.63	0.80	1.00	0.32	0.63	0.63	1.00	1.25
d. 09	0.20	0.32	0.40	0.50	0.80	0.32	0.63	0.63	1.00	1.25	0.40	0.63	0.80	1.00	1.60
d. 10	0.25	0.40	0.50	0.63	1.00	0.40	0.63	0.80	1.00	1.60	0.50	0.80	1.00	1.25	2.00
d. 11	0.32	0.50	0.63	0.80	1.25	0.50	0.80	1.00	1.25	2.00	0.63	1.00	1.25	1.60	2.50
d. 12	0.40	0.63	0.80	1.00	1.25	0.63	1.00	1.25	1.60	2.50	0.80	1.25	1.60	2.00	2.50
d. 13	0.40	0.80	0.80	1.25	1.60	0.63	1.25	1.25	2.00	2.50	0.80	1.60	1.60	2.50	3.20
d. 14	0.50	0.80	1.00	1.25	2.00	0.80	1.25	1.60	2.00	3.20	1.00	1.60	2.00	2.50	*
d. 15	0.63	1.00	1.25	1.60	2.50	1.00	1.60	2.00	2.50	*	1.25	2.00	2.50	3.20	*

[2] PRIORITY OF SELECTIONS

Factory default setting :



Cone	: Regular cone
Film Speed	: off
Digital Imaging	: "d.08"
mA selection	: 7 mA
Patient Type	: Adult

If necessary, these settings can be changed. For example, if "D-speed" film is used for pedodontistry, "Film a" and "child" (patient type) should be selected.

1. Keep 4mA selection switch and 7mA selection switch depressed simultaneously for more than 3 seconds. Release the switches if the ready light starts to flash.
2. Press F switch momentarily. (Light for "Film a" illuminates and speed setting for "Film a" is displayed on exposure time display window.)
3. Select the patient type "child" by depressing P switch momentarily.
4. Press **T1 switch** to store these settings, then turn the main power switch off.
5. Cone type, mA selection can be changed by same procedures.

[3] ELECTRONIC CHIME ON/OFF



An electronic chime sounds when switches are depressed. If preferred, this sound can be deactivated as follows :

1. Keep T1 and T2 switches depressed together for more than 3 seconds.
Release the switches if the ready light starts to flash.
2. "bu. 2" will be displayed in exposure time display window.
3. By depressing either  or  switch, display changes to "bu.0".
4. Press **P switch** (Patient type Switch) until the buzzer beeps twice to store this setting and turn off the main power switch.

NOTE : Exposure Warning Buzzer and alarm sound of error code can not be eliminated.

[4] ESTIMATED AIR KERMA DISPLAY SETTING

With factory setting the estimated air kerma can be displayed only when the patient type selection switch is depressed more than 1 second. If automatic display after each exposure is preferred, change the display setting as follows.

1. Keep T2 and T5 switches depressed together for more than 3 seconds.
Release the switches if the ready light starts to flash.
2. "rd.1" will be displayed in exposure time display window.
3. By depressing either  or  switch, change display to "rd.2".
4. Press P switch (Patient type Switch) until the buzzer beeps twice to store this setting and turn off the main power switch.

NOTE : If "rd.0" is stored, estimated air kerma can not be displayed automatically or manually.

APPENDIX 1 : PARTS IDENTIFICATION

[1] ARM AND HEAD ASSEMBLY

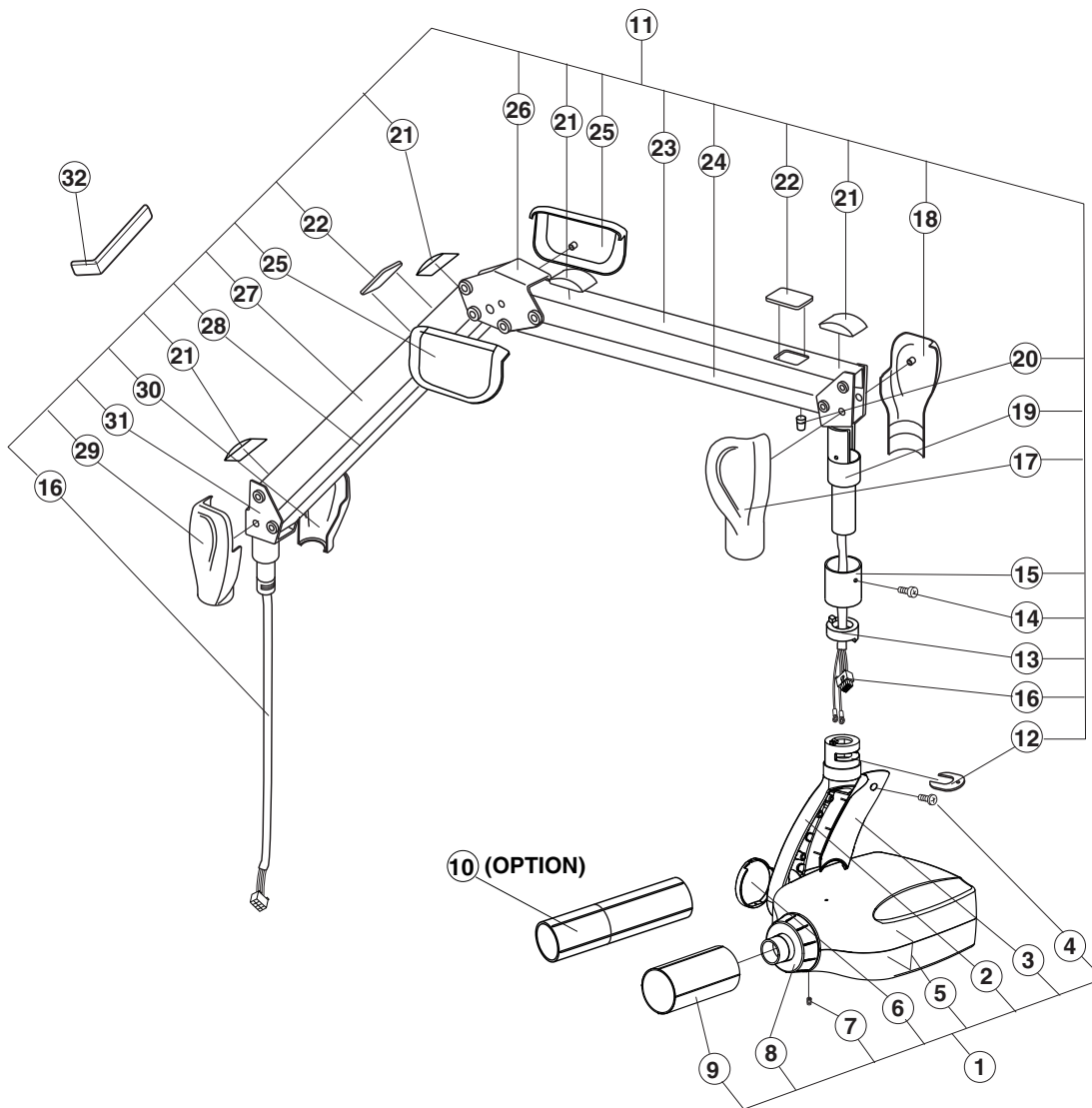

D.No.	Parts No.	Description	QTY
1	1P01CBA0	X-ray Head Assembly (USA)	1
	1P01CCA0	X-ray Head Assembly (Canada)	
2	ECPE24C0	Yoke	1
3	1A037UA0	Yoke Inside Cover	1
4	-----	Yoke Inside Cover Screw (M4 x 15)	1
5	-----	Head Housing Cover Set	1
6	1A04JJA0	Yoke Side Cap	1
7	-----	Yoke Side Cap Screw (ø3 x 8)	1
8	1A037RA0	Lock Nut for Cone	1
9	1P062XA0	Short Cone	1
10	1P01KJB0	Lone Cone (Option)	(1)
11	1P01CDA0	Balance Arm Assembly	1
12	ECQR62A0	Head Key	1
13	ECQR24A0	Stopper Ring	1
14	-----	Arm Collar Screw (M4 x 8)	1
15	ECQR31B0	Arm Collar	1
16	1A04DZB0	Wire Harness in Balance Arm	1

ID.No.	Parts No.	Description	QTY
17	ECPE18G0	Right Cover for Joint No.3	1
18	ECPE19G0	Left Cover for Joint No.3	1
19	ECPE16B0	Joint No.3	1
20	ECQR33A0	Cushion Absorber	1
21	ECQR27C0	Crevice Cover	2
22	ECQR30D0	Spring Adjuster Cover	2
23	ECPJ60B0	Arm Cover No.2	1
24	ECPE30B0	Balance Arm No.2	1
25	ECPJ64D0	Cover for Joint No.2	1
26	ECPJ58B0	Joint No.2	1
27	ECPJ59B0	Arm Cover No.1	1
28	ECPE31B0	Balance Arm No.1	1
29	ECPJ63G0	Left Cover for Joint No.1	1
30	ECPJ62G0	Right Cover or Joint No.1	1
31	ECPE15C0	Joint No.1	1
32	ECLJ82B0	Balance Arm Wrench	1

[2] CONTROLLER ASSEMBLY

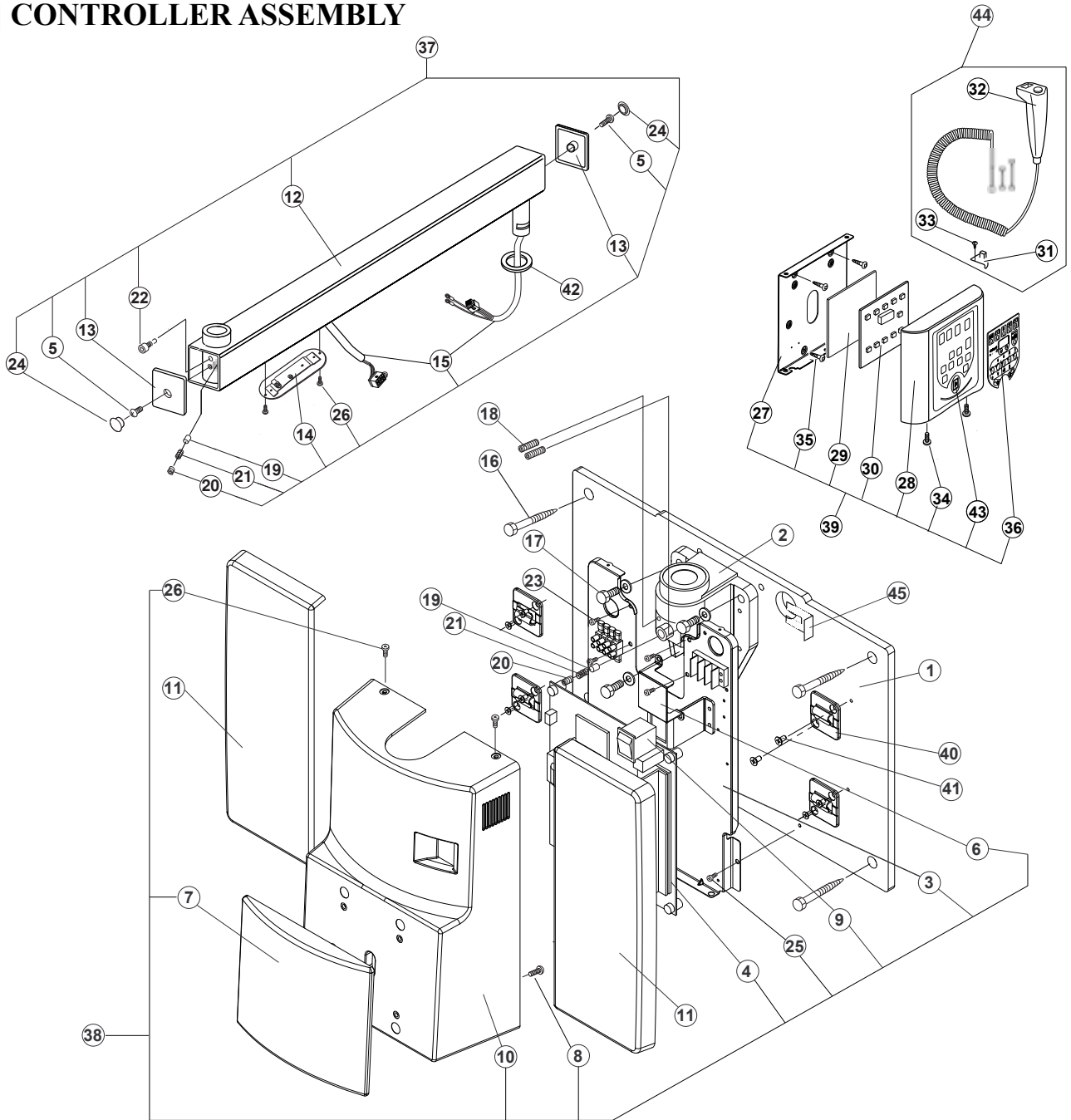

ID.No.	Parts No.	Description	QTY
1	1A04BYA0	Wall Plate	1
2	ECPE34B0	Arm Mounting Bracket	1
3	1A0389B0	Chassis	1
4	1A03Z6E0	Power PC Board	1
5	-----	End Cap Screw (M6 x 15)	2
6	1A0387A0	Restriction Plate	1
7	1A0386A0	Front Panel	1
8	-----	Screw for Front Panel (ø3 x 6)	1
9	1E01J8A0	Main Power Switch	1
10	1A0385C0	Front Cover	1
11	1A04JFA0	Side Cover	1
12	1A04BXC0	Horizontal Arm Frame (800mm)	1
13	ECLJ36A0	Arm End Cap	2
14	ECQR70C0	Arm Bottom Cover	2
15	1P01CXA0	Wire Harness in Horizontal Arm (800mm)	1
	1P01CYA0	Wire Harness in Horizontal Arm (1000mm)	
	1P01CZA0	Wire Harness in Horizontal Arm (300mm)	
	*1P01D0A0	Wire Harness in Horizontal Arm (500mm)	
	*1P01D1A0	Wire Harness in Horizontal Arm (650mm)	
16	-----	Lag Screw (ø9 x 75)	4
17	-----	Machine Bolt (M8 x 20)	3
18	ECPR44B0	Retaining Bolt (M6 x 35)	2
19	ECLS06C0	Brake Plug	2
20	-----	Brake Screw (M6 x 6)	2
21	ECLS11B0	Brake Spring	2
22	-----	Stopper Screw (M6)	1
23	-----	Screw for Chassis (M4 x 10)	4
24	ECNR24A0	Hole Plug for End Cap	2

ID.No.	Parts No.	Description	QTY
25	-----	Screw for Chassis (M4 x 6)	2
26	-----	Screw for Cover (M3 x 8)	2
27	1A0LYNC0	Chassis for Sub Controller	1
28	1A0NNEA0	Front Panel for Sub Controller	1
29	ECQR58A0	Protector for Timer PC Board	1
30	1A03L4C0	Timer PC Board	1
31	ECQR68B0	Hook for Hand Exposure Switch (Option)	(1)
32	1P059CA0	Hand Exposure Switch Assembly (Option)	(1)
33	-----	Tapping Screw (Option)	(1)
34	-----	Front Cover screw for Sub Controller (M3 x 8)	2
35	-----	Wood Screw (ø4.1 x 20)	4
36	1A03CKB0	Switch Sheet	1
	1P01CEB0	Horizontal Arm Assembly (800mm)	
	1P01CFB0	Horizontal Arm Assembly (1000mm)	
	1P01B7B0	Horizontal Arm Assembly (300mm)	
	*1P01CGB0	Horizontal Arm Assembly (500mm)	
37	*1P01CHB0	Horizontal Arm Assembly (650mm)	1
	1P01CJA0	Main Controller Assembly (USA)	
38	1P01CKA0	Main Controller Assembly (Canada)	1
	1P01CLA0	Sub Controller Assembly (USA)	
39	1P01CMA0	Sub Controller Assembly (Canada)	1
	1A04JGA0	Hook for Side Cover	
40	1A04JGA0	Hook for Side Cover	1
41	-----	Screw for Hook (M4 x 6)	1
42	EEMV52B0	Thrust Washer	1
43	EHLN17A0	Exposure Switch with Wires	1
44	1P05A3A0	Hand Exp. Switch Assembly with hook (Option)	(1)
45	1A0TCZA0	Shim	6

*Not available in USA.

APPENDIX 2 : CIRCUIT DIAGRAM

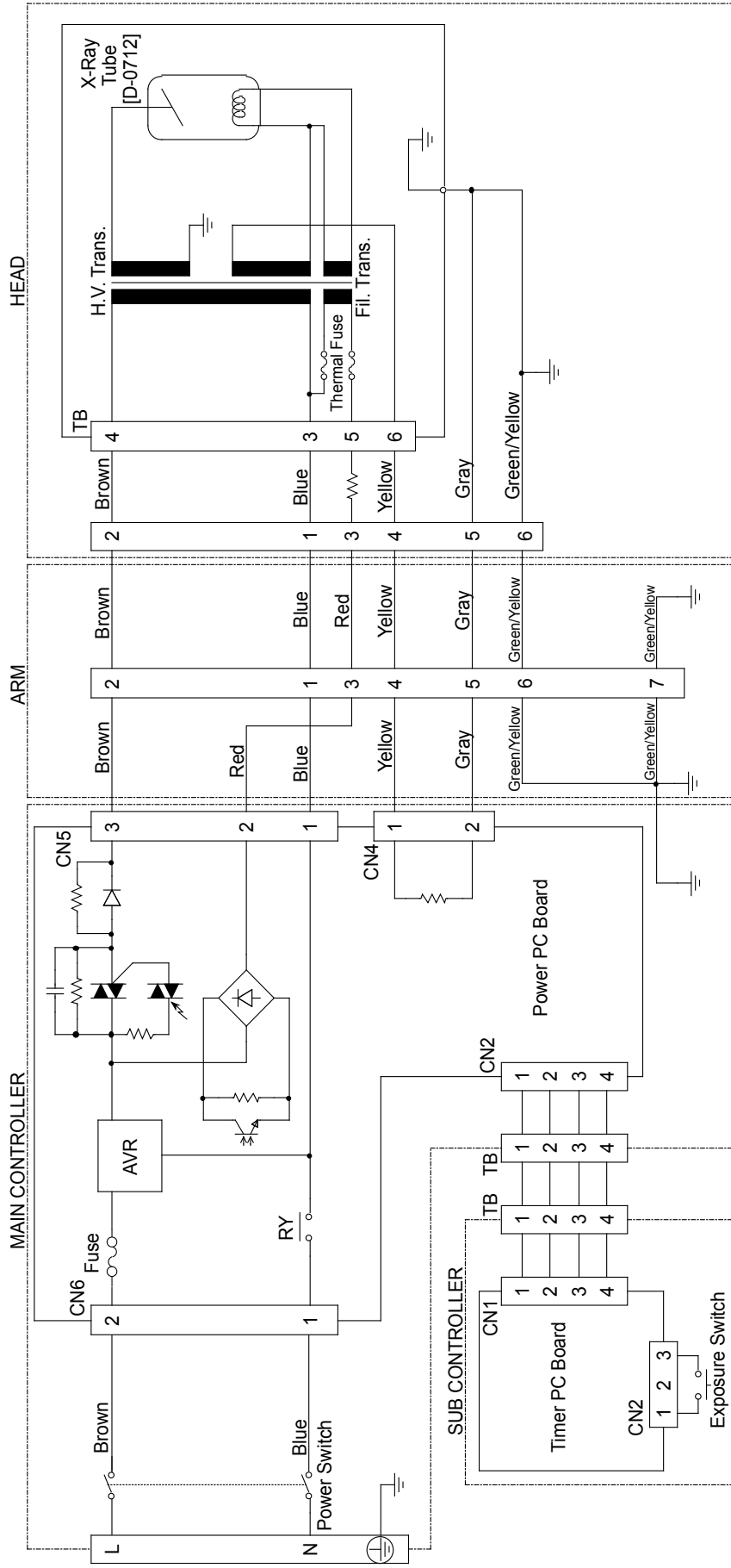

APPENDIX 3 : CERTIFICATION

FDA form 2579 must be filled and submitted to the purchaser and the relevant authorities within 15 days of completion of the installation. The fillable PDF copy of form 2579 is available online at <https://www.fda.gov/media/144454/download>.

Also fill the warranty card and the Assembler's installation report and return to Belmont Equipment.

REFER TO THE SAMPLE FORM :

FOR FDA USE ONLY	DEPARTMENT OF HEALTH AND HUMAN SERVICES PUBLIC HEALTH SERVICE FOOD AND DRUG ADMINISTRATION REPORT OF ASSEMBLY OF A DIAGNOSTIC X-RAY SYSTEM	From Approved: OMB No. 0910-0213 Expiration Date: December 31, 1992 See reverse for OMB statement. <div style="font-size: 2em; font-weight: bold; letter-spacing: 0.5em;">XXXXXXX</div>	
1. EQUIPMENT LOCATION			
a. NAME OF HOUSPITAL, DOCTOR OR OFFICE WHERE INSTALLED ✓		2. ASSEMBLER INFORMATION	
b. STREET ADDRESS ✓		a. COMPANY NAME ✓	
c. CITY ✓	d. STATE ✓	b. STREET ADDRESS ✓	
e. ZIP CORD ✓	f. TELEPHONE NUMBER ✓	c. CITY ✓	
		d. STATE ✓	
		e. ZIP CORD ✓	
		f. TELEPHONE NUMBER ✓	
3. GENERAL INFORMATION			
a. THIS REPORT IS FOR ASSEMBLY OF CERTIFIED COMPONETS WHICH ARE(Check appropriate box(es))			
<input checked="" type="checkbox"/> NEW ASSEMBLY - FULLY CHRTIFIED SYSTEM <input type="checkbox"/> REASSEMBLY - FULLY CHRTIFIED SYSTEM <input type="checkbox"/> REASSEMBLY - MIXED SYSTEM (Both certified and uncertified components)			
<input type="checkbox"/> REP;ACEMENT COMPONETS IN AN EXISTING SYSTEM <input type="checkbox"/> AN ADDITION TO AN EXISTING SYSTEM			
b. INTENDED USE(S)(Check applicable box(es))			
<input type="checkbox"/> GENERAL PURPOSE RADIOGRAPHY <input type="checkbox"/> GENERAL PURPOSE FLUOROSCOPY <input type="checkbox"/> TOMOGRAPHY (Other than CT) <input type="checkbox"/> ANGIOGRAPY			
<input type="checkbox"/> PODIATRY <input type="checkbox"/> UROLOGY <input type="checkbox"/> MAMMOGRAPHY <input type="checkbox"/> CHEST <input type="checkbox"/> CHIROPRACTIC			
<input type="checkbox"/> CT HEAD SCANNER <input type="checkbox"/> CT WHOLE BODY SCANNER <input checked="" type="checkbox"/> HEAD - NECK (Medical) <input checked="" type="checkbox"/> DENTAL - INTRAORAL <input type="checkbox"/> DENTAL - CEPHALOMETRIC			
<input type="checkbox"/> DENTAL PANRAMIC <input type="checkbox"/> RADIATION THERAPY SIMULATOR <input type="checkbox"/> C - ARM FLUOROSCOPIC <input type="checkbox"/> DIGITAL <input type="checkbox"/> OTHER (Specify in comments)			
c. THE X-RAY SYSTEM IS (Check one)		d. THE MASTER CONTROL IS IN ROOM	
<input checked="" type="checkbox"/> STATIONARY <input type="checkbox"/> MOBILE		Location of Control Box	
e. DATE OF ASSEMBLY			
<div style="display: flex; justify-content: space-around; align-items: center;"> <div style="text-align: center;">✓ (mo.)</div> <div style="text-align: center;">✓ (day)</div> <div style="text-align: center;">✓ (yr.)</div> </div>			
4. COMPONENT INFORMATION (If additional space is needed for this section use another form, replacing the preprinted number with form Number and complete items 1,4, and 5 only)			
a. THE MASTER CONTROL IS		b. CONTROL MANUFACTURER	
<input checked="" type="checkbox"/> A NEW INSTALLATION <input type="checkbox"/> EXISTING (Certified) <input type="checkbox"/> EXISTING (Non-certified)		Takara Belmont, USA Inc.	
		b. CONTROL SERIAL NUMBER ✓	
		c. SYSTEM MODEL NAME (CT Systems Only)	
		c. CONTROL MODEL NUMBER 097-CM, 097-CS	
Complete the following information for the certified components listed below which you installed. For beam limited device, tables and CT gantries the manufacturer and Model number in the indicated spaces. For other certified components, enter in the appropriat block how many of each you installed in this system.			
f. SELECTED COMPONENTS			
BEAM LIMITING DEVICE	MANUFACTURER	MODEL NUMBER	DATE MANUFACTURED
	MANUFACTURER	MODEL NUMBER	DATE MANUFACTURED
TABLES	MANUFACTURER	MODEL NUMBER	DATE MANUFACTURED
	MANUFACTURER	MODEL NUMBER	DATE MANUFACTURED
CT GANTRY	MANUFACTURER	MODEL NUMBER	DATE MANUFACTURED
f. OTHER CERTIFIED COMPONENTS			
(Enter number of each installed in appropriate blocks)			
<input checked="" type="checkbox"/> 1 X-RAY CONTROL <input type="checkbox"/> HIGH VOLTAGE GENERATOR <input type="checkbox"/> VERTICAL CASSETTE HOLDER <input type="checkbox"/> TUBE HOUSING ASSEMBLY (Medical) <input checked="" type="checkbox"/> 1 DENTAL TUBE HEAD		<input type="checkbox"/> CRADLE <input type="checkbox"/> FILM CHANGER <input type="checkbox"/> IMAGE INTENSIFIER <input type="checkbox"/> SPOT FILM DEVICE <input type="checkbox"/> OTHER (Specify)	
5. ASSEMBLER CERTIFICATION			
I affirm that all certified components assembled or installed by me for which this report is being made, were adjusted and tested by me according to the instructions provided by the manufacturer(s), were of the type required by the diagnostic x-ray performance standard (21 CFR Part 1020), were not modified to adversely affect performance, and were insralled in accordance with provisions of 21 CFR Part 1020. I also affirm that all instruction manuals and other infomation required by 21 CFR Part 1020 for this assembly have been furnished to the purchaser and within 15 days from the date of assembly, each copy of this report will be distributed as indicated at the bottom of each copy.			
a. PRINTED NAME ✓		b. SIGNATURE ✓	
		c. DATE ✓	
d. COMMENTS			

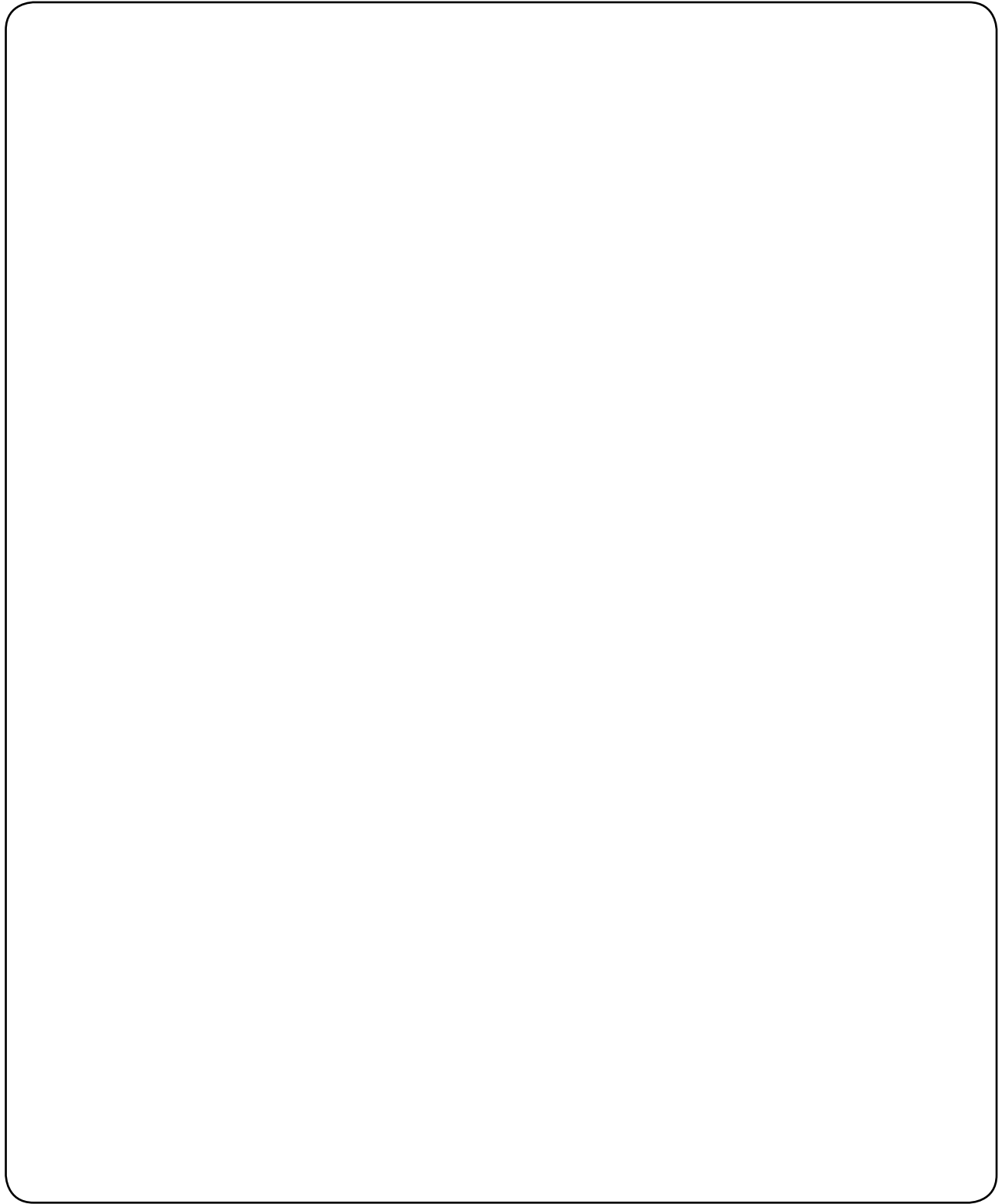

BELMONT EQUIPMENT, Division of Takara Belmont, USA, Inc.
101 Belmont Drive Somerset, New Jersey 08873 U.S.A. TEL.:(732) 469-5000 / (800) 223-1192 Fax.:(732) 526-6322 / (800) 280-7504
www.belmontequip.com

TAKARA COMPANY, CANADA, LTD.
2455 Meadowvale Boulevard, Mississauga, Ontario, L5N 5S2, Canada TEL.:(905) 816-8965 Fax.:(905) 816-8999
www.belmont.ca