

# **BELRAY II**

**MODEL 097**

***DENTAL X-RAY***

**OPERATOR'S  
INSTRUCTIONS  
(for USA & Canada)**

**⚠ WARNING**

**This X-ray unit may be dangerous to patient and operator unless safe exposure factors, operating instructions and maintenance schedules are observed.**

** Belmont<sup>®</sup>**

## INDEX

	PAGE
[ 1 ] INTRODUCTION -----	1
[ 2 ] LAYOUT OF CONTROLS -----	3
[ 3 ] FUNCTION OF CONTROLS -----	4
[ 4 ] OPERATING PROCEDURES -----	7
[ 5 ] ESTIMATED AIR KERMA -----	7
[ 6 ] OPTIONAL HAND EXPOSURE SWITCH -----	7
[ 7 ] DIGITAL IMAGING SYSTEM -----	8
[ 8 ] DISINFECTION AND CLEANING -----	8
[ 9 ] ERROR CODES -----	9
[ 10 ] MAINTENANCE -----	10
[ 11 ] DISPOSAL -----	10
[ 12 ] TECHNICAL DATA -----	11
[ 13 ] ELECTROMAGNETIC COMPATIBILITY (EMC) -----	12

## [ 1 ] INTRODUCTION

### 1. GENERAL

This manual provides information for the operation and maintenance procedures and technical specifications for the BELRAY II MODEL 097 dental x-ray. The instructions contained in this book should be thoroughly read and understood before operation.

**The BELRAY II MODEL 097 has no user serviceable items. Maintenance and repair should be performed by qualified dealer service personnel.**

### 2. Intended Use of the Product

The BELRAY II MODEL 097 is an extraoral source dental radiographic x-ray unit. This unit works as a diagnostic purpose x-ray source for human teeth with the resultant image recorded on intra-oral dental x-ray film or image receptor.

### 3. PARTS IDENTIFICATION OF X-RAY SYSTEM "BELRAY II" MODEL 097

- a. Tube housing assembly : 097-H
- b. X-ray controls : 097-CM (main controller), 097-CS (sub controller)
- c. Cones : 097-R (regular), 097-L (long)
- d. Balance arm : 097-A

### 4. COMPLIANCE WITH STANDARD

The BELMONT BELRAY II MODEL 097 x-ray unit complies with the following standard.























- a. Electrical and Mechanical Safety
  - IEC60601-1 : 1988
  - UL60601-1 : 2003
- b. Radiation Safety
  - 21 CFR 1020.30

### 5. CLASSIFICATION

- 5-1. According to Section 513 of Federal Food, Drug and Cosmetic Act and 21 CFR Part 806, the BELMONT BELRAY II MODEL 097 is classified as CLASS II Medical Device.
- 5-2. According to IEC60601-1, the BELMONT BELRAY II MODEL 097 is classified as follows.
  - a. Protection against electric shock : Class I Equipment, Type B Applied Parts
  - b. Protection against ingress of water : Ordinary
  - c. Mode of operation : Continuous Operation with Intermittent Loading  
(Duty Cycle = 1 : 50)
  - d. Equipment not suitable for use in the presence of a flammable anesthetic mixture with air or with oxygen or nitrous oxide.

## 6. SYMBOL

In this book, on the labels or on the control panel of the BELRAY II MODEL 097, following symbols are used. Confirm the meaning of each symbol.

	Consult written Instructions in Manuals		Protection against electric shock : Type B		ON (POWER)		OFF (POWER)
	Protection Grounding		Exposure Switch		X-ray Emission		Ready
	Upper Incisor		Upper Cuspid & Pre Molar		Upper Molar		Occlusal
	Lower Incisor		Lower Cuspid & Pre Molar		Lower Molar & Bite Wing		Bite Wing
	Digital Imaging		Patient Child		Patient Adult		Patient Large Adult
	Regular Cone		Long Cone		Non-ionizing Radiation		Date of Manufacture

## 7. SAFETY

This X-ray unit may be dangerous to patient and operator unless safe exposure factors, operating instructions and maintenance schedules are observed.

Only qualified and authorized personnel may operate this equipment observing all laws and regulations concerning protection against x-ray radiation.

The operator must :

- have means for audio and visual communication with the patient.
- have full view of kV, mA, timer selections and exposure warning light.
- be at least 2 m away from the x-ray head and patient and out of the path of the x-ray beam or be positioned behind a protective device.
- fully use all radiation protection devices, accessories and procedures available to protect the patient and operator from x-ray radiation.

### **WARNING**

**California proposition 65**

Cancer and Reproductive Harm - [www.P65Warnings.ca.gov](http://www.P65Warnings.ca.gov).

## [ 2 ] LAYOUT OF CONTROLS

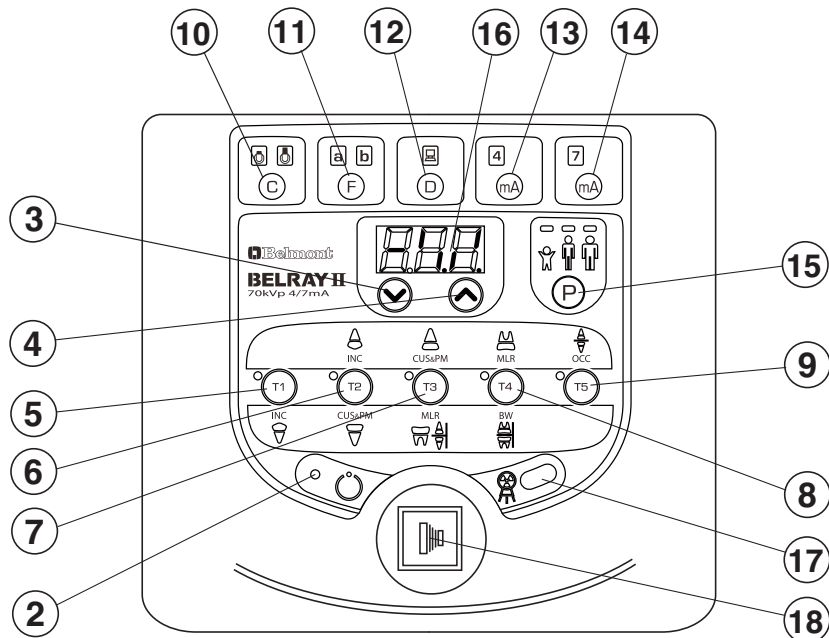
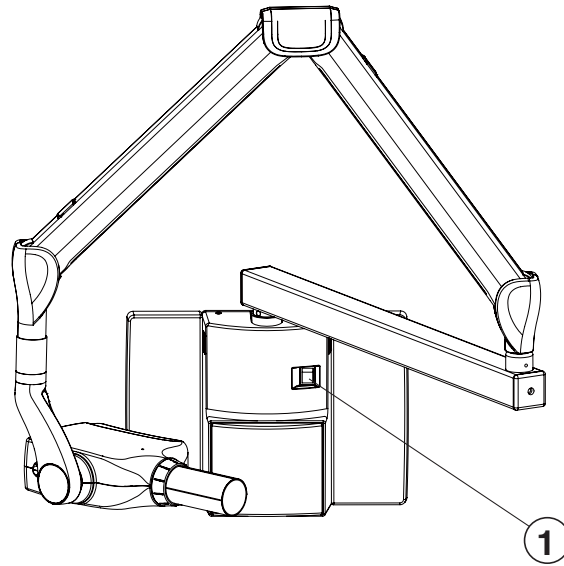

- |  |                                 |
|--|---------------------------------|
| ① Main Power Switch                    | ⑩ Cone Type Selection Switch    |
| ② Ready Light                          | ⑪ Film Speed Selection Switch   |
| ③ ExposureTime Adjusting Switch (Down) | ⑫ Digital Imaging Switch        |
| ④ ExposureTime Adjusting Switch (Up)   | ⑬ 4 mA Selson Switch            |
| ⑤ Tooth Selection Switch (T1)          | ⑭ 7 mA Selection Switch         |
| ⑥ Tooth Selection Switch (T2)          | ⑮ Patient Size Selection Switch |
| ⑦ Tooth Selection Switch (T3)          | ⑯ ExposureTime Display Window   |
| ⑧ Tooth Selection Switch (T4)          | ⑰ ExposureWarning Light         |
| ⑨ Tooth Selection Switch (T5)          | ⑱ Exposure Switch               |

### [ 3 ] FUNCTION OF CONTROLS

#### ① Main Power Switch

Pushing the upper side of this switch to the ON position energizes the x-ray unit. (Ready light and pre-select lights for cone type, film or digital, 4 mA, 7 mA, and patient size illuminate.) It is recommended to keep this switch OFF when the unit is not in use, in order to prevent an accidental exposure.

**IMPORTANT : To prevent the risk of an accidental exposure, push the lower side of this switch to the OFF position, when the unit is not in use.**

#### ② Ready Light

This light illuminates when the line voltage is within operable range (108 ~ 132Vac). When this light is not on, exposure can not be made.

#### ③④ Exposure Time Adjusting Switches

By momentarily pushing the  $\text{⤴}$  (or  $\text{⤵}$ ) switch, the exposure time displayed increases (or decreases) by one increment. By keeping the switch depressed more 2 sec., the exposure time displayed increases (or decreases) continuously until the switch is released.

Model 097 has the following 23 exposure time settings :

0.00, 0.02, 0.03, 0.04, 0.05, 0.06, 0.08, 0.10, 0.13, 0.16, 0.20, 0.25, 0.32, 0.40  
0.50, 0.63, 0.80, 1.00, 1.25, 1.60, 2.00, 2.50, 3.20 (sec)

#### ⑤ ~ ⑨ Tooth Selection Switches (T1 ~ T5)

Pushing one of these switches sets the exposure time automatically for the following ⑩ ~ ⑮ .

⑤ T1 : Incisor of Mandible

⑥ T2 : Incisor of Maxilla, Cuspid & Premolar of Mandible

⑦ T3 : Cuspid & Premolar of Maxilla, Molars of Mandible, Bitewing

⑧ T4 : Molar of Maxilla, Bitewing Molars

⑨ T5 : Occlusal

If the T1 switch⑤ is depressed more than 3 sec. unit goes into " Lock Mode". In lock mode, the only functional switch is the power switch. To exit from the lock mode, depress the T1 switch more than 3 sec. again.

#### ⑩ Cone Type Selection Switch

Depressing this switch for more than 2 sec. selects the cone type : 8" standard cone or 12" optional long cone.

#### ⑪ Film Speed Selection Switch

a. The BELRAY II has 16 film speed settings. (F.00 ~ F.15)

Two speed settings are pre-set at the factory (a & b) and can be selected with switch ⑪.

a = Film speed No. F.09 (equivalent to ISO speed group " D", or Kodak Ultra-Speed film)

b = Film speed No. F.04 (equivalent to ISO speed group " F/E", or Kodak InSight film)

Including these two speeds, the BELRAY II Model 097 x-ray can provide 16 different film speeds (F.00 ~ F.15) and any two of them can be programmed for easy selection. If doctor uses a different film speed, or prefers darker (or lighter) radiographs, the new speed can be programmed as follows. Higher speed settings make films darker. If film speed is increased by 1, exposure time becomes 25 % longer.

1. Keep the 4 mA selection switch and 7 mA selection switch depressed simultaneously for more than 3 seconds. Release the switches if the ready light starts to flash.

2. Push F switch momentarily until the "a" light above the F switch illuminates. The exposure time display window shows the present film speed for "a" setting. (The factory default setting, F.09 should be displayed.) By depressing  $\triangleup$  or  $\triangledown$  switch, increase or decrease film speed number until desired number for "a" setting is displayed.
  3. To change the "b" setting from the factory default, F.04, push F switch momentarily until the "b" light illuminates. By depressing  $\triangleup$  or  $\triangledown$  switch, increase or decrease film speed until the desired number for "b" setting is displayed.
  4. Press T1 switch to store these settings, then turn the main power switch off.
- b. Pushing **Film Speed Selection Switch** ⑪ momentarily displays the selected film speed setting in the **Exposure Time Display Window** ⑩  
Depressing this switch for more than 2 sec. changes the film type being selected.
- c. If the **Digital Imaging Switch** ⑫ is depressed, both of the film speed indicating lights (a & b) are turned off.

### ⑫ Digital Imaging Switch

If a digital imaging system is used, shorter exposure time is often required. The BELRAY II has 16 speeds for digital imaging (d.00 ~ d.15). Pushing this switch momentarily displays the speed being selected in the **Exposure Time Display Window** ⑩. With the factory speed setting d.08, the exposure time becomes half of F.08 setting.

As the sensitivity is different according to each manufacturer of digital imaging sensors, this setting should be adjusted. To get a darker image, increase the speed setting and to get a lighter image, decrease the speed setting. If the speed setting is increased by 1, exposure time becomes 12 % longer.

1. Keep 4 mA selection switch and 7 mA selection switch depressed simultaneously for more than 3 seconds.
2. Push D switch momentarily until the light above the D switch illuminates and the exposure time display window shows the present speed setting. (The factory default setting d.08 should be displayed.)
3. By depressing  $\triangleup$  or  $\triangledown$  switch, increase or decrease speed until the desired number is displayed.
4. Press **T1 switch** to store these settings, then turn the main power switch off.

### ⑬ 4 mA Selection Switch

By momentarily depressing this switch, the tube current is set at 4 mA.

When Film switch is depressed, the tube current setting will be automatically changed to 7 mA.

### ⑭ 7 mA Selection Switch

By momentarily depressing this switch, the tube current is set at 7 mA.

When digital switch is depressed, the tube current setting will be automatically changed to 4 mA.

#### 15 Patient Size Selection Switch

This switch alters the selection of patient type/size to be radiographed (child adult large adult child) and sets the exposure time automatically. If the weight of child is less than 20kg, press switch once after setting to child. If the weight of child is over 50kg and less than 70kg, press switch twice after setting to child. If the weight of child is over 70kg, set to adult.

**NOTE: Setting or adjusting the exposure time manually (with or switch) supersedes**

## [ 4 ] OPERATING PROCEDURES

1. Turn ON the Main Power Switch ①.
2. Confirm that Ready Light ② is illuminated.

**NOTE : The ready light will not illuminate unless the incoming line voltage is correct and within the x-ray's operable range (108 ~ 132V AC).**

3. Select the appropriate tooth type (⑤ ~ ⑨), and confirm the pre-selected conditions (cone type, film or digital, kV, mA and patient size) are suitable for exposure.

**NOTE : To manually set the exposure time, depress either of the Manual Exposure Time Adjusting Switches (⤴ or ⤵) until the desired exposure time appears in the Exposure Time Display Window ⑯. While the unit is in manual mode, other selection switches (⑤ ~ ⑯) do not affect exposure time. (All of the tooth selection lights are off.) To return to the automatic exposure time selection mode, depress any one of Tooth Selection Switches (⑤ ~ ⑨).**

4. Depress the Exposure Switch ⑱. When the Exposure Switch is depressed, the Exp. Warning Light ⑰ illuminates and the audible warning sounds. Do not release the Exposure Switch until the Exposure Warning Light and audible warning automatically shut off. Failure to keep the switch depressed will result in exposure being terminated prematurely.
5. To continue to radiograph other teeth, just select appropriate Tooth Selection Switches (⑤ ~ ⑨).

**IMPORTANT : To protect x-ray tubehead from heat accumulation, wait for a time interval that is equal to 50 times the selected exposure time before making additional exposures. (Example : a 25 sec. wait is necessary between exposures that are 0.5 sec. in duration.)**

6. Turn OFF the Main Power Switch ① in order to prevent accidental exposures when the unit is not in use.

**NOTE : If the unit left over 8 min. without being operated and the Main Power Switch ① is kept on, figure "1" runs through the Exposure Time Display Window ⑯. This does not mean that malfunction of the unit has occurred ; this is an energy saving feature. The unit returns to ready condition by pressing any one of the switches, except the Exposure Switch ⑱.**

## [ 5 ] ESTIMATED AIR KERMA

Estimated air kerma (radiation output) at distal of cone can be displayed in the exposure time window by depressing the patient switch for more than 1 second. Unit for this value is mGy and this value is calculated by mA, Exposure time and Cone type selected at that time.

Patient type display lamps and displayed value in the window are flashing in this mode and if either of the manual exposure time adjusting switch is depressed during this mode, accumulated air kerma will be displayed. Accumulated value will be reset when the power switch is turned off or leave the x-ray unit more than 8 minutes without depressing any switch. To return to normal mode, press the patient switch for more than 1 second again.

## [ 6 ] OPTIONAL HAND EXPOSURE SWITCH

An optional hand exposure switch can be connected to the sub controller. Since this exposure switch has a coiled cord, operators can stand in the most suitable position for operation. As controller has separate connector for this exposure switch, both exposure switch ⑱ on the front panel of sub controller and this hand exposure switch can be used.

If local code prohibits use of both, ask installer to disconnect the connector of either switch.

## [ 7 ] DIGITAL IMAGING SYSTEM

No x-ray image receptor is integrated into the BERAY II Model 097 x-ray system. If an image receptor is used with the BELRAY II Model 097, the type and performance of the receptor should be as follows.

- 1.Type of receptor : CCD(charge-coupled device), CMOS(complimentary metal oxide semi-conductor) or PSP (photostimulable phosphor plate) receptor for dental intraoral use.
- 2.Adequate amount of x-radiation for the receptor should be between 0.02mGy and 23.6mGy.
- 3.Use the receptor holder and receptor cover recommended by the manufacturer of image receptor.
- 4.Receptor holder should hold the image receptor firmly in position and work as the x-ray beam alignment device.

### WARNING

**The use of ACCESSORY equipment not complying with the equivalent safety requirements of the BELRAY II Model 097 may lead to a reduced level of safety of the resulting system. Consideration relating to the choice shall include :**

- use of the accessory in the PATIENT VICINITY
- evidence that the safety certification of the ACCESSORY has been performed in accordance to the appropriate IEC60601-1 and/or IEC60601-1 harmonized national standard.

## [ 8 ] DISINFECTION AND CLEANING

### 1. DISINFECTION

- (a) X-ray operators are required to wear disposable gloves when taking radiographs and handling contaminated film packets or digital detector cover. Gloves should be changed for each patient to avoid cross contamination. X-ray head, main controller and sub controller should be covered by single use barriers.
- (b) If you use film holders or digital detector holders that go into patient's mouth, properly sterilize them. Follow the sterilization procedures indicate by each manufacturer.

### 2. CLEANING

In order to ensure proper hygiene and cleaning of the equipment, the following procedures must be followed.

### CAUTION

**Before cleaning the unit, turn off the main power switch and breaker on the branch line. This is required because some internal parts remain connected to main voltage even when the main power switch has been turned off.**

**Never use the corrosive disinfectants, such as povidone iodine or sodium hypochlorite.**

**Do not pour or spray solvent or liquid directly on the x-ray unit.**

**Be careful not to allow solvents to run or drip into the x-ray unit.**

**Limitations on reprocessing :** Repeated processing has minimal effect on these instruments.

End of life normally determined by wear and damage due to use.

**Point of use :** Remove excess soil with disposable cloth / paper wipe.

**Preparation for cleaning :** Turn off the main power switch and breaker on the branch line. Disassembly is not required.

**Cleaning :** Wipe the outside surface with a paper towel dampened with a disinfectant solution or household, non abrasive cleaner.

**Disinfection :** To ensure proper cleaning of the parts that may come in contact with skin, periodic disinfection with a non corrosive surface disinfectant is recommended.

Recommended disinfectant : FD333 (Durr Dental), OPTIM33TB (SciCan Ltd.)

**Drying :** Allow surface to air dry before turning breaker and main switch back on.

## [ 9 ] ERROR CODES

If an abnormal condition exists in the unit, or a malfunction occurs, an error code is displayed in the Exposure Time Display Window (16). Please refer to the Table below.

Error Code	Condition	Step to be Taken	Possible Solution
E.00	Exposure switch was released before exposure termination.	All the tooth selection lights blink. Depress one of the tooth switches.	Release the exposure switch after the exposure light turns off.
E.01	Exposure switch was depressed within 10 sec. of previous exposure.	A 10 sec. delay is built in between each exposure.  Release the exposure switch.	There should be a "wait" interval of 50 times the exposure time between successive exposures.
	Exposure time was set and exposure switch was depressed within 3 sec. of the power switch being turned on.		Wait a minimum 3 sec. after the main power switch is turned on before pressing the exposure switch.
E.02	Line voltage was less than 90% of rated voltage.	Release the exposure switch.	Confirm the ready lamp is ON before exposure. Ask service personnel to check the line voltage.
E.03	Line voltage was more than 110% of rated voltage.		Confirm the ready lamp is ON before exposure. Ask service personnel to check the line voltage.
E.04	Excess current during exposure.	Turn off the main power switch and wait for approximately 2 min. Turn on the main power switch again.	Contact customer service
E.05	Tube current at last portion of exposure was less than 3 mA at 4 mA setting or less than 5.25 mA at 7 mA setting.		If same error code is displayed, call service personnel.
E.06	Tube current at last portion of exposure was more than 5 mA at 4 mA setting or more than 8.75 mA at 7 mA setting.		
E.07	During the exposure, tube current becomes less than 2 mA at 4mA setting or less than 3.5 mA at 7 mA setting.		
E.08	During the exposure, tube current becomes more than 6 mA at 4mA setting or more than 10.5 mA at 7 mA setting.		
E.09	Malfunction of the microcomputer.		
E.10	Exposure switch or exposure circuit had been ON, when main power switch is turned on.	Release all the switches	
E.11	Tube current is detected during pre-heating period.	Turn off the main power switch and wait for approximately 2 min. Turn on the main power switch again.	Contact customer service
E.12	Tube current is detected when main power switch is turned on.		

Error Code	Condition	Step to be Taken	Possible Solution
E.22	Failure of electrical communication between the power PCB and timer PCB.	Turn off the main power switch and wait for approximately 2 min. Turn on the main power switch again.	Contact customer service
E.23	Any switch on the sub controller is depressed when the main power switch is turned on. (Except the exposure switch)	Release all the switches	Do not turn on the power while other switch is depressed.

## [ 10 ] MAINTENANCE

The BELRAY II MODEL 097 x-ray unit requires post installation confirmation and periodic maintenance checks to be performed by dealer service personnel. These procedures ensure that the x-ray unit is functioning within the manufacture’s specifications and remains in compliance with the Standard.

It is responsibility of the owner of the unit to see that these maintenance checks are done **once a year** and that they are performed by a trained, certified service technician.

The specific instructions to perform these checks are located within the BELRAY II MODEL 097 Installation Manual.

- A. Line voltage confirmation
- B. Tube current confirmation
- C. Inspection of arm and head movement
- D. Mechanical safety
  1. The wall plate should be checked to confirm that it is securely attached to the wall.
  2. The arm mounting bracket should be checked to confirm that it is securely attached to the wall mounting plate. The arm mounting bracket must be level horizontally and vertically.
  3. Check and verify that the horizontal arm is not raising up and out of the arm mounting bracket.  
This should be verified routinely by treatment room personnel.

## [ 11 ] DISPOSAL

1. Disposal of x-ray unit or components  
The tube head of this x-ray unit contains the lead for x-ray shield and oil for insulation. When disposing the x-ray unit or components, appropriately dispose complying with all current applicable regulations and local codes.
2. Disposal of used film and CCD cover  
Dispose the used film covers and CCD sensor covers appropriately, according to precedures indicatated by each manufacturer and all current applicabel regurations and local codes.

## [12] TECHNICAL DATA

1. X-ray tube .....	Toshiba D-0712 (Stationary Anode)	
a. Nominal focal spot value .....	0.7 (IEC60366)	
b. Target material .....	Tungsten	
c. Target angle .....	16°	
d. Maximum anode heat content .....	4.3kJ (6kHU)	
2. Maximum x-ray tube assembly heat content .....	150kJ (210kHU)	
3. Rated peak tube potential .....	70 kVp	
4. Rated tube current .....	4 mA / 7 mA selectable	
5. Maximum rated peak tube potential .....	70 kVp	
6. Rated line voltage .....	120 V AC, 60Hz , Single Phase, 12 VA (Long term rating) 0.8 kVA (Momentary rating)	
7. Line voltage range .....	108 V AC ~ 132 V AC	
8. Range of line voltage regulation .....	0 ~ 3 %	
9. Rated line current.....	6.5 A at 70 kVp, 7 mA	
10. Maximum line current .....	7.2 A at 70 kVp, 7 mA	
11. Exposure time .....	0.02 ~ 3.2 sec.(ON and OFF are zero crossed)	
12. Inherent filtration .....	1.7 mm Al Equivalent	
13. Added filtration .....	0.5 mm Al	
14. Minimum filtration permanently in useful beam .....	2.2 mm Al Equivalent at 70 kVp	
15. Nominal roentgen output	4mA    7mA	
a. Distal end of regular cone .....	4.2	7.1 mGy/sec. ± 40 %
b. Distal end of long cone .....	1.9	3.3 mGy/sec. ± 40 %
(Data obtained by direct measurement in the useful beam)		
16. Nominal electrical output of H. V. Generator.....	0.36kW at 70kVp, 7mA	
17. Cone	Source to skin distance	Field size
a. Regular cone .....	8 inches (204 mm)	58 mm dia., circular
b. Long cone (option) .....	12 inches (305 mm)	58 mm dia., circular
18. Maximum symmetrical radiation field .....	60 mm dia. at distal end of cone	
19. Leakage technique factor .....	70 kVp / 0.14 mA (0.14 mA is maximum rated continuous current for 7 mA with a duty cycle 1: 50)	
20. Duty cycle .....	1: 50 (0.5 sec. exposure with 25 sec. interval)	
21. Maximum deviation of tube potential, tube current and exposure time		
a. Below 0.1sec. setting .....	± 10 kVp, ± 2 mA, ± 1pulse	
b. 0.1sec. setting & up .....	± 8 kVp, ± 1 mA, ± 1pulse	
22. Measurement base of technique factors		
a. peak tube potential .....	Peak tube potential of conducting half cycle	
b. tube current .....	Average of tube current during one cycle of line frequency	
c. exposure time .....	Impulses of power line frequency	
23. Half value layer .....	1.5 mm Al over	
24. Source to the base of cone distance .....	81 mm	
25. Environmental condition for storage .....	-20 ~ 70°C, 10 ~ 100%, 500 ~ 1060hPa	
26. Environmental condition for operation .....	10 ~ 40°C, 30 ~ 70%, 700 ~ 1060hPa	

## [ 13 ] ELECTROMAGNETIC COMPATIBILITY (EMC)

This product conforms to EMC standard IEC60601-1-2:2014.

### 1. Caution to EMC and Compliance with information in attached document

Medical electrical equipment requires special attention to EMC and it must be installed and used according to the EMC information provided in this instruction manual. Do not install in the vicinity of the electrosurgical device being output or electromagnetically shielded room of ME system for MRI diagnostic imaging because the electromagnetic interference intensity is high.

#### **WARNING**

- a. Use of this equipment adjacent to or stocked with other equipment should be avoided because it should result in improper operation. If such use is necessary, this equipment and the other equipment should be observed to verify that they are operating normally.
- b. Use of accessories, transducers and cables other than those specified or provided by the manufacturer of this equipment could result in increased electromagnetic emissions or decreased electromagnetic immunity of this equipment and result in improper operation.
- c. Portable RF communications equipment (including peripherals such as antenna cables and external antennas) should be used no closer than 30cm (12 inches) to any part of the BELRAY II MODEL 097, including cables specified by the manufacturer. Otherwise, degradation of the performance of this equipment could result.

### 2. Electromagnetic emissions

Emissions test	Test procedure	Compliance	Note : The emissions characteristics of this equipment make it suitable for use in industrial areas and hospitals (CISPR 11 class A). If it is used in a residential environment (for which CISPR 11 class B is normally required) this equipment might not offer adequate protection to radio-frequency communication services. The user might need to take mitigation measures, such as relocating or re-orienting the equipment.
Conducted and radiated RF emissions	CISPR11	Group 1 Class A	
Harmonic distortion	IEC61000-3-2	Class A	
Voltage fluctuations and flicker	IEC61000-3-3	Clause 5	

### 3. Electromagnetic immunity

Immunity test	IEC60601 test level	Compliance level	Electromagnetic environment - guidance
Electrostatic discharge (ESD) IEC61000-4-2	±8 kV contact ±15 kV air	±8 kV contact ±15 kV air	Floors should be wood, concrete or ceramic tile. If floors are covered with synthetic material, the relative humidity should be at least 30%.
Electrical fast transient/burst IEC61000-4-4	±2 kV for power supply lines ±1 kV for input/output lines	±2 kV for power supply lines ±1 kV for input/output lines	Mains power quality should be that of a typical commercial or hospital environment.
Surge IEC61000-4-5	±1 kV differential mode ±2 kV common mode	±1 kV differential mode ±2 kV common mode	Mains power quality should be that of a typical commercial or hospital environment.
Power frequency (50/60Hz) magnetic field IEC61000-4-8	30 A/m	30 A/m	Power frequency magnetic fields should be at levels characteristic of a typical location in a typical commercial or hospital environment.

Immunity test	EN 60601 test level	Compliance level	Electromagnetic environment -
Voltage dips, short interruptions and voltage variations on power supply input lines IEC61000-4-11	<u>dips</u> 0 %Ut: 0.5 cycle (0,45,90,135,180,225,270 and 315 degree) 0 %Ut: 1 cycle (0 degree) 70 %Ut: 25/30 cycles (0 degree) <u>short interruptions</u> 0 %Ut: 250/300 cycles Ut: Rated voltage of EUT	<u>dips</u> 0 %Ut: 0.5 cycle (0,45,90,135,180,225,270 and 315 degree) 0 %Ut: 1 cycle (0 degree) 70 %Ut: 25/30 cycles (0 degree) <u>short interruptions</u> 0 %Ut: 250/300 cycles Ut: Rated voltage of EUT	Mains power quality should be that of a typical commercial or hospital environment. If the user of the BELRAY II MODEL 097 x-ray requires continued operation during power mains interruptions, it is recommended that the BELRAY II MODEL 097 x-ray be powered from an uninterruptible power supply or a battery.
Conducted RF IEC61000-4-6	AC/DC power and Signal input/output 0.15 MHz - 80 MHz: 3V 6 V in ISM bands between 0.15 MHz - 80 MHz (unmodulated, r.m.s.) 80 % AM (1 kHz)	AC/DC power and Signal input/output 0.15 MHz - 80 MHz: 3V 6 V in ISM bands between 0.15 MHz - 80 MHz (unmodulated, r.m.s.) 80 % AM (1 kHz)	Portable RF communications equipment (including peripherals such as antenna cables and external antennas) should be used no closer than 30cm (12 inches) to any part of the BELRAY II MODEL 097, including cables specified by the manufacturer. Otherwise, degradation of the performance of this equipment could result.
Radiated RF IEC61000-4-3	80 MHz - 2700 MHz: 3V/m (unmodulated, r.m.s.) 80 % AM (1kHz)	80 MHz - 2700 MHz: 3V/m (unmodulated, r.m.s.) 80 % AM (1kHz)	
Proximity fields from RF wireless communication equipment IEC61000-4-3	385 MHz 27 V/m (unmodulated, r.m.s.) Pulse modulation 18 Hz	385 MHz 27 V/m (unmodulated, r.m.s.) Pulse modulation 18 Hz	
	450 MHz 28 V/m (unmodulated, r.m.s.) FM ± 5 kHz deviation 1 kHz sine or Pulse modulation 18 Hz	450 MHz 28 V/m (unmodulated, r.m.s.) FM ± 5 kHz deviation 1 kHz sine or Pulse modulation 18 Hz	
	710 MHz, 745 MHz, 780 MHz 9 V/m (unmodulated, r.m.s.) Pulse modulation 217 Hz	710 MHz, 745 MHz, 780 MHz 9 V/m (unmodulated, r.m.s.) Pulse modulation 217 Hz	
	810 MHz, 870 MHz, 930 MHz 28 V/m (unmodulated, r.m.s.) Pulse modulation 18 Hz	810 MHz, 870 MHz, 930 MHz 28 V/m (unmodulated, r.m.s.) Pulse modulation 18 Hz	
	1720 MHz, 1845 MHz, 1970 MHz 28 V/m (unmodulated, r.m.s.) Pulse modulation 217 Hz	1720 MHz, 1845 MHz, 1970 MHz 28 V/m (unmodulated, r.m.s.) Pulse modulation 217 Hz	
	2450 MHz 28 V/m (unmodulated, r.m.s.) Pulse modulation 217 Hz	2450 MHz 28 V/m (unmodulated, r.m.s.) Pulse modulation 217 Hz	
	5240 MHz, 5500 MHz, 5785 MHz 9 V/m (unmodulated, r.m.s.)	5240 MHz, 5500 MHz, 5785 MHz 9 V/m (unmodulated, r.m.s.)	

#### 4. Essential performance

Unless the exposure switch is pressed, x-ray is not exposed.

If the Essential performance is lost or deteriorated, the device may operate inadvertently and may harm the patient, the operator, and the surrounding people.

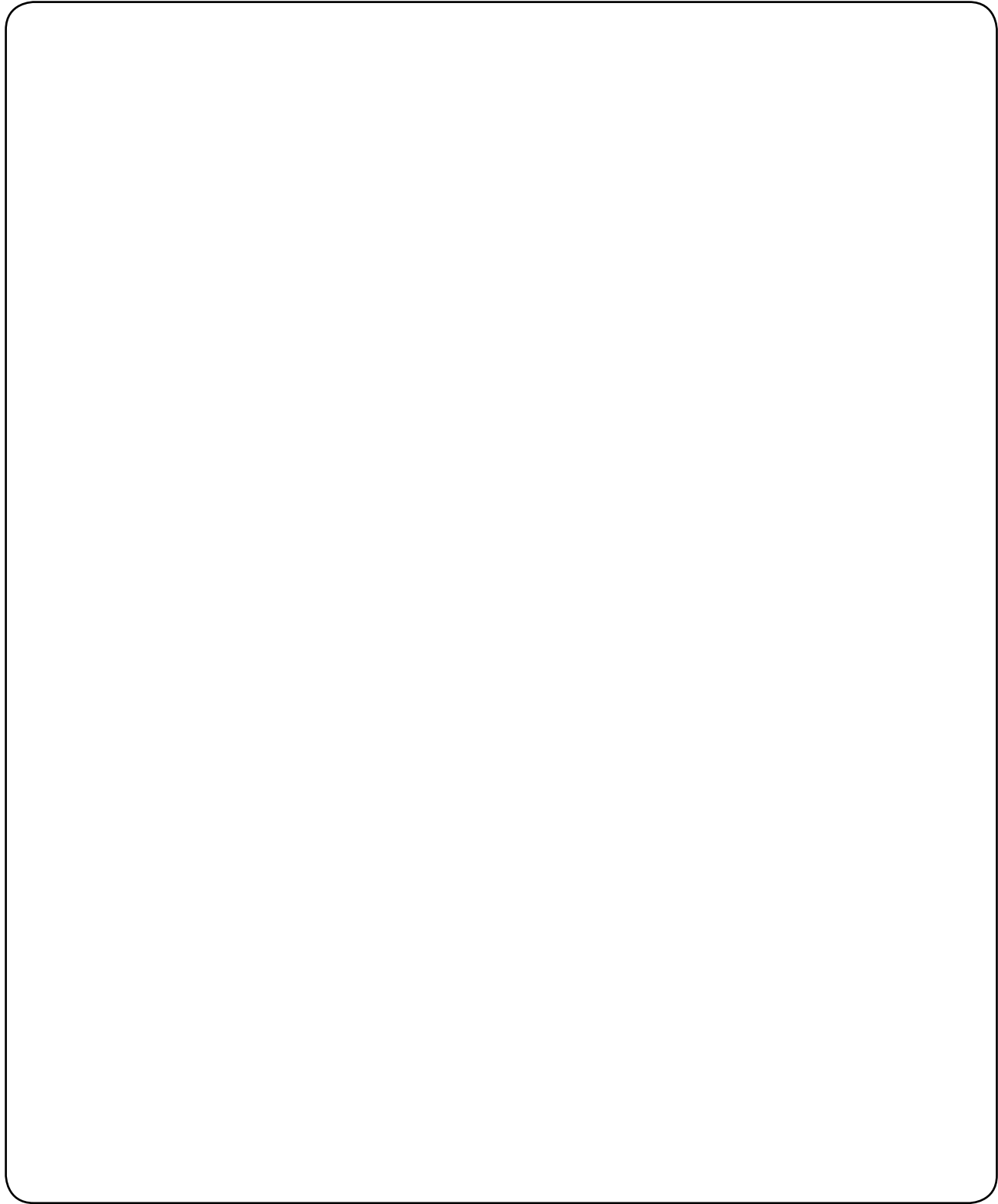

**BELMONT EQUIPMENT, Division of Takara Belmont, USA, Inc.**  
101 Belmont Drive Somerset, New Jersey 08873 U.S.A. TEL.:(732) 469-5000 / (800) 223-1192 Fax.:(732) 526-6322 / (800) 280-7504  
[www.belmontequip.com](http://www.belmontequip.com)

**TAKARA COMPANY, CANADA, LTD.**  
2455 Meadowvale Boulevard, Mississauga, Ontario, L5N 5S2, Canada TEL.:(905) 816-8965 Fax.:(905) 816-8999  
[www.belmont.ca](http://www.belmont.ca)