

DENTAL LIGHT
CLESTA LED DENTAL LIGHT

TYPE 320X

**INSTALLATION
INSTRUCTIONS**

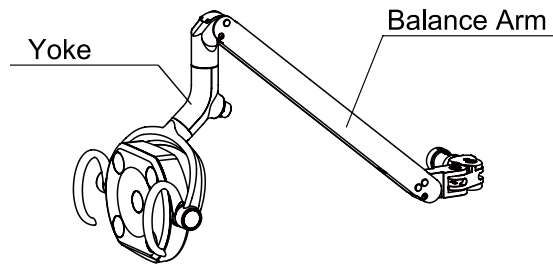

TABLE OF CONTENTS

Precautions for Installation	1
Overview and Major Components	1
Specifications & Dimensions	2
Installation Instructions	3~8
Adjustment	8~9
Wiring Diagram	10
Flow Diagram	11

1. Precautions for Installation

1. During lifting of the dental light, make sure to hold the yoke and the balance arm described as follows. If not, it may lead to physical injury or property damage.



2. Do not drop or hit the product.
3. Do not connect the power supply other than rated voltage.
4. Be sure to adjust the leveling of the unit and chair to prevent from drifting of the dental light.
5. When the installation process has been completed, Check that all the mechanical and electrical functions are working properly.

WARNING

The LED is very bright. Do not direct the LED beam into the patient's or user's eyes.

2. Overview and Major Components

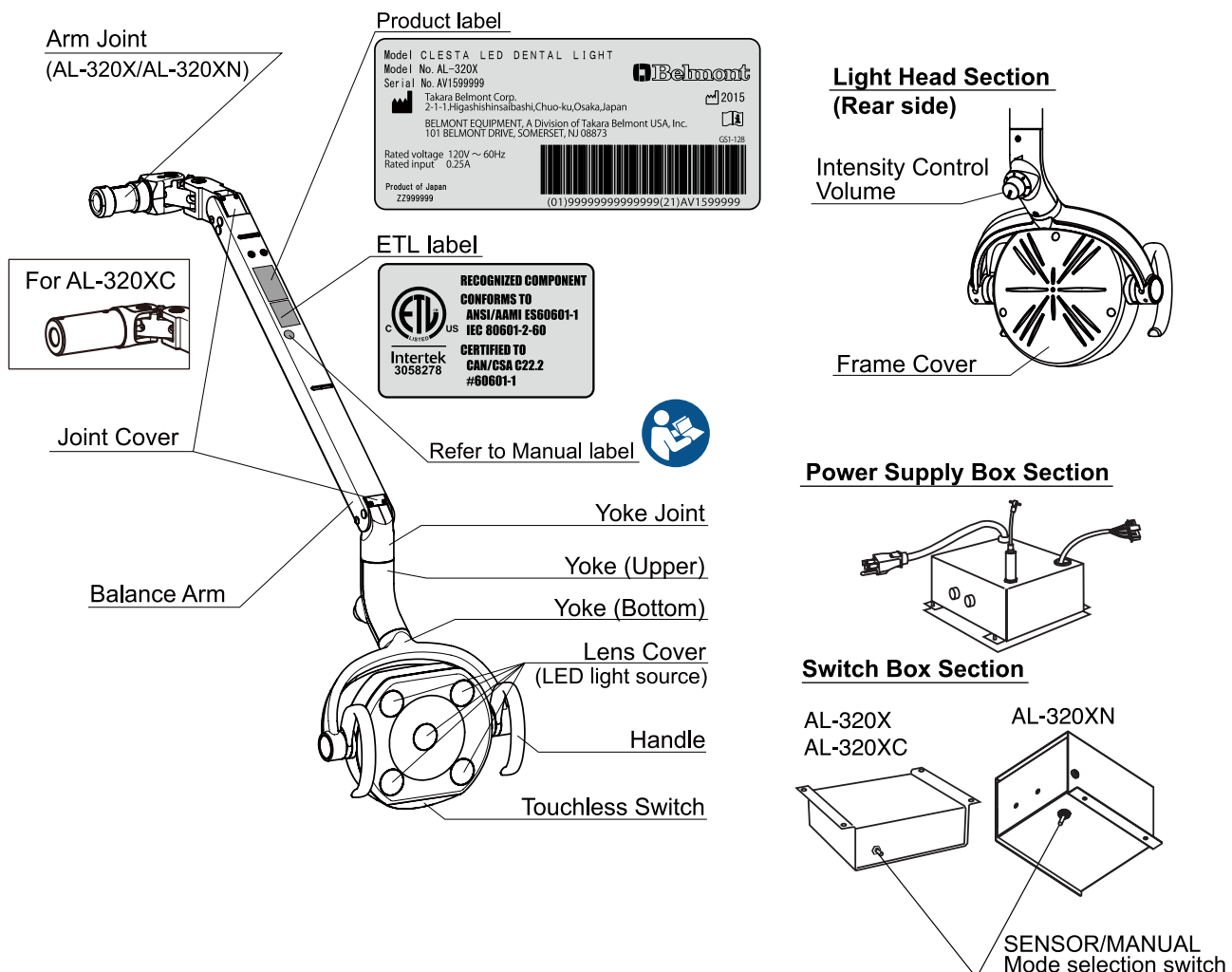

3. Specifications & Dimensions

- **Model No.** : AL-320X (X-Calibur Swing Arm Mount)
: AL-320XN (C-Calibur Cuspidor Mount)
: AL-320XC (Evogue Mount)
- **Rated Voltage** : AC120V 60Hz
- **Rated Input** : 0.25A
- **Fuse** : 0.8A / 250V (Time-lag)
(Breaking capacity 35A / 250VAC)
Size of Fuse 5.0 x 20
- **Weight** : 12.6 lbs (5.7kg)
- **Light Source** : LED (5 LEDs)
- **Optical Performance** : Focal Distance 25.6" (650mm)
: Light Intensity (Normal treatment mode)
3100 Lux / 288 FTC ~ 28000 Lux / 2601 FTC
: Light Intensity (Composite mode) 4300 Lux / 399 FTC
: Correlated Color Temperature 5000K
- **Light Pattern** : 3.3" x 6.1" (85mm x 155mm) at 25.6"
- **Protection class against electric shock** : Class I Equipment.
- **Usage environment** : Temperature 50 ~ 104F (10 ~ 40°C)
Humidity 30 ~ 75%
Air pressure 10.2 ~ 15.4 psi (700 ~ 1060 hPa)
- **Transportation / Storage environment** : Temperature -4 ~ 158F (-20 ~ +70°C)
Humidity 10 ~ 95%
Air pressure 10.2 ~ 15.4 psi (700 ~ 1060 hPa)

● Dimensions

*Values are the standard values. [Unit: inch (mm)]
Dimensional tolerance: ±10%

- AL-320X
- AL-320XN

- AL-320XC
(Same dimentions as AL-320X except figure below)

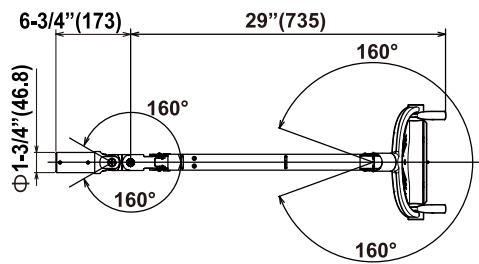
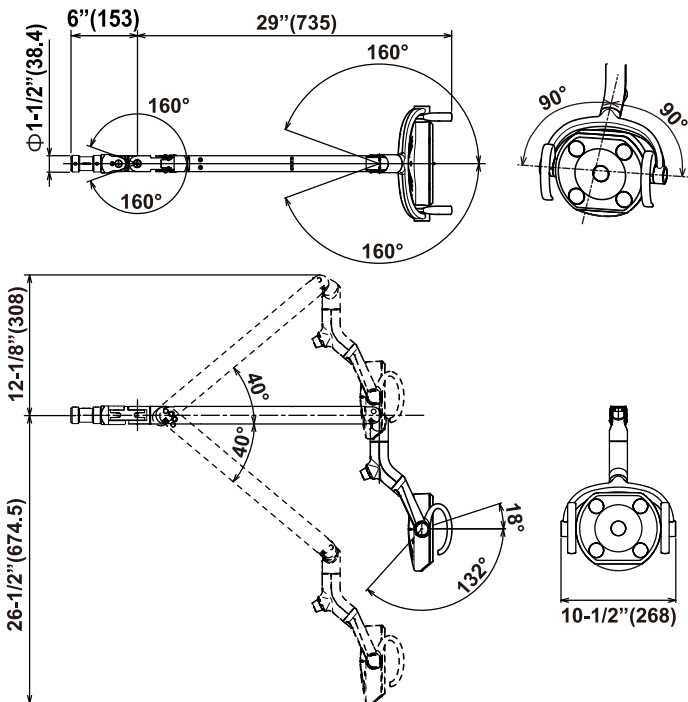

• Switch Box Section

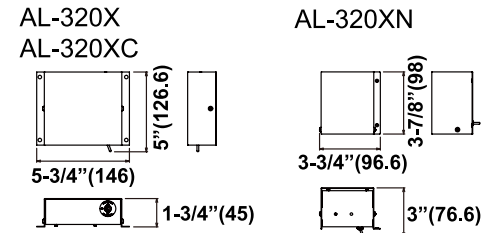

• Power Supply Box Section

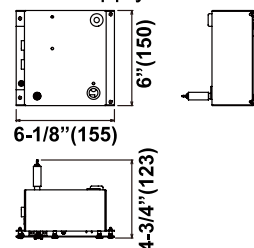

4. Installation Instructions

■ Necessary Tools

Phillips Screw Driver, Metric Allen Wrench Set

■ Attach the light assembly to the light pole

*Refer to the installation manual attached to the dental unit for installation of the light pole.

(1) Remove the M6 button screws (2) from the balance arm joint.

*Be careful not to lose the M6 button screws, it will used again.

(2) Feed the wire harness coming from the balance arm joint through the light pole. Insert the balance arm joint of the light into the light pole. Fix with two M6 button screws (2).

* The light pole is included with the dental unit section.

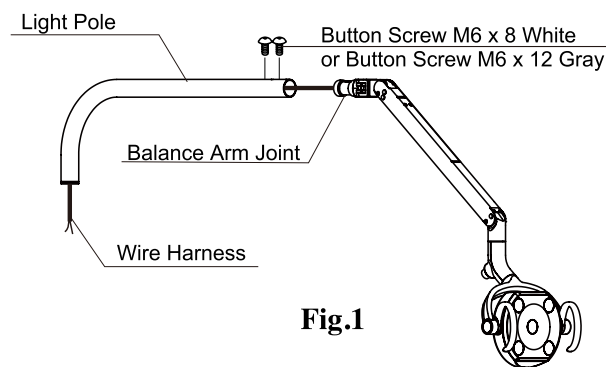

Fig.1

■ Attach the light to the X-Calibur Unit

For Swing Arm Mount

(3) Feed the light assembly wire harness through the swing arm and pull the end of the harness from the lower end of the swing arm. Mount the light pole onto swing arm (Fig.2). Insert the brake disks, set screws in to the light pole and adjust the brake with set screws (Fig.3).

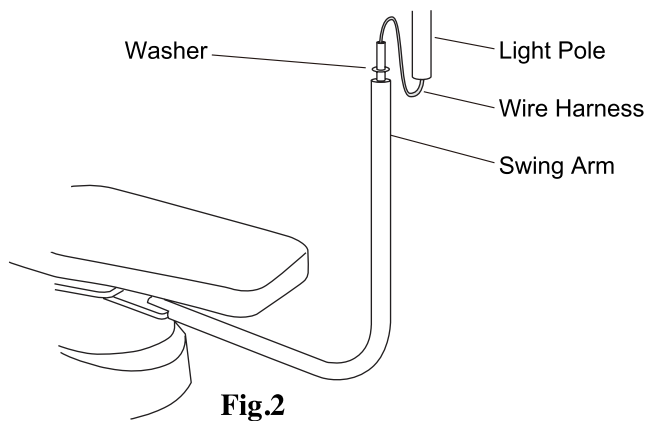

Fig.2

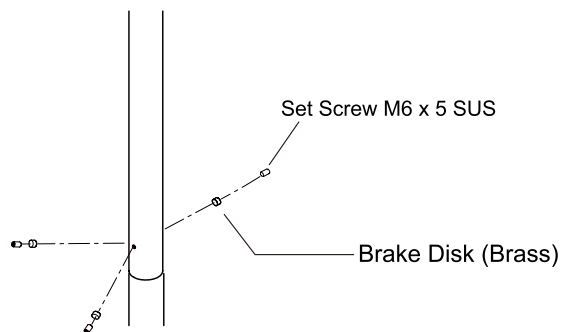

Fig.3

For Cuspidor Mount

(4) Feed the light assembly wire harness through the light support rod (Fig.4) and pull the end of the harness from side of the cuspidor post as below (Fig.5).

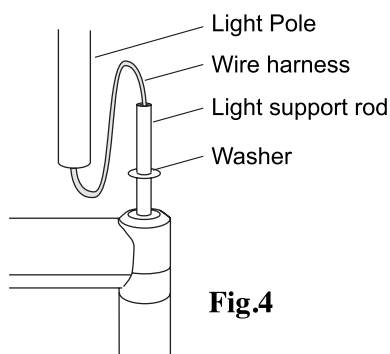

Fig.4

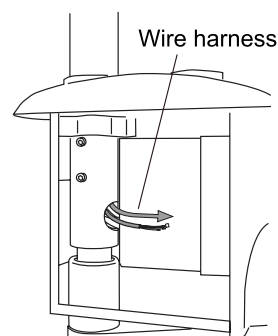

Fig.5

4. Installation Instructions

■ Attach the light to the Evogue Unit

For Swing Arm Mount

- (3) Feed the light assembly wire harness through the swing arm and pull the end of the harness from the lower end of the swing arm. Mount the light pole onto swing arm (**Fig.6**). Insert the brake disks, set screws in to the light pole and adjust the brake with set screws (**Fig.7**).

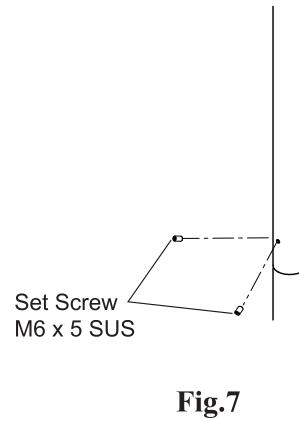
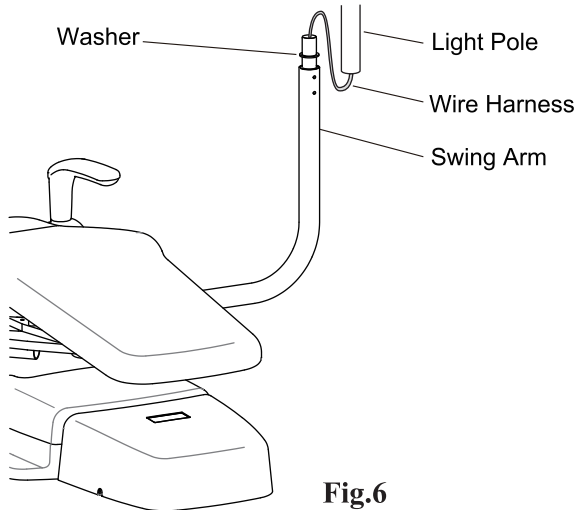

For Cuspidor Mount

- (4) Feed the light assembly wire harness through the light post (**Fig.8**) and pull the end of the harness from side of the cuspidor post as below. Insert the set screws in to the light post and adjust the brake with set screws as shown in **Fig.9**.

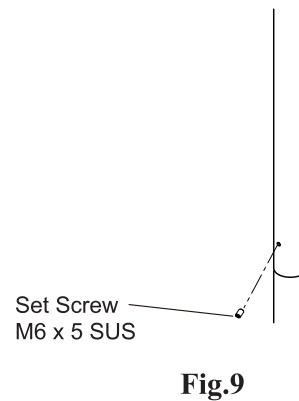
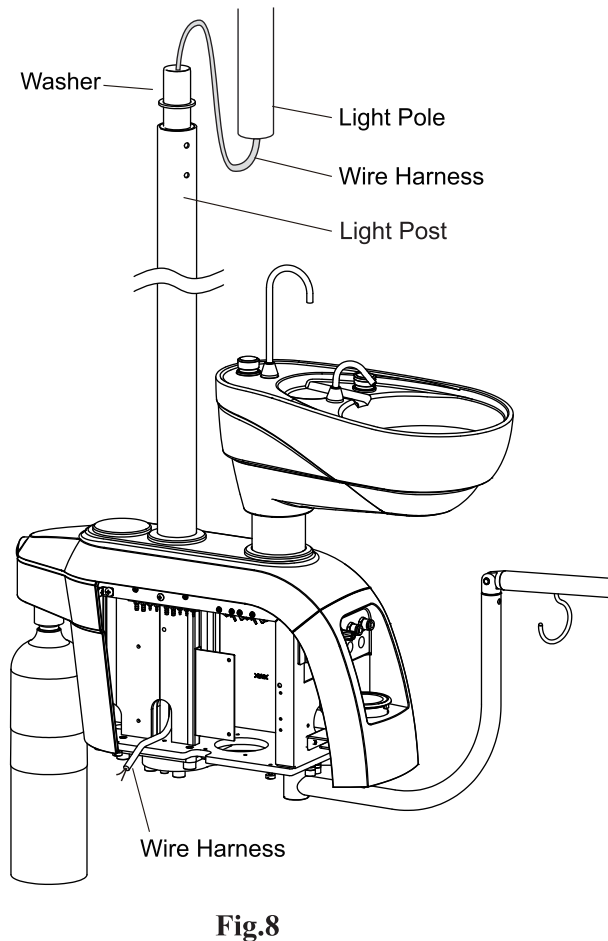

■ Install the Power Supply Box

- (5) Place the power supply box inside J.box. Connect 8P connector of power supply box and wire harness.
Feed the wire harness through the umbilical (**Fig.10**).
For Quolis chair, feed the wire harness to the chair side (**Fig.11**).

Combine with BEL-50 Chair

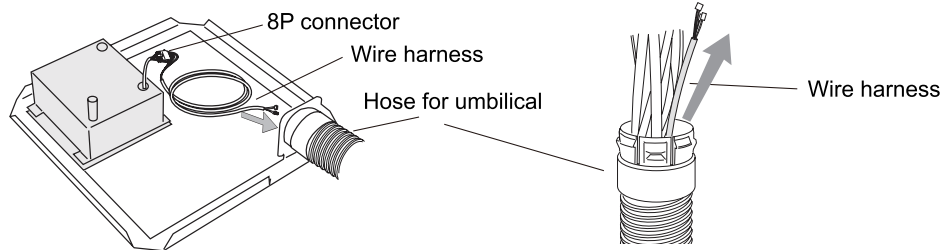

Fig.10

Combine with Quolis Chair (Only for AL-320XC)

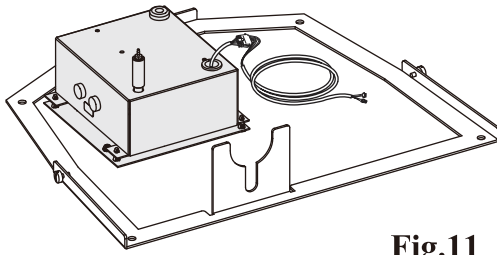

Fig.11

■ Install the Switch Box

- (6) Open the control box and connect the connectors with the wire harness from the light head and the other wire harness from the power supply box. Follow the drawing below (Fig.12).
- (7) Attach the control box as shown in Fig.13 ~ Fig.16.

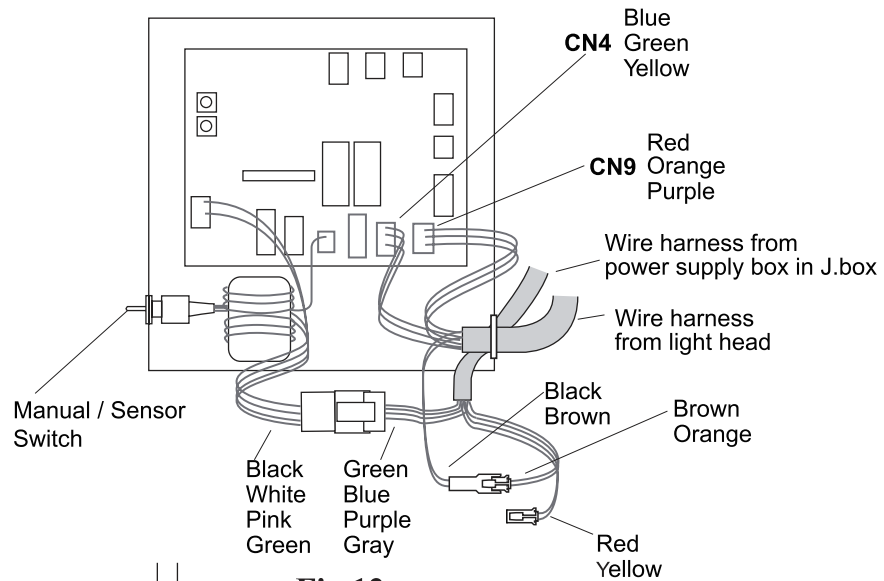

Fig.12

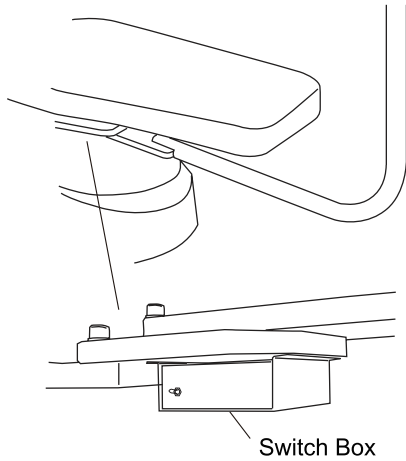

Fig.13. X-Calibur Swing Arm Mount

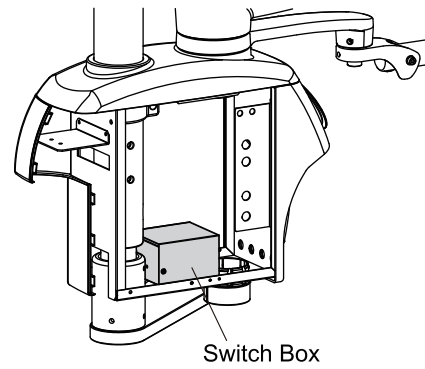

Fig.14. X-Calibur Cuspidor Mount

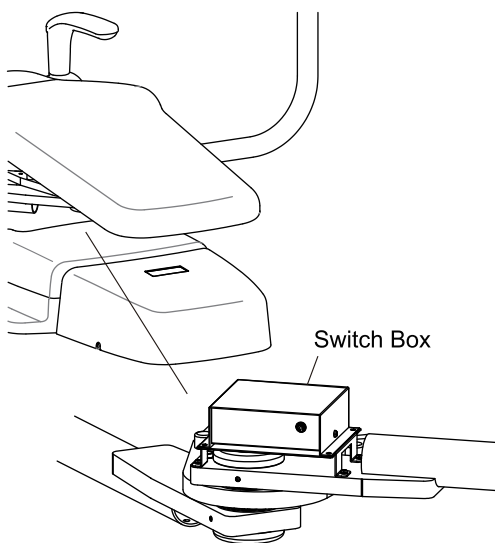

Fig.15. Evogue Swing Arm Mount

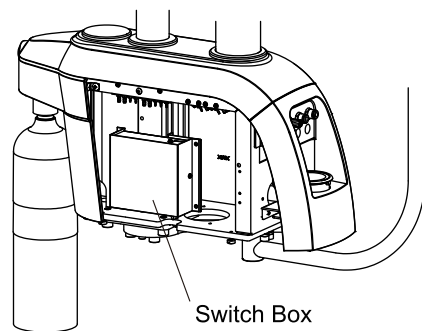

Fig.16. Evogue Cuspidor Mount

■ Connection of power supply box

(8) Connect the wire harness, brown tubing as per the following diagram.

After all the connection is completed, connect the power plug to AC120V (**Fig.17**).

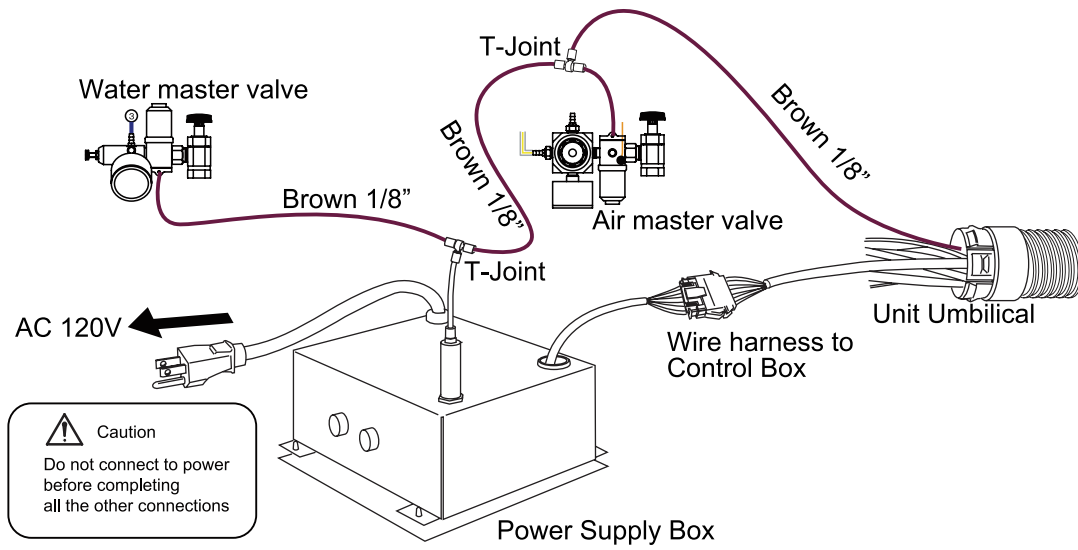

Fig.17

■ Check Operation of the Dental Light

When the installation process has been completed, check that all the mechanical and electrical functions are working properly.

Item	Inspection method	Method of confirmation
Touch-less Sensor	Confirms the light ON and OFF when shake hand within approximately 2-1/2" (65mm) from the touch-less switch.	Operation Check
	Confirms switching the composite mode when hold hand within approximately 2-1/2" (65mm) from the touch-less switch for certain time.	Operation Check
Intensity control volume	During normal treatment mode, make sure the light intensity changes when turning the intensity control volume.	Operation Check
Movement of the Light	Make sure the light head stops and hold any positions. Make sure that no abnormal noise occurs when the product is operated. * At the beginning, light head movement (up/down, rotation) could be tight. This is a normal symptom. As you move light head for three four times, light movement becomes smooth.	Operation Check

⚠ WARNING

The LED is very bright. Do not direct the LED beam into the patient's or user's eyes.

5. Adjustment

After checked operation of the dental light, adjust the dental light if you have following cases

Balance arm doesn't stay at the desired position ⇒ Adjust the tension of the balance arm. Follow instructions
[Adjustment of the tension of the balance arm]

Light head is not vertical position ⇒ Adjust the angle of the light head. Follow instruction
[Adjustment of the angle of the light head]

■ Adjustment of the tension of the balance arm

Position the angle of the balance arm so the tension adjustment nut becomes visible just under slot A.

Turn the nut and adjust the tension with the adjustment bar supplied with the light.(**Fig.18**)

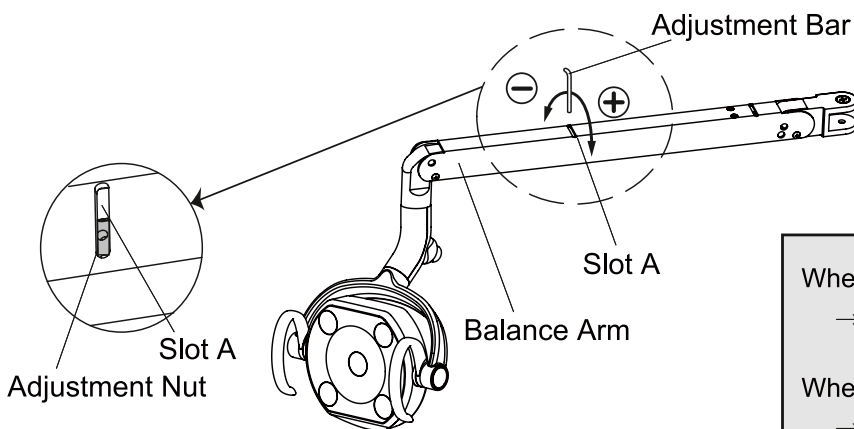

Fig.18

When the light head tends to go up,
→ Turn the nut to ⊕ direction.

When the light head tends to go down,
→ Turn the nut to ⊖ direction.

■ Adjustment of the angle of the light head

Remove the yoke joint cover by removing the two M3 x 6 tapping screws. Move down the balance arm and loosen the set screw on the joint shaft by use of 2mm hex key wrench before adjust the angle of the light head.

(Fig.19)

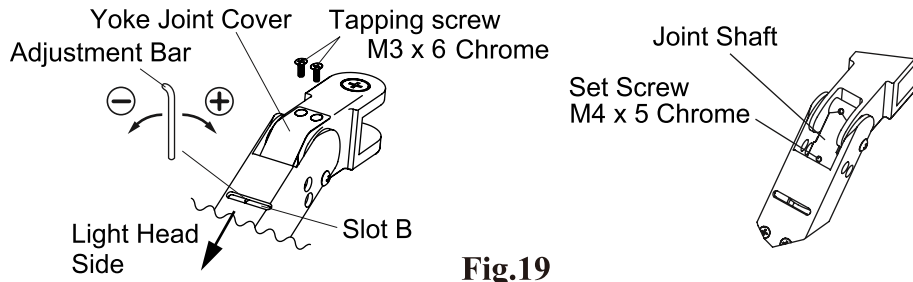

Fig.19

⚠ CAUTION

Turning the adjustment nut without loosen the set screw, it may cause damage to the shaft. Make sure loose the set screw before turning the adjustment nut.

Position the angle of the balance arm so the head angle adjustment nut becomes visible just under the slot B. Turn the nut and adjust the tension with the adjustment bar supplied with the light. (Fig.20)

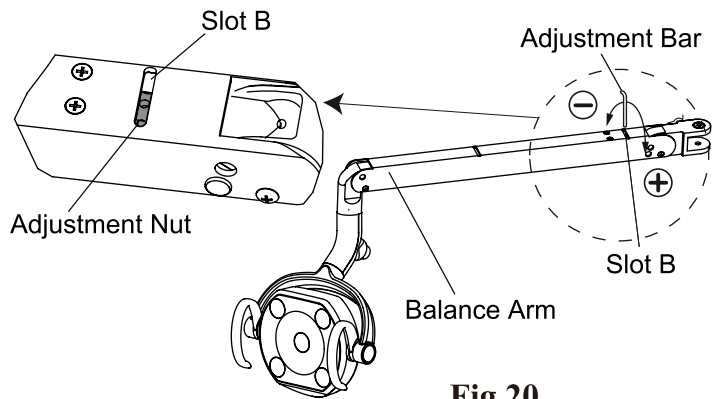
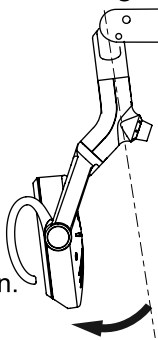

Fig.20

Adjustment of the angle of the light head

When the light head tends to go down,
→ Turn the nut to ⊖ direction.



When the light head tends to go up,
→ Turn the nut to ⊕ direction.

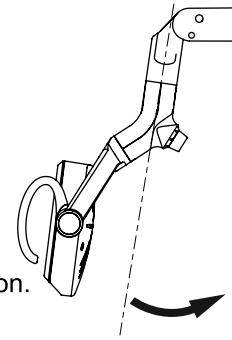

After adjustment is done, re-tighten the set screw by use of 2mm hex wrench. Fix the joint cover with two M3 x 6 tapping screws and insert the joint cover into balance arm.

⚠ CAUTION

Unless this socket screw is re-tightened, the angle of the head will be changed during use.

6. Wiring Diagram

Settings of PCB dip switches (SW3,4) and jumper pin (JP3).

Setting condition	Default setting
1 Test mode (Always OFF) Off: Normal operation, On: Test operation	OFF
2 Transition time to Composite mode (by a sensor) Off: 1 second, On: 2 seconds	ON
3 Wake-up brightness setting from light off condition. Off: 1. Composite Mode when a light is turned on by using a sensor. : 2. Keeps on getting on/off signal from dr table, light stays in composite mode. On: 1. Regular Mode when a light is turned on by using a sensor. : 2. Keeps on getting on/off signal from dr table, light goes into regular mode.	ON
4 Combining dental unit Off: Clair unit, On: CP-One plus	OFF

Setting condition	Default setting
5 Sensor activation setting Off: Activate when a hand goes away. On: Activate when a hand comes in.	OFF
6 Includes Composite Mode Off: Yes, On: No	OFF
7 Speed setting of communication line Off: 4800bps, On: 2400bps	OFF
8 LED blink setting of Composite Mode Off: Slow blinking, On: Rapid blinking	OFF

Setting condition	Default setting
SW4 PC side: Clair Unit, 232 side: CP-One plus	PC
JP3 PC side: Clair Unit, 232 side: CP-One plus	PC

Remarks
 Connector Symbol
 SM ... SM Connector
 XA ... XA Connector
 XM ... XM Connector
 Black dot
 Plug
 The side with black dot has male pins
 Receptacle

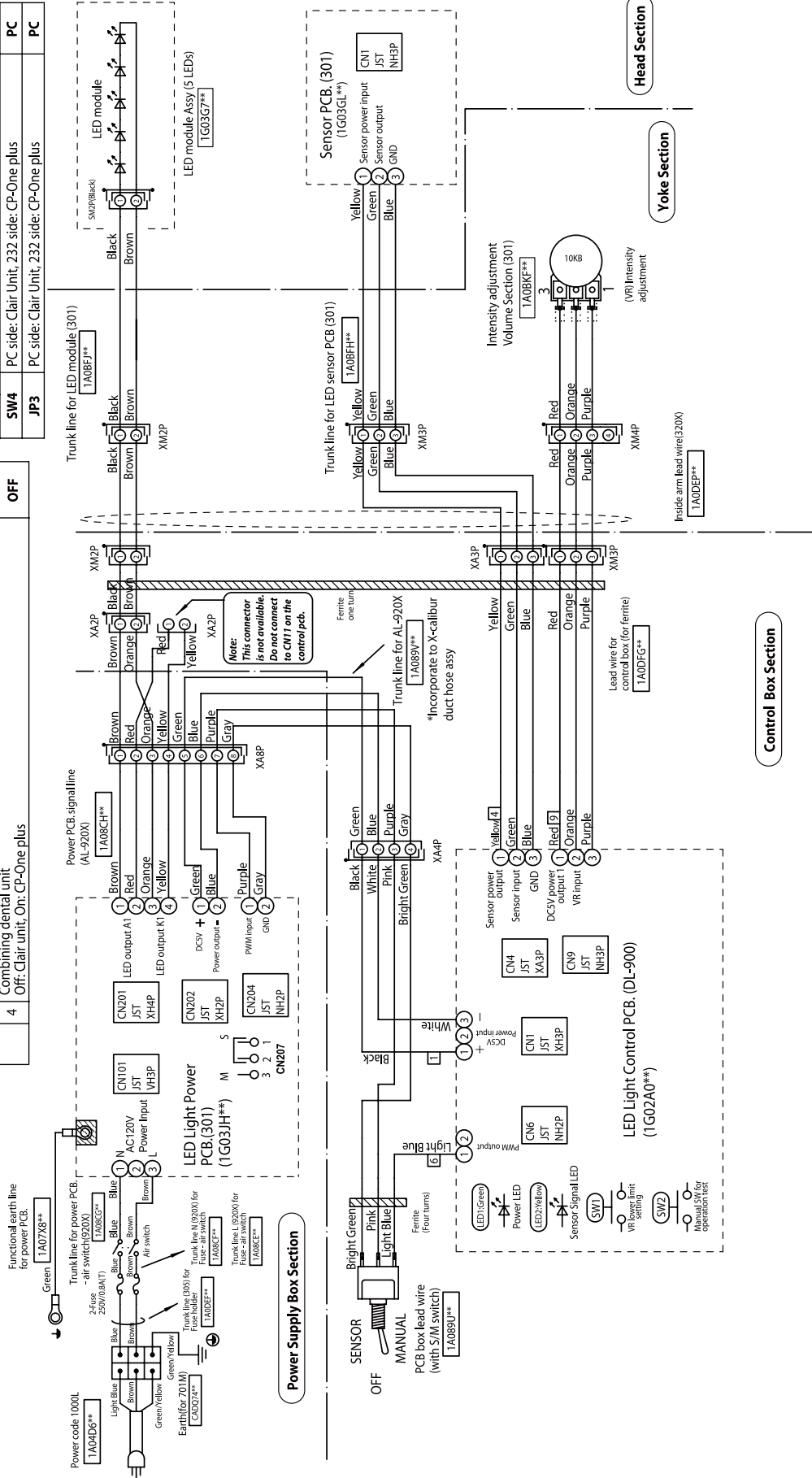

7. Flow Diagram

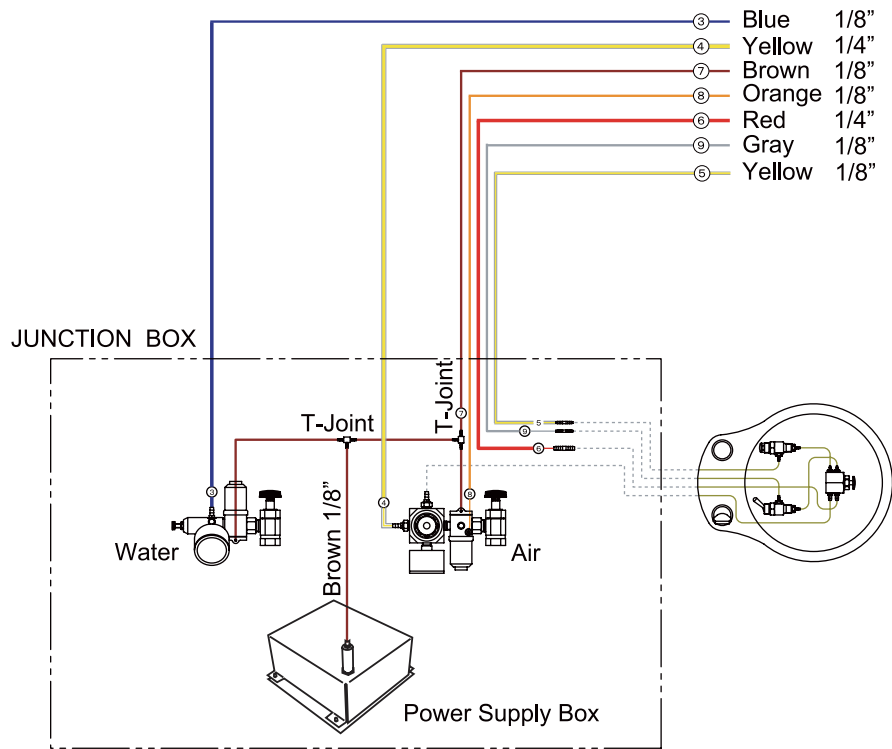

NOTE



BELMONT EQUIPMENT, Division of Takara Belmont USA, Inc.

101 Belmont Drive Somerset, New Jersey 08873 U.S.A. TEL.:(732) 469-5000 / (800) 223-1192 Fax.:(732)356-1035

TAKARA CO, CANADA LTD.

2076 S. Sheridan Way, Mississauga, Ont., L5J2M4, Can. TEL.:(905) 822-2755 Fax.:(905)822-6203



TAKARA BELMONT CORPORATION (Manufacturer)

2-1-1, Higashishinsaibashi, Chuo-ku, Osaka, 542-0083, Japan TEL.: +81-6-6213-5945 FAX.: +81-6-6212-3680