

# D-Series Dental Cabinetry System

Installation Manual

Model: D-4R & D-4RH



1631 Dr. Martin Luther King Drive  
St. Louis, MO 63106  
(314) 231-7383 1-800-325-7373  
Fax (314) 621-2296  
[www.belmontequip.com](http://www.belmontequip.com)

**Model: D4R & D-4RH With Privacy Panel  
Dimensions**

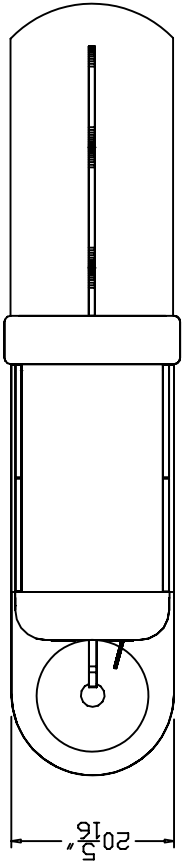

TOP VIEW

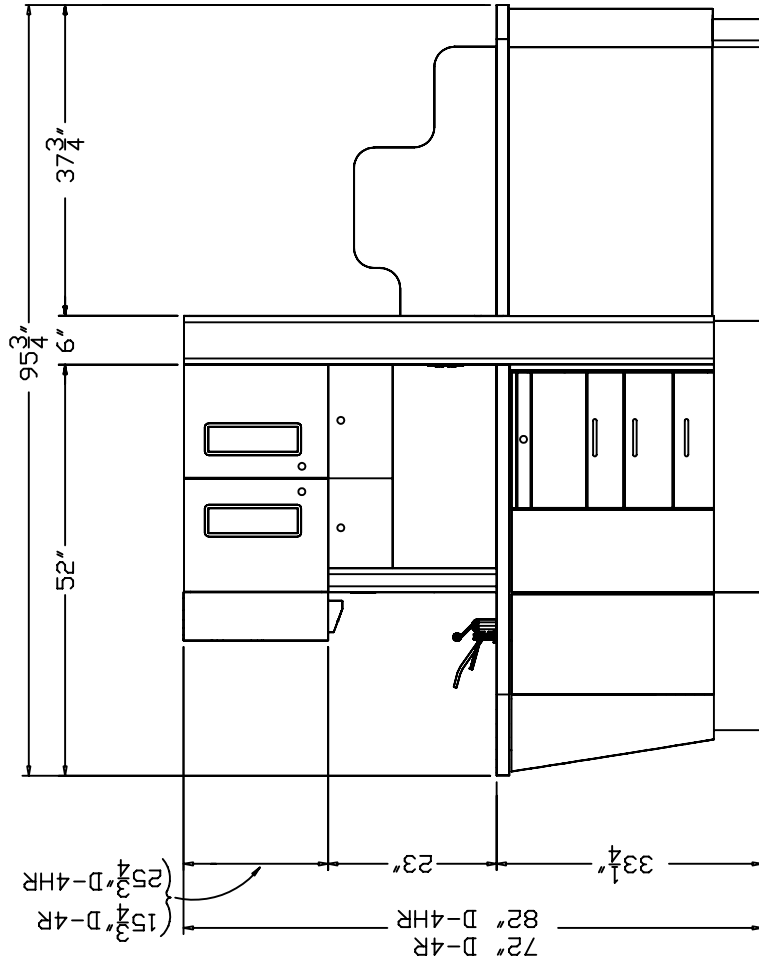

FRONT VIEW

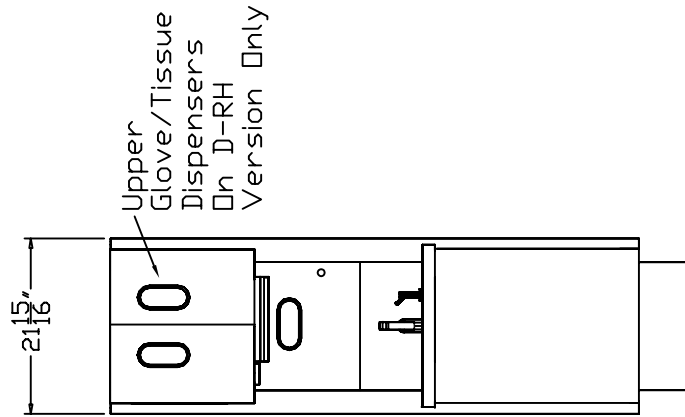

LEFT SIDE VIEW

**Model: D4R & D-4RH With Bi-Fold Doors  
Dimensions**

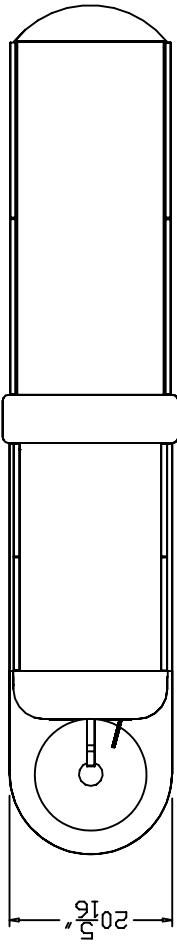

TOP VIEW

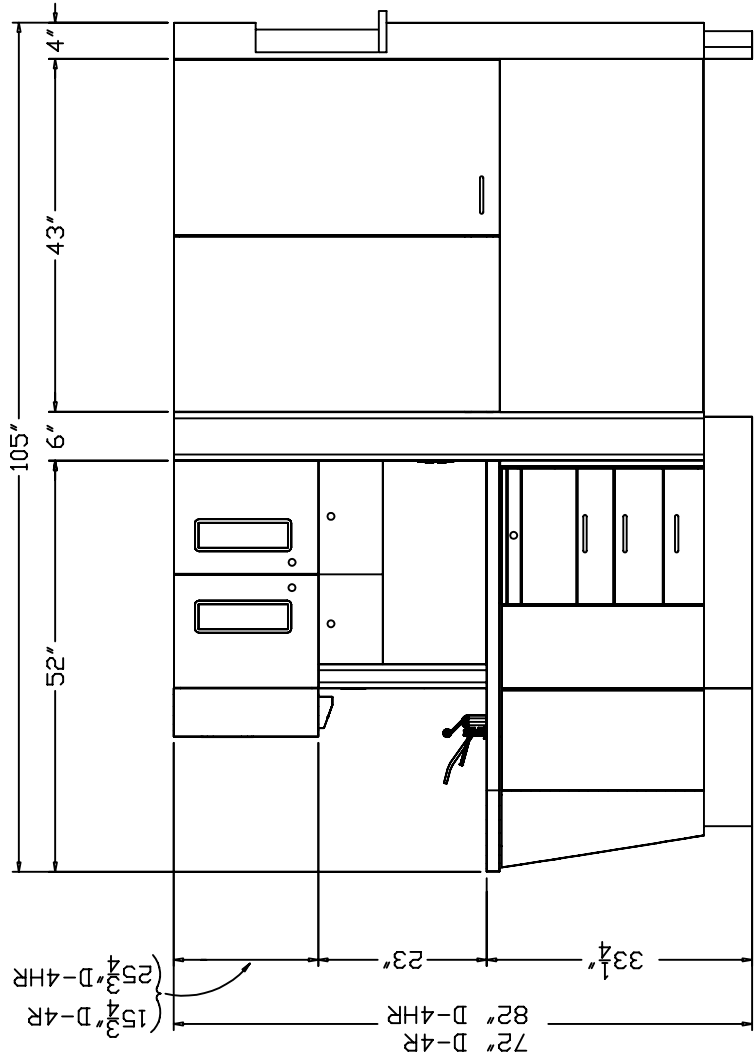

FRONT VIEW

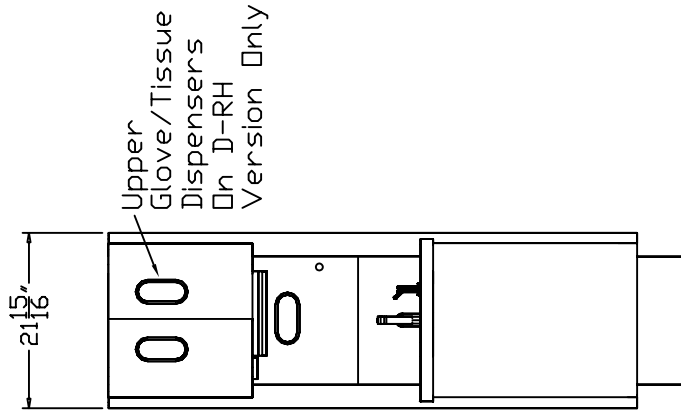

LEFT SIDE VIEW

# D-4R & D-4RH Assembly Instructions

## Component Identification

CABINET DRAWINGS BASED ON THE D-4R VERSION (72" HIGH)

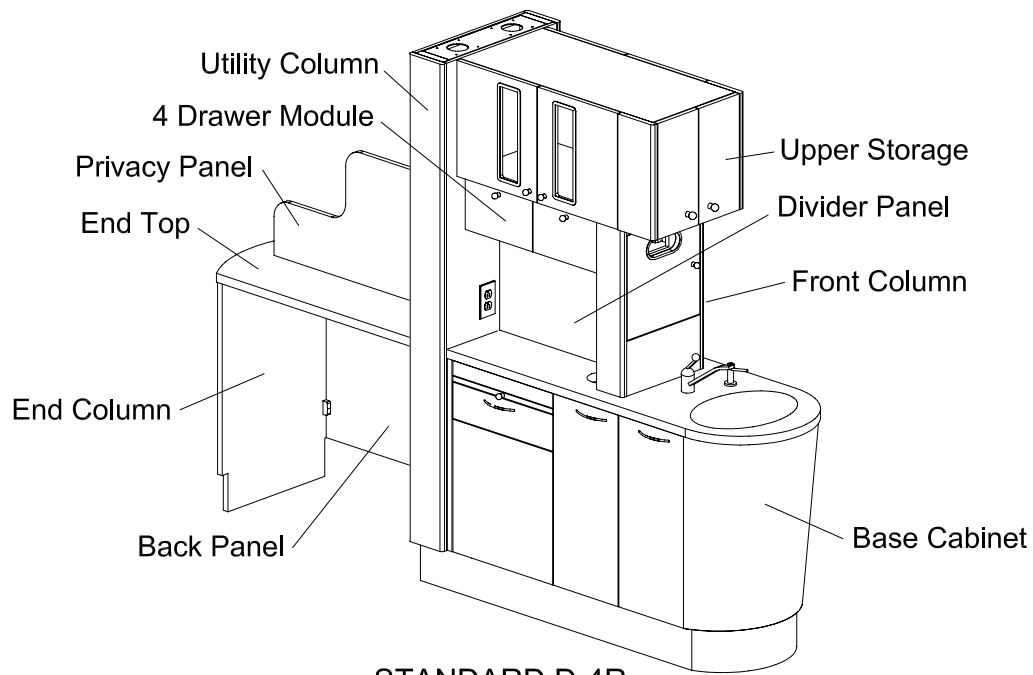

STANDARD D-4R

# D-4R & D-4RH Assembly Instructions

## Step 1

Move the base cabinet into position and check the incoming power and plumbing rough-in locations for proper alignment. Remove the rectangular hole cover on the interior of the base cabinet under the sink section for access to the front floor brackets and leveling feet. Drill the holes in the floor through the floor brackets for securing the base to the floor and secure with proper fasteners. Level unit by using the leveling feet. See Figure 1.

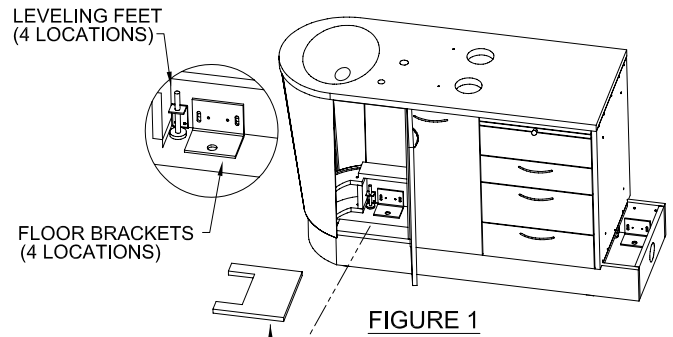

## Step 2A

Remove the drawer on the doctor's side under the bread board and the bottom drawer on the Assistant's side. Place utility column onto rear of base cabinet on top of the exposed kickplate. See Figure 2A.

In the drawer opening on the doctor's side under the bread board drive in (2) 1/4-20 x 1 1/2" RH machine screws, lock washers and washers in the provided holes. See Figure 2B.

In the bottom drawer opening on the assistants side drive (2) 1/4-20 x 1 1/2" RH machine screws with lock washers and washers in the provided holes. See Figure 2C.

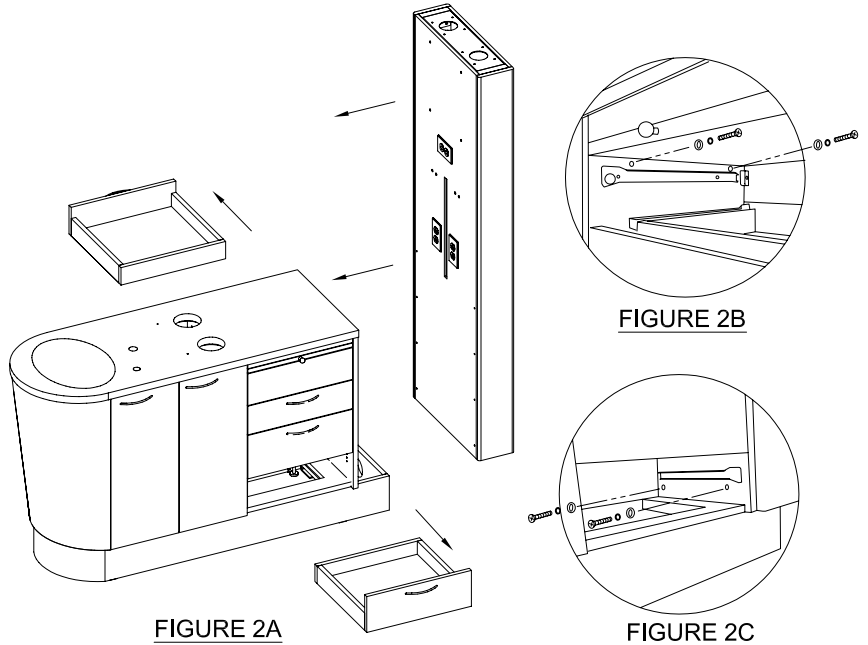

## Step 3

Place the front column and the divider panel onto the cabinet top making sure the divider panel fits in the slot on the utility column and the front column. See Figure 3A.

Open the trash drawer and from underneath the top fasten the front column to the top by using (2) 1/4-20 x 2" RH machine screws with lock washers and washers. See Figure 3B.

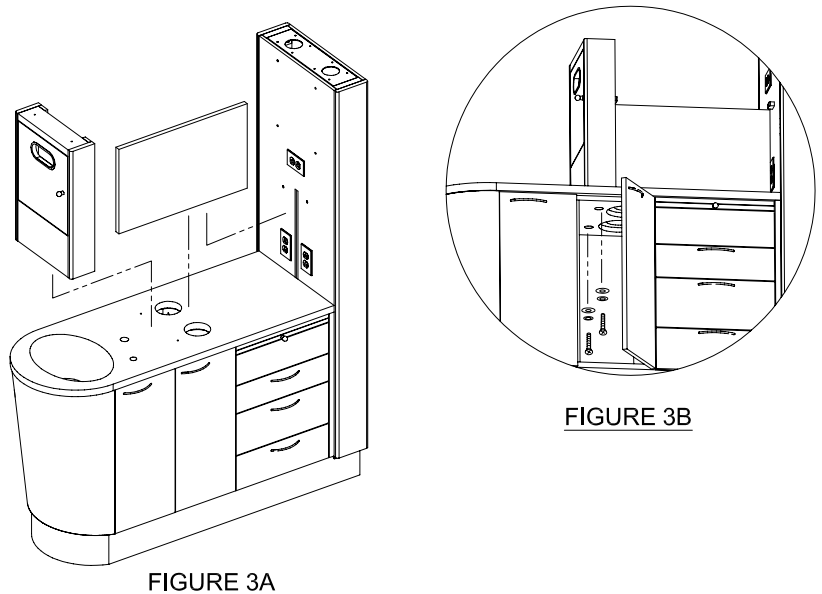

# D-4R & D-4RH Assembly Instructions

## Step 4

Drop the upper flip down door section onto the divider panel making sure the (4) Rafix studs on the utility column and front column insert in the (4) Rafix housings on the bottom of the door module then tighten each one with a screwdriver. See Figure 4A. & Figure 4B.

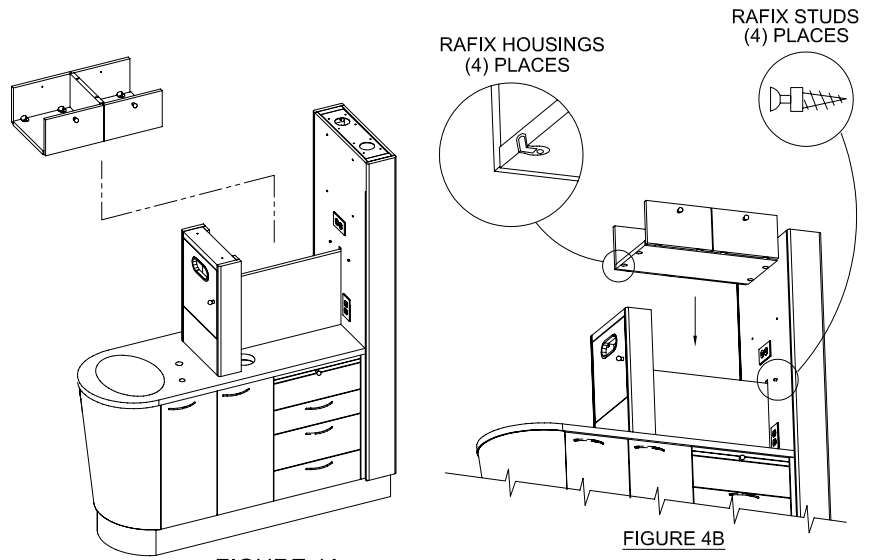

## Step 5

Make sure the (2) Rafix studs are screwed into the bottom of the upper storage. See Figure 5A.

Open the (4) flip down doors mounted to the top of the divider panel then place the upper storage onto the mid section. See Figure 5B. Make sure the (2) Rafix studs insert into the Rafix housings on the top of the flip down door center divider then tighten each one.

Join upper storage to the utility column by fastening (4) 1/4-20 x 1 1/4" joint connector bolts from inside the upper storage. See Figure 5C.

Open the door on the front column and from beneath fasten the upper storage front by using (2) #8 x 1 3/4" FH wood screws. See Figure 5D.

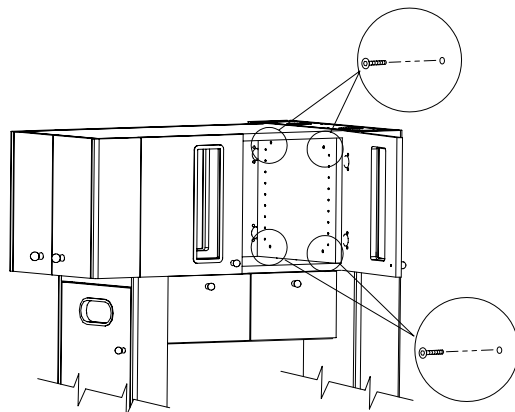
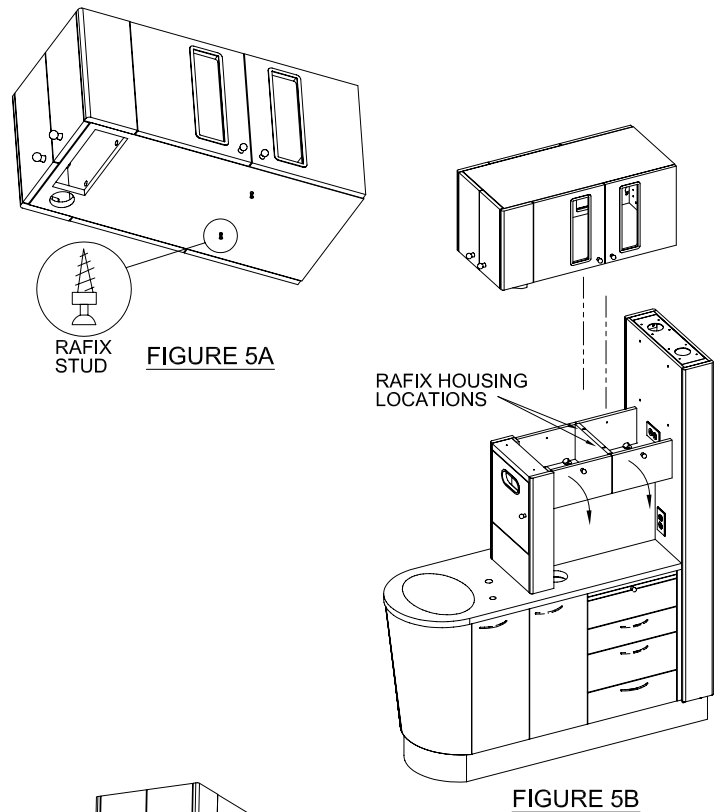

FIGURE 5C

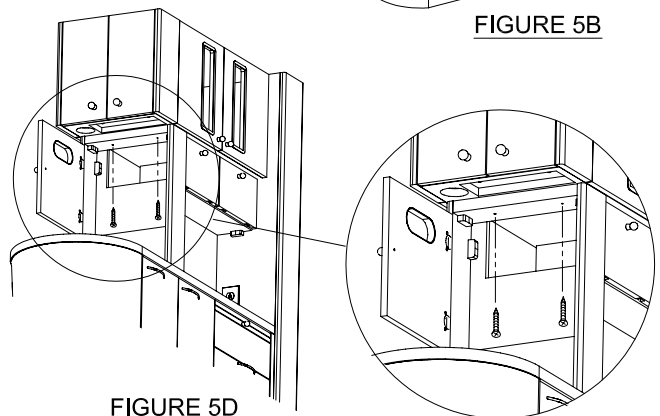
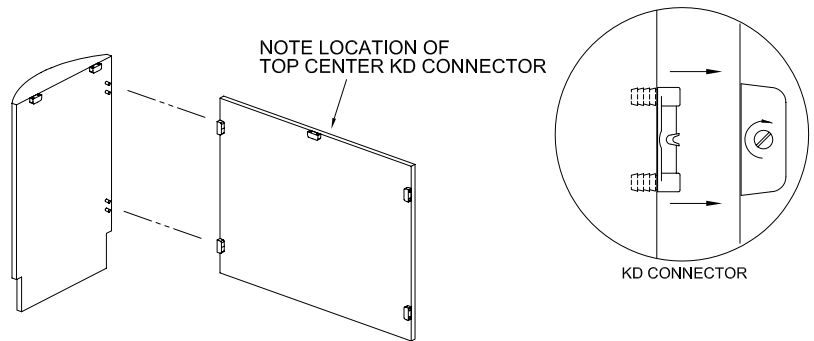

FIGURE 5D

# D-4R & D-4RH Assembly Instructions

## Step 6

Connect the end column with the back panel using the (2) KD connectors. Engage the KD connectors by turning the screw clockwise about 1/2 turn. See Figure 6A.



Connect the column and back panel with the utility column of the main cabinet using the (2) KD connectors. Engage the KD connectors by turning the screw clockwise about 1/2 turn. See Figure 6B.

FIGURE 6A

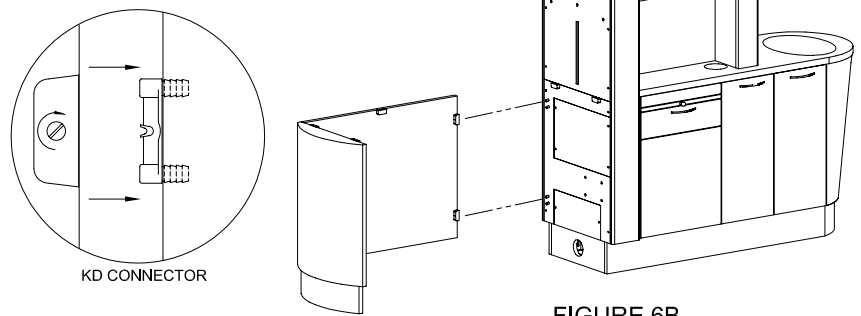

FIGURE 6B

## Step 7

Place the top onto the end column/rear panel and connect the (5) KD connectors. Engage the KD connectors by turning the screw clockwise about 1/2 turn. See Figure 7.

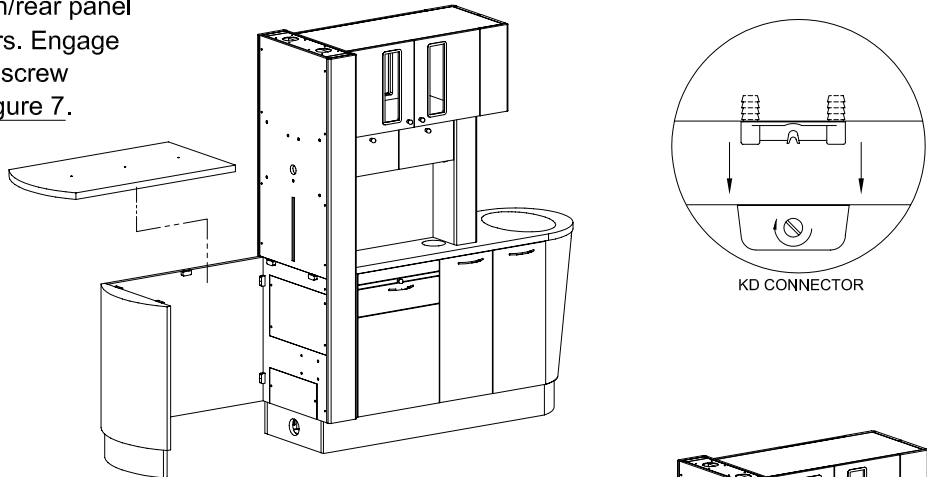

FIGURE 7

## Step 8

Place the privacy panel divider onto the top making sure you seat the end into the groove cut in the utility column. Fasten to the top by screwing in the (3) 1/4-20 x 1 3/4" RH screws with lock washers and washers from underneath the top. See Figure 8.

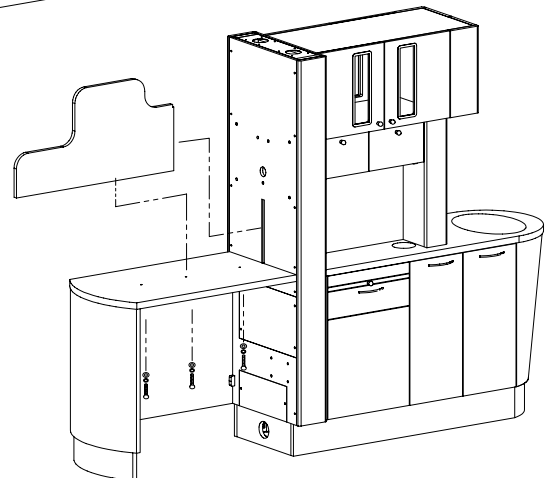

FIGURE 8

# D-4R & D-4RH Assembly Instructions

## Step 9

Open the door on the front column and insert the cup dispenser (cylinder shape) into the hole (with the outward dimples at the top). See [Figure 9](#).

With the door still open in the front column insert (4) glass support pins into desired holes and place (1) 5 1/8" x 15 1/16" glass shelf on support pins. See [Figure 9](#).

Open doors on the upper storage and insert (4) glass support pins into the desired holes for the 14 3/4" x 26 5/8" glass shelf then place the glass shelf onto the support pins. See [Figure 9](#).

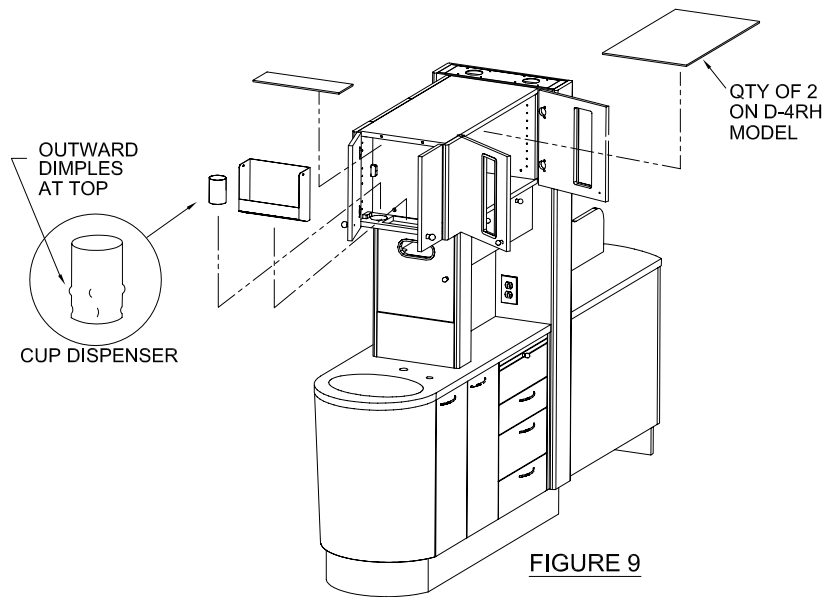

## Step 10

Remove the bottom access panel by removing the (2) joint connector bolts on the panel located at the back side of the utility column and hookup the electrical power source in the j-box behind the panel. See [Figure 10](#). See separate instruction sheet(s) for wiring details. Replace panel when finished. For lighting hookup remove the panel above the lower panel for access to lighting j-box(s).

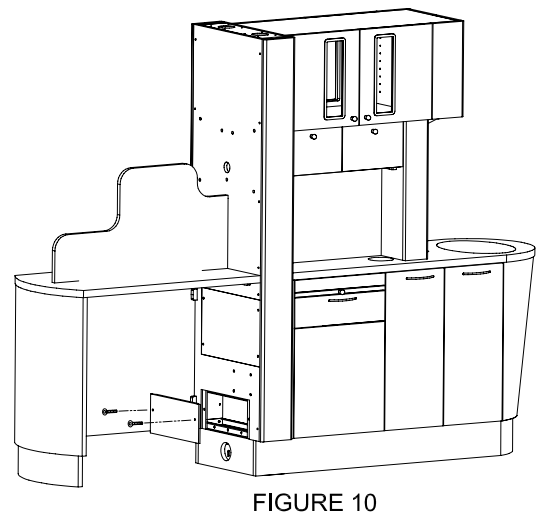

## Step 11

Hookup soap dispenser and faucet according to manufacturers installation instructions. Hookup drain according to local plumbing codes. See separate "Loop Venting Guidelines" page for further information. Installation is now complete.

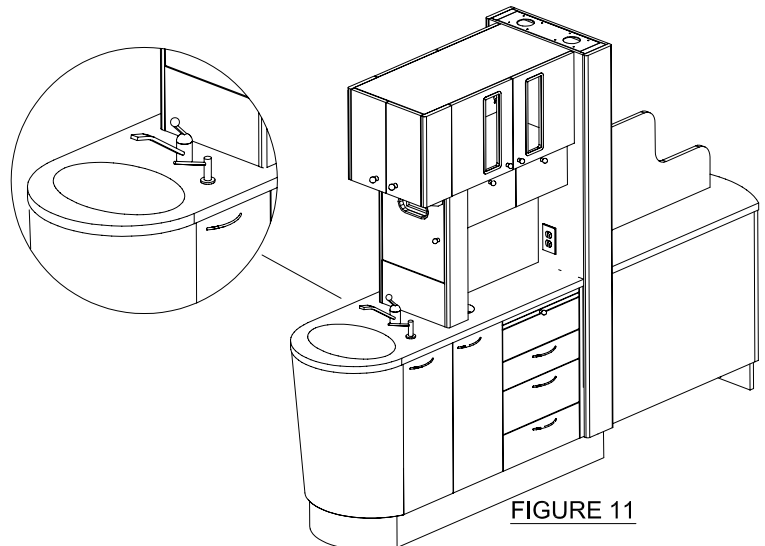

Installation Complete

# D-4R & D-4RH Assembly Instructions

## Component Identification

CABINET DRAWINGS BASED ON THE D-4R VERSION (72" HIGH)

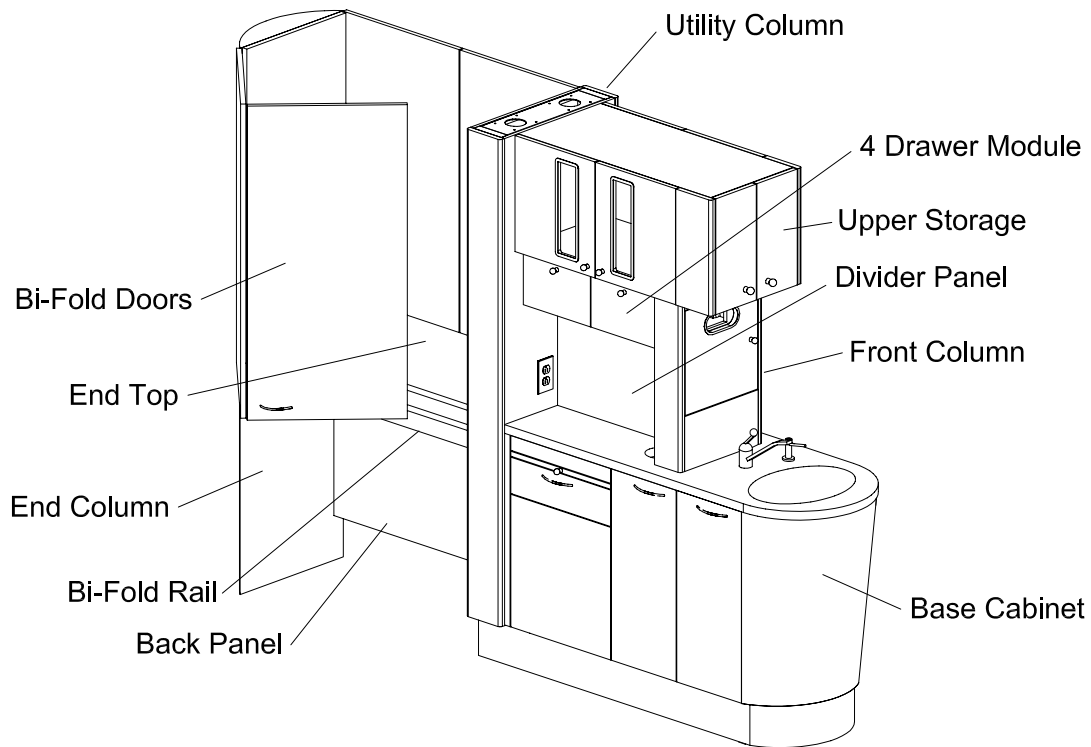

D-4R - BI-FOLD OPTION

# D-4R & D-4RH Assembly Instructions

## Step 1

Move the base cabinet into position and check the incoming power and plumbing rough-in locations for proper alignment. Remove the rectangular hole cover on the interior of the base cabinet under the sink section for access to the front floor brackets and leveling feet. Drill the holes in the floor through the floor brackets for securing the base to the floor and secure with proper fasteners. Level unit by using the leveling feet. See Figure 1.

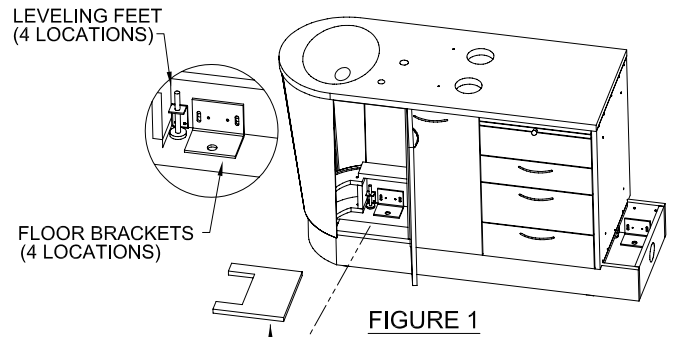

## Step 2A

Remove the drawer on the doctor's side under the bread board and the bottom drawer on the Assistant's side. Place utility column onto rear of base cabinet on top of the exposed kickplate. See Figure 2A.

In the drawer opening on the doctor's side under the bread board drive in (2) 1/4-20 x 1 1/2" RH machine screws, lock washers and washers in the provided holes. See Figure 2B.

In the bottom drawer opening on the assistants side drive (2) 1/4-20 x 1 1/2" RH machine screws with lock washers and washers in the provided holes. See Figure 2C.

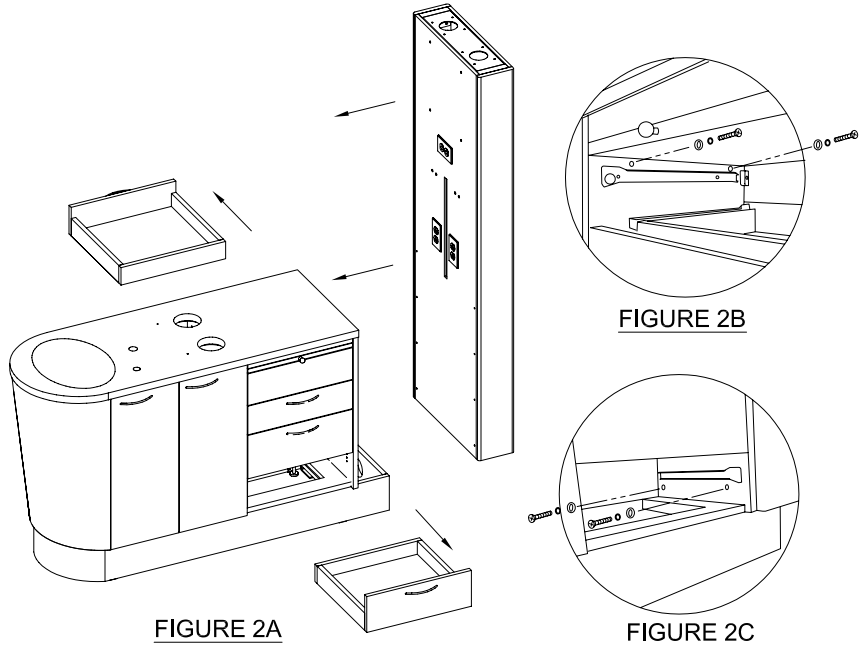

## Step 3

Place the front column and the divider panel onto the cabinet top making sure the divider panel fits in the slot on the utility column and the front column. See Figure 3A.

Open the trash drawer and from underneath the top fasten the front column to the top by using (2) 1/4-20 x 2" RH machine screws with lock washers and washers. See Figure 3B.

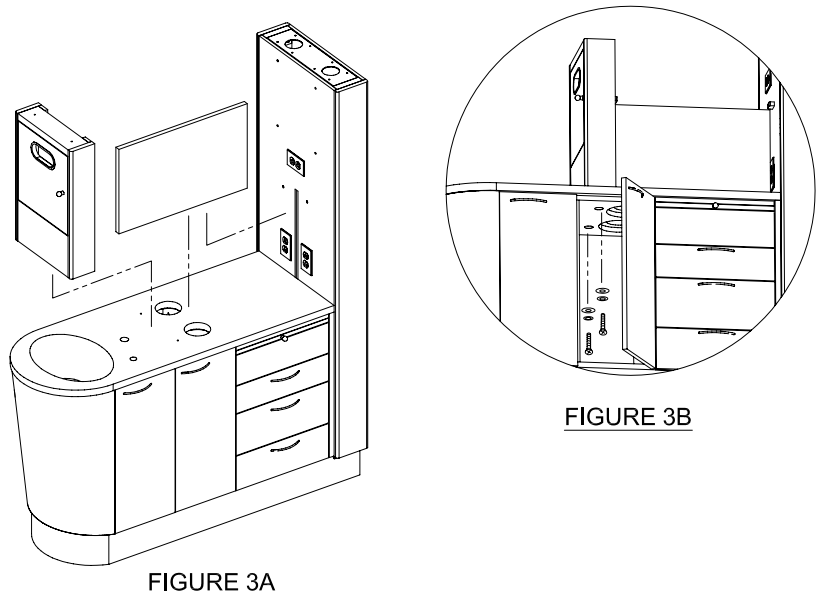

# D-4R & D-4RH Assembly Instructions

## Step 4

Drop the upper flip down door section onto the divider panel making sure the (4) Rafix studs on the utility column and front column insert in the (4) Rafix housings on the bottom of the door module then tighten each one with a screwdriver. See Figure 4A. & Figure 4B.

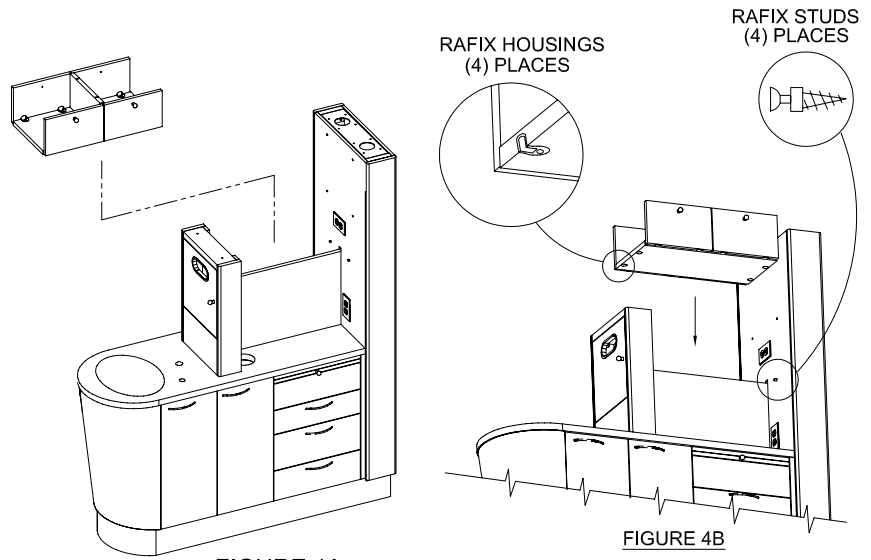

## Step 5

Make sure the (2) Rafix studs are screwed into the bottom of the upper storage. See Figure 5A.

Open the (4) flip down doors mounted to the top of the divider panel then place the upper storage onto the mid section. See Figure 5B. Make sure the (2) Rafix studs insert into the Rafix housings on the top of the flip down door center divider then tighten each one.

Join upper storage to the utility column by fastening (4) 1/4-20 x 1 1/4" joint connector bolts from inside the upper storage. See Figure 5C.

Open the door on the front column and from beneath fasten the upper storage front by using (2) #8 x 1 3/4" FH wood screws. See Figure 5D.

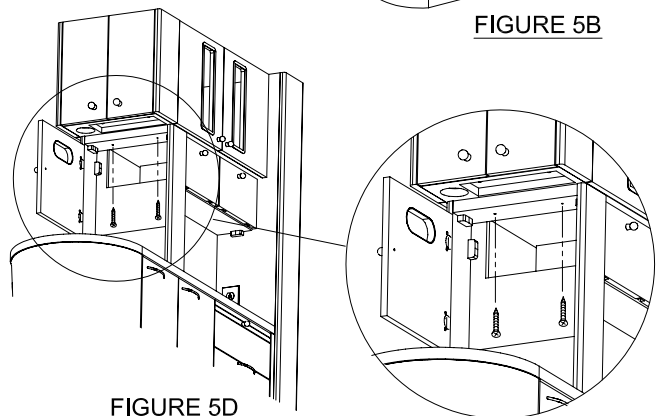
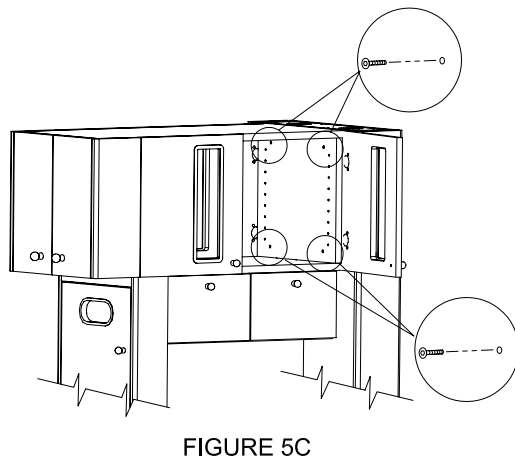
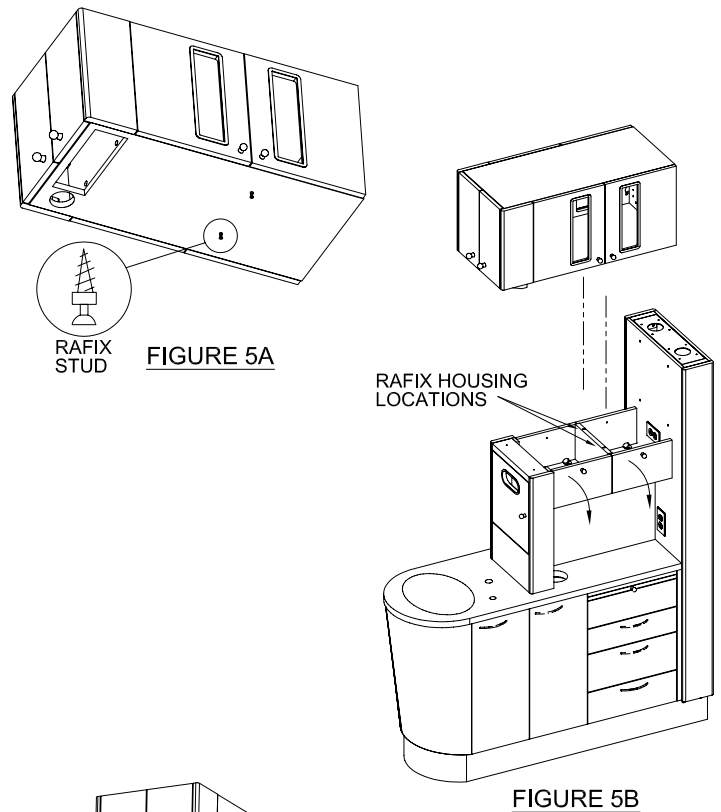

FIGURE 5C

FIGURE 5D

# D-4R & D-4RH Assembly Instructions

## Step 6

Place bi-fold back panel up against the utility column making sure to connect the (2) KD connectors. Engage the KD connectors by turning the screw clockwise about 1/2 turn. See Figure 6. Have an assistant hold the unattached end steady so it does not fall over.

Connect the end column to the (2) KD connectors on the back panel. Engage the KD connectors by turning the screw clockwise about 1/2 turn. See Figure 6.

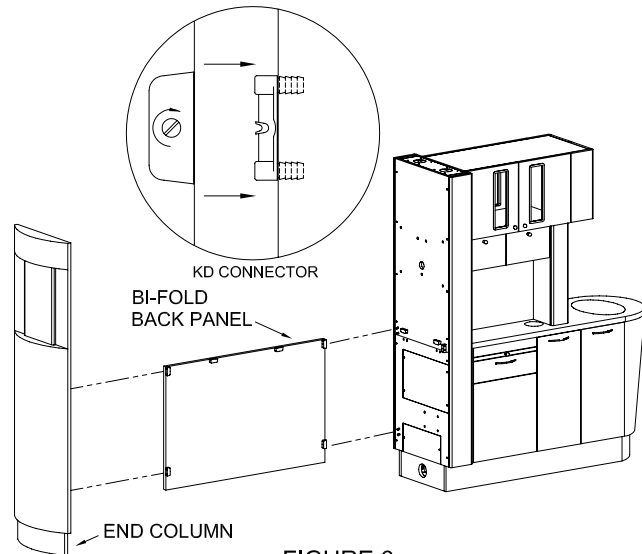

FIGURE 6

## Step 7

Connect the bi-fold rail to the KD connectors on the utility column and the end column. Engage the KD connectors by turning the screw clockwise about 1/2 turn. See Figure 7.

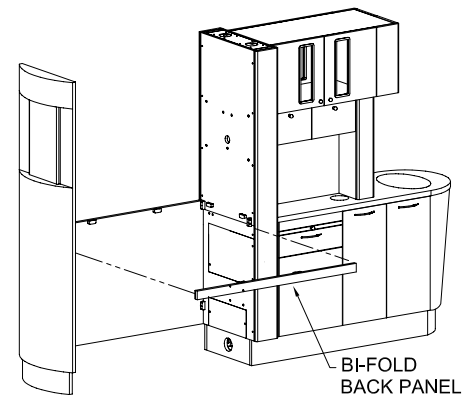

FIGURE 7

## Step 8

Make sure the (2) roller trucks are positioned inside the slide channels on both sides of the end top. The set-screw should be opposite of the magnet so the magnet can make contact with the flate side of the roller truck. See Figure 8A.

Position the end top so that the magnet block stop end will connect with the end column. See Figure 8B.

Set the end top onto the rail and back panel making sure the (8) KD connectors properly join. Engage the KD connectors by turning the screw clockwise about 1/2 turn. See Figure 8C. **Adjust leveling feet on end column to level the bi-fold section.**

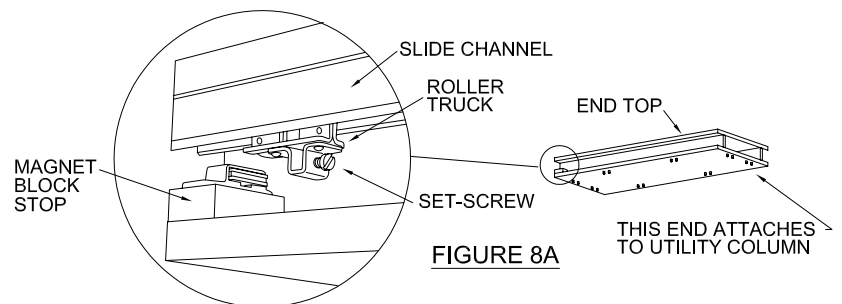

FIGURE 8A

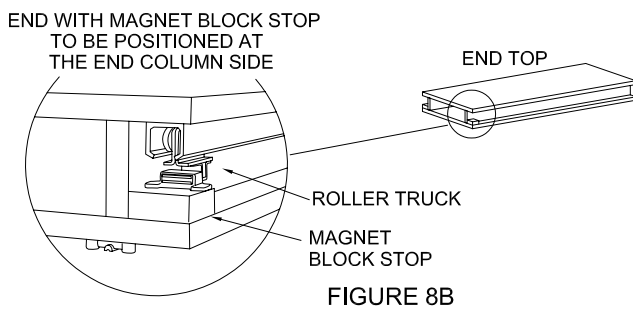

FIGURE 8B

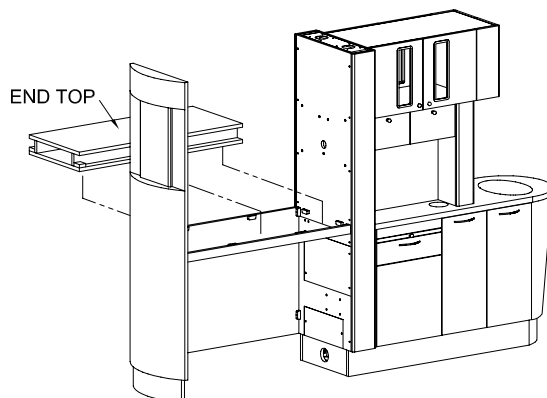

FIGURE 8C

# D-4R & D-4RH Assembly Instructions

## Step 9

Make sure the set-screw on all hinge plates (on end column) are only 1/2 way screwed in. See Figure 9A.

Have an assistant hold one set of doors up then snap the top hinge into the hinge plate then tighten the set-screw. See Figure 9B. Do this for each hinge. Repeat for both sides.

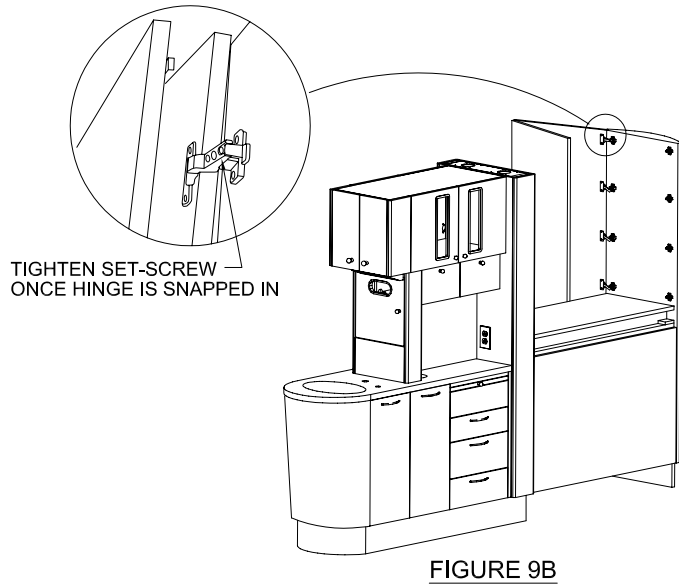
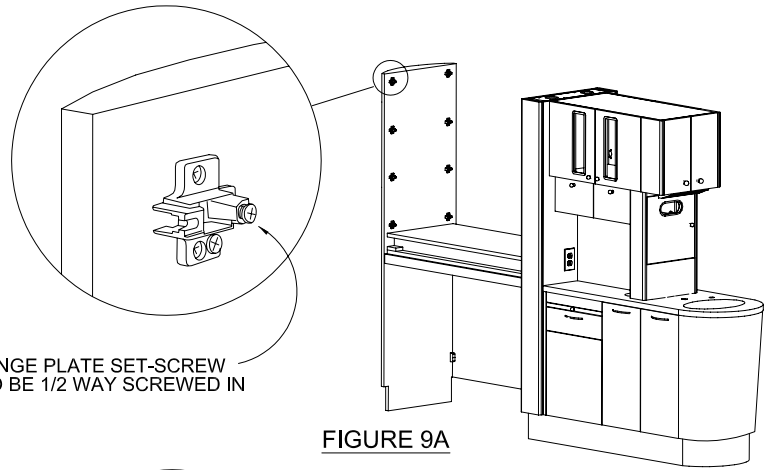

## Step 10

At the bottom of the door insert the hinge stem into the roller and tighten the set-screw. See Figure 10. Repeat for both sides.

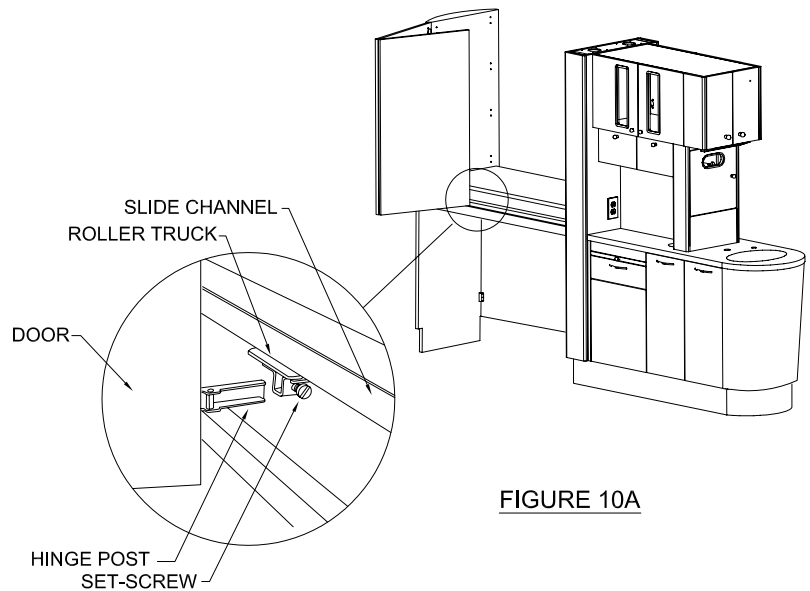

# D-4R & D-4RH Assembly Instructions

## Step 11

Screw in the door guide on the top side of the bi-fold doors with (2) #6 - 5/8" P.H. wood screws. See Figure 11. Repeat for other side.

Screw in the door bracket on the upper corner of the utility column with (2) #6 - 5/8" P.H. wood screws. See Figure 11. Repeat for other side.

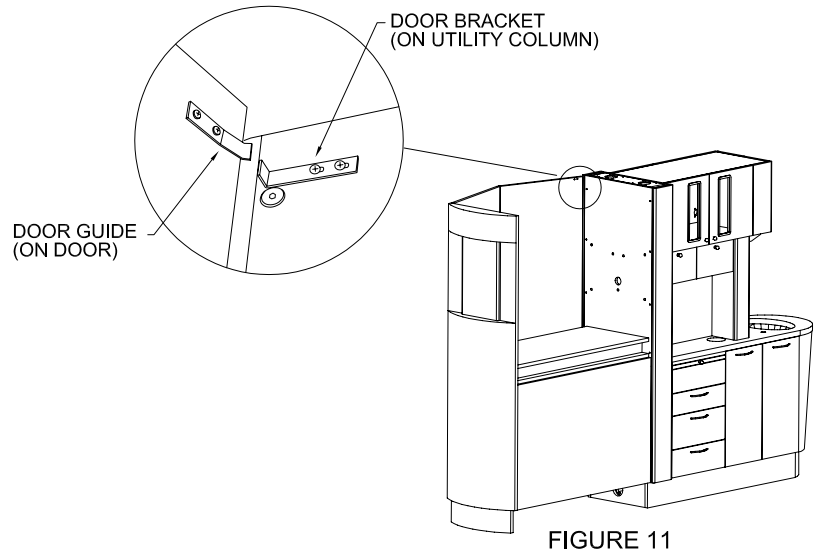

## Step 12

Open the door on the front column and insert the cup dispenser (cylinder shape) into the hole (with the outward dimples at the top). See Figure 12.

With the door still open in the front column insert (4) glass support pins into desired holes and place (1) 5 1/8" x 15 1/16" glass shelf on support pins. See Figure 12.

Open doors on the upper storage and insert (4) glass support pins into the desired holes for the 14 3/4" x 26 5/8" glass shelf then place the glass shelf onto the support pins. See Figure 12.

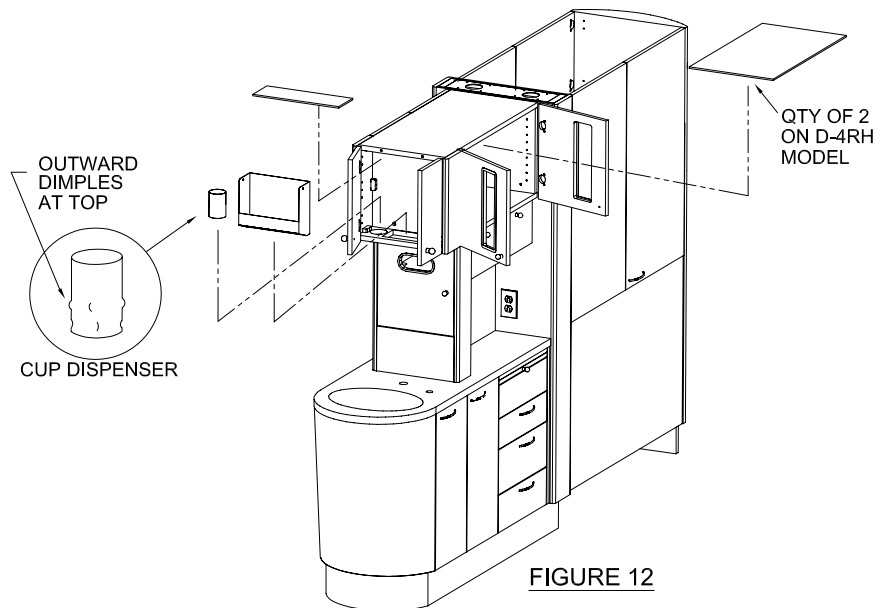

# D-4R & D-4RH Assembly Instructions

## Step 13

Remove the bottom access panel by removing the (2) joint connector bolts on the panel located at the back side of the utility column and hookup the electrical power source in the j-box behind the panel. See [Figure 13](#). See separate instruction sheet(s) for wiring details. Replace panel when finished. For lighting hookup remove the panel above the lower panel for access to lighting j-box(s).

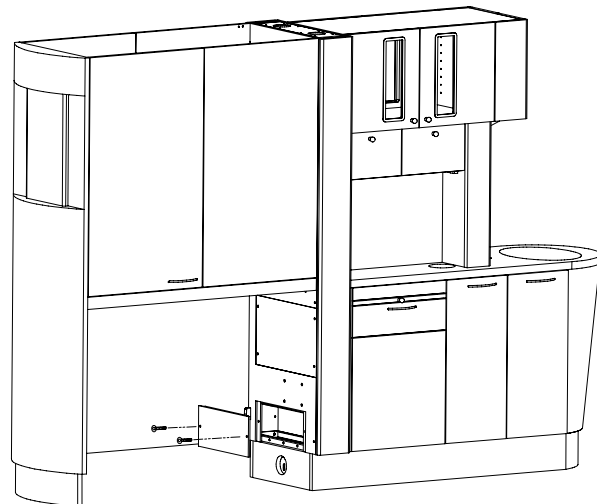

FIGURE 13

## Step 14

Hookup soap dispenser and faucet according to manufacturers installation instructions. Hookup drain according to local plumbing codes. See separate "Loop Venting Guidelines" page for further information. Installation is now complete.

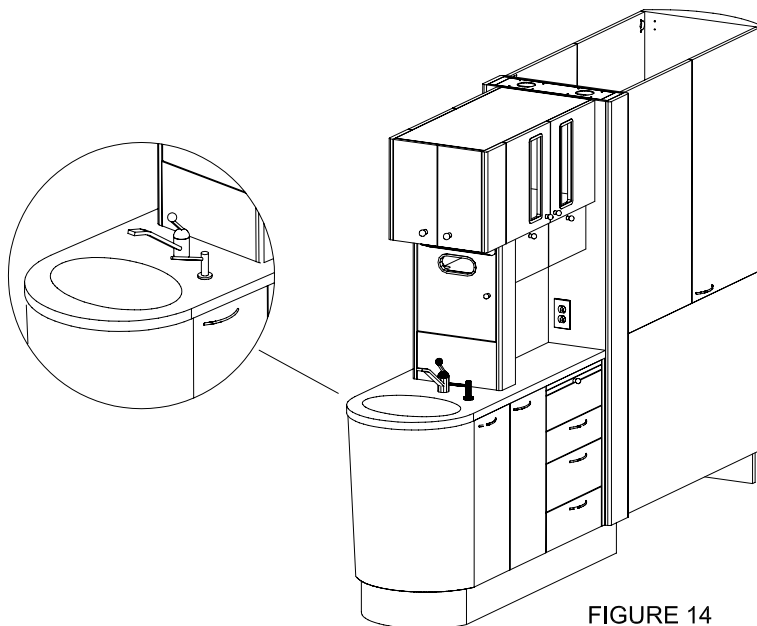

FIGURE 14

Installation Complete

# D-4R & D-4RH 91-170 Drawer Option Installation

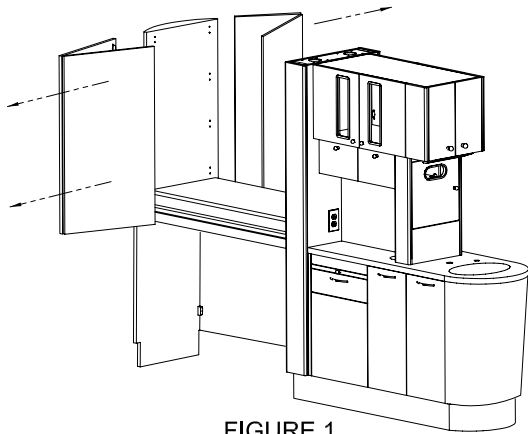

FIGURE 1

## Step 1

Remove Bi-Fold Doors. See Figure 1. Refer to D-4R & D-4RH Assembly Instructions (Bi-Fold Option) - Page 5 - Reverse steps 9 & 10.

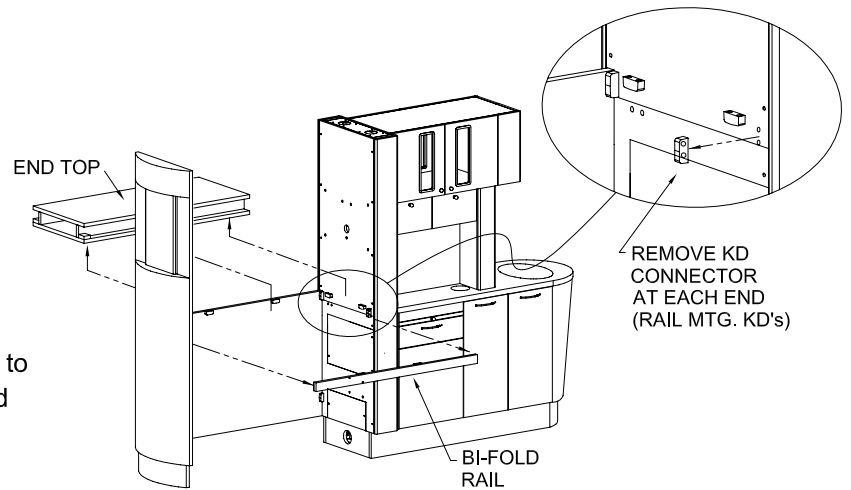

FIGURE 2

## Step 2

Remove End Top & Rail See Figure 2. Refer to D-4R & D-4RH Assembly Instructions (Bi-Fold Option) - Page 4 - Reverse steps 7 & 8.

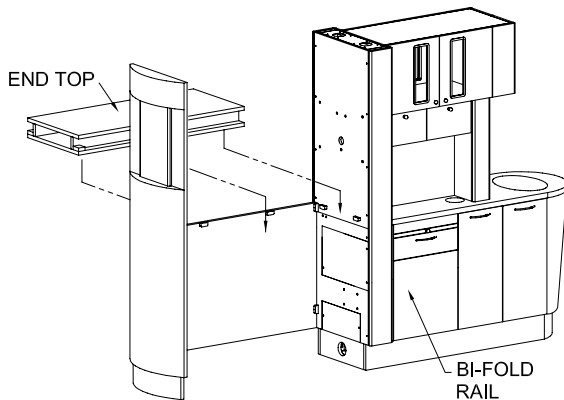

FIGURE 3

## Step 3

Install End Top See Figure 3. Refer to D-4R & D-4RH Assembly Instructions (Bi-Fold Option) - Page 4 - Follow step 8 (without Rail).

## Step 4

Reinstall Bi-Fold Doors. See Figure 4. Refer to D-4R & D-4RH Assembly Instructions (Bi-Fold Option) - Page 5 - Follow steps 9 & 10.

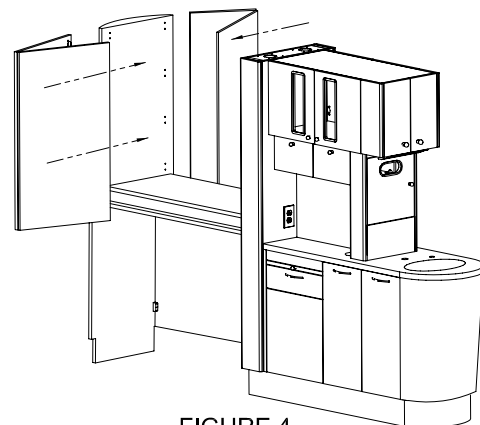
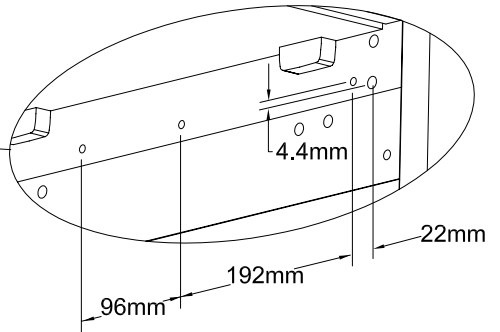
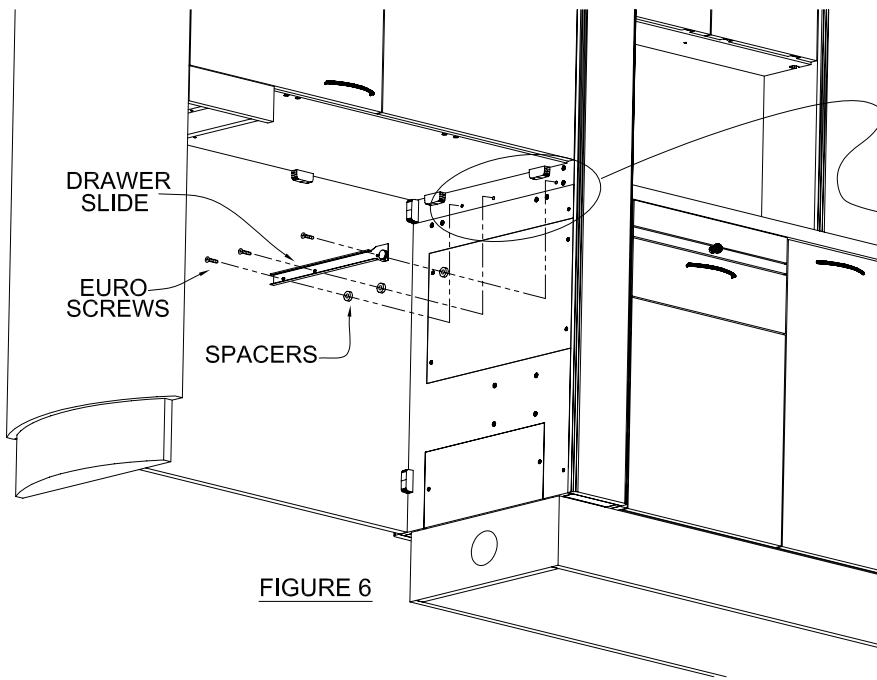
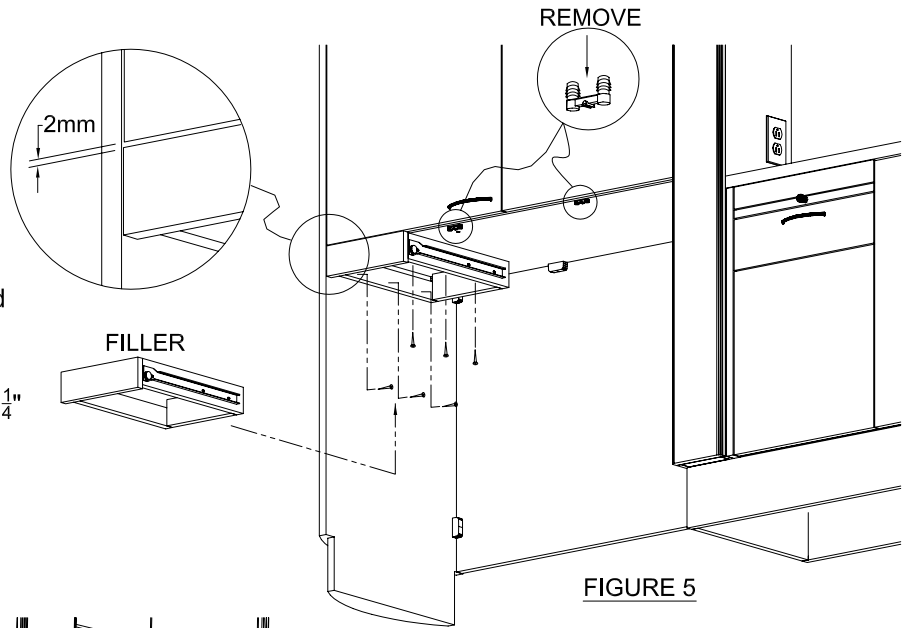

FIGURE 4

# D-4R & D-4RH 91-170 Drawer Option Installation

## Step 5

Remove KD pins from the bottom of the bi-fold top. Mount filler to left End Column. Make sure face of filler is flush with Bi-Fold door face and there is approx. a 2mm gap between the top of the filler face with the bottom of the Bi-Fold door. Use (6) #8 x 1- $\frac{1}{4}$ " wood screws. See Figure 5.



## Step 6

Mark and drill (3) 5mm ( $\frac{3}{16}$ " ) holes at locations shown. See Figure 6.

Install drawer slide w/plastic spacers between the slide and the cabinet. Use (3) 18mm Euro Screws (#P40811).

## Step 7

Insert drawer onto drawer slides. See Figure 7.

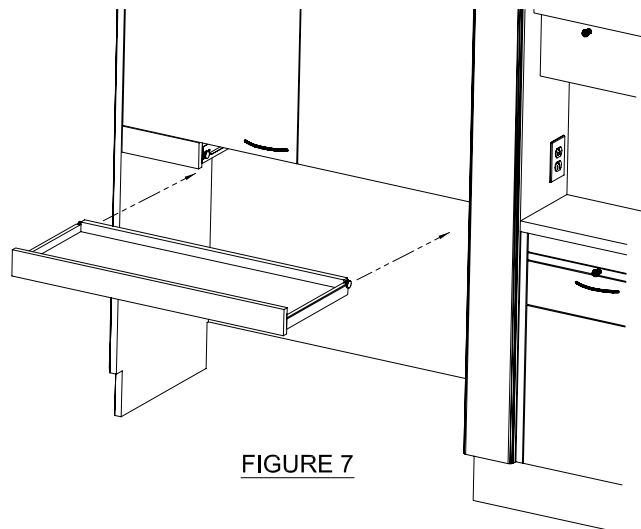

## Adjustment Instructions for Concealed Hinges and Drawers

### 3-Dimension Adjustment for Snap-On Hinge

Note: Remove Cover Cap

Allows for three-way adjustments in the hinge arm.  
The side adjustment is a micro adjustment. The depth and height adjustment is held by a grid system.

Use #2 POZIdrive screwdriver to adjust screws.

- 1 – Side adjustment
- 2 – Depth adjustment
- 3 – Height adjustment

### Release Latch

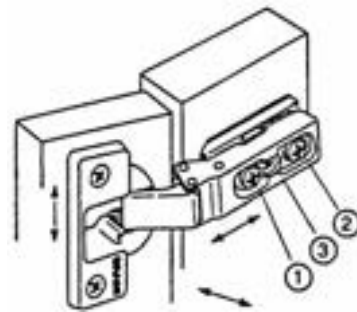

### Adjustment for Drawer

- 1 – Height adjustment: Loosen screws **B** slightly. Adjust screw **A** (adjustment +/- 2mm). Tighten screws **B**.
- 2 - Side adjustment: Loosen screws **B** slightly. Adjust front to required position (adjustment range +/- 1.5mm). Tighten screws **B**.

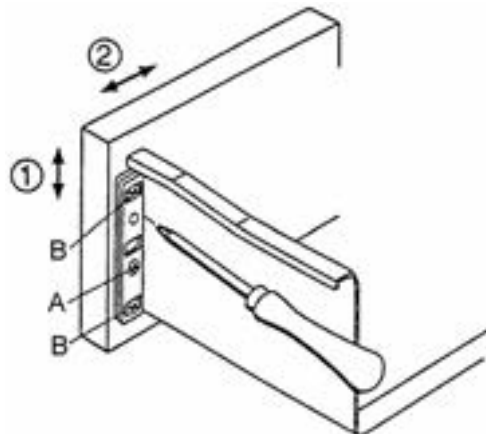

## **X-CALIBUR™ CABINETRY SYSTEM**

### **LAMINATE SURFACE CLEANING INSTRUCTIONS**

The disinfectant solution should be applied in accordance with the instructions provided by the manufacturer. The following solution is recommended for laminate surfaces, it may also be used on metal and glass surfaces.

Product	Manufacturer
Birex ®	Biotrol International
Kodak Clinasept	Kodak
Foaming Disinfectant	Catalogue No. 829-5230

Koken not responsible for any changes made by the manufacturer in the chemical composition of the cleaning solution listed above, which may effect the finishing after application.

### **SOLID SURFACE VENEER**

#### **CLEANING, CARE AND MAINTENANCE**

In most cases, caring for your solid surface veneer countertop or surface is as simple as wiping the surface with a damp cloth. If a stain develops, wipe it away with soap and water. Or if you prefer, wipe it clean with Windex® - **not 409® or Fantastic®**. **NOTE: The cleaning chemicals used to clean Laminate material are not to be used on solid surface veneer material, such chemicals may damage the solid surface veneer material.**

If a stain doesn't respond to soap and water, for a matte finish, apply an abrasive cleanser and buff with a Scotch-Brite® pad using a circular motion. The same technique can be used for cigarette burns.

For minor cuts and scratches, simply sand lightly with medium (180 grit) sandpaper, then follow with a fine (220 grit) sandpaper. Finally touch up the finish by buffing with a Scotch-Brite® pad.

#### **PRECAUTIONS:**

Do not expose the surface to harsh chemicals, such as chloroform, eugenol, methyl ethyl ketone, paint remover, turpentine, nail polish remover or stove and drain cleansers. If these chemicals come in contact with the surface, immediately wash them off with water, using appropriate safety measures to avoid injury.

In case of staining or spotting, sand lightly with fine sandpaper, then buff in a circular motion with a Scotch-Brite® pad. Hot pans or heat-producing appliances can mar your solid surface veneer surface when placed directly on the countertop. Always use a trivet with legs. Care should be taken in order to keep the surface looking as good as new.

**NOTE:** The warranty shall not apply to defects or damages arising from any of the following:

- Accidents abuse or misuse of chloroform, eugenol and solvents such as acetone/M.E.K. These chemicals can possibly damage and discolor solid surface veneer materials if in contact over time.
- Exposure to extreme temperatures.
- Improper maintenance.

Koken not responsible for any improper care of solid surface veneer material and that any warranty will be void.

### **CAMBRIA QUARTZ SURFACES**

#### **CLEANING, CARE AND MAINTENANCE**

Cambria is care free therefore no sealing, buffing, polishing or reconditioning required. Using soap and water is sufficient to clean the Cambria surface.

## D-4R & D-4RH ELECTRICAL HOOKUP

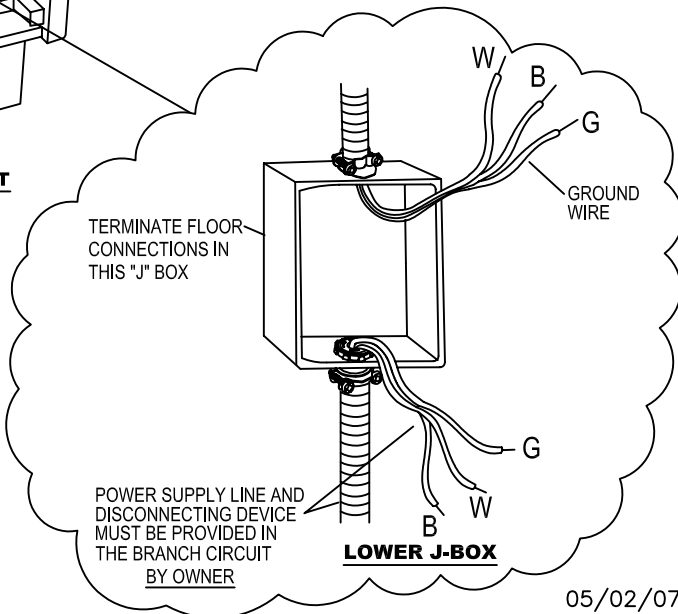
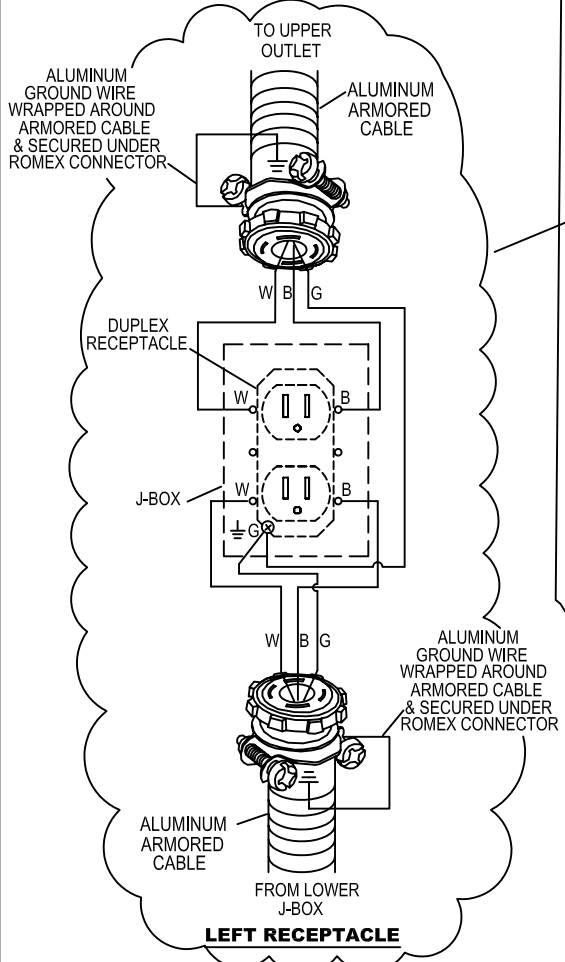
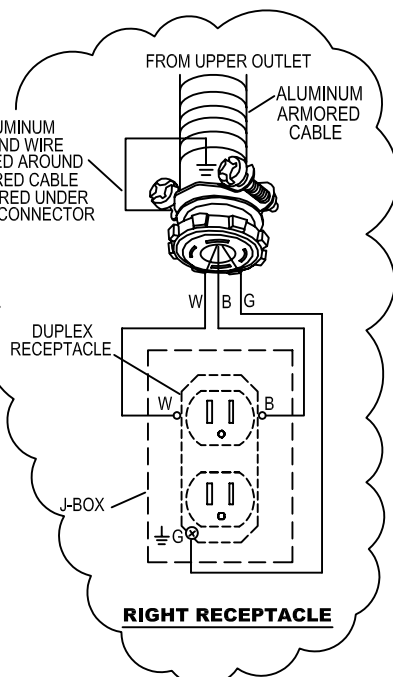
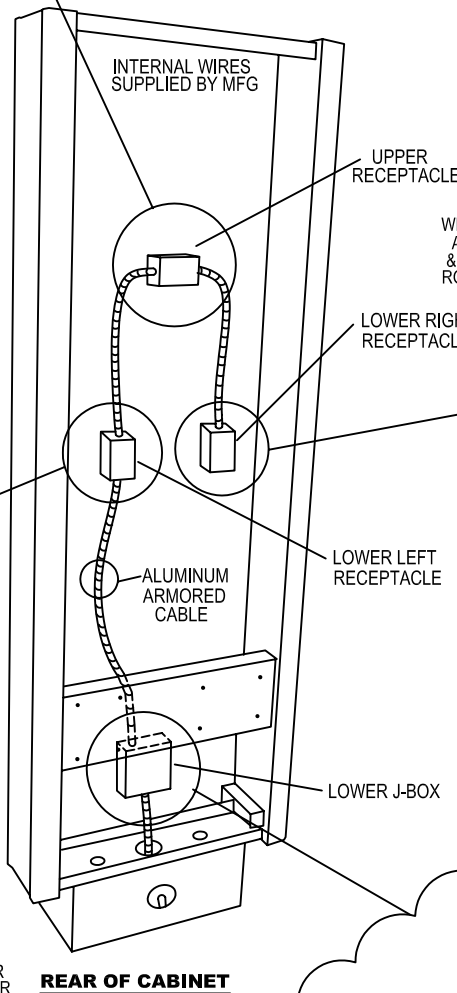
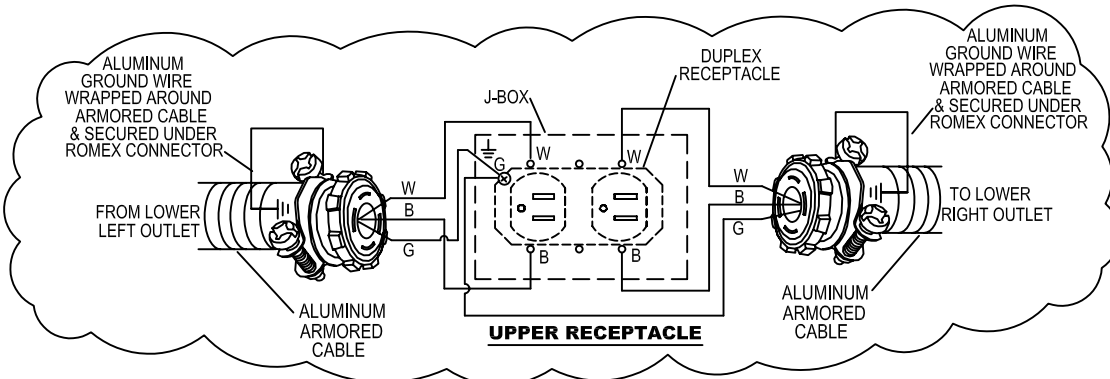

## D-4R & D-4RH X-Calibur Electrical Instructions

**IMPORTANT NOTE:** Approved electrical components and designs are used in the X-Calibur cabinet; however, the procedures described herein must be performed by a licensed electrician using approved methods and materials according to the local code governing the installation site.

### General Electrical Notes

- Each cabinet should be wired to a SEPARATE 15 Amp circuit.
- Unless otherwise specified, ALL WIRING supplied by the contractor must be APPROVED 12 Ga. AWG.
- You have the option of wiring the fluorescent light in this cabinet to an adjacent cabinet which contains a control (clock/timer) panel. All lights in a treatment area can thus be activated from a single washable switch. See option wiring diagram.

The remote switching system can accommodate the FLUORESCENT FIXTURE ONLY. DO NOT add any other loads to the remotely switched circuit. Approved 16 Ga. AWG wiring may be used for the lamp feed ONLY if it is acceptable for this use under local code.

## D-4R and D-4RH Electrical Parts List

1. Junction box w/cover, galvanized steel. Overall dimensions, 4" long, 2 1/8" wide, 1 1/2" deep, .07" thick and 4"long, 4 1/4" wide, 1 1/2" deep .07" thick.. Secured to laminated particle board by screws. U.L. listed or equal.
2. Internal cords are 14/3 & 12/ 3 AWG, TYPE SO, SOO, SJ, SJT, SJO, or SJTO insulated, rated 300 VAC, 60°C, U.L. listed or equal.
3. Conduit connector, 3/8" insulated. U.L. listed or equal.
4. Insulated spade tongue, for #12 Ga. AWG. U.L. listed or equal.
5. Wire connectors, (wire nut), screw on type. U.L. listed.
6. Flexible conduit, flexible steel conduit, 1/2". U.L. recognized or equal.
7. Receptacle, duplex 2-pole 3 wire grounding hospital grade, rated 125 VAC, 15 AMPS. U.L. listed or equal.
8. Wall plate, duplex, U.L. listed.
9. Option: Fluorescent lamp assembly. See ETL report no. 3044675.001, Page 18.

# WIRING SCHEMATIC FOR #507-T CLESTA LIGHT

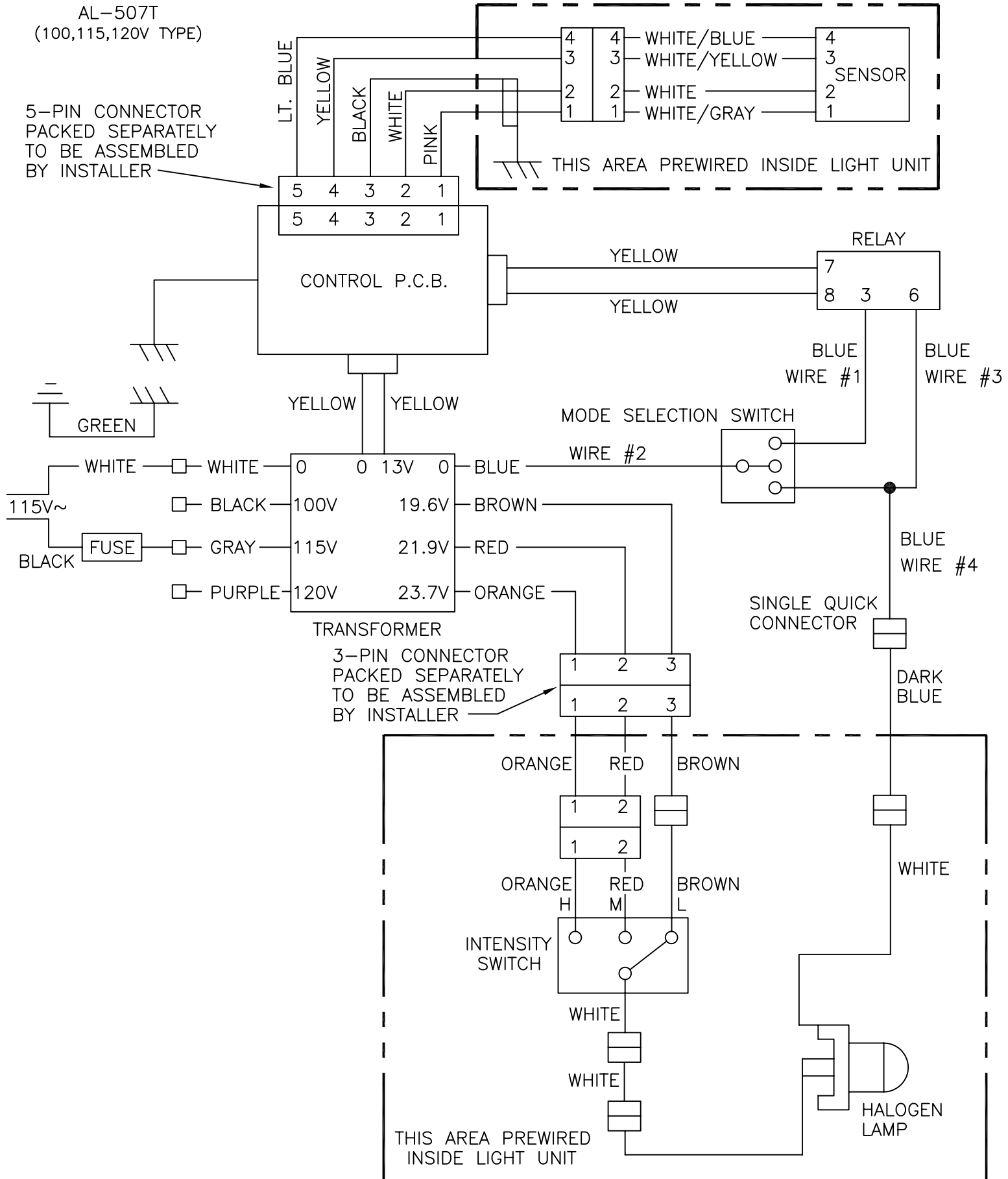

# D-4R & D-4RH SPLIT ENTRY CONSOLE

## WIRING DIAGRAM FOR #507-T CLESTA LIGHT

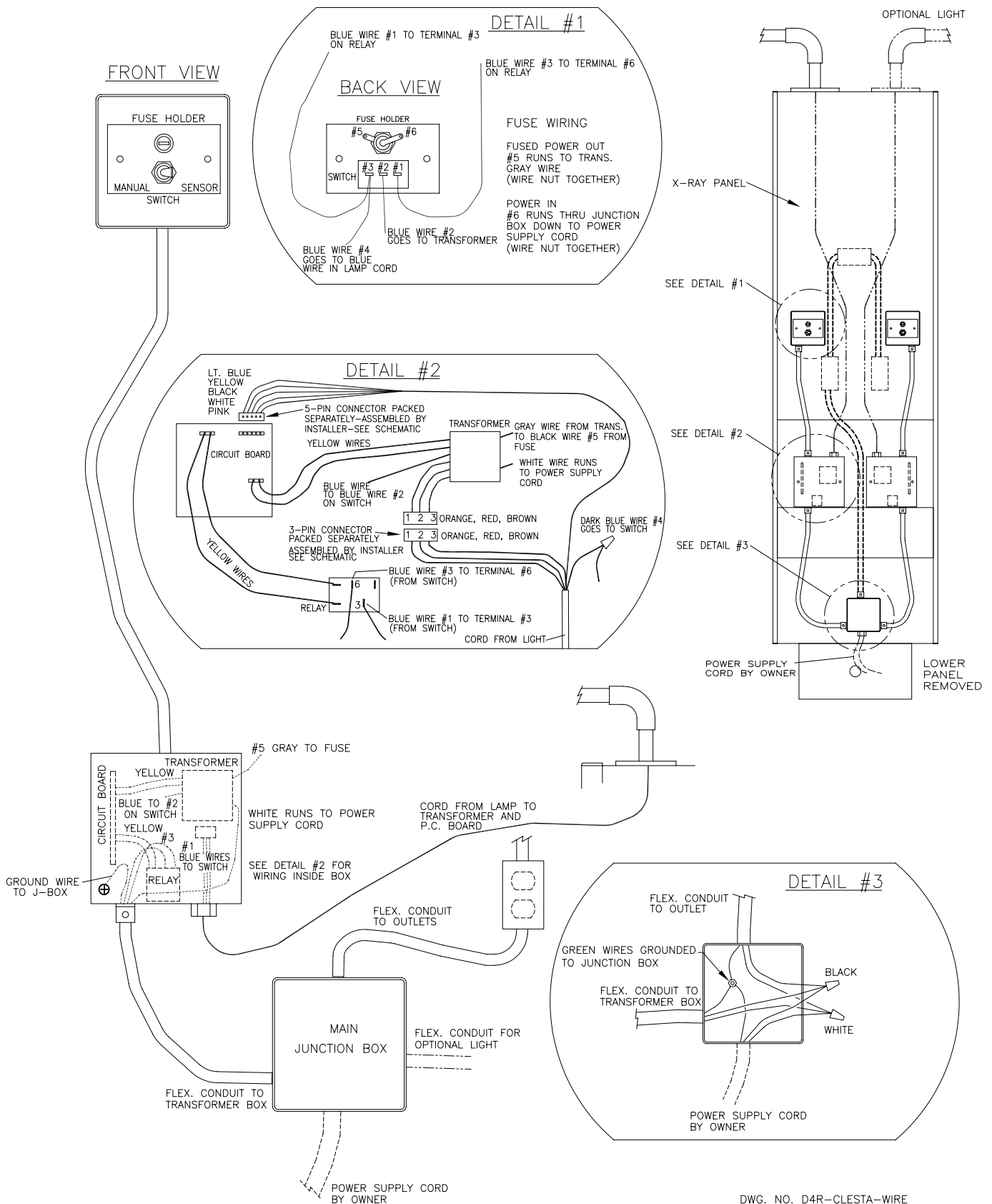

# D-4R / D-4RH AND E-4/E-4G SPLIT ENTRY CONSOLE

## WIRING DIAGRAM FOR #907 BEL-HALO LIGHT

### BACK VIEW

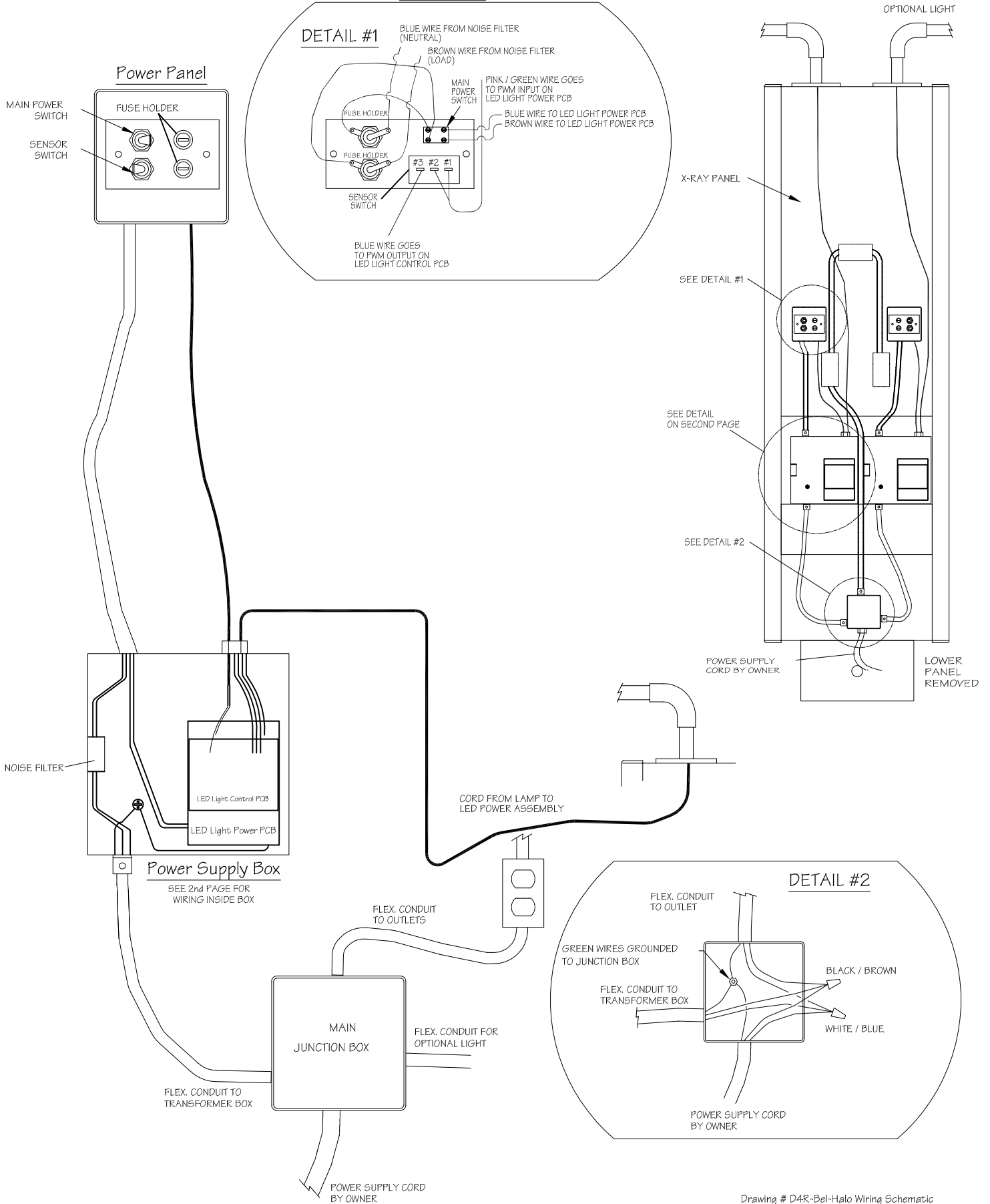

# BEL-HALO WIRING SCHEMATIC

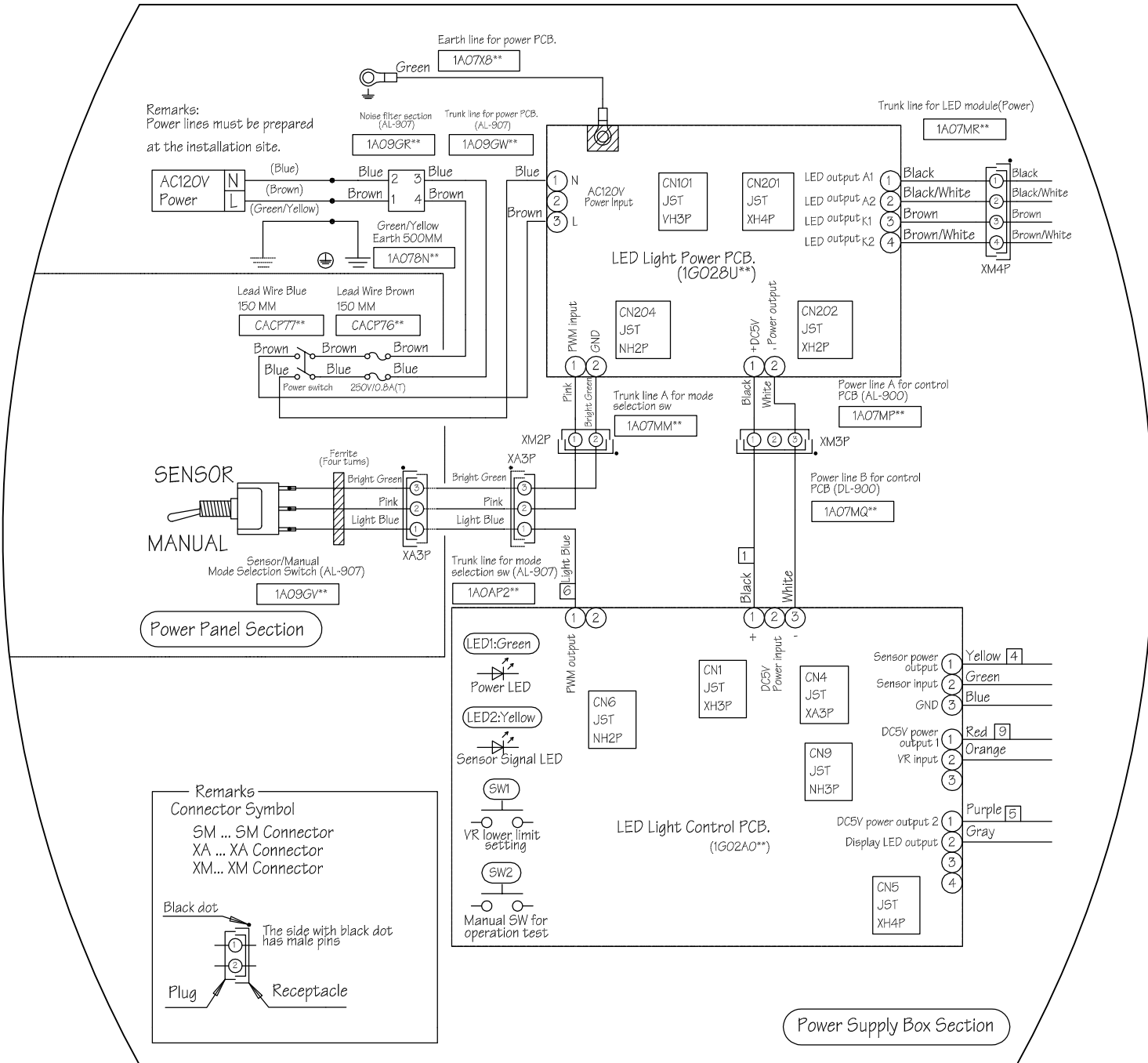

INTERLOCKING WIRING (LOW VOLTAGE)  
FOR BI-FOLD DOOR

NOTICE:

1. Please check X-ray specifications on how to modify the exposure switch wiring as shown below.
2. See your local department of Social and Health Services for X-ray radiation protection.

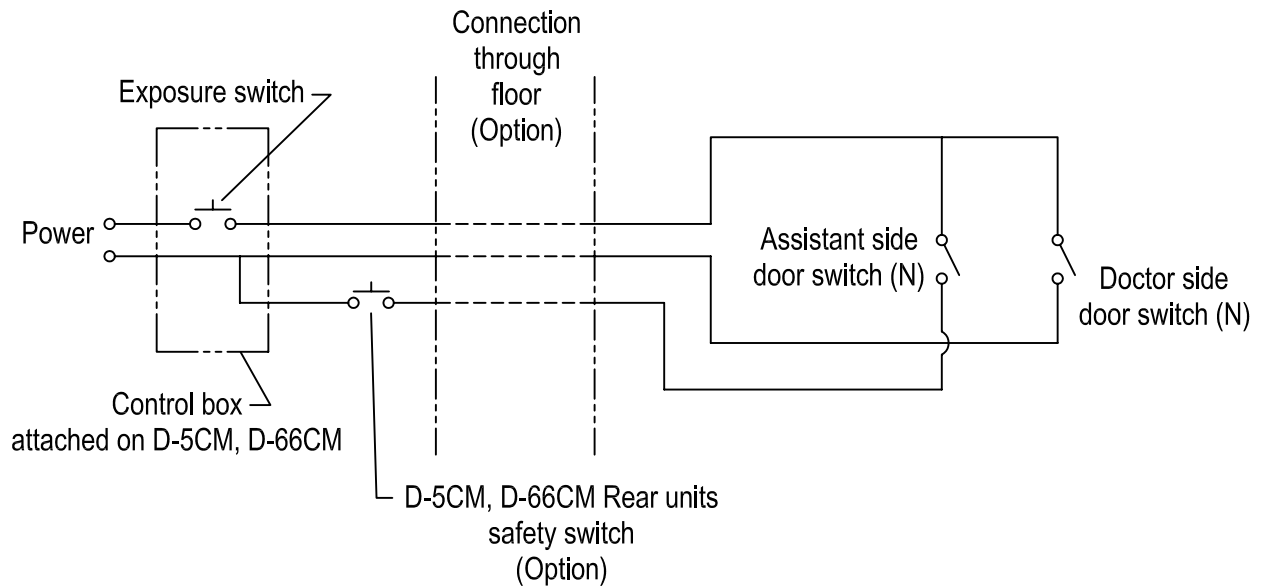

ALTERNATE PLAN

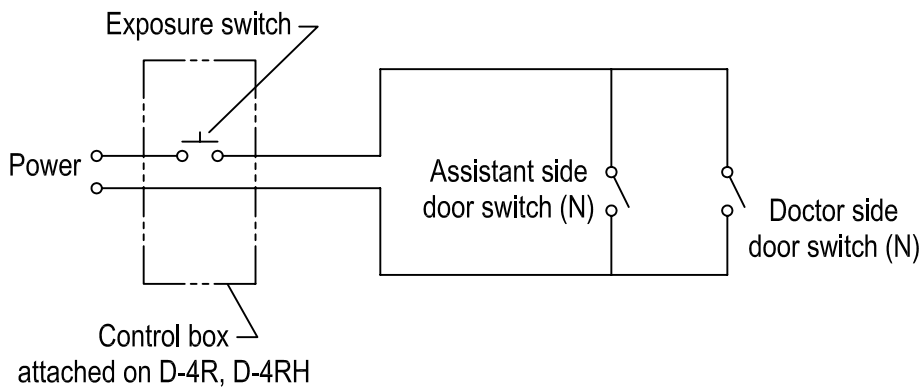



## D-4R X-CALIBUR CABINETS LOOP VENTING GUIDELINES

NOTE: As an alternative to vertical stack venting, loop venting within the cabinet is preferred in many installations. Local codes vary, and a locally licensed plumber must perform the installation. The guidelines below will aid in planning the installation.

1. The floor templates for all sink-equipped cabinets show the recommended locations for loop vents and drains. Clearance is provided for 2" pipe, however in many cases 1-1/2" or 1-1/4" may be accepted.
2. The designs are symmetrical so that either leg can be the drain and the other the vent, as determined by pipe requirements under the floor.
3. The illustrations below show a typical assembly utilizing standard plumbing components. The neoprene couplings with stainless steel clamps permit the loop to be constructed before installation of the cabinetry, and temporarily removed to permit installation of the cabinetry.

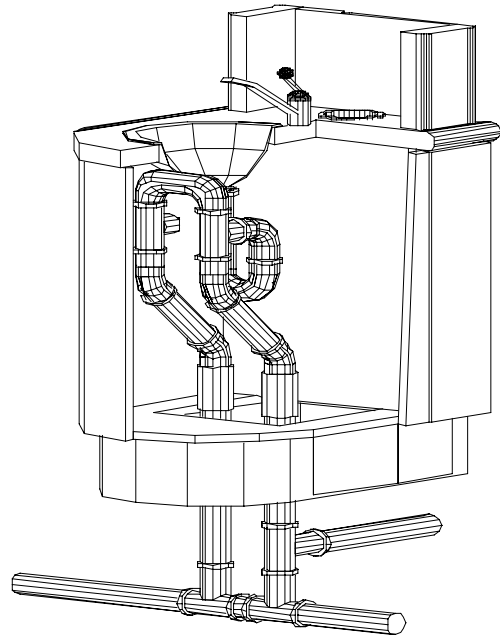
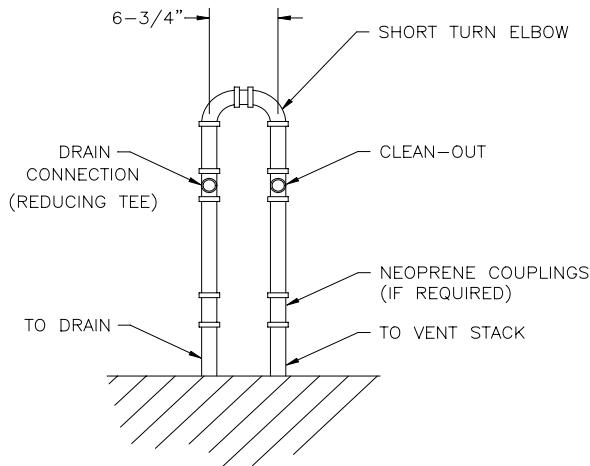
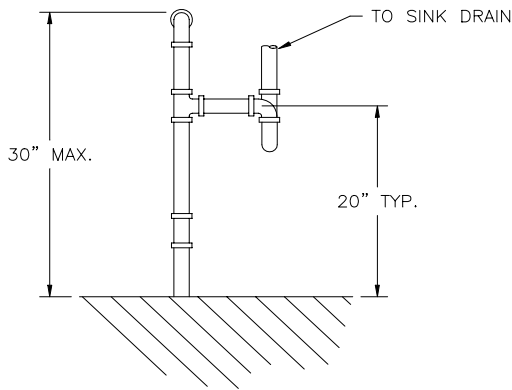

A-4R X-Calibur Cabinet  
Installation Instructions for Optional Bi-Fold Doors

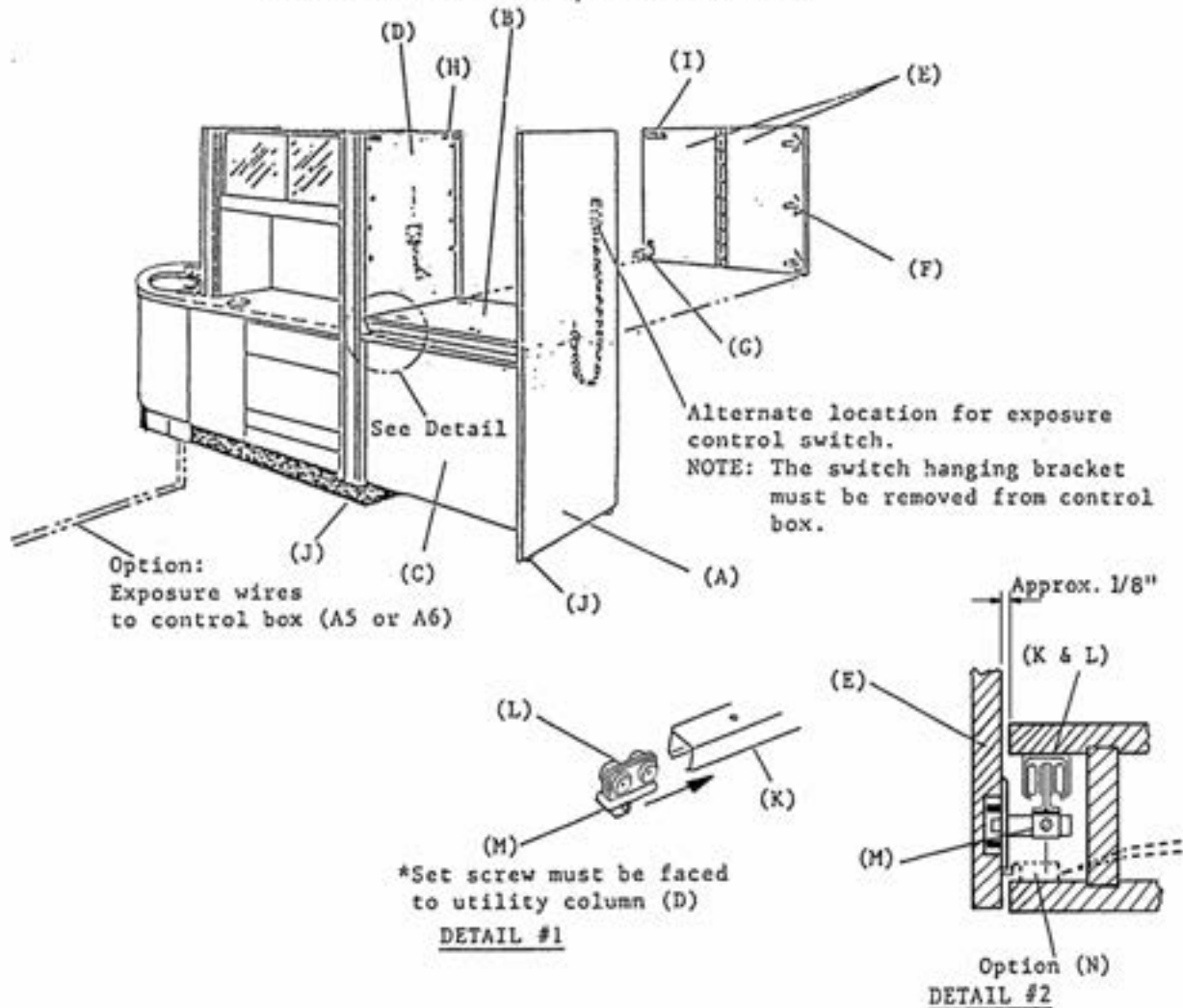

1. Attach the end leg (A), countertop (B), and panel (C) to the utility column (D) with the 8 K.D. connectors provided.  
Note: When you are inserting the roller (L) into the track (K), make sure that the set screw (M) is facing the utility column. See detail #1.
2. Make sure the cabinet is level to the floor. If not adjust with the adjustable glides (J).
3. Attach the door (E) and hinge (F) to the end leg (A), then insert the end of hinge (G) into roller (L), then secure with set screw (M). See detail #2.
4. Adjust the latch bracket (H) to close the door properly.
5. Option: Interlocking system for x-ray exposure.
  - (1) Adjust the microswitch (N) to work properly.
  - (2) Remove the upper countertop (B) and install the electric wires. (See other detail)

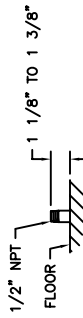
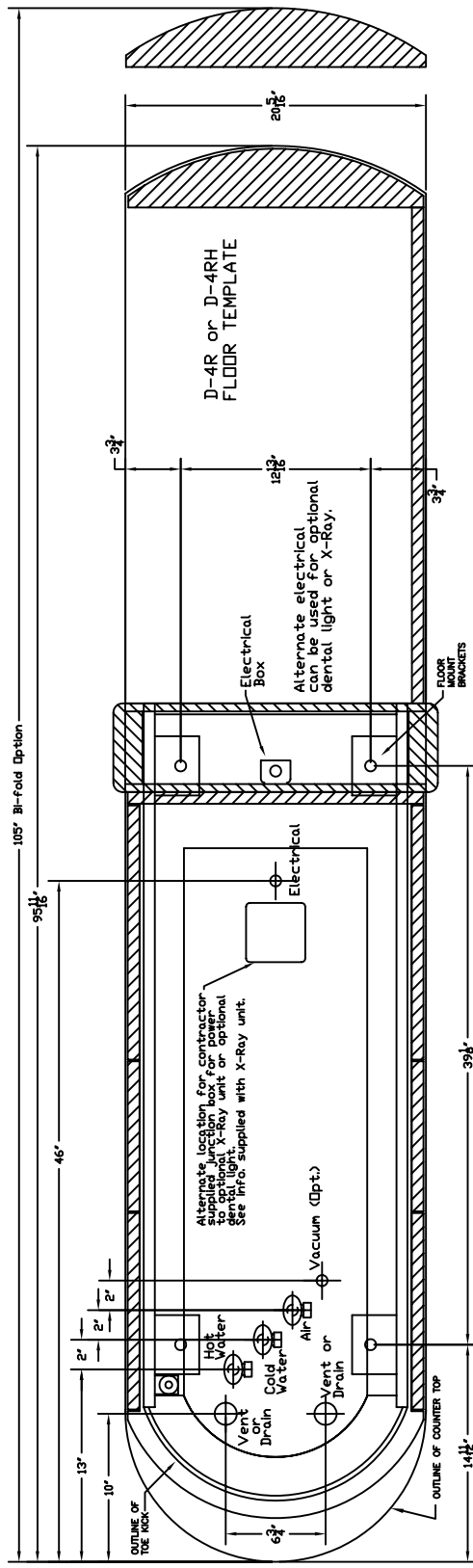

DETAIL OF AIR, WATER, AND VACUUM STUBS (STOP VALVES SUPPLIED WITH CABINET)

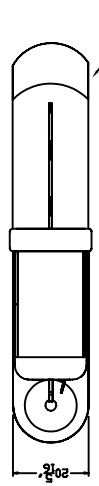
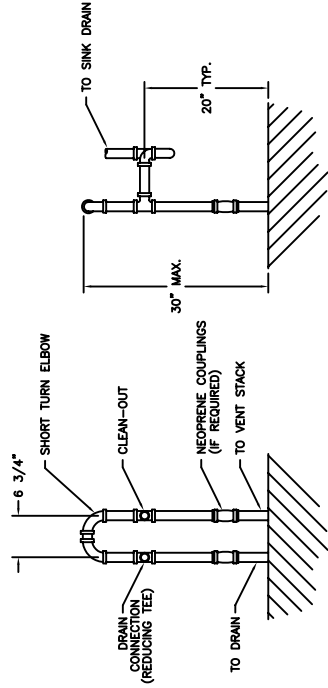

TOP VIEW

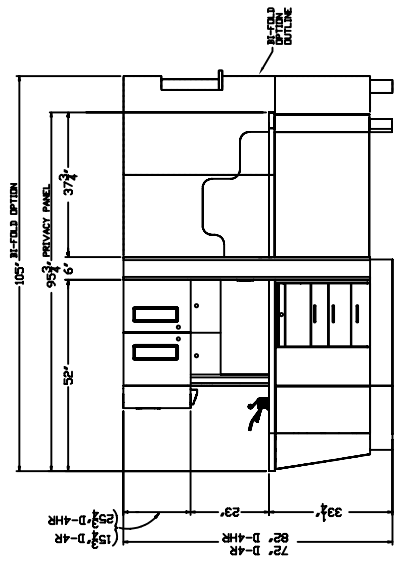

FRONT VIEW

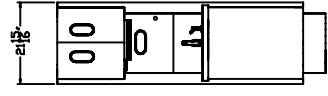

LEFT SIDE VIEW

NOTE: PLAN AND ELEVATION VIEWS ARE FOR REFERENCE ONLY. SEE INSTALLATION MANUAL FOR DETAILED INFORMATION.

KOKEN MANUFACTURING ASSUMES NO RESPONSIBILITY FOR MEASUREMENTS MADE BY THE CONTRACTOR. LOCATION OF ELECTRICAL SOURCES OR CORRECT MEASUREMENTS ON THIS DRAWING ARE THE RESPONSIBILITY OF THE ARCHITECT OR LOCAL REGULATIONS. THESE ITEMS, AS WELL AS LOCAL CODE REGULATIONS, SHOULD BE CHECKED WITH THE ARCHITECT OR PROPER CONTRACTOR BEFORE WORK IS STARTED.

PLUMBING NOTES  
 1-1/2" DRAIN SHOWN. SIZE MAY VARY ACCORDING TO LOCAL CODE.  
 IT IS THE RESPONSIBILITY OF THE INSTALLER TO VERIFY ALL MEASUREMENTS AND LOCAL CODE WITH REGARD TO MATERIALS, VENTING, ETC.

REV.	DATE	DESCRIPTION	BY
		KOKEN MANUFACTURING CO., INC. ST. LOUIS, MISSOURI	
MATERIAL		TITLE	
FINISH		DRAWN BY	
		SCALE	1=1
		DATE	7/11/2003
		DRAWING NO.	P11345

D-4R & D-4RH  
 FLOOR TEMPLATE