

D-Series Dental Cabinetry System

Installation Manual

Model: D-66CM



 **Belmont**

1631 Dr. Martin Luther King Drive
St. Louis, MO 63106
(314) 231-7383 1-800-325-7373
Fax (314) 621-2296
www.belmontequip.com

D-66CM Assembly Instructions

Component Identification

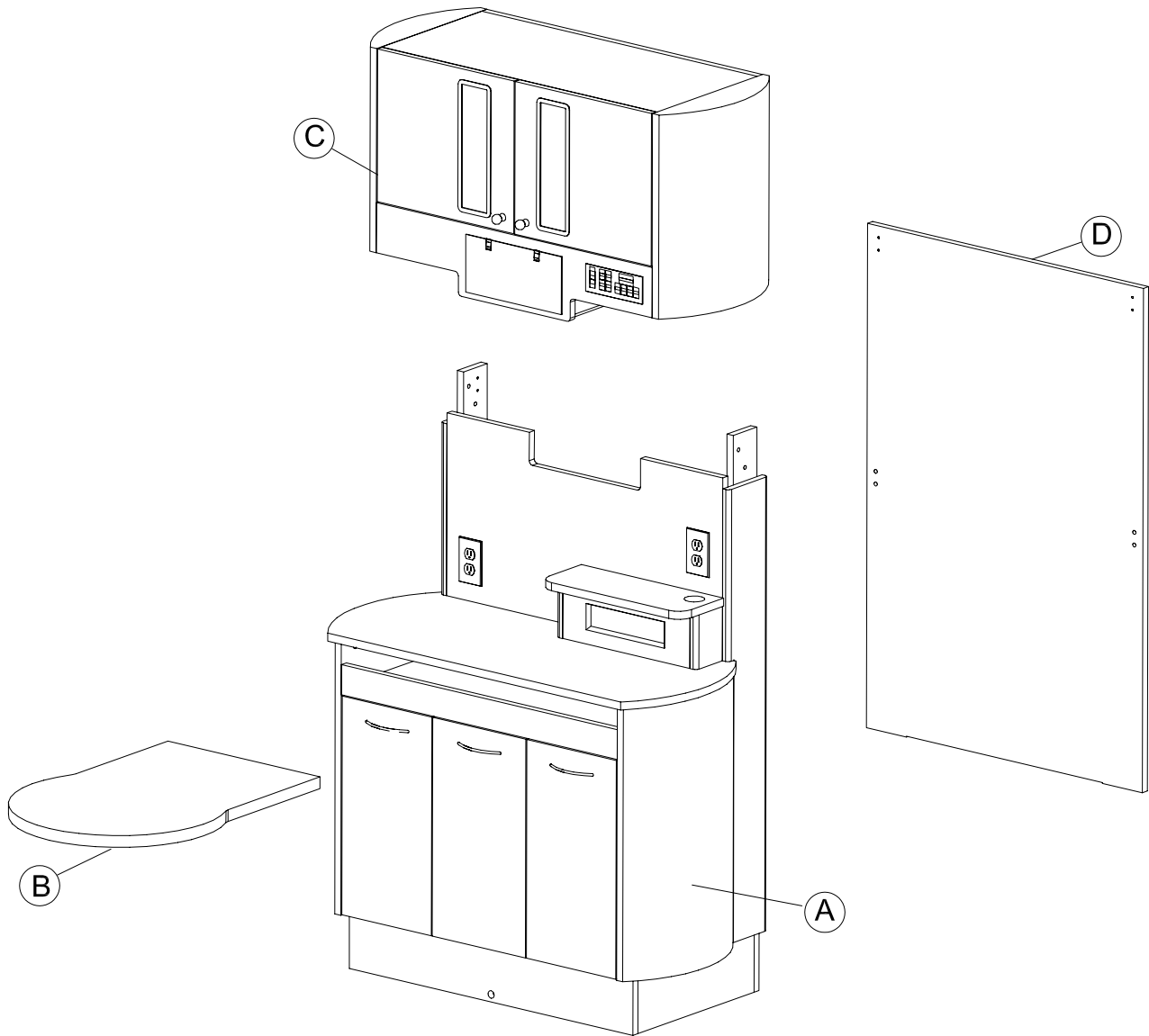

Component Identification

- (A) Cabinet Base
- (B) Sliding Top
- (C) Upper Storage
- (D) Back Panel

Note:

Back panel (item D) is attached to base cabinet (item A) during shipping. It must be removed for cabinet assembly.

D-66CM Assembly Instructions

Step 1

Check the incoming power location to see if it conforms to the specification on the floor template drawing. If a dental delivery system is to be installed on this cabinet, confirm that the appropriate air, water and vacuum plumbing stubs are in place.

Step 2

Open the doors and remove the removable hole covers (A1) (quantity may vary). See Figure 2.

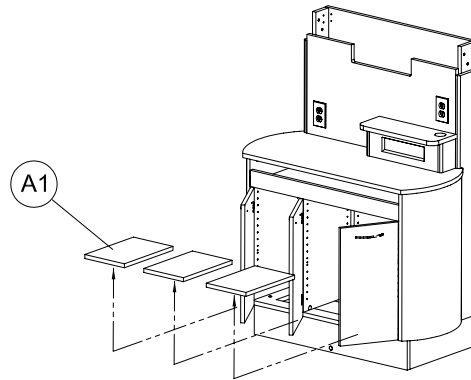

FIGURE 2

Step 3

Remove the back panel (D) from the cabinet base (A) by releasing the KD connectors connecting the back panel. Access the KD's from inside the lower cabinet at the left/right upper interior corners by opening the left/right doors. If unit is equipped with drawers remove them to access the KD's.

See Figure 3A Note that there are 2 KD connectors with the 2nd one being on the right side.

Release the KD connectors by turning the screw counter clockwise about 1/2 turn. See Figure 3B Do this to both KD's.

To remove the back panel push back on the top of the back panel until the Keku latches at the upper corners release. See Figure 3C Once unlatched you may pick up the back panel and remove.

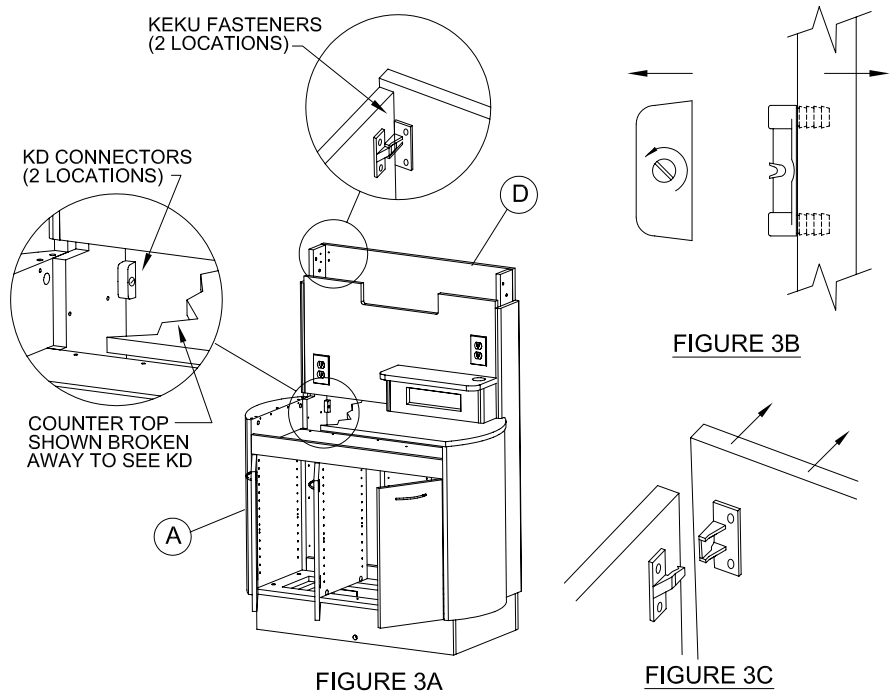

Step 4

Before moving cabinet base make sure the leveling feet are not extended. Screw in to minimum height if they are not. See Figure 4

Move the cabinet base over the electric &/or plumbing stubs. Using the leveling feet level the unit. Secure to floor using the floor brackets. See Figure 4

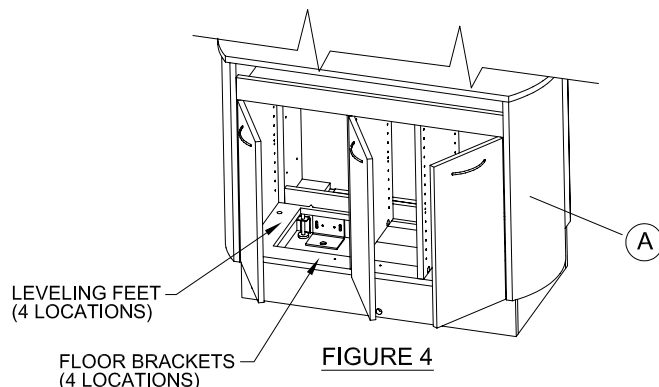
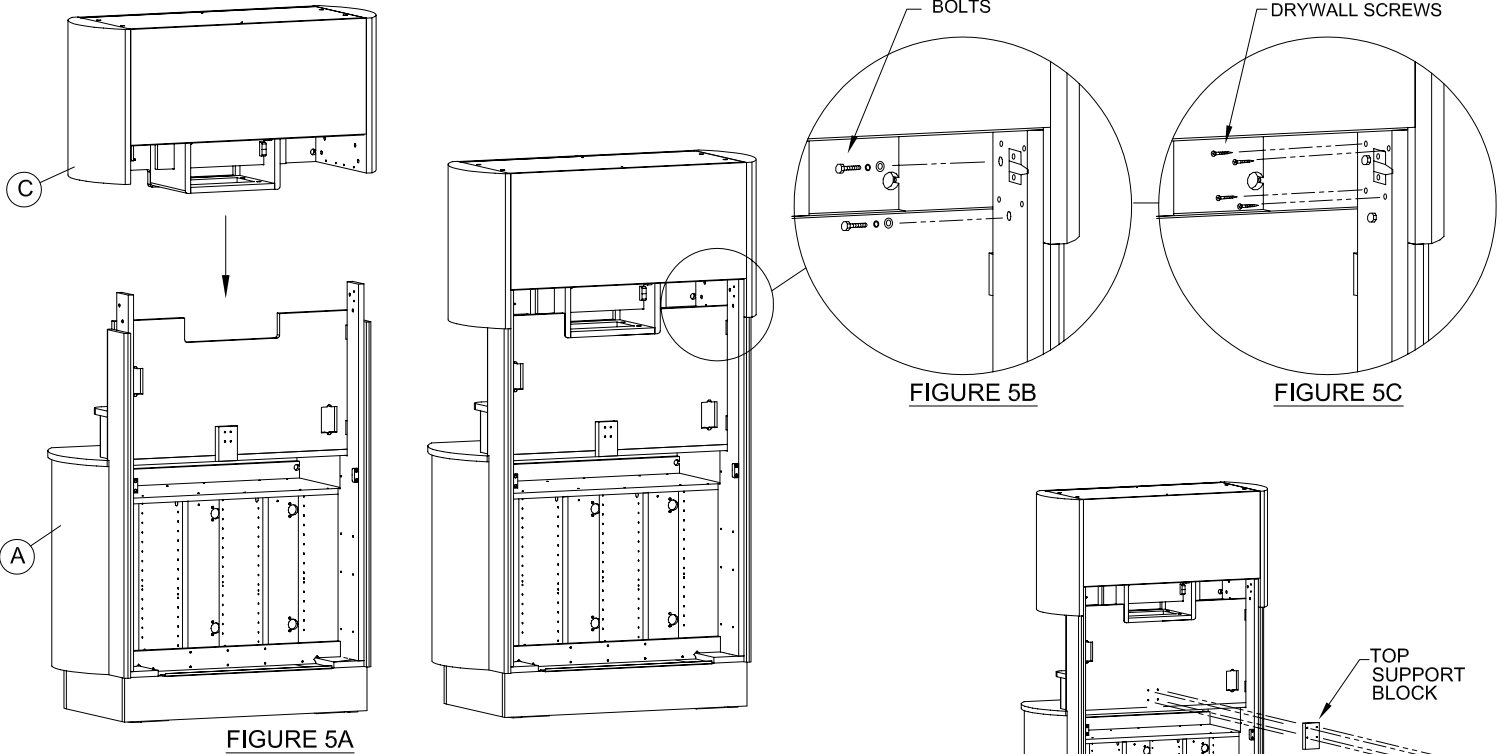

FIGURE 4

D-66CM Assembly Instructions

Step 5

Place upper storage (C) on top of cabinet base (A). See Figure 5A. Secure with (4) 5/16-20 x 2" bolts, each with a 5/16" flat washer and 5/16" lock washer. (2 bolts on each side). See Figure 5B. Using (4) #6 x 1 1/4" drywall screws, drive them into the (4) holes around the bolts just fastened. See Figure 5C. Repeat for the opposite side.



Step 6

Make electrical connections per the D-66CM Electrical Instructions.

Step 7

Remove the top support block at the rear of the unit by removing wood screws. See Figure 7A. Insert sliding top from the rear with the slides extended. See Figure 7B. Have an assistant hold the sliding top in place and screw the (6) #10 x 3/4" pan head wood screws (1/4-20 x 1/2" round head screws if cambria top) through the slides into the sliding top. See Figure 7C. Replace the top support block removed in Figure 7A.

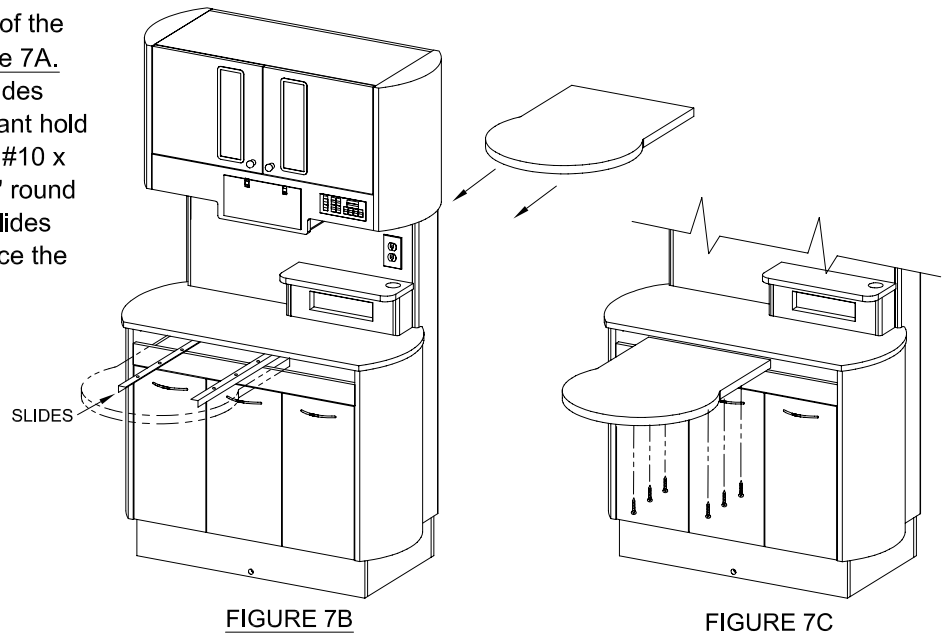

D-66CM Assembly Instructions

Step 8

Mount the left-right rear delivery unit underneath the sliding countertop (B) using (4) #10-32 x 3/4" allen head screws (requires 5/32" allen wrench). See Figure 8

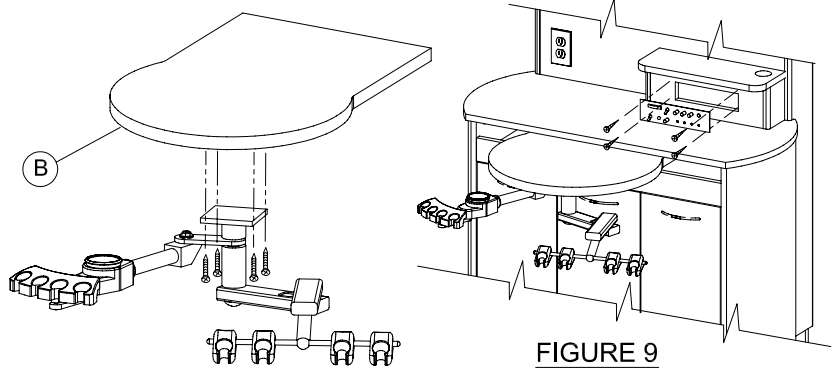

FIGURE 8
HOSES NOT SHOWN

FIGURE 9

Step 9

Install the control panel with (4) #6 x 3/4" white painted screws (supplied by manufacturer) to upper front panel and attach vacuum, air and water connections to building plumbing according to the unit manufacturers directions. See Figure 9

Step 10

Replace the back panel (D) to the cabinet base (A) by seating the back panel into the steel angle channel at the bottom of the rear opening. See Figure 10A. Tilt the top of the rear panel into position until the Keku fasteners snap together. See Figure 10B.

Engage 2 KD connectors along the vertical edges of the back panel by accessing the connectors from inside the front of the lower cabinet. See Figure 10C. Engage 2 KD connectors at the top edge of the back panel by accessing the connectors from the light panel openings under the upper storage. See Figure 10D.

Engage the KD connectors by turning the screw clockwise about 1/2 turn. See Figure 10E

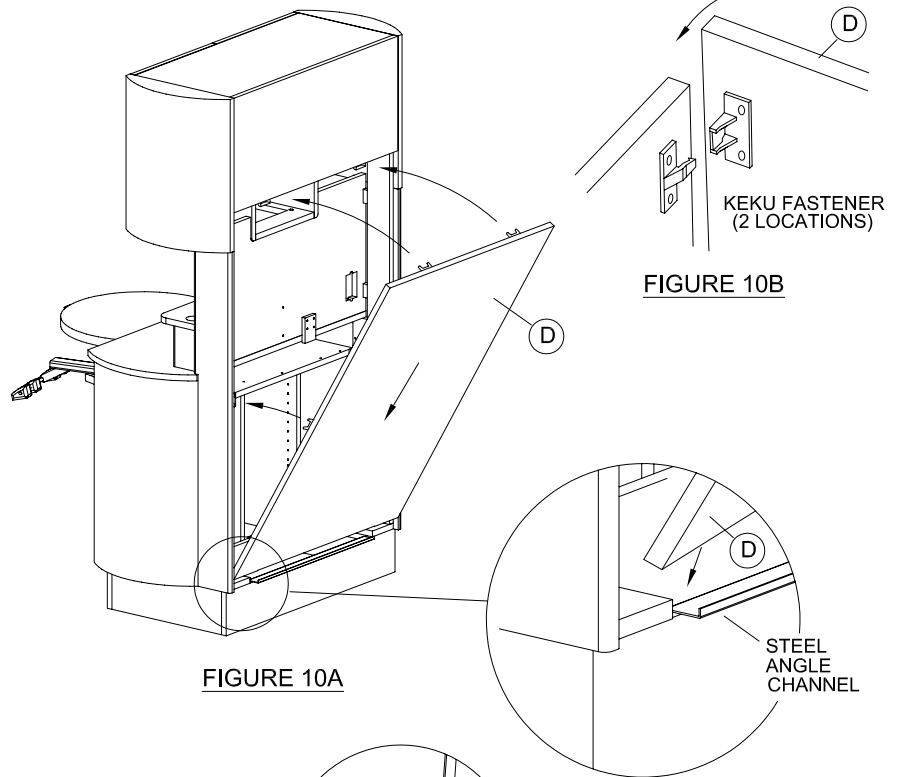

FIGURE 10A

FIGURE 10B

STEEL ANGLE CHANNEL

KD CONNECTORS
(2 LOCATIONS)

COUNTER TOP
SHOWN BROKEN
AWAY TO SEE KD

A

FIGURE 10C

KD CONNECTORS
(2 LOCATIONS)

FIGURE 10E

FIGURE 10D

D-66CM Assembly Instructions

Step 11

Remove upper doors (to install glass shelves) by opening doors and pulling up on the tab at the end of the hinge base plate mounted on the inside of the cabinet. See Figure 11A

Insert glass shelf support pins (4 for each glass shelf) into holes on the inside end panels and then set glass shelves (B) onto the support pins. See Figure 11B. For glass locations See Figure 11C.

Replace the doors by lining up the hinge and hinge plate then snap the hinge in place. See separate instruction page regarding adjusting the hinges if the doors are not properly aligned.

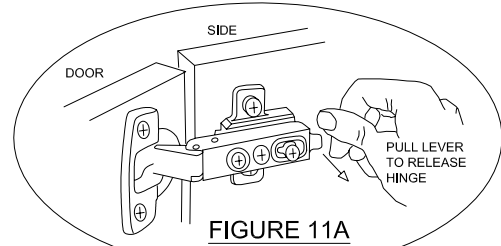

FIGURE 11A

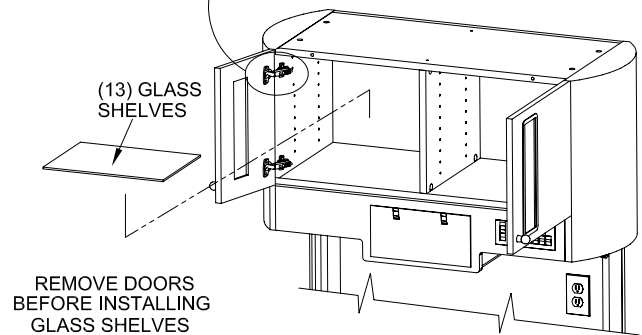

FIGURE 11B

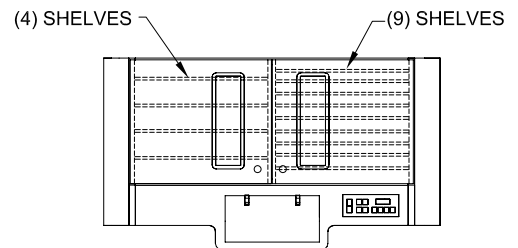

FIGURE 11C

Step 12

Replace the removable hole covers (A1). See Figure 12.

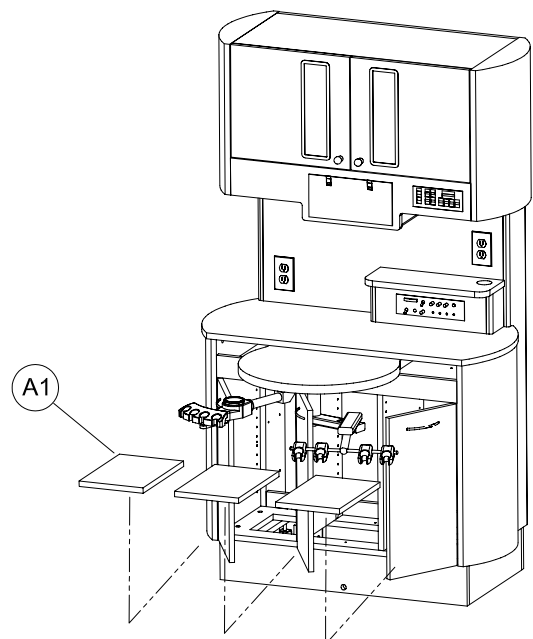

FIGURE 12

Installation Complete

CLOCK/TIMER/CONTROL PANEL OPERATION

Note: The ON/OFF buttons control the fluorescent light fixture. They have no effect on the clock/timer.

➤ **Setting the clock:**

- 1 – Press CLOCK to select clock mode.
- 2 – While pressing the SET button, press the HOUR and MIN buttons to set the correct time. The SEC button has no function in clock mode.

➤ **Using the countdown timer:**

- 1 – Press TIMER to enter timing mode.
- 2 – While pressing the SET button, press the MIN and SEC buttons to select the desired time. The timing range will be 1 second to 30 minutes. The HOUR button has no function in timer mode.
- 3 – Press START TIMER to start the countdown. A 10 second beeper will briefly sound at the end of the interval. If you want to stop the beeper early press RESET to silence the beeper.
- 4 – For repeatedly using the same interval, the timer remembers the last time entered. Press RESET to restore the last interval.

CLOCK/TIMER/CONTROL PANEL FACE

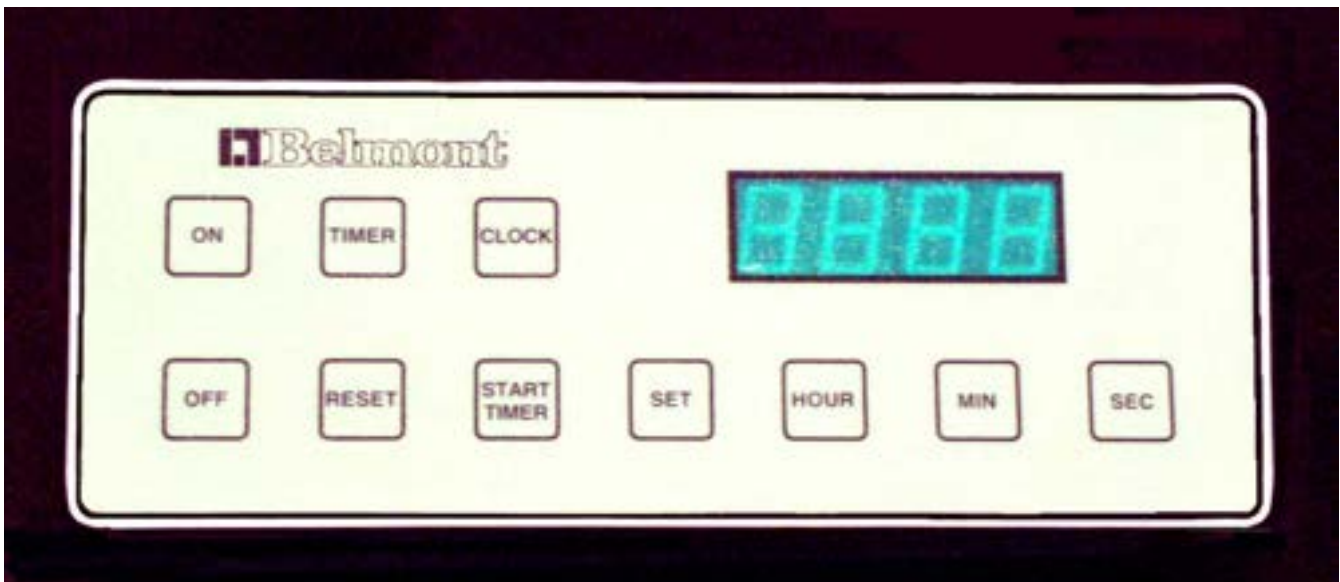

D-66CM Electrical Parts List

1. Junction box w/cover, galvanized steel. Overall dimensions, 4" long, 2 1/8" wide, 1 1/2" deep, .07" thick. U.L. listed or equal.
2. Internal cords are 12/3 AWG, TYPE SO, SOO, SJ, SJT, SJO, or SJTO insulated, rated 300 VAC, 60°C, U.L. listed or equal. Cabinet between receptacles and timers (unit provided with timers) are minimum 14/3 AWG, type SO, SOO, SJ, SJT, SJO or SJTO insulated, rated 300 VAC, 60°C.
3. Conduit connector, 3/8" insulated. U.L. listed or equal.
4. Vinyl insulated butted seam ring, wire rated 12-10 AWG. U.L. listed or equal.
5. Wire connectors (wire nut), screw on type. U.L. listed.
6. Flexible conduit, flexible steel conduit, 1/2". U.L. recognized or equal.
7. Receptacle, duplex 2-pole 3 wire grounding hospital grade, rated 125 VAC, 15 AMPS. U.L. listed or equal.
8. Wall plate, duplex, U.L. listed.
9. Fluorescent lamp assembly, see ETL report no. 482012, page 17.
10. Clock/timer, see ETL report no. 482012 page 18, 19.

D-66CM X-Calibur Electrical Instructions

IMPORTANT NOTE: Approved electrical components and designs are used in the X-Calibur cabinet; however, the procedures described herein must be performed by a licensed electrician using approved methods and materials according to the local code governing the installation site.

General Electrical Notes

- Each cabinet should be wired to a **SEPARATE 15 Amp circuit**.
- Unless otherwise specified, **ALL WIRING** supplied by the contractor must be **APPROVED 12 Ga. AWG**.
- Type B equipment providing a particular degree of protection against electric shock, particularly regarding: allowable leakage current, & reliability of the protective earth connection (if present).
- Disconnect device must be provided in the branch circuit by electrician.

* You have the option of wiring the fluorescent light in this cabinet to an adjacent cabinet (D-2 unit). All lights in a treatment area can thus be activated from a single washable switch. See information below.

- 1) Bring flexible conduit (building wire) up to j-box (supplied by contractor) near back of the clock/timer.

Note: It is advisable that the back panel of the cabinet be removed or left open during this procedure to improve access.

- 2) Run wires from the hookup junction box to the D-2 junction box.
- 3) D-5CM fluorescent light wire to be cut and connected to lead wires using wire nuts (see wiring diagram)
- 4) D-2 fluorescent light wires to be connected to lead wiring. Close j-boxes with covers.

The remote switching system can accommodate the **FLUORESCENT FIXTURE ONLY**. **DO NOT** add any other loads to the remotely switched circuit. Approved 16ga AWG wiring may be used for the lamp feed **ONLY** if it is acceptable for this use under local code.

- 5) Q aOption 90-937 for additional 15 amp duplex receptacle can be located on the bottom of the left side column. Separate 15 amp circuit must be wired by local licensed electrician (by customer).

Typical Wiring for Remote Activated Lights

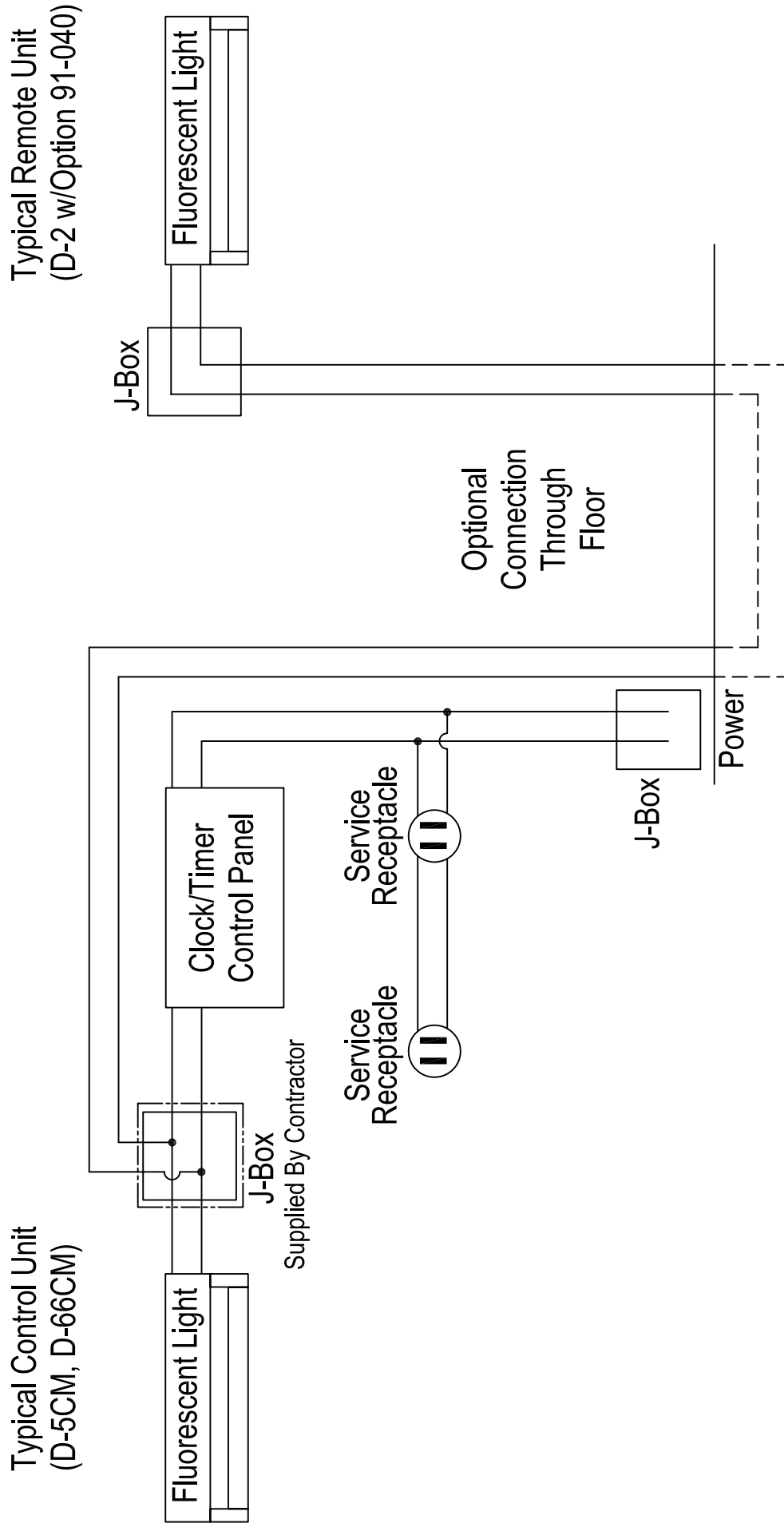

X-CALIBUR™ CABINETRY SYSTEM

LAMINATE SURFACE CLEANING INSTRUCTIONS

The disinfectant solution should be applied in accordance with the instructions provided by the manufacturer. The following solution is recommended for laminate surfaces, it may also be used on metal and glass surfaces.

Product	Manufacturer
Birex ®	Biotrol International
Kodak Clinasept	Kodak
Foaming Disinfectant	Catalogue No. 829-5230

Koken not responsible for any changes made by the manufacturer in the chemical composition of the cleaning solution listed above, which may effect the finishing after application.

SOLID SURFACE VENEER

CLEANING, CARE AND MAINTENANCE

In most cases, caring for your solid surface veneer countertop or surface is as simple as wiping the surface with a damp cloth. If a stain develops, wipe it away with soap and water. Or if you prefer, wipe it clean with Windex® - **not 409® or Fantastic®**. **NOTE: The cleaning chemicals used to clean Laminate material are not to be used on solid surface veneer material, such chemicals may damage the solid surface veneer material.**

If a stain doesn't respond to soap and water, for a matte finish, apply an abrasive cleanser and buff with a Scotch-Brite® pad using a circular motion. The same technique can be used for cigarette burns.

For minor cuts and scratches, simply sand lightly with medium (180 grit) sandpaper, then follow with a fine (220 grit) sandpaper. Finally touch up the finish by buffing with a Scotch-Brite® pad.

PRECAUTIONS:

Do not expose the surface to harsh chemicals, such as chloroform, eugenol, methyl ethyl ketone, paint remover, turpentine, nail polish remover or stove and drain cleansers. If these chemicals come in contact with the surface, immediately wash them off with water, using appropriate safety measures to avoid injury.

In case of staining or spotting, sand lightly with fine sandpaper, then buff in a circular motion with a Scotch-Brite® pad. Hot pans or heat-producing appliances can mar your solid surface veneer surface when placed directly on the countertop. Always use a trivet with legs. Care should be taken in order to keep the surface looking as good as new.

NOTE: The warranty shall not apply to defects or damages arising from any of the following:

- Accidents abuse or misuse of chloroform, eugenol and solvents such as acetone/M.E.K. These chemicals can possibly damage and discolor solid surface veneer materials if in contact over time.
- Exposure to extreme temperatures.
- Improper maintenance.

Koken not responsible for any improper care of solid surface veneer material and that any warranty will be void.

CAMBRIA QUARTZ SURFACES

CLEANING, CARE AND MAINTENANCE

Cambria is care free therefore no sealing, buffing, polishing or reconditioning required. Using soap and water is sufficient to clean the Cambria surface.

Adjustment Instructions for Concealed Hinges and Drawers

3-Dimension Adjustment for Snap-On Hinge

Note: Remove Cover Cap

Allows for three-way adjustments in the hinge arm.
The side adjustment is a micro adjustment. The depth and height adjustment is held by a grid system.

Use #2 POZIdrive screwdriver to adjust screws.

- 1 – Side adjustment
- 2 – Depth adjustment
- 3 – Height adjustment

Release Latch

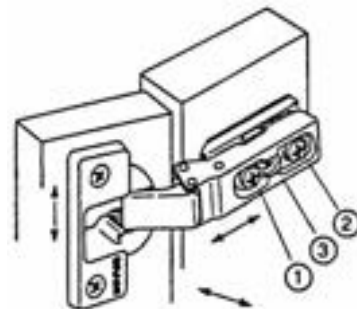

Adjustment for Drawer

- 1 – Height adjustment: Loosen screws **B** slightly. Adjust screw **A** (adjustment +/- 2mm). Tighten screws **B**.
- 2 - Side adjustment: Loosen screws **B** slightly. Adjust front to required position (adjustment range +/- 1.5mm). Tighten screws **B**.

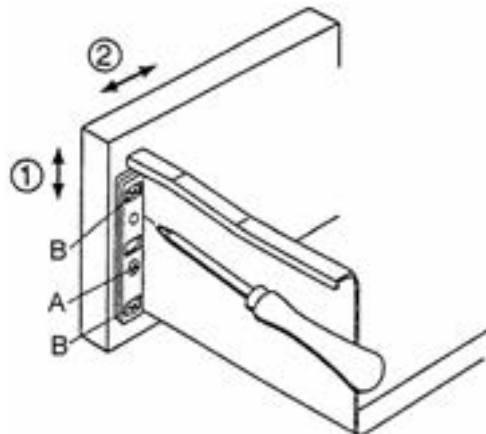



DETAIL OF AIR, WATER, AND VACUUM STUBS
(STOP VALVES SUPPLIED WITH CABINET)

NOTE: PLAN AND ELEVATION
VIEWS ARE FOR REFERENCE
ONLY. SEE INSTALLATION
MANUAL FOR DETAILED
INFORMATION.

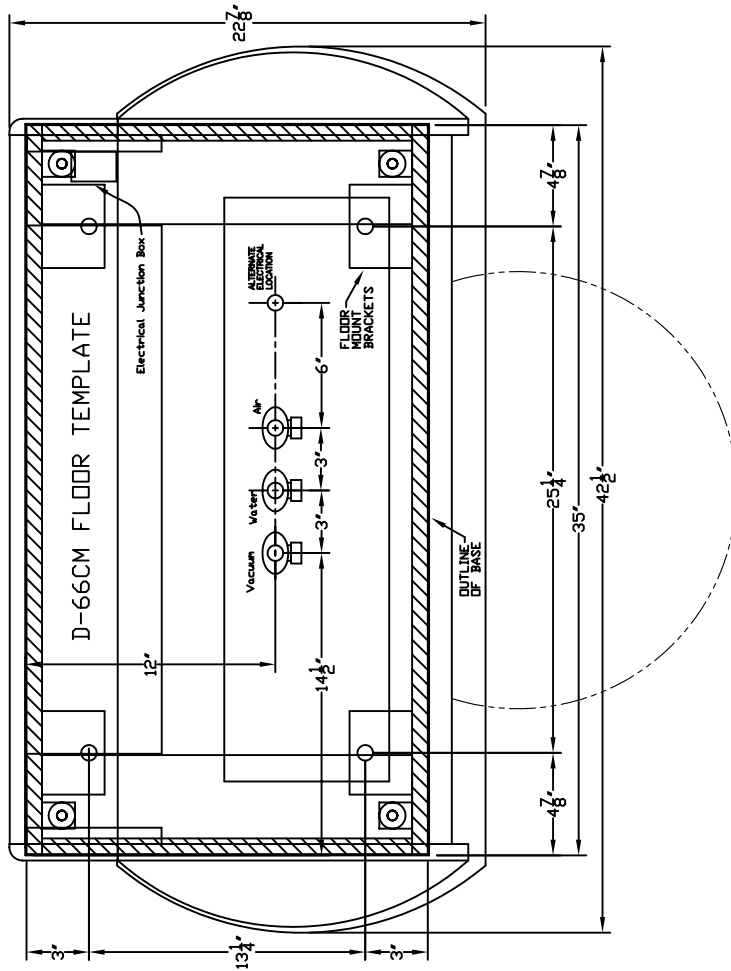
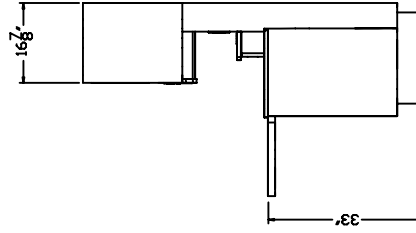
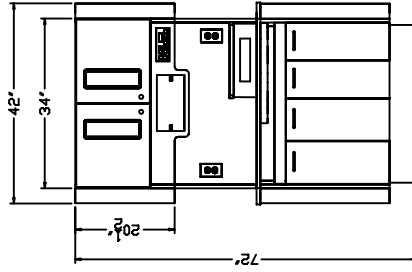
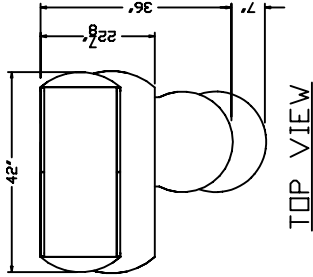

IMPORTANT NOTE:
PLUMBING LOCATIONS SHOWN ARE TYPICAL FOR
DELIVERY SYSTEMS CURRENTLY AVAILABLE. THE
PLUMBING HARDWARE IS NOT SUPPLIED WITH THE
CABINETRY; IT IS NOT REQUIRED UNLESS A DELIVERY
SYSTEM IS BEING INSTALLED. WE RECOMMEND YOU
REVIEW THE TEMPLATE SUPPLIED BY THE DELIVERY
SYSTEM MANUFACTURER WHEN PLANNING THIS
PLUMBING LAYOUT.

NOTE: IF A NITROUS ANALGESIA SYSTEM IS
TO BE INSTALLED, LOCATE THE PIPING IN
THE AREA INDICATED, BECAUSE OF THE
DIFFERENCES IN SYSTEM HARDWARE. EXACT
LOCATIONS MUST BE DETERMINED BY INSTALLER.

KOKEN MANUFACTURING ASSUMES NO
RESPONSIBILITY FOR MEASUREMENTS
MADE BY THE INSTALLER. THE LOCATION OF
ELECTRICAL SOURCES OR CORRECT
LOCATION OF THE PIPING IN THIS LOCAL
MEASUREMENTS ON THIS DRAWING ARE
FOR YOUR INFORMATION ONLY. LOCAL
FOR YOUR INFORMATION ONLY. LOCAL
CODE REGULATIONS SHOULD BE
CHECKED WITH THE ARCHITECT OR
ENGINEER BEFORE WORK
IS STARTED.

REV.	DATE	DESCRIPTION	BY
		KOKEN MANUFACTURING CO., INC.	
MATERIAL			
FINISH			
TITLE			
D-66CM FLOOR TEMPLATE			
DRAWN BY			
ST. LOUIS, MISSOURI			
SCALE			1-1
DATE			5/23/2003
DRAWING NO.			P11347