

Installation Instructions & Owners Manual

**E-Series Dental Cabinetry
Model: E-7-DS / E-7-LS / E-7-RS**



E-7-DS

Consumer: Please retain these instructions for future use.

Version: 04012013



1631 Dr. Martin Luther King Drive
St. Louis, MO 63106
(314) 231-7383 (888) 833-3682
Fax (314) 621-2296
www.belmontequip.com

General Cabinet Handling Information

Models: E-7-(DS,LS,RS)

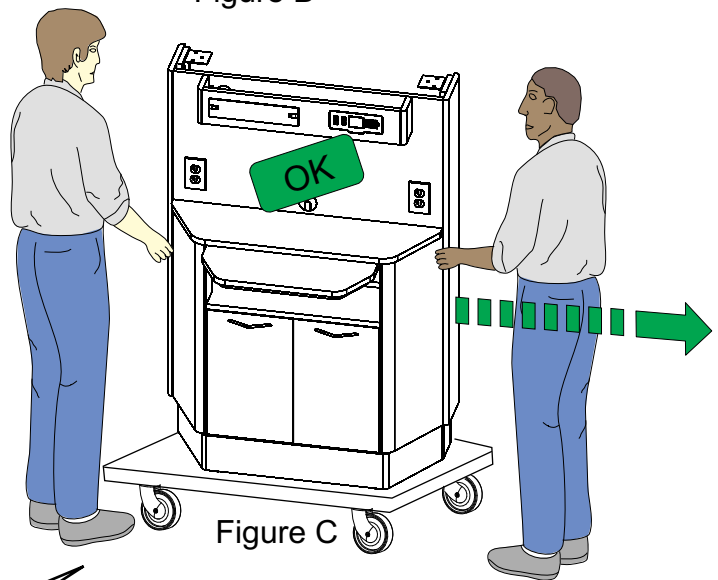
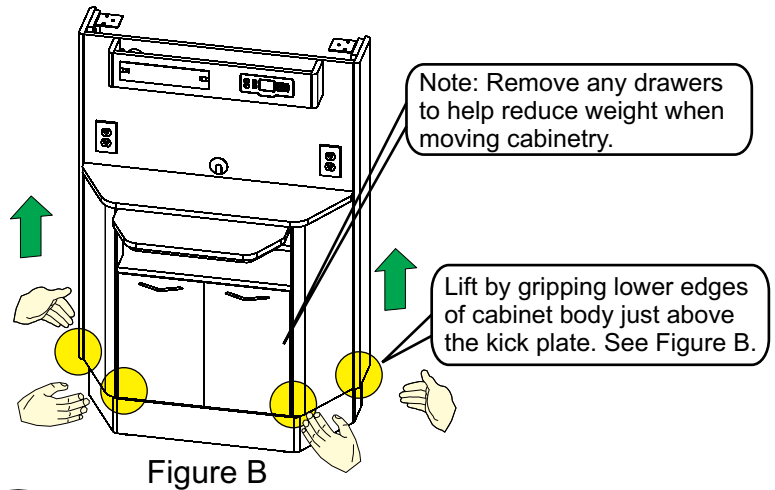
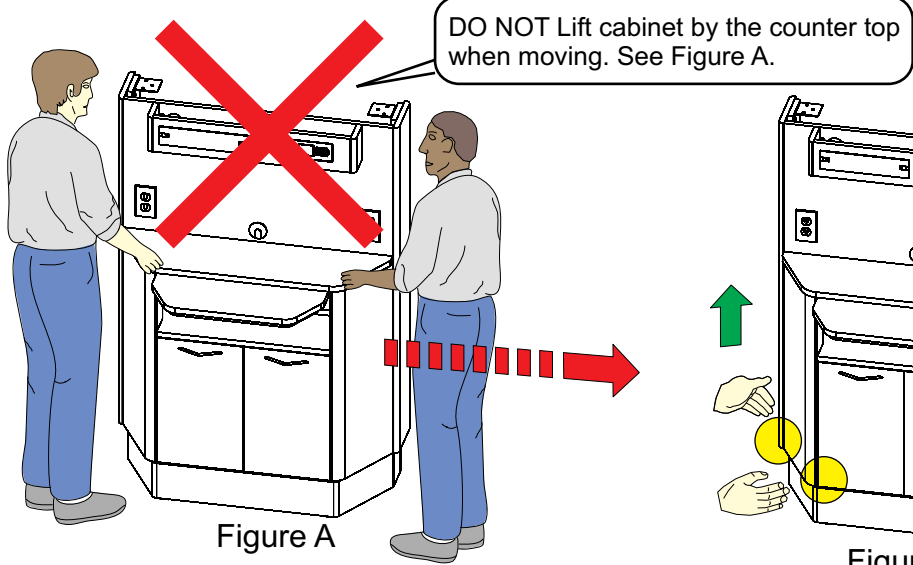

Move by using some type of roller dolly, slings or a comparable moving aid. See Figure C and D.

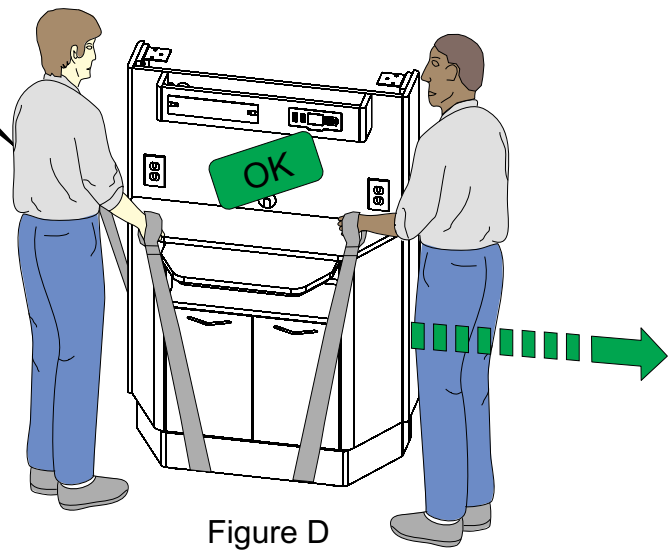

Sliding Top Warning
Model: E-7-(DS,LS,RS)

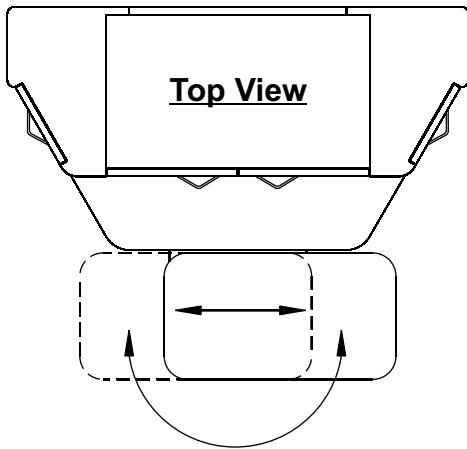

When using work surface top, make sure it is in fully turned position and secured to the magnetic catch before using.

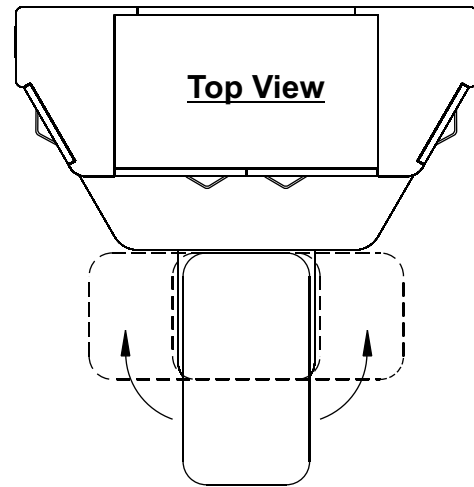

Do NOT use work surface top in this unsecure position.
(Rotate it as shown in either direction)

Failure to properly locate the sliding top may cause damage to the sliding top mechanism or structural components of the cabinetry.



1631 Dr. Martin Luther King Drive
St. Louis, MO 63106
(314) 231-7383 (888) 833-3682
Fax (314) 621-2296
www.belmontequip.com

Detail Drawings

Model: E-7-DS

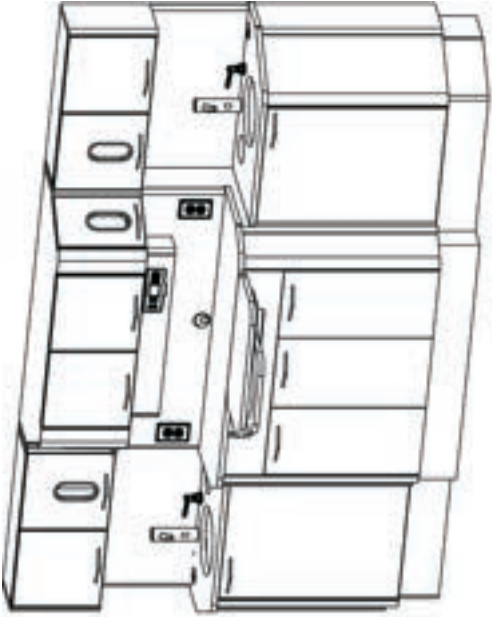

ISOMETRIC VIEW



RIGHT SIDE VIEW



TOP VIEW

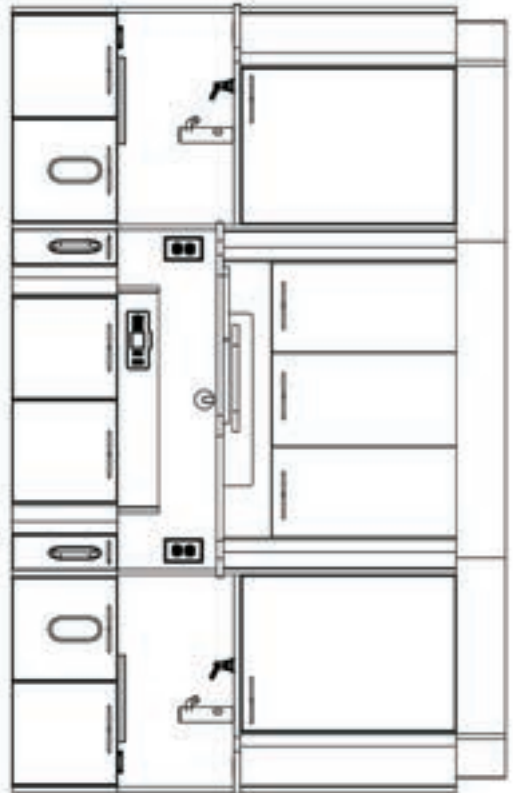

FRONT VIEW

Detail Drawings
Model: E-7-LS

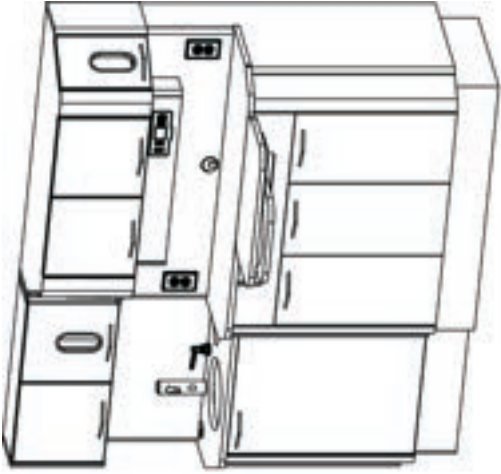

ISOMETRIC VIEW

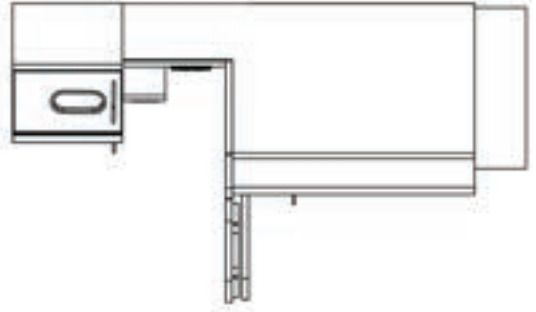

RIGHT SIDE VIEW

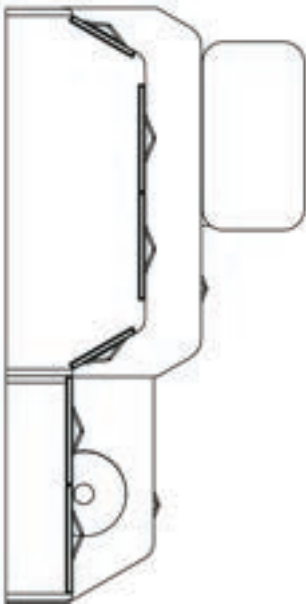

TOP VIEW

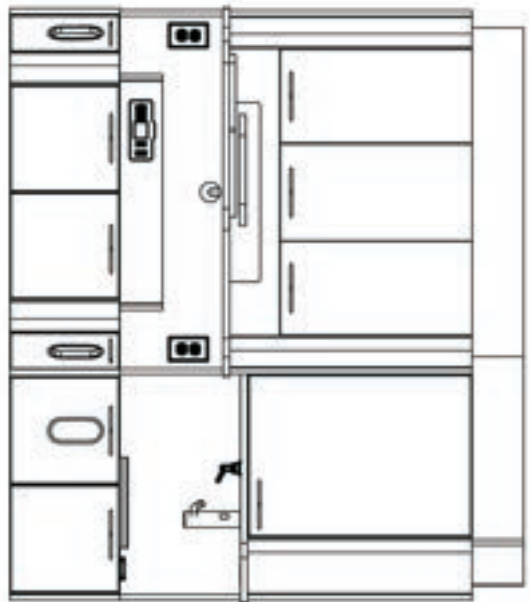

FRONT VIEW

Detail Drawings

Model: E-7-RS

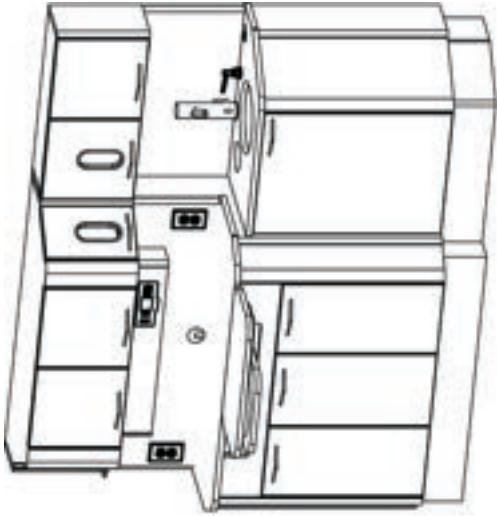

ISOMETRIC VIEW

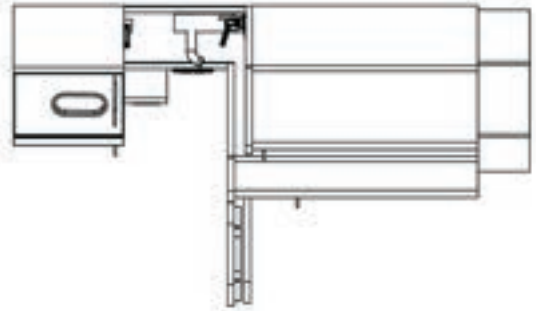

RIGHT SIDE VIEW

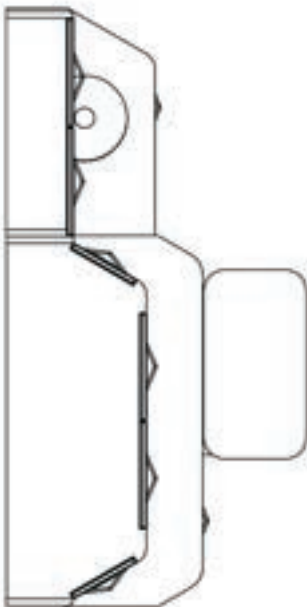

TOP VIEW

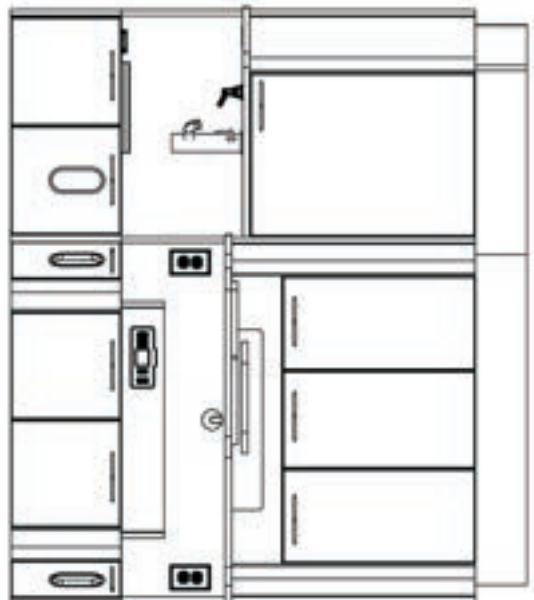

FRONT VIEW

Detail Drawings
Model: E-7-DS w/ Glass Bowl

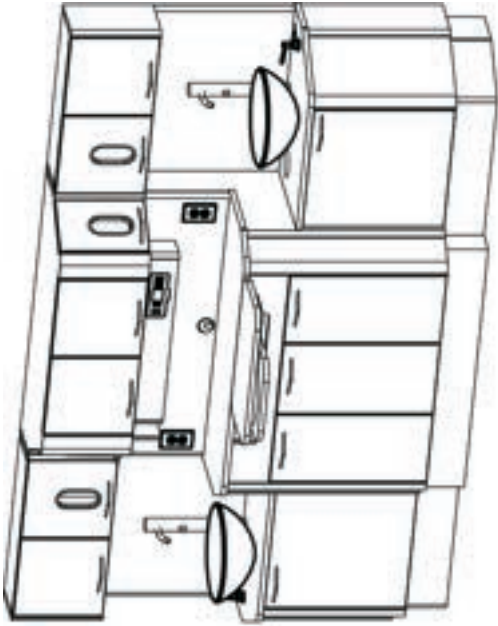

ISOMETRIC VIEW

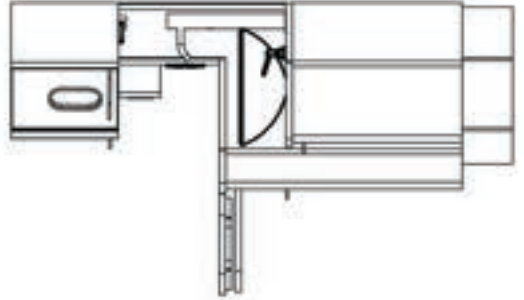

RIGHT SIDE VIEW



TOP VIEW

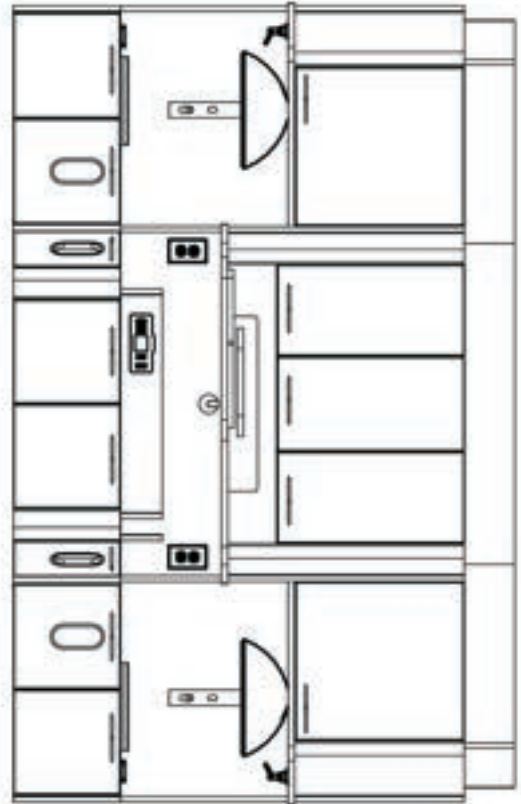

FRONT VIEW

Detail Drawings
Model: E-7-LS w/ Glass Bowl

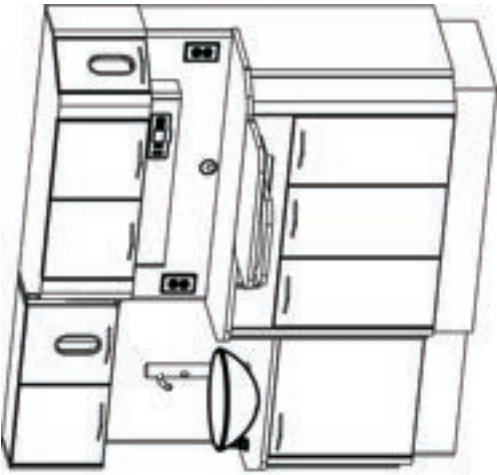

ISOMETRIC VIEW

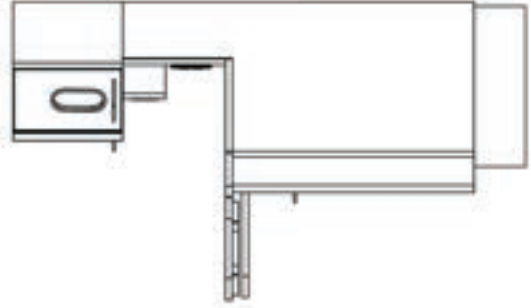

RIGHT SIDE VIEW

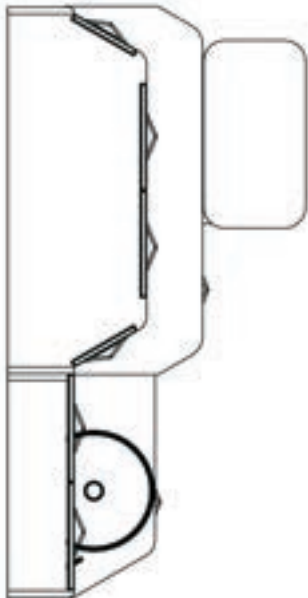

TOP VIEW

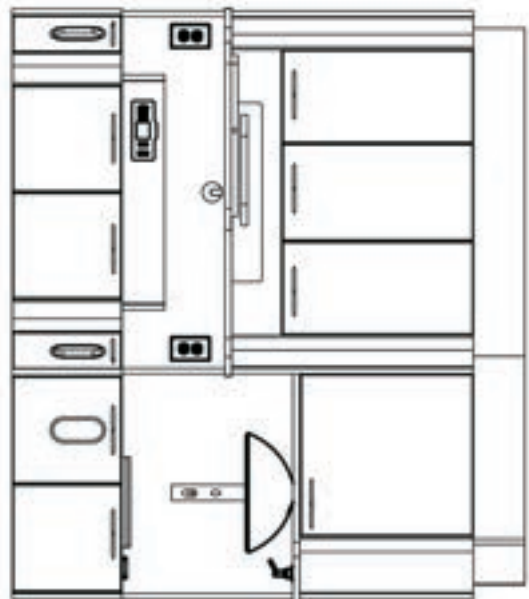

FRONT VIEW

Detail Drawings
Model: E-7-RS w/ Glass Bowl

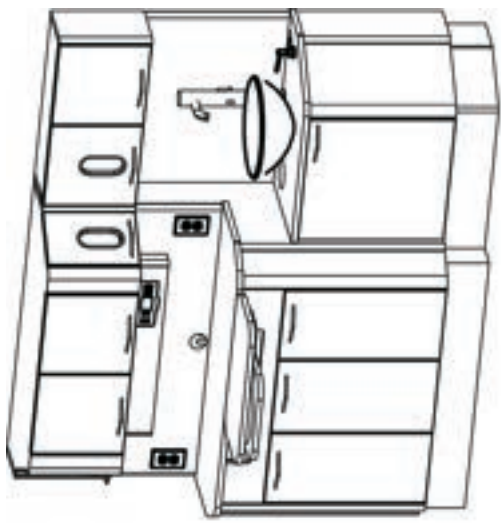

ISOMETRIC VIEW

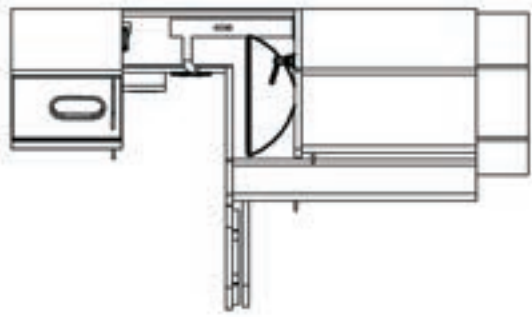

RIGHT SIDE VIEW

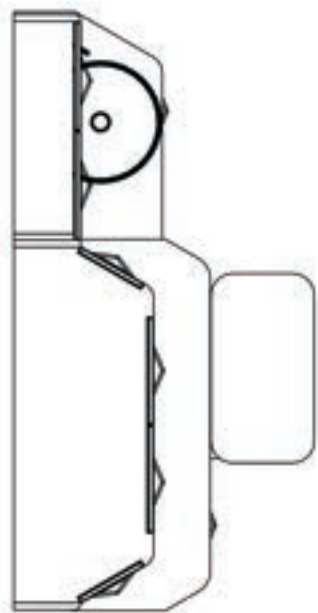

TOP VIEW

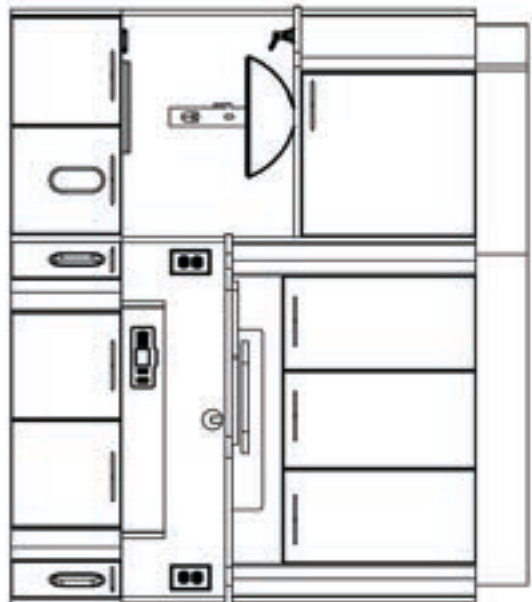

FRONT VIEW

Assembly Instructions

Model: E-7-(DS,LS,RS)

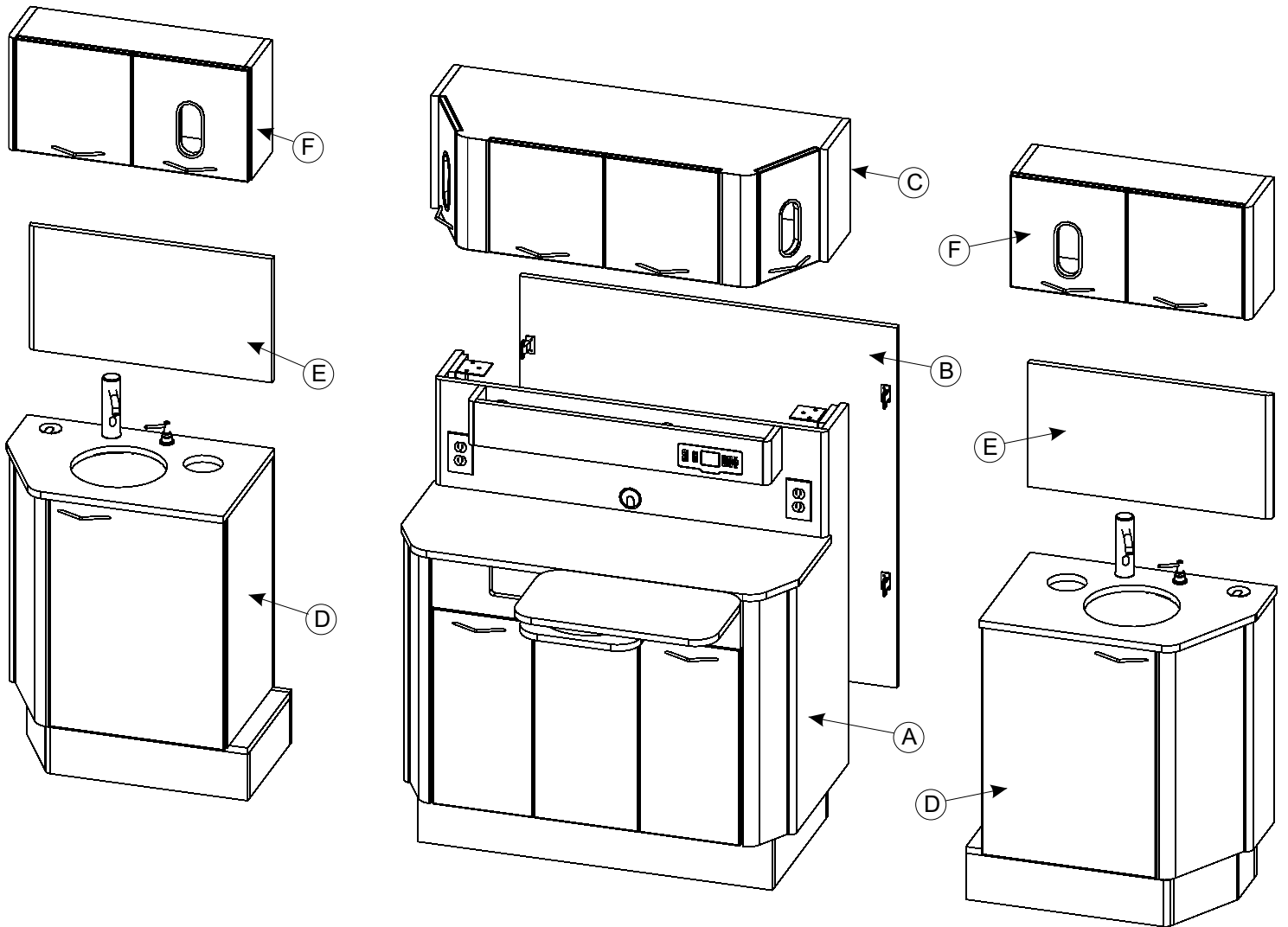

Model: E-7-DS
Shown

Component Identification

- (A) Lower Cabinet
- (B) Lower Cabinet Back Panel
- (C) Lower Cabinet Upper Storage
- (D) Lower Sink Cabinet
- (E) Lower Sink Cabinet Splash
- (F) Lower Sink Cabinet Upper Storage

Note: Back Panel (Item B) attached to Cabinet Base (Item A) during shipping.

Assembly Instructions

Model: E-7-(DS,LS,RS)

Note:

These instructions show only a Right Sink Cabinet being installed. The same steps will apply to attach a Left Sink Cabinet. If you have a DS model you will have Sink Cabinets at each ends. If you have an LS or RS model the Sink Cabinet will be either on the left end (LS) or right end (RS). The E-7G models assemble the same except for the need to mount the glass sink bowl.

Step 1

Check the incoming power and plumbing rough-in locations to see if they conform to the cabinetry configuration. Locate and drill the holes in the floor for securing the bases to the floor. If a dental delivery system is to be installed on this cabinet, confirm that the appropriate air, water and vacuum plumbing stubs are in place.

Step 2

Remove the Back Panel (B) from the Lower Cabinet (A) sides (see Figure 1A) by pulling the top of the Back Panel from the rear of the cabinet to release the upper Keku Latches and continuing pulling back to release the lower Keku Latches (4 locations).

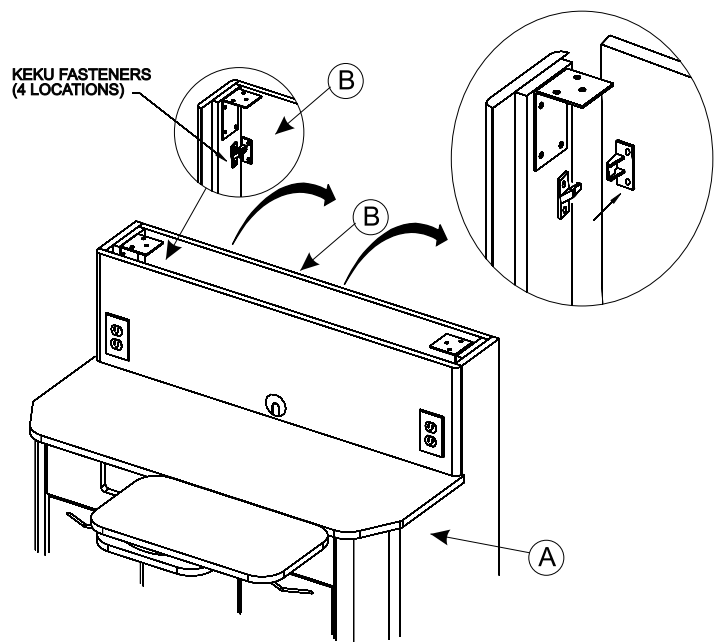

Figure 1A

Step 3

Open the Doors (A1) and remove the Bottom Covers (A2) (see Figure 2). You may need to tilt the bottom covers to remove from door opening.

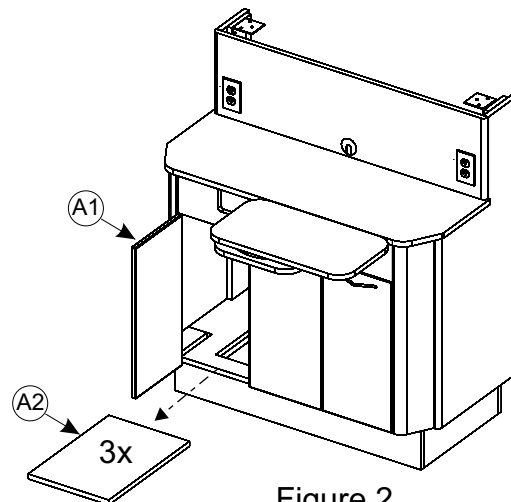

Figure 2

Assembly Instructions

Model: E-7-(DS,LS,RS)

Step 4

Place Lower Cabinet Upper Storage (C) onto metal brackets located at the top of the Lower Cabinet sides. Line up the holes with in the metal brackets with the holes in the bottom of the Upper Storage (see Figure 3).

Insert a 1/4-20 hex bolt (C1) with a Lock Washer (C2) and Flat Washer (C3) into each hole and wrench down about half way on each bolt. Once each bolt is properly threaded into the bracket, tighten all (6) bolts. (Caution: Do Not Over-tighten)

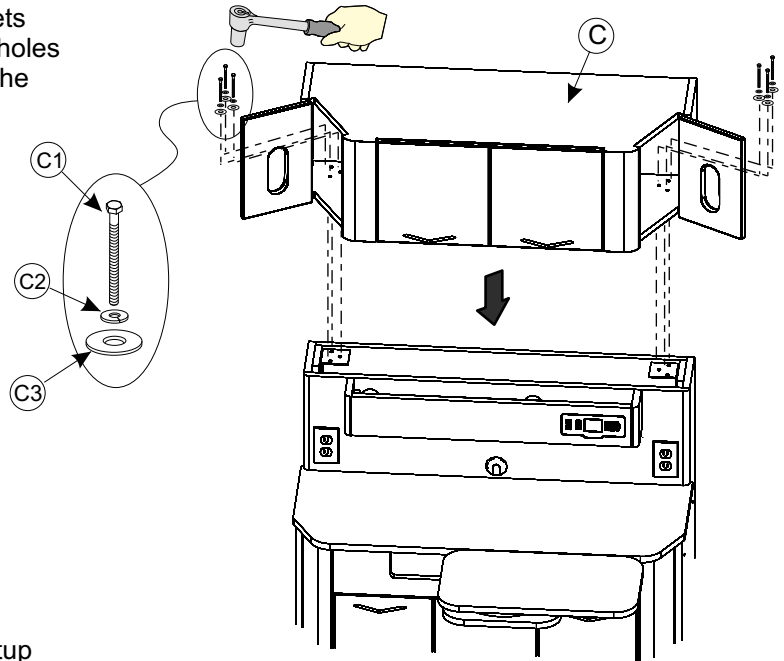

Figure 3

Step 5

If equipped with a BDS-2561 (see Figure 4A). Refer to instructions that came with the unit for further setup and connections.

If equipped with a BDS-2563 (see Figure 4B). Refer to instructions that came with the unit for further setup and connections.

Install Arm and Holder System

Figure 4A
BDS-2561

- 1 - Locate mounting plate hole pattern under the sliding counter top and fasten the arm assembly to the underside using the 10-32 screws provided. Position the 90° handpiece tubing manifold towards back of the cabinet.
 - 2 - Install the self-contained water system and route its umbilical to the utility center. Connect the water system tubing to their appropriate connections.
 - 3 - Connect the delivery system umbilical tubing to the appropriate barbs on the panel mount unit.
 - 4 - Connect the panel mount umbilical tubing to the appropriate barbs on the floor utility.
 - 5 - Connect the foot control tubing to the appropriate barbs in the utility center.
 - 6 - Slide the panel mount unit into the opening in the cabinet. The tubing will act as a weight giving you time to check for any air or water leaks.
 - 7 - Align the screw holes on the faceplate with the four pilot holes on the cabinet surface and secure the unit with the four #6 stainless phillips wood screws provided.
- *Alternative stud mounting faceplate:
5/32" dia. x 4 hole thru the four pilot holes on the cabinet surface and secure the face plate with the #6-32 x 4 nuts and lock washers.

For Water Bottle mounting information see separate "Water Bottle Mounting" page.

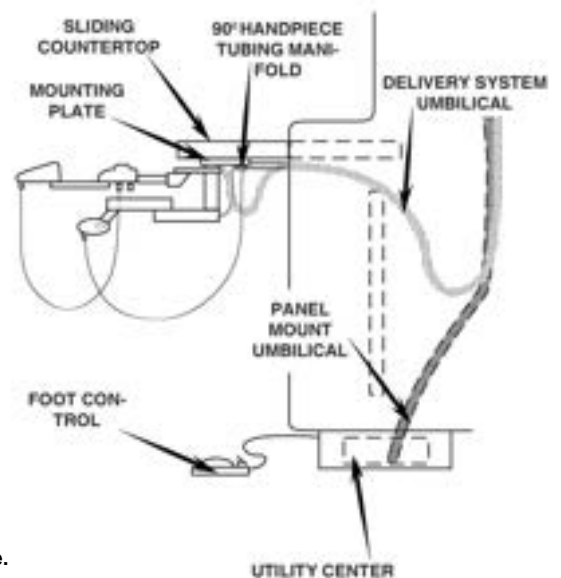

Assembly Instructions

Model: E-7-(DS,LS,RS)

Step 5 (continued)

Install Arm and Holder System

- 1 - Locate mounting plate hole pattern under the sliding counter top and fasten the arm assembly to the underside using the 10-32 screws.
- 2 - Install the self-contained water system and route its umbilical to the utility center. Connect the water system tubing to their appropriate connections.
- 3 - Make all appropriate tubing connections for the delivery systems.

For Water Bottle mounting information see separate "Water Bottle Mounting" page.

Figure 4B
BDS-2563

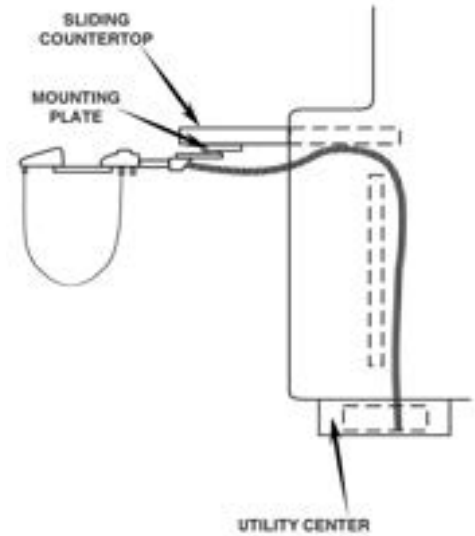

Step 6

Replace the Back Panel (B) by seating the bottom edge into the steel angle channel at the bottom of the rear opening (see Figure 5). Tilt the top edge inward until all (4) Keku Latches are fastened. You may need to use a rubber mallet to tap the panel into position.

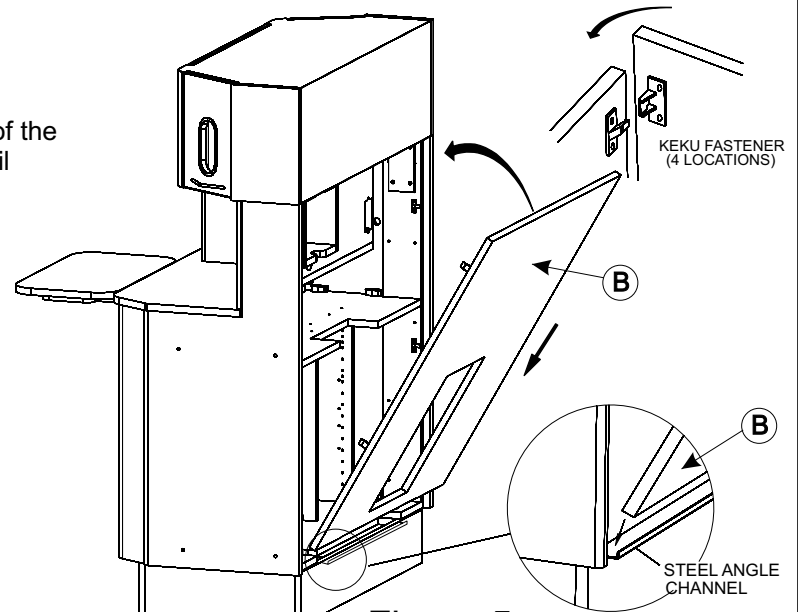

Figure 5

Assembly Instructions

Model: E-7-(DS,LS,RS)

Step 7

The cabinet may now be moved into its final location and mounted to the floor. Mount the (4) Floor Mounting Brackets (A4) to the floor using proper fasteners for the floor being mounted to (see Figure 6).

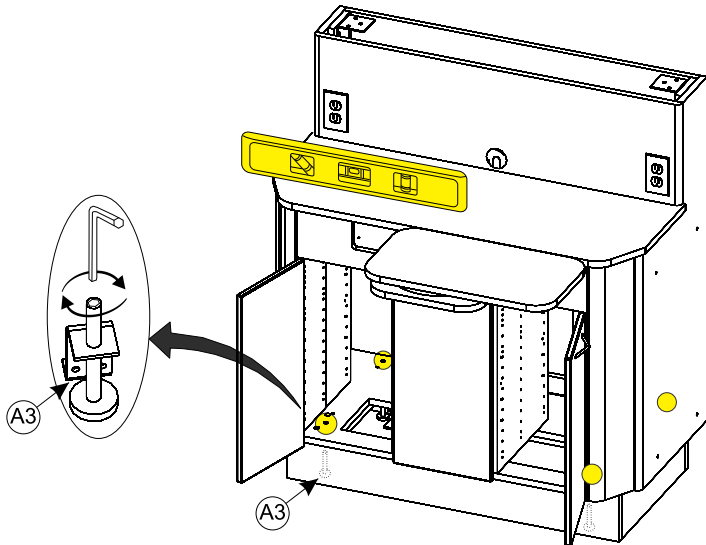

Figure 7

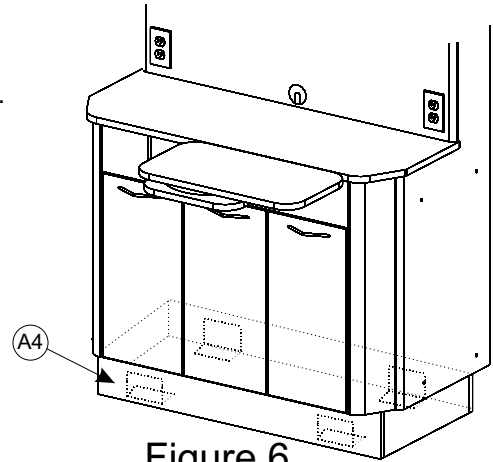

Figure 6

Step 8 **IMPORTANT**

Adjust the (4) Leveling Feet (A3) to level the cabinet using a 5mm allen wrench. Each Leveling Foot has access to the allen head through a hole in the bottom cabinet. (see Figure 7)

Do not mount the cabinet to the floor using the floor mounting brackets until the cabinet is pushed backed to the wall and the Back Panel is re-installed.

Step 9

Remove the Bottom Cover (D1) from the Sink Cabinet (D).

Mount the Sink Cabinet (D) to the proper end of the Lower Cabinet (A) using (4) 1/4-20 Connecting Bolts (see Figure 8). Tighten bolts using a 4mm allen wrench.

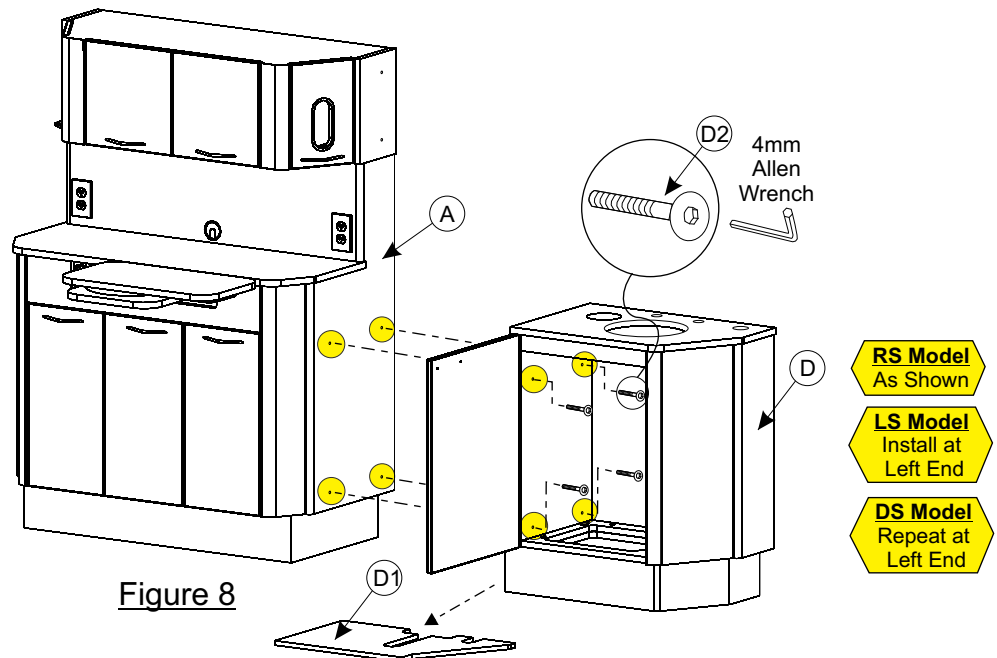

Figure 8

Assembly Instructions

Model: E-7-(DS,LS,RS)

Step 10 **IMPORTANT**

Adjust the (4) Leveling Feet (D3) to level the cabinet using a 5mm allen wrench. Each Leveling Foot has access to the allen head through a hole in the bottom cabinet. (see Figure 9)

Mount the Floor Mounting Bracket (D4) to the floor using proper fasteners for the floor being mounted to (see Figure 9).

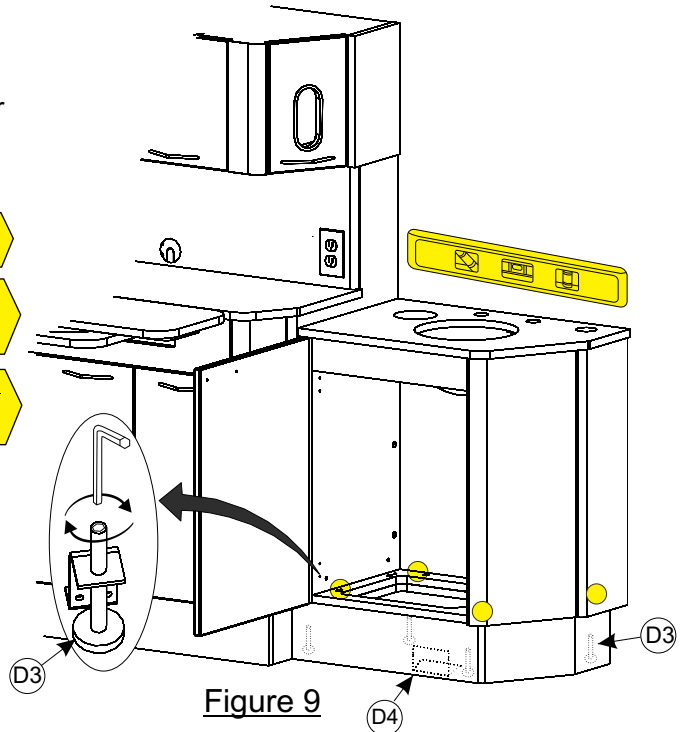

Figure 9

RS Model
As Shown

LS Model
Do at
Left End

DS Model
Repeat at
Left End

Note: Test fit splash prior to gluing into place

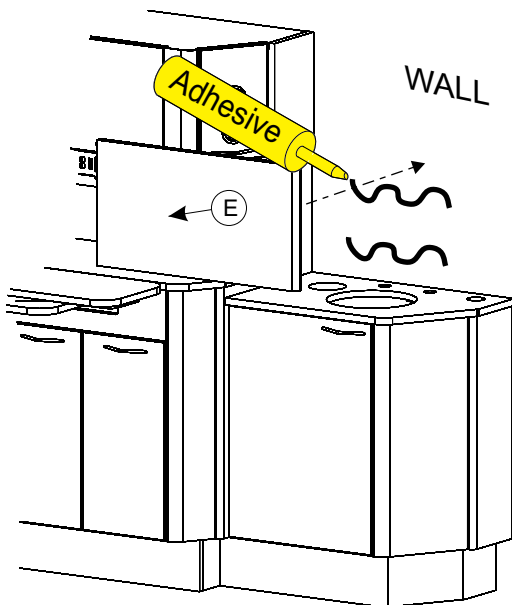

Figure 10

RS Model
As Shown

LS Model
Do at
Left End

DS Model
Repeat at
Left End

Step 11

Mount the Lower Sink Cabinet Splash (E) to the wall by applying Adhesive to the wall then place splash into position (see Figure 10).

Step 12

Seal splash and countertop locations shown using clear silicone rubber (see Figure 11).

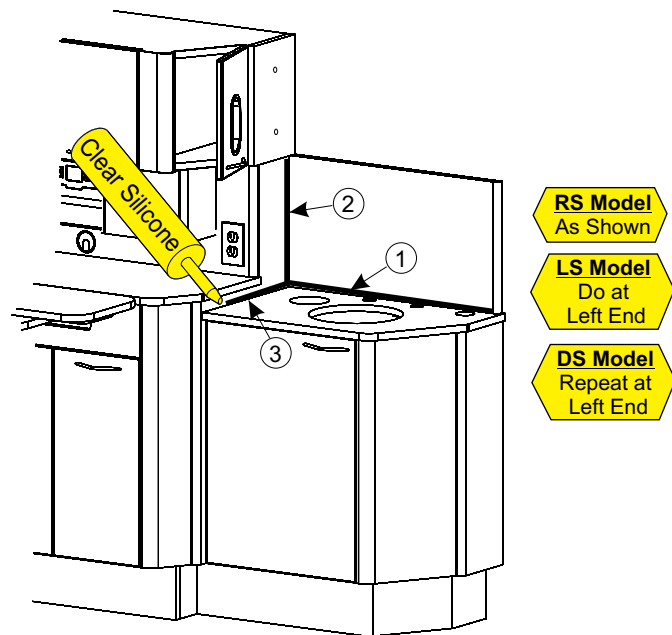

Figure 11

RS Model
As Shown

LS Model
Do at
Left End

DS Model
Repeat at
Left End

Assembly Instructions

Model: E-7-(DS,LS,RS)

Step 13

Place Upper Storage (F) into position and secure to the Upper Storage (C) using (2) male/female 1/4-20 Connecting Bolts. From inside the Upper Storage (C) insert (2) Female Connectors (F1) and from inside the Upper Storage (F) insert (2) Male Connectors (F2) and tighten (see Figure 12).

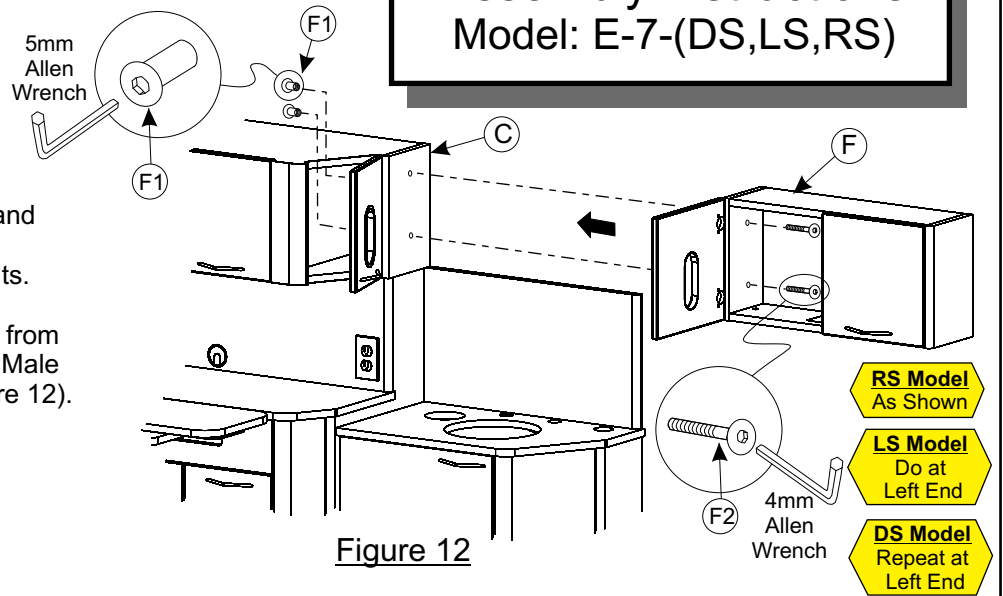

Figure 12

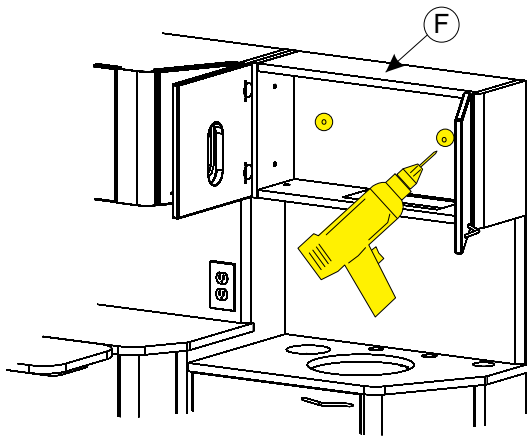

Figure 13A

- RS Model**
As Shown
- LS Model**
Do at
Left End
- DS Model**
Repeat at
Left End

Step 14

Important!

Before drilling the holes through the Upper Storage (F) for securing it to the wall you will need to decide what type of fastener to use depending on the walls construction. It is recommended to fasten into structural members where possible such as wood or metal studs. You may screw directly into studs with the appropriate screw type.

If screwing thru to a stud you may drill appropriate sized holes (2 recommended) thru the Upper Storage back panel at needed locations to hit wall studs (see Figure 13A). Screw directly thru the Upper Storage back panel into the stud with the appropriate screw type .

If mounting the cabinet to drywall you may use zip-it screws with #8 x 1 1/2" pan head screws (see Figure 13B) or molly wall anchors (see Figure 13C). Drill (2) 3/16" dia. holes thru the Upper Storage back panel into the wall. Remove Upper Storage unit by removing the connecting bolts from the previous step. Drill appropriately size holes in the drywall to accommodate the Zip-It or molly anchors at the hole locations you previously drilled. Insert and secure Zip-It or Molly anchors then reinstall Upper Storage. Screw thru back panel into zip-it or molly screw.

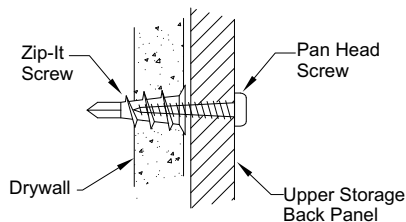

Figure 13B

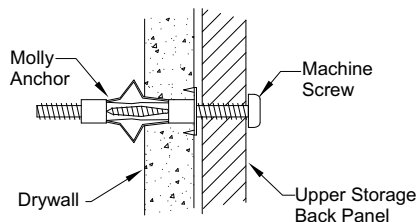

Figure 13C

Assembly Instructions

Model: E-7-(DS,LS,RS)

Step 15

Make electrical connections per the E-7 Electrical Schematic & Instruction sheets.

Make plumbing connections including installation of the faucet(s) and soap dispenser(s). If the E-7 w/ Glass Bowl option (see Figure 14) is being installed see separate "Glass Bowl Installation" page.

Make drainage plumbing connections to the sink bowl per local plumbing codes. See separate "Loop Venting Guidelines" page for further information.

Make connections to rough-ins for delivery system if applicable.

- RS Model**
As Shown
- LS Model**
Do at
Left End
- DS Model**
Repeat at
Left End

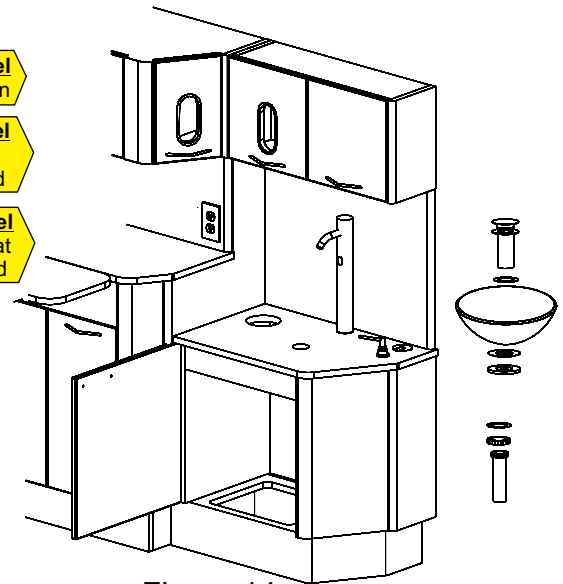

Figure 14

Step 16

Open doors on Sink Cabinet Upper Storage (F) and install Towel Dispenser (F3) and Cup Dispenser (F4) with outward dimples at top (see Figure 15)

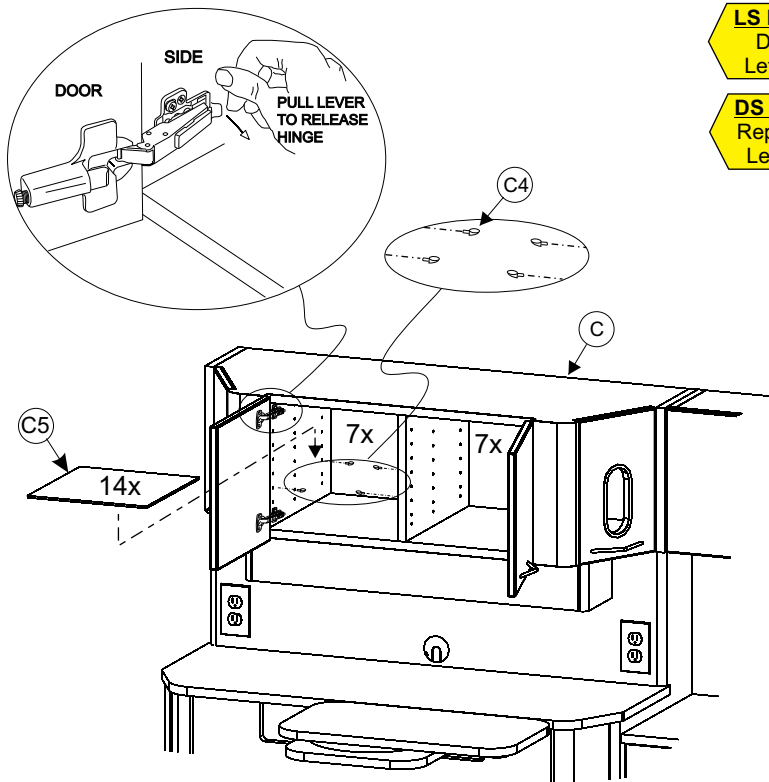

Figure 16

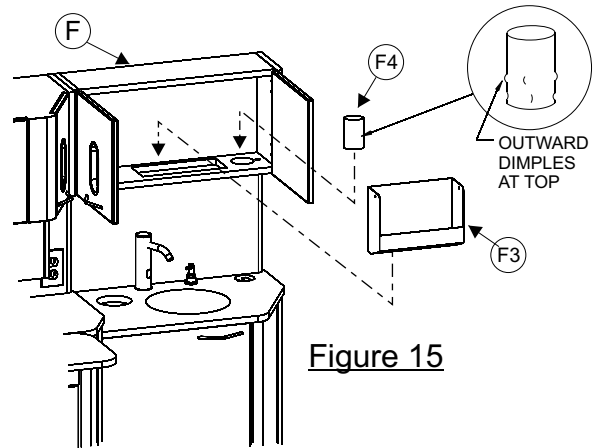

Figure 15

- RS Model**
As Shown
- LS Model**
Do at
Left End
- DS Model**
Repeat at
Left End

Step 17

Remove Upper Doors from Upper Storage (C) (to install Glass Shelves) by opening Upper Doors and pulling up on the tab at the end of the hinge base plate mounted on the inside of the storage area (see Figure 16).

Insert Glass Shelf Support Pins (C4) (4 for each shelf) into holes on the inside panels and then set Glass Shelves (C5) onto the support pins (see Figure 16). Place (7) shelves in each compartment.

Replace the doors by lining up the hinge and hinge plate then snap the hinge into place. See separate instruction page regarding adjusting the hinges if the doors are not properly aligned.

Assembly Instructions

Model: E-7-(DS,LS,RS)

Step 18

Open the Lower Cabinet (A) doors and reinstall the Bottom Cover (A2) in each door section (see Figure 17). You may need to tilt the bottom covers to remove from door opening.

Remount door handles from back side to front side on any doors with handles mounted on the inside face of the doors.

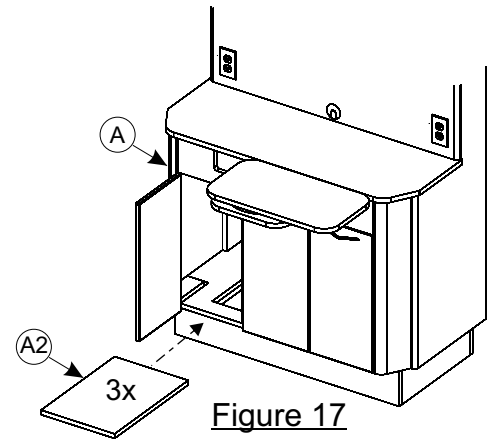

Figure 17

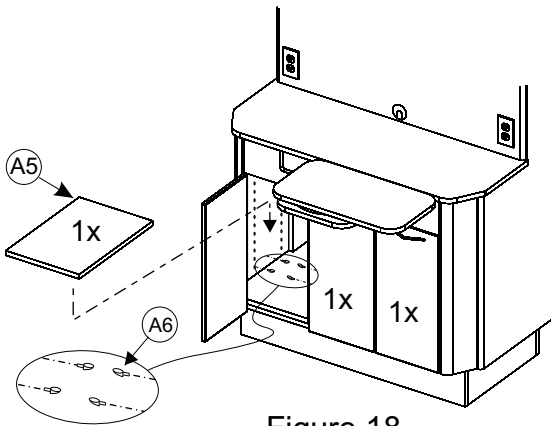

Figure 18

Step 19

Install Shelf Support Pins (A6) (4 for each shelf) into holes provided for the shelves and then set Shelves (A5) onto the support pins (see Figure 18). You may need to tilt the shelves to clear the door openings.

Step 20

Open the Sink Cabinet (D) door and reinstall the Bottom Cover (D1) (see Figure 19). You may need to tilt the bottom covers to remove from door opening.

Remount door handles from back side to front side on any doors with handles mounted on the inside face of the doors.

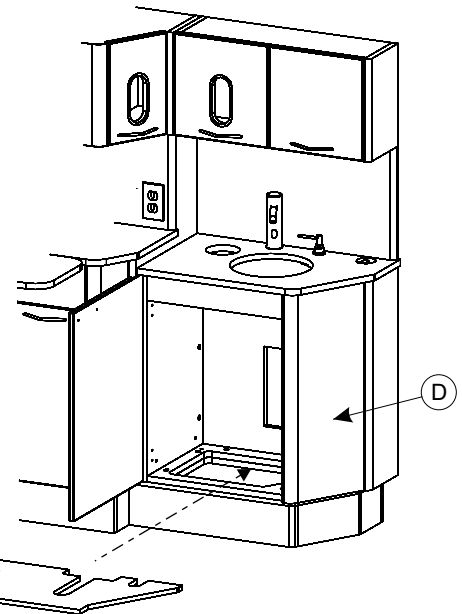

RS Model
As Shown

LS Model
Do at
Left End

DS Model
Repeat at
Left End

Installation Complete

Glass Bowl Installation

Model: E-7 w/ Glass Bowl Option

Step 1

Place Mounting Ring (A), Large Rubber Washer (B), Glass Bowl (C) aligned over the hole in the counter top. Insert the Drain Assembly (E) with the Small Rubber Washer (D) through the hole in the Glass Bowl. (see Figure 1).

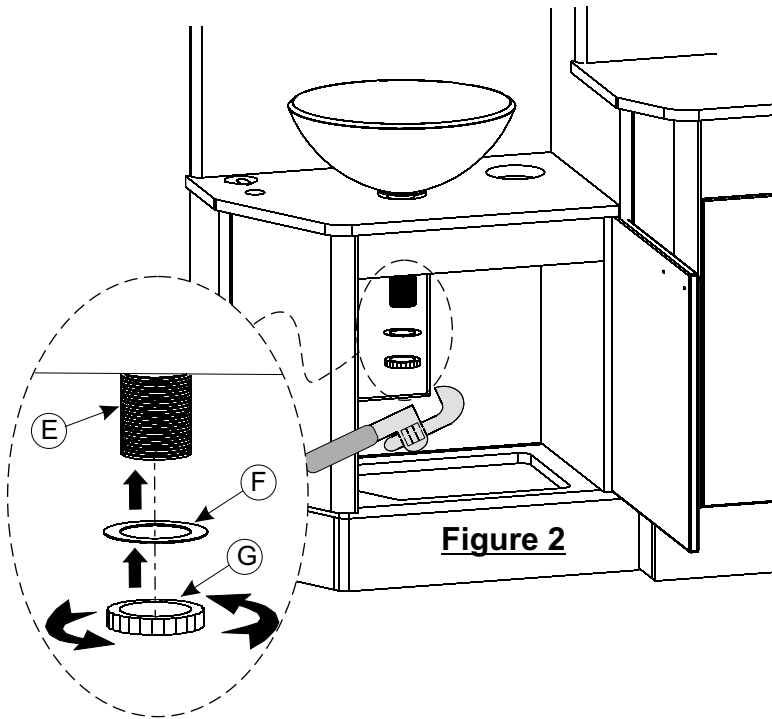
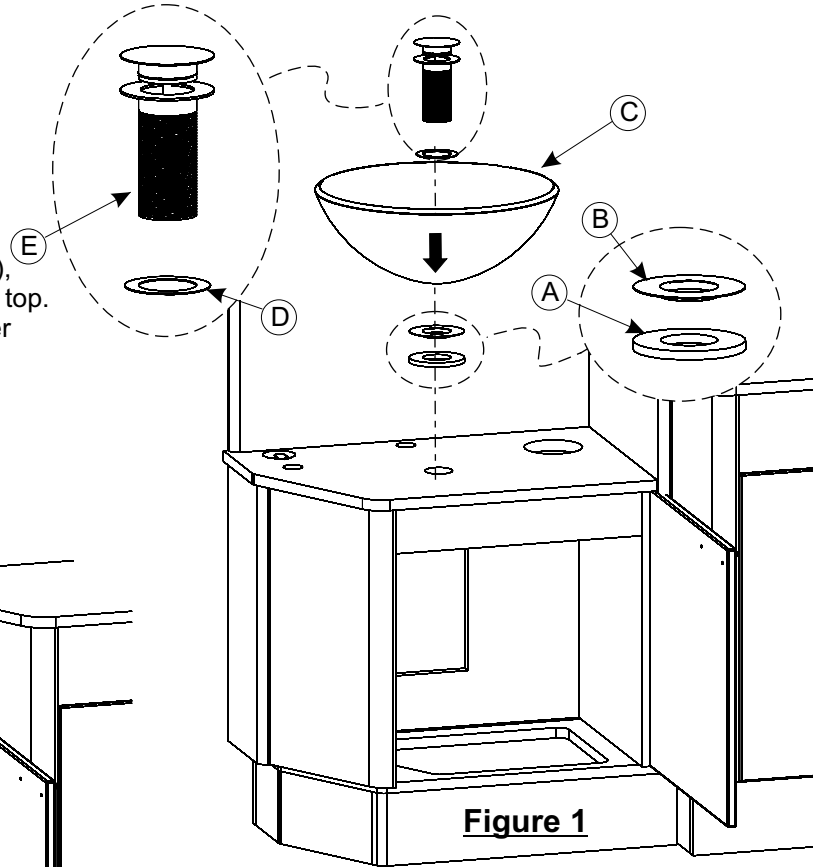

Step 2

Connect Drain Assembly Nut (G) to Drain Assembly (E) along with the Small Plastic Washer (F) and hand tighten to check for alignment then use pipe wrench to complete tightening (see Figure 2). CAUTION: DO NOT OVERTIGHTEN

Step 3

Connect Tail Piece (H) to Drain Assembly (E) and tighten using pipe wrench (see Figure 3). It may be necessary to cut off some of the Tail Piece to properly fit with remaining plumbing drain connections.

Make remaining plumbing drain connections per local codes and plumbing rough-ins.

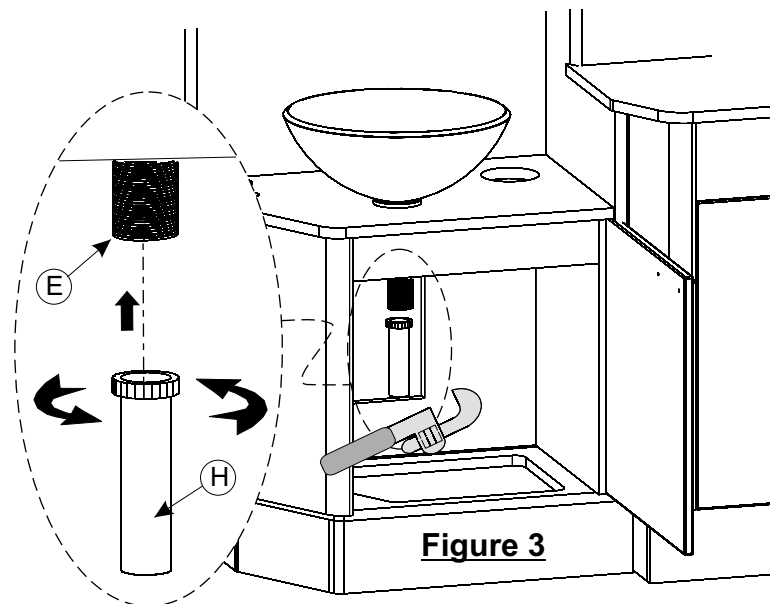

Water Bottle Mounting BDS-2561 / BDS-2563 Model: E-7-(DS,LS,RS)

Sliding Top Mount

See Figure 1

- Water bottle to be mounted to the underside of the sliding top. Align the center of the bottle with the center of the mounting bracket of the BDS-2561 / BDS-2563.
- Attach with (2) #10-24 x 3/4" screws.

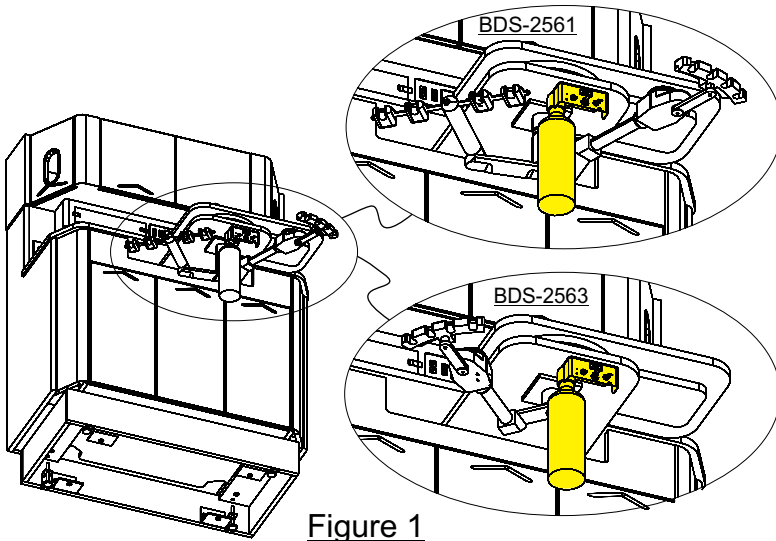

Figure 1

Side Mount (LS, RS Models Only)

See Figure 2

- Water bottle to be mounted to either side of the cabinetry.
- Note: This alternative requires the side mounting bracket.
- Drill 3/4" dia. hole thru the side of the cabinet directly below the bottom rear of the bracket. Attach with (2) #8 x 1-1/4" wood screws.

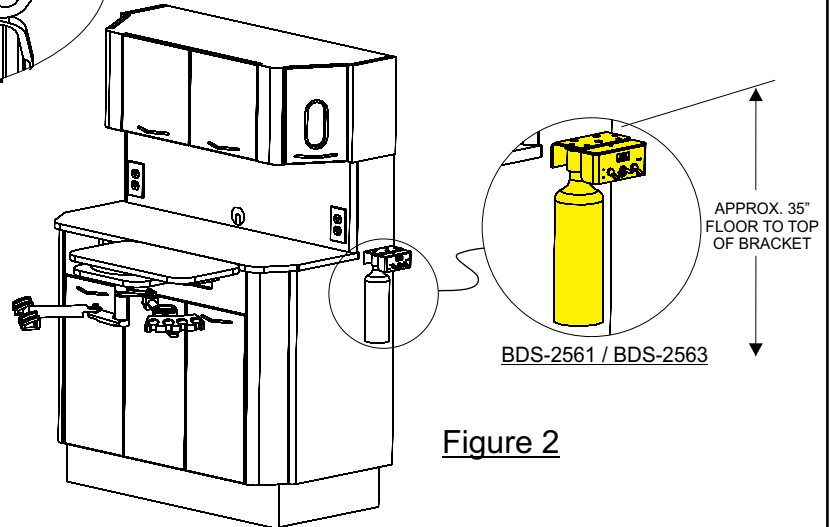

Figure 2

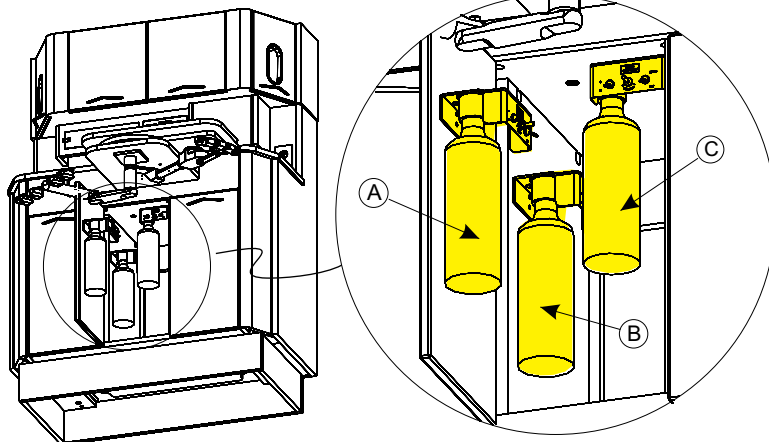

Figure 3

BDS-2561 / BDS-2563

Cabinet Interior Mount

See Figure 3

- Water bottle may be mounted to:
 - A - Interior face of center door
 - B - Center interior divider
 - C - Sub top
- Note: A & B alternatives require the side mounting bracket.
- Verify proper clearance/fit when closing door prior to securing with screws. Attach with (2) #8 x 3/4" wood screws.

Sink Cabinet Interior Mount

See Figure 4

- Water bottle may be mounted to:
 - A - Interior face of center door
 - B - Center interior divider
- Note: A & B alternatives require the side mounting bracket.
- Verify proper clearance/fit when closing door prior to securing with screws. Attach with (2) #8 x 3/4" wood screws.

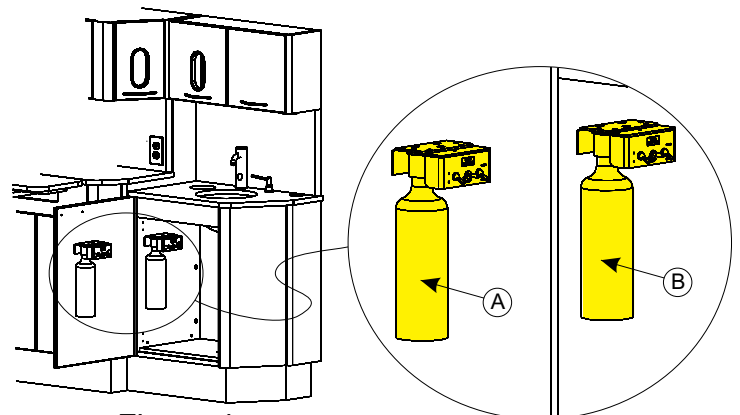

Figure 4

BDS-2561 / BDS-2563

Electrical Schematic

Model: E-7-LS

E-7-LS & E-7H-LS ELECTRICAL CONNECTIONS

WIRING SCHEMATIC

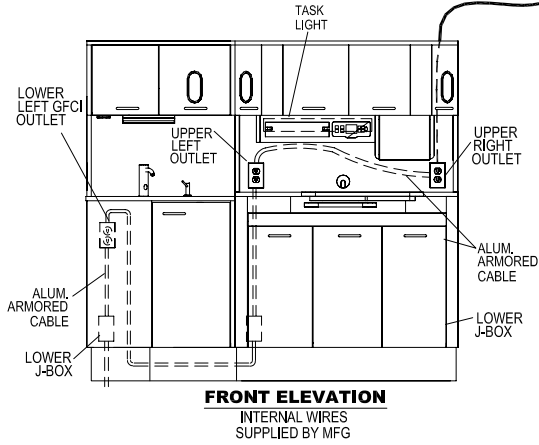
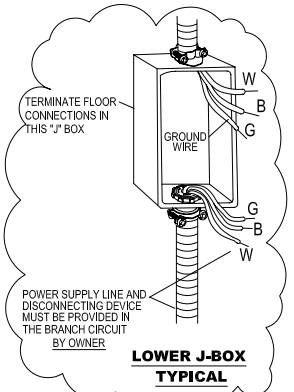
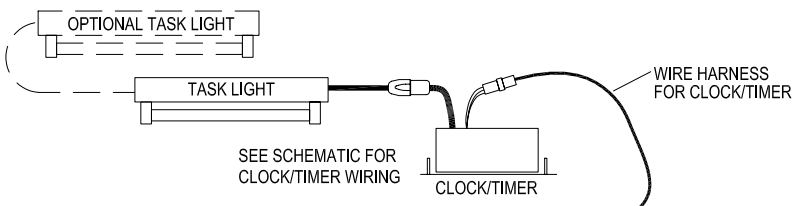
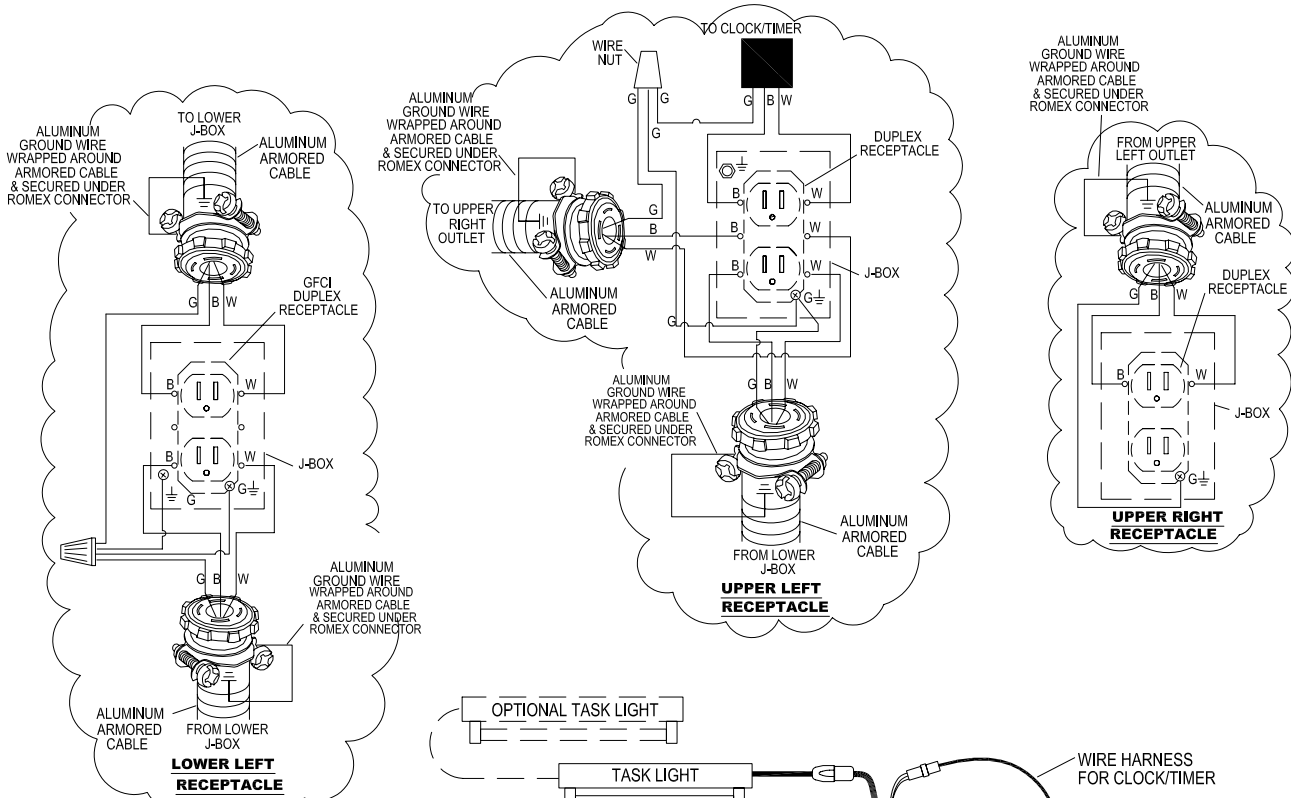
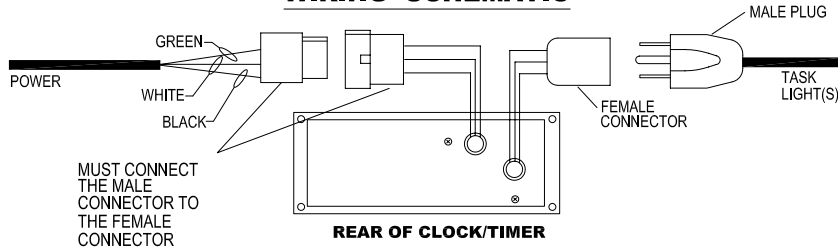

Electrical Schematic

Model: E-7-RS

E-7-RS & E-7H-RS ELECTRICAL CONNECTIONS

WIRING SCHEMATIC

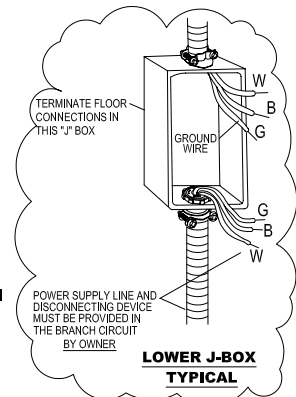
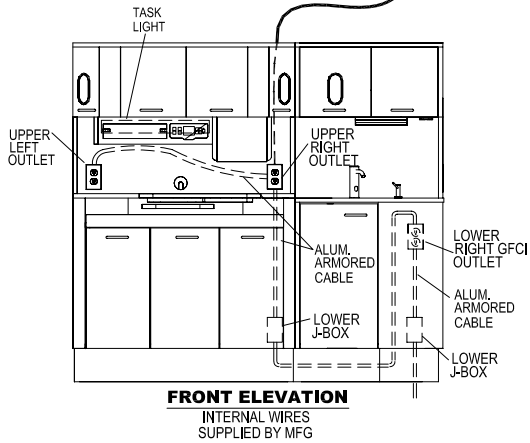
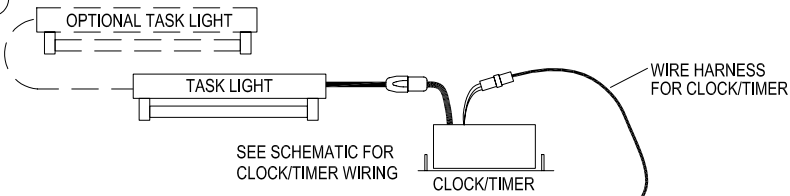
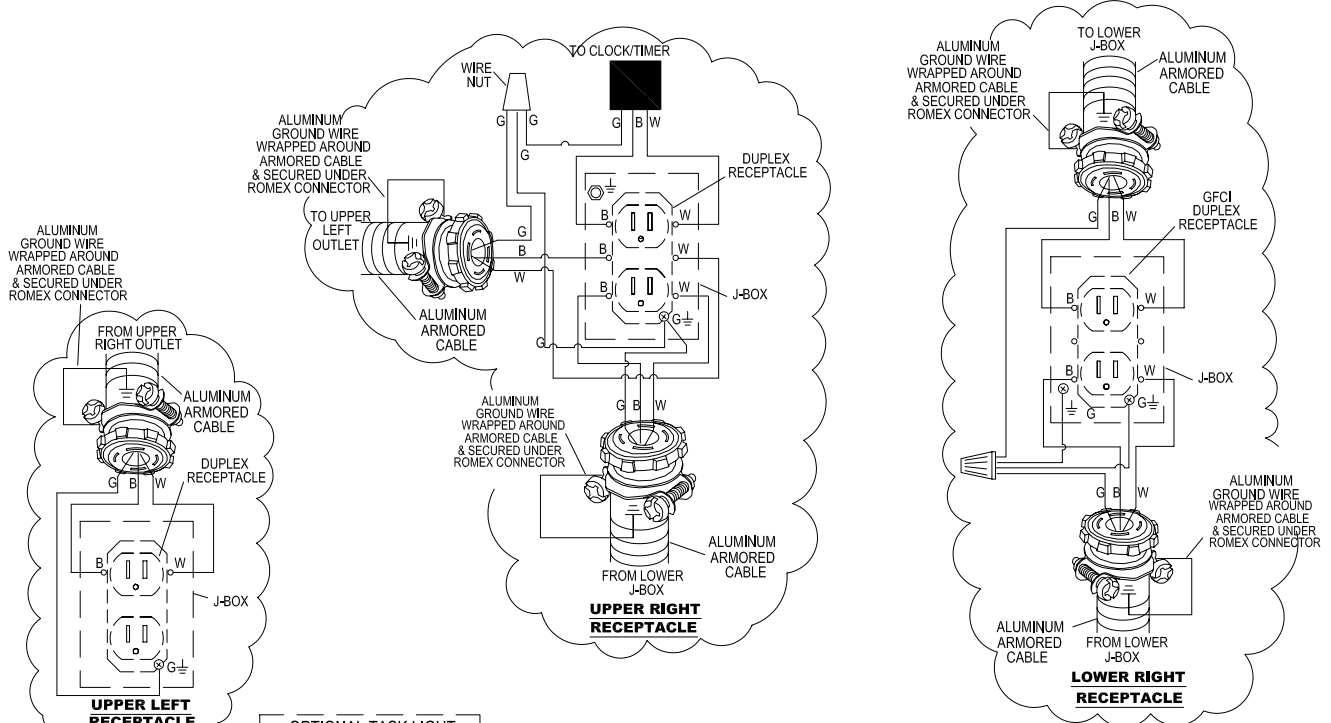
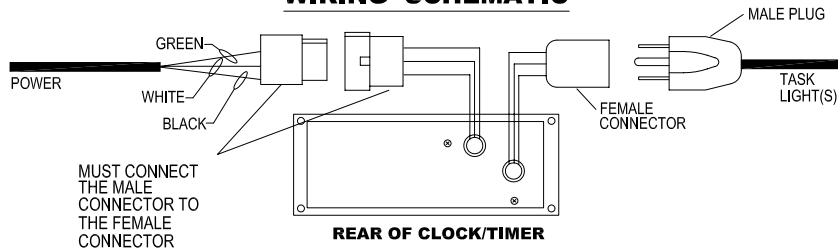

Clock / Timer Operation

Model: E-7-(DS,LS,RS)

Clock / Timer Operation

The top display is the Time-of-Day clock. The bottom display is the TIMER.

Normal operation:

The ON/OFF buttons are used to power the relay output for x-ray viewer and task light.

Press the SELECT button to select between TIMER1 and TIMER2.

Press the START button to start the time countdown.

At the end of countdown, the peep will sound for 5 seconds. The display will remain at 0:00 until the RESET button is pressed. Then, the TIME display is reset to the saved time.

While the timer is counting down, the display can be paused by pressing the RESET button once, then reset by pressing the RESET button again.

Setup:

When setting the Time-of-Day, the SELECT button is used to toggle between the HOURS or MINUTES digits of the TOD display. When setting the TIMER, the SELECT button is used to toggle between the MINUTES or SECONDS digits of the TIMER display.

To set the Time-of-Day clock display:

Press and hold the CLOCK button for 3 seconds. The peep will beep and the TIMER display will be OFF.

The lower decimal point of the colon is on to show that the HOURS digits are selected.

Use the UP or DOWN button to change the HOURS.

Press the SELECT button. The upper decimal point of the colon is on to show that the MINUTES digits are selected.

Use the UP or DOWN buttons to change the MINUTES.

Press the CLOCK button to save the Time-of-Day and return to normal operation.

Note: No button activity for 5 seconds will save and exit also.

To set the TIMER display:

Press the SELECT button to toggle between TIMER1 AND TIMER2.

Press and hold the TIMER button for 3 seconds. The peep will beep and the CLOCK display will be OFF.

The lower decimal point of the colon is on to show that the MINUTES digits are selected.

Use the UP or DOWN button to change the MINUTES.

Press the SELECT button. The upper decimal point of the colon is on to show that the SECONDS digits are selected.

Use the UP or DOWN buttons to change the SECONDS.

Press the TIMER button to save the TIME and return to normal operation.

Note: No button activity for 5 seconds will save and exit also.

Maximum TIME is 29 minutes, 59 seconds.



Electrical Parts List

Model: E-7-(DS,LS,RS)

Electrical Parts List

1. Junction box w/cover, galvanized steel. Overall dimensions, 4" long, 2 1/8" wide, 1 1/2" deep, .07" thick and 4" long, 4 1/4" wide, 1 1/2" deep .07" thick.. Secured to laminated particle board by screws. U.L. listed or equal.
2. #12-2 stranded aluminum armored cable U.L. listed or equal
3. Anti-short bushing size 0 for armored cable U.L. listed or equal.
4. 3/8" trade size, two screw connector U.L. listed or equal.
5. Conduit connector, 3/8" insulated. U.L. listed or equal.
6. Insulated spade tongue, for #12 Ga. AWG. U.L. listed or equal.
7. Wire connectors, (wire nut), screw on type. U.L. listed.
8. Receptacle, duplex 2-pole 3 wire grounding hospital grade, rated 125 VAC, 15 AMPS. U.L. listed or equal.
9. Wall plate, duplex, U.L. listed.
10. Fluorescent lamp assembly (E-7 & E-7G models only).
11. Clock/timer, see ETL control no. 3038374.

Electrical Specifications

Model: E-7-(DS,LS,RS)

Electrical Specifications

IMPORTANT NOTE: Approved electrical components and designs are used in the Quolis cabinet; however, the procedures described herein must be performed by a licensed electrician using approved methods and materials according to the local code governing the installation site.

General Electrical Notes

Each cabinet should be wired to a **SEPARATE 15 Amp circuit**.

Unless otherwise specified, **ALL WIRING** supplied by the contractor must be **APPROVED 12 Ga. AWG**.

Type B equipment providing a particular degree of protection against electric shock, particularly regarding: allowable leakage current, & reliability of the protective earth connection (if present).

Disconnect device must be provided in the branch circuit by electrician.

Hinge Adjustments

Model: E-7-(DS,LS,RS)

Hinge Adjustment For Standard Doors

Height

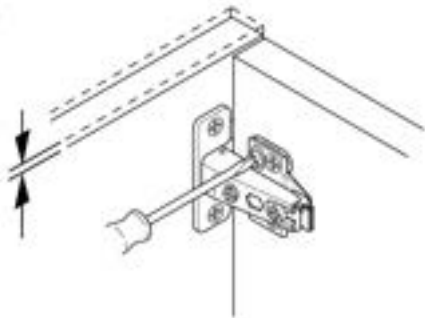

Side

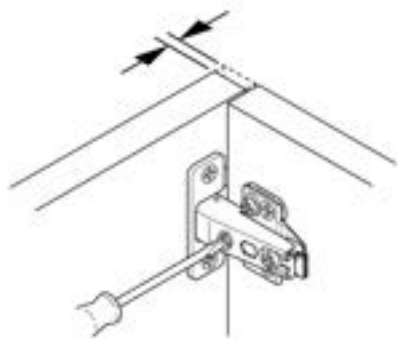

Depth

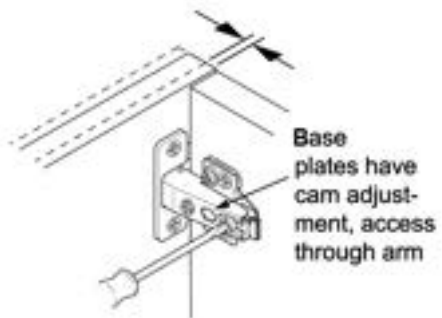

Hinge Adjustment For Angled Doors

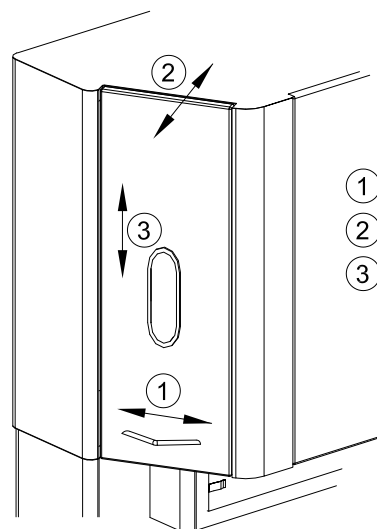
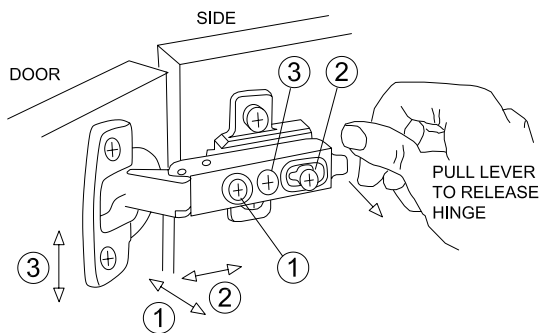

- ① Side Adjustment
- ② Depth Adjustment
- ③ Height Adjustment

G-Force™ Controlled Closing Device

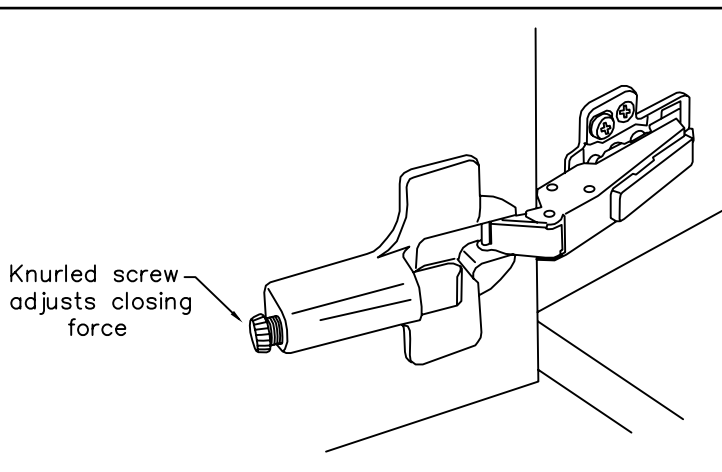

Drawer Assembly/Removal/Adjustments

Model: E-7-(DS,LS,RS) Option Only

Drawer insertion and removal

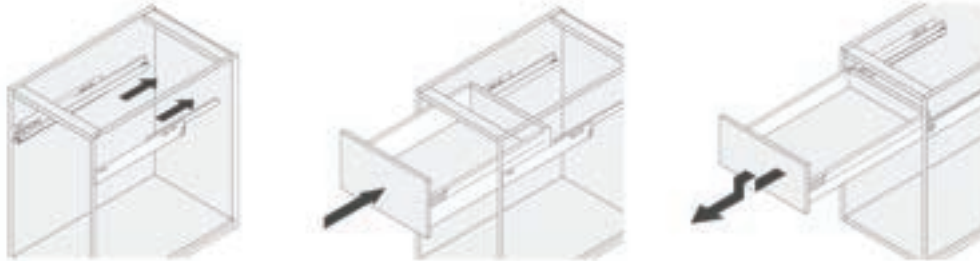

Drawer front attachment and removal

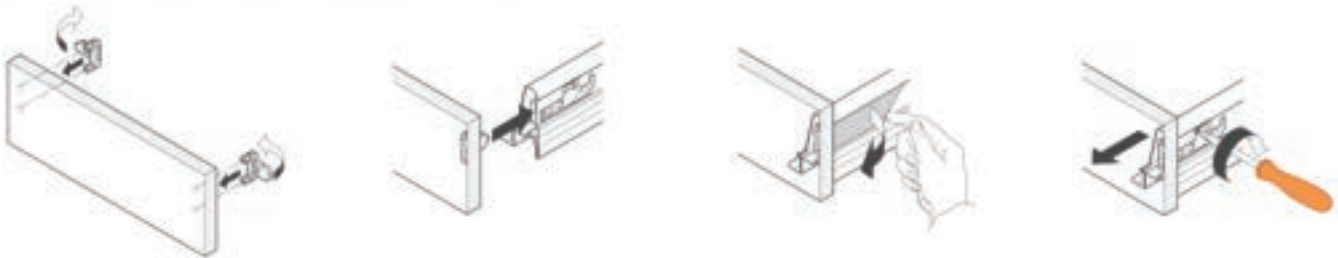

Drawer assembly

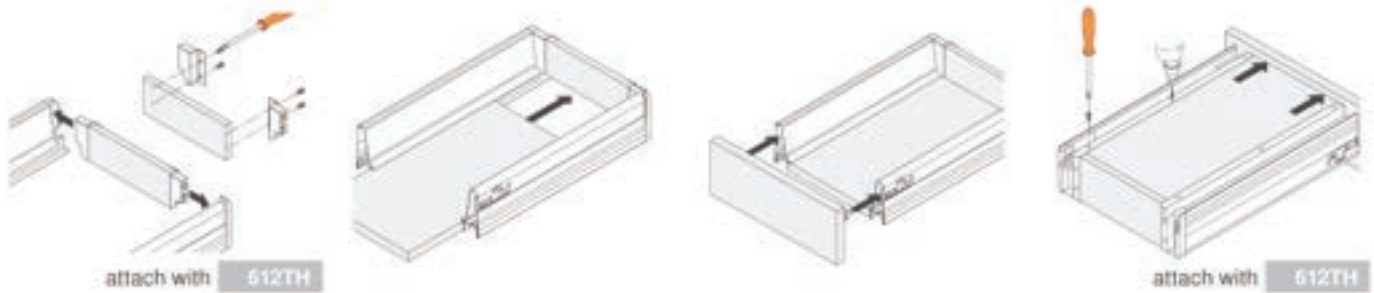

Side adjustment

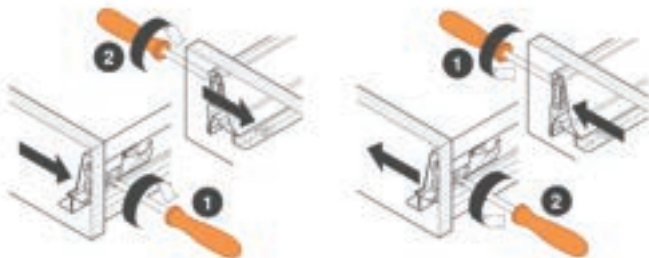

Cam height adjustment

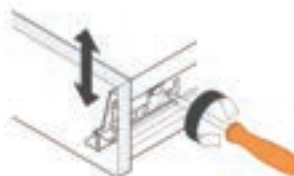

Floor Template Plumbing Details

Model: E-7-(DS,RS,LS)

LOOP VENTING (E-7-(DS,LS,RS))
IF LOOP VENTING IS REQUIRED AT
INSTALLATION SITE SEE THESE DIAGRAMS.

NOTE: VENT LOOP NOT APPLICABLE
FOR E-7G MODELS

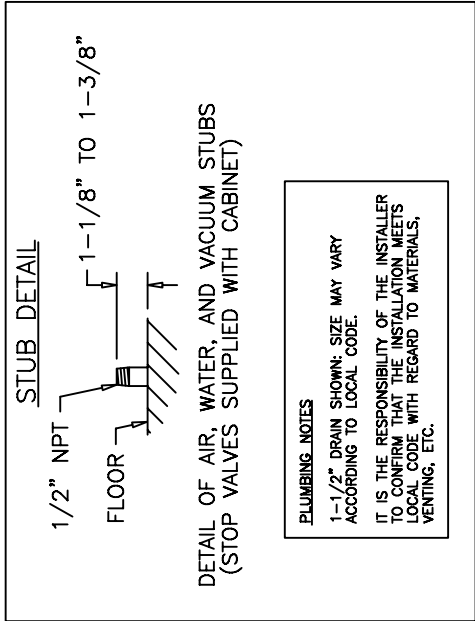
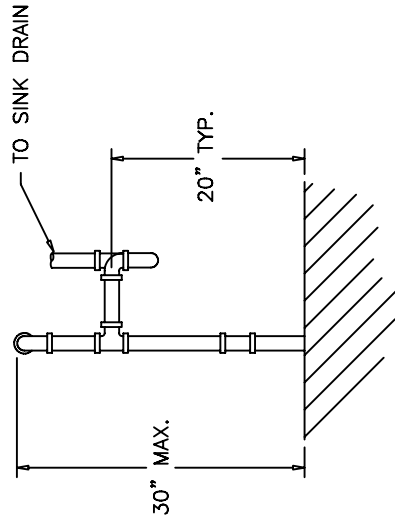
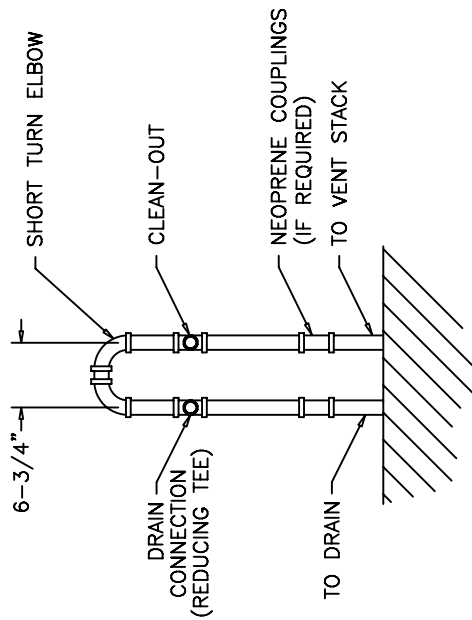
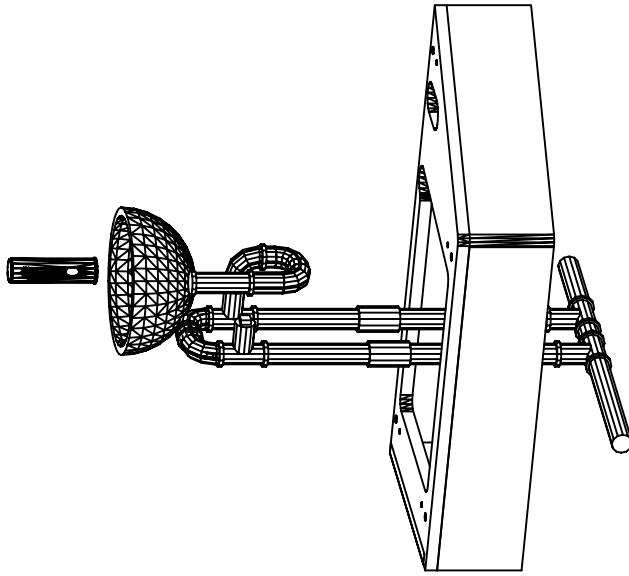

Wall Templates

Model: E-7-(LS,RS)

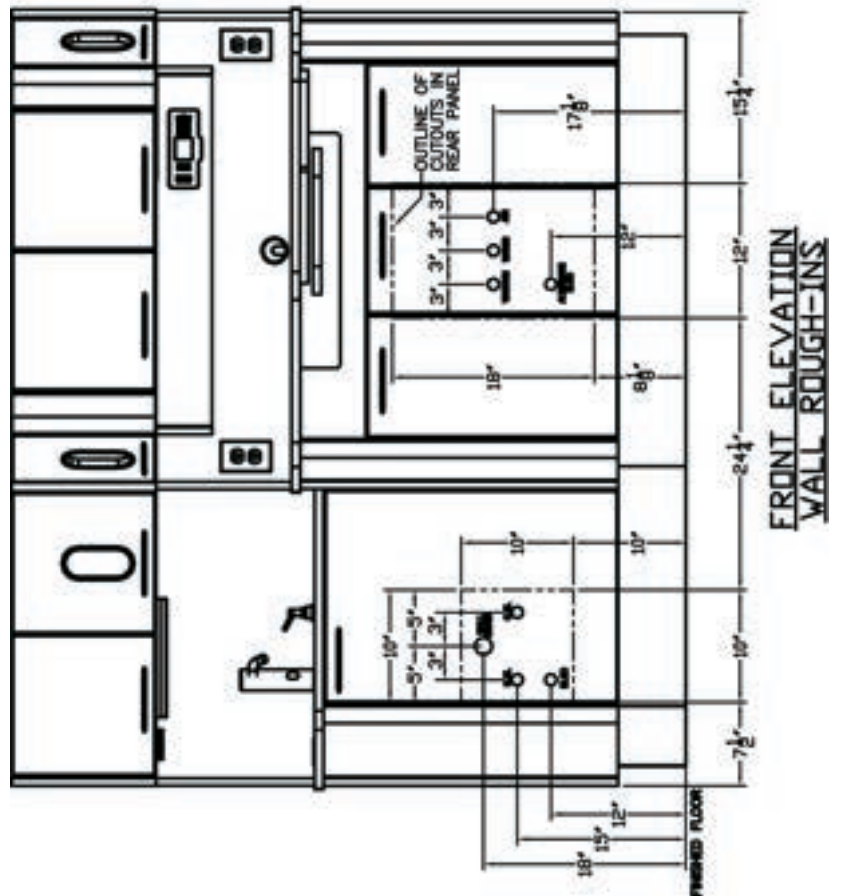
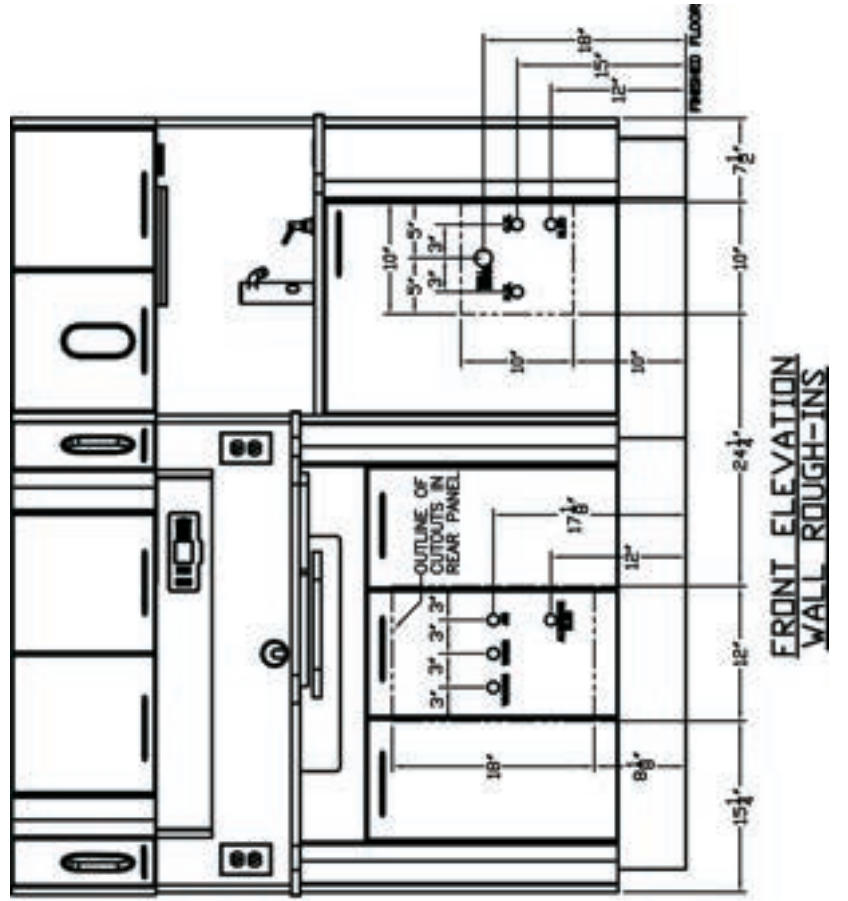

Floor Template

Model: E-7-DS

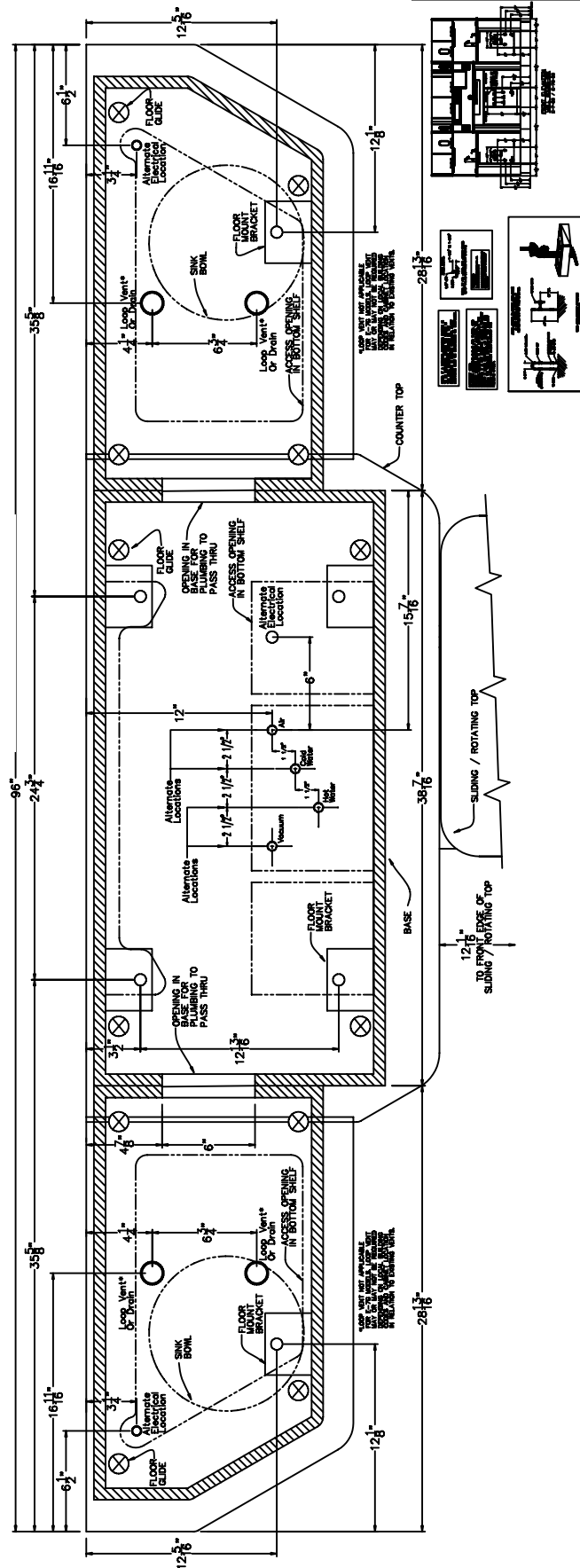

Floor Template

Model: E-7-RS

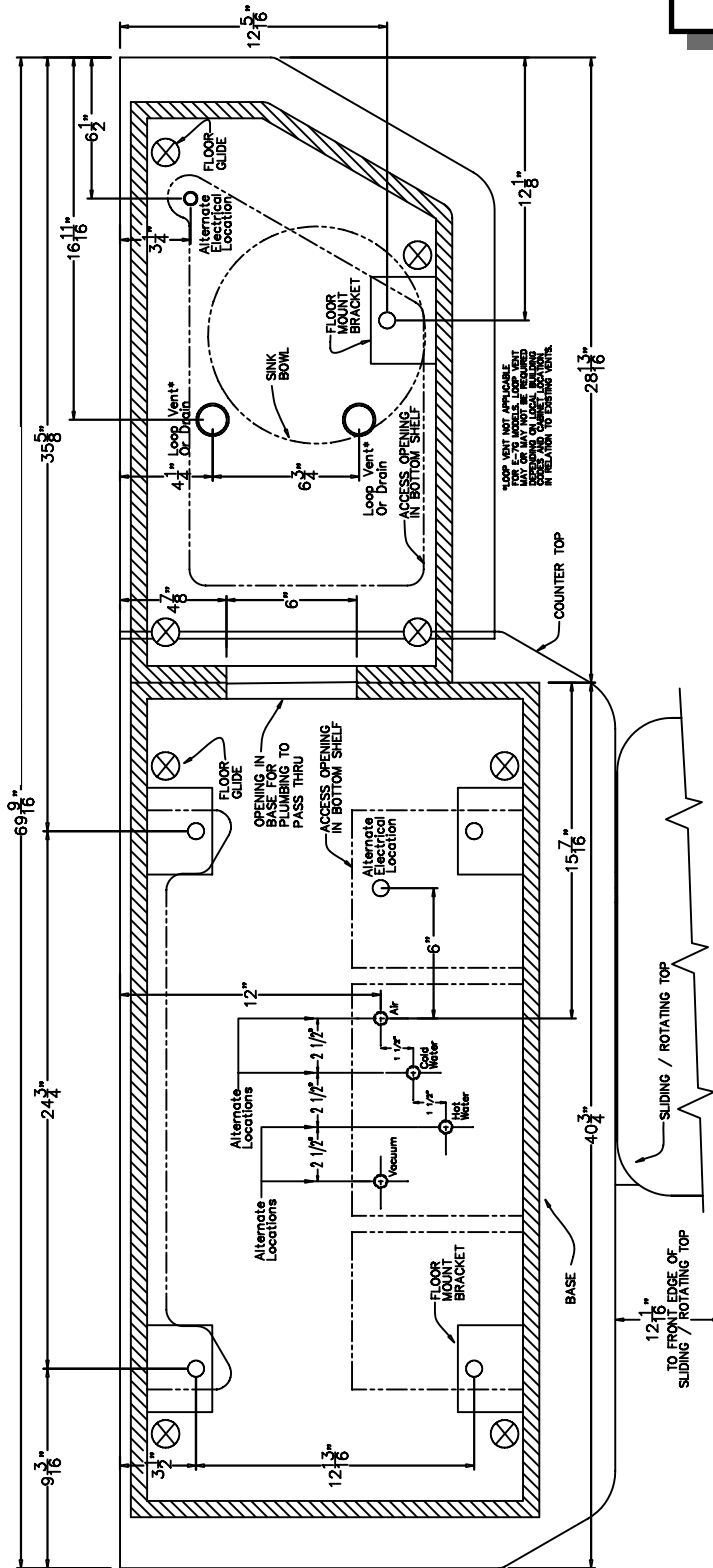

*SEE THE USER MANUAL FOR THE LOCATION OF THE LOOP VENT OR DRAIN. IT MUST BE LOCATED IN THE AREA TO BE DRAINED.

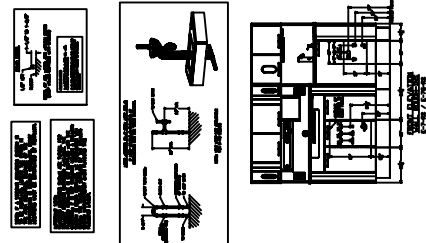

Surface Cleaning

Ortho-Sys. ECO-Sys, D-Series, & E-Series

Belmont Recommends:

- *Countertop Magic*® for Laminate and Solid Surface Work Surfaces
- *Stone Clean and Polish Magic*® for Cambria Quartz Work Surfaces
- *Cabinet and Wood Magic*® for Laminate and Melamine Surfaces
- *Stainless Steel Magic*® for Stainless Steel Surfaces

Products available at Lowes®, Home Depot®, or @ www.magicamerican.com

Laminate/Melamine Surfaces

Clean surfaces with a damp cloth or sponge with a mild soap.

Stains may be removed with most non-abrasive household cleaners such as Formula 409®, Fantastik®, Glass Plus®, or Windex with Ammonia D®.

For tough stains, use a paste of baking soda and water and apply with a soft bristled brush. Although baking soda is a low abrasive, excessive scrubbing or exerting too much force may damage the decorative surface.

Many commercially available products contain substances that may damage or discolor the decorative surface. **Do not** use abrasive cleaners such as toilet bowl cleaners, hydrogen peroxide, oven cleaners, drain cleaners, metal cleaners and polishes, chlorine bleach, coffee pot cleaners, hard water stain removers, fruit and berry juice, tub and tile cleaners, or equivalent.

LG HI-MACS® Solid Surface Tops

Clean surfaces with a damp cloth or sponge with a mild soap.

Stains can easily be removed using a domestic all-purpose cleaner or for tough stains use a bleaching agent (**do not leave in contact with the work surface for more than five minutes**) and rinse with clean water.

Avoid using cleaning agents that contain acids, such as methyl chloride or acetone. Should one of these products accidentally come into contact with the material, as a precautionary measure, rinse the surface with soapy water to prevent any discoloring taking place.

For additional care/maintenance, visit: www.lghausys.com

Cambria® Quartz Work Surfaces

Clean surfaces with a damp cloth or sponge with a mild soap.

Do not use abrasive, strong alkaline, acid, free radicals, or oxidized cleaners (whether high, neutral or low pH). **Do not** use products such as bleach, oven cleaners, Comet®, Soft Scrub®, SOS®, products with pumice, batteries, paint removers, furniture strippers, or tarnish/silver cleaners. **Do not** use abrasive or harsh scrub pads. **Do not** apply sealers, penetrants or topical treatments, as such products will wear off and cause the gloss to appear dull or inconsistent.

For additional care/maintenance, visit: www.cambriausa.com