

Evogue Chair (Model Q3300)
INSTALLATION INSTRUCTIONS

Safety Consideration

1 Risk Level Interpretation

Precautions before use

Make sure to carefully read the Safety Precautions and use the product correctly.

These precautions are intended to ensure the safe use of the product and prevent harm or damage to users or other people.

According to the magnitude of harm and damage and the degree of urgency, an incident that may be caused by misuse of the product is classified into one of the following categories: CONTRAINDICATION, WARNING, and CAUTION.

All of these categories are important for safety. Always follow the instructions provided.

We assume no responsibility for any accident due to failure to follow the Safety Precautions even in the event of harm or damage to users or other persons.

In such case, users or other persons who use the product without observing the Safety Precautions is responsible for any harm or damage incurred.

The graphical symbols are explained in detail below.

Once you have fully understood this explanation, read the text.

Classification by degree of harm or damage and urgency

CONTRAINDICATION

Use of the product without regard to this indication will create a hazardous condition that may result in death or serious injury.

WARNING

Improper handling of the product without regard to this indication will create a hazardous condition that may result in death or serious injury.

CAUTION

Improper handling of the product without regard to this indication will create a potentially hazardous condition that may result in moderate or slight injury or property damage.

The following graphical symbols are used to explain your responsibilities for using the product safely:

Graphical symbols for prohibited activity

 Generally prohibited activity

Graphical symbol for mandatory instructions

 Mandatory instructions for ordinary users

2 Safety Precautions

CONTRAINDICATION

Installing or transferring the product

Precautions regarding installation

Do not install the product near electromagnetic sources such as communication facilities or elevators.

Malfunction of this product may occur in the presence of electromagnetic interference waves.

WARNING

Installing or transferring the product

Precautions for installation

Make sure to place the product on a firm and flat floor.

Placing the equipment on a tilted floor may cause it to fall.

To avoid the risk of electric shock, this equipment must only be connected to a supply mains with protective earth.

Failure or electric leak may result in electric shock.

Installation

Precautions for operating the chair

Before and during the chair operation, pay close attention to the operation range (seat raising/lowering direction, backrest lowering/raising direction), and ensure that the chair does not contact any body parts, hands or feet, or objects. Body parts, hands or feet, or objects may become caught in the chair, causing injury or damage to peripheral devices.

CAUTION

Installation

Cautions on Installation Work

Metal or mechanical parts of this product may have sharp edges or corners. Be careful to avoid injury to your hands and fingers during installation work.

Cautions regarding installation

1 Guaranteeing safety of workers

1. The installation of this product and the connection of its supply connection part should be handled by a local authorized Belmont dealer.
2. Workers should wear work clothing that matches the operation, shoes (bare feet and sandals are strictly prohibited), and gloves for moving heavy objects.
3. Unless there are special reasons for operation, the supply of electricity, water, air and gas to the product should be shut down throughout operation.
4. To prevent the product from falling down, fix the chair on the floor before performing the assembly of unit parts, etc.

2 Precautions for installation

1. When moving the product, hold only the designated parts. Holding other sections may result in personal injury or damage to property.
2. Be sure to confirm that the retaining bolts are fixed before lifting up the chair.
3. Carry the equipment carefully in order to prevent its fall.
4. Do not let the product fall, crash into other objects, or apply strong shock to it.
5. Accurately undertake the rising process on the floor.
6. Be sure to remove dust in the source line before connecting the junction section.
7. Securely connect the water supply and drain hoses. Take deodorization measures for the drain hose.
8. Be sure to take fixation measures onto the floor.
9. Do not connect the power input to other than rated power supply.
10. Be sure to connect grounding.
11. Perform horizontal adjustment so that the table or light will not be dislocated.
12. After completing all processes, confirm that each section operates normally, and that there is no water leak or air leak, before putting on the cover.

3 Mobile communication devices

Mobile communication devices may affect electrical medical devices. Therefore, the use of mobile communication devices is prohibited in a medical office or hospital environment.

4 Repair

Never remodel this product.
For its repair, use parts designated by Takara Belmont.

Conditions for installation site

1 Conditions for installation site

1. The floor surface should be even and horizontal.
2. The floor strength of the building should be $\geq 4,900$ N/m².
3. As the floor material of the building, plywood with the thickness of 25 mm as recommended by Takara Belmont, or a composite material that combines plywood with the thickness of 15 mm and particle board with the thickness of 20 mm, should be used.
Alternatively, a floor material with the strength greater than the above should be used.
4. This product satisfies the EMC (electromagnetic compatibility) standards. However, it should not be used adjacent to, or stacked with, other equipment. If the product is to be used in proximity with other equipment, normal operation of the respective devices should be confirmed in the planned layout.
5. The product should be installed in a place that is not exposed to water.
6. The product should be installed in a place that will not be negatively affected by air pressure, temperature, humidity, ventilation, sunlight, dust, salt, sulfur content, and/or ozonic air (from an ozone generator).
7. Be careful about stability conditions, such as inclination, vibration and shock (including those during transport).
8. Do not install the product in a place where chemicals are stored or where gas is generated.
9. Be careful about the frequency and voltage of power supply, and about allowable ampacity, and connect grounding correctly.
10. To prevent water leaks, perform caulking securely in the penetrated section on the floor surface for riser piping.

2 Fixation on the floor

Concrete floor

Use anchor bolts with the diameter of 8 mm.

The anchor bolts should be 35mm or more in depth.

Wood floor

Use coach bolts enclosed in the product package.

WARNING

Unless the this product is fixed onto the floor, there is risk of fall of the equipment, which may result in serious injury or damage not only to workers engaged in the installation process, but also to equipment in the clinic, users, patients, etc.

Conditions for installation site

3 Capacity of power supply equipment to be used

- The power supply specifications of the installation site should be observed.
Rated voltage and power supply input for each Evogue Chair (Model Q3300) are following below.
The minimum capacity of power supply equipment should have 1,500 VA and over.

Rated voltage	AC120V
Power frequency	60Hz
Power supply input	4.2A

- Be sure to connect grounding.

Technical Data

Model	AC-Q33-CD36*
Classification for protection against electric shock	Class I Equipment
Classification according to the degree of protection against electric shock	Type B Applied
Rated voltage	Parts(chair upholstered parts / armrest)
Power frequency	AC120 V
Power input	60 Hz
Fuse	4.2 A
	Fuse holder
	10A / 250V
	(Interrupting capacity: 750A / 250VAC)
	Operating speed: Interrupting
	Size: 6.3 × 32 mm
	Chair control board
	1.25A / 250V
	(Interrupting capacity: 1500A / 250VAC)
	Operating speed: Interrupting
	Size: 5.2 × 20 mm
Operation mode	Non-continuous operation (motor)
	Maximum operating time, 3 minutes
	DUTY 1:15
Weight	293 lbs (133 kg)
Chair Initial height/stroke	15.7 / 15.7 inch
	(400 / 400 mm)
Chair raising and lowering mechanism	Electrohydraulic
Headrest	Manual
Backrest	Electrohydraulic
Seat	Backrest-linked tilt mechanism
Armrest	With rotation function on both sides
Upholstered parts	Synthetic leather
Operation switch	Backrest switch/Foot switch
Usage environment	Temperature 32 ~ 104°F (0 ~ 40°C)
	Humidity 10 ~ 95% (No condensation)
	Atmospheric pressure 10 ~ 15.4 psi
	(700 ~ 1060 hPa)
Transportation/storage environment	Temperature: -4-158°F (-20-70°C)
	Humidity: 10-95% (No condensation)
	Atmospheric pressure: 10-15.4psi
	(700-1,060 hPa)
Patient weight limit	440 lbs (200 kg)
Use in high-oxygen environments	The product is not suitable for use in a high-oxygen environment.

Refer to the rating plate for the capacity of power supply.

The specification is subject to change without notice.

Technical Data

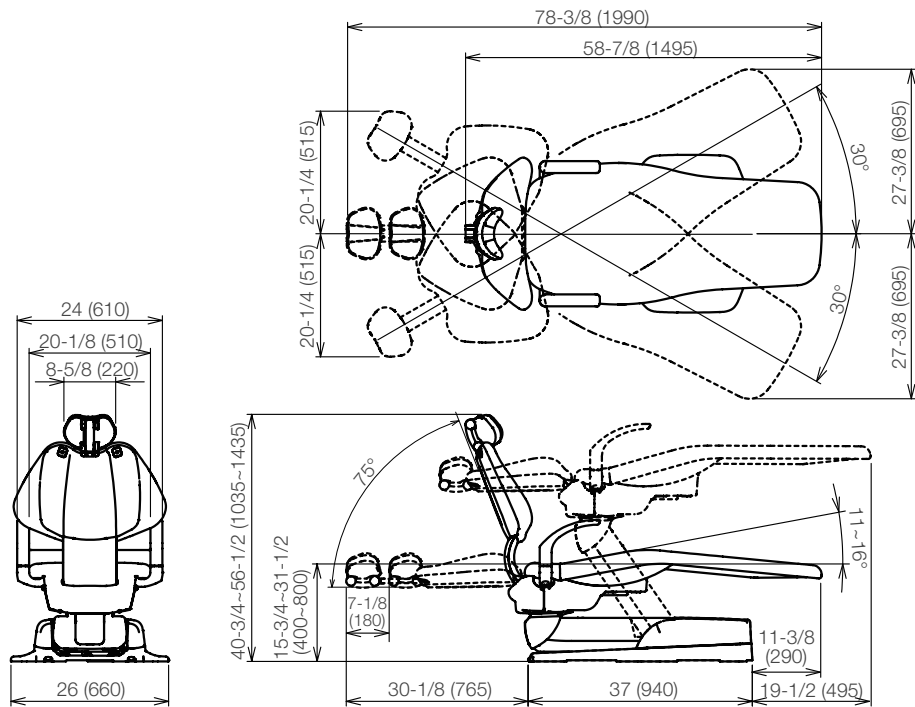

Unit : inch (mm)
Tolerance in dimensions: ±10%

The specification is subject to change without notice.

Installation

1 Necessary tools

No.	Tool name	QTY.
1	Phillips screwdriver No. 1-3	1 for each
2	6-piece double head open end wrench set (5.5-24 mm)	1
3	8-piece hex key wrench set (1.5-8 mm)	1

2 Supplied parts

Chair (unit)

No.	Part name	QTY.
1	Foot swith [for Canada]	1
2	Cable tie	1
3	Backrest unit	1
4	Backrest cover	1
5	Headrest cover	1
6	Armrest	2
7	Spring	2
8	Flat washer, M6 × 22 × 3, planed	2
9	Hole plug	1
10	Cap bolt, M8 × 20, planed	4
11	Truss screw M5×10, planed	6
12	Countersunk screw, M5 × 8, plated	3
13	Pan head screw 2P, M6 × 20, plated	2
14	Coach bolt, M9 × 65, plated	2

Chair (cover parts)

No.	Part name	QTY.
1	Backrest cushion	1
2	Headrest cushion	1
3	Seat	1

Installation

STEP1 : Unpackage the chair

- ① Remove the carton case from the skid.
- ② Unscrew 2 anchoring bolts that anchor the chair to the skid.
- ③ Take the chair off of the skid.

⚠ CAUTION

When lifting the chair, hold onto the carriage bar and armrest brackets.

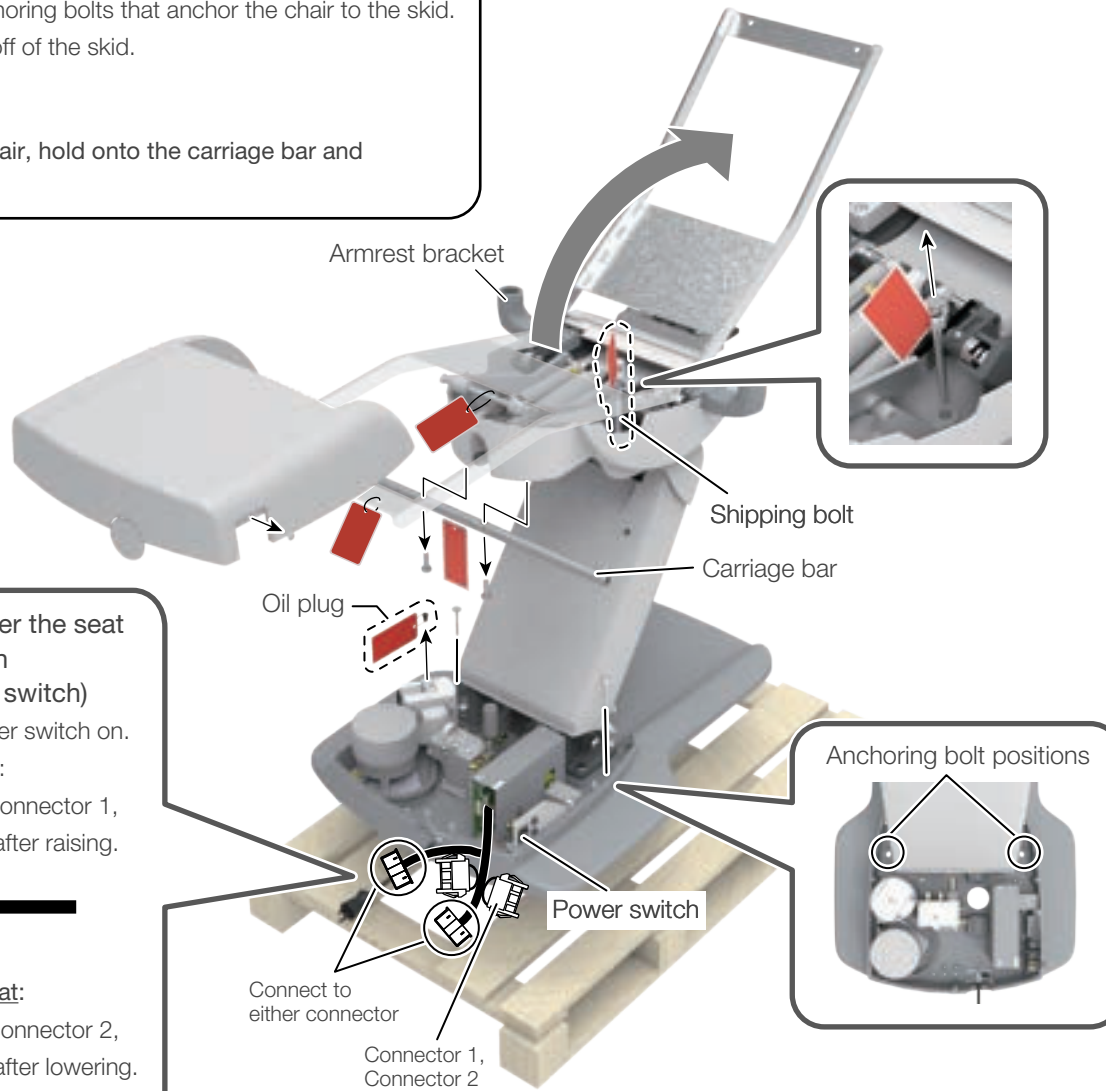

How to raise/lower the seat during installation (Without the foot switch)

1. Turn on the power switch on.

2. Raising the seat:

Connect to the connector 1, and disconnect after raising.



Lowering the seat:

Connect to the connector 2, and disconnect after lowering.



STEP2 : Remove shipping parts

- ④ Unscrew the shipping bolt.
- ⑤ Remove the oil plug from the oil reservoir.
- ⑥ Raise the seat and remove the carriage bar.
- ⑦ Remove all red tags.

⚠ CAUTION

Before raising the seat, confirm that the shipping bolt and oil plug are removed.

⚠ CAUTION

Do not lift the tilt bar. This may cause damage potentiometer link.

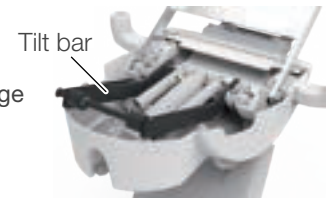

Installing the foot switch

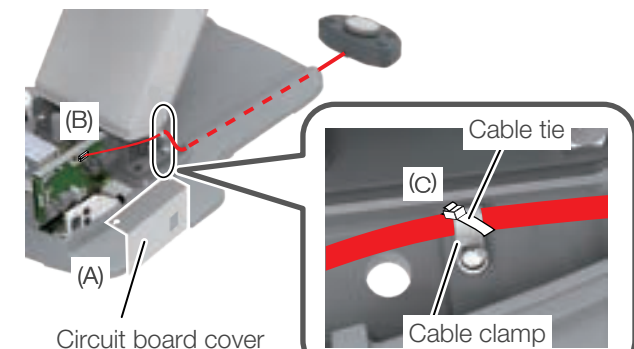

- (A) Remove the circuit board cover.
- (B) Route foot switch cable through the base from the rear side, and connect the cable connector to the circuit board connector labeled (CN2).
- (C) Secure the foot switch cable to the base by using the cable clamp, then hook the cable tie to the cable clamp, and fix the cable and cable clamp.

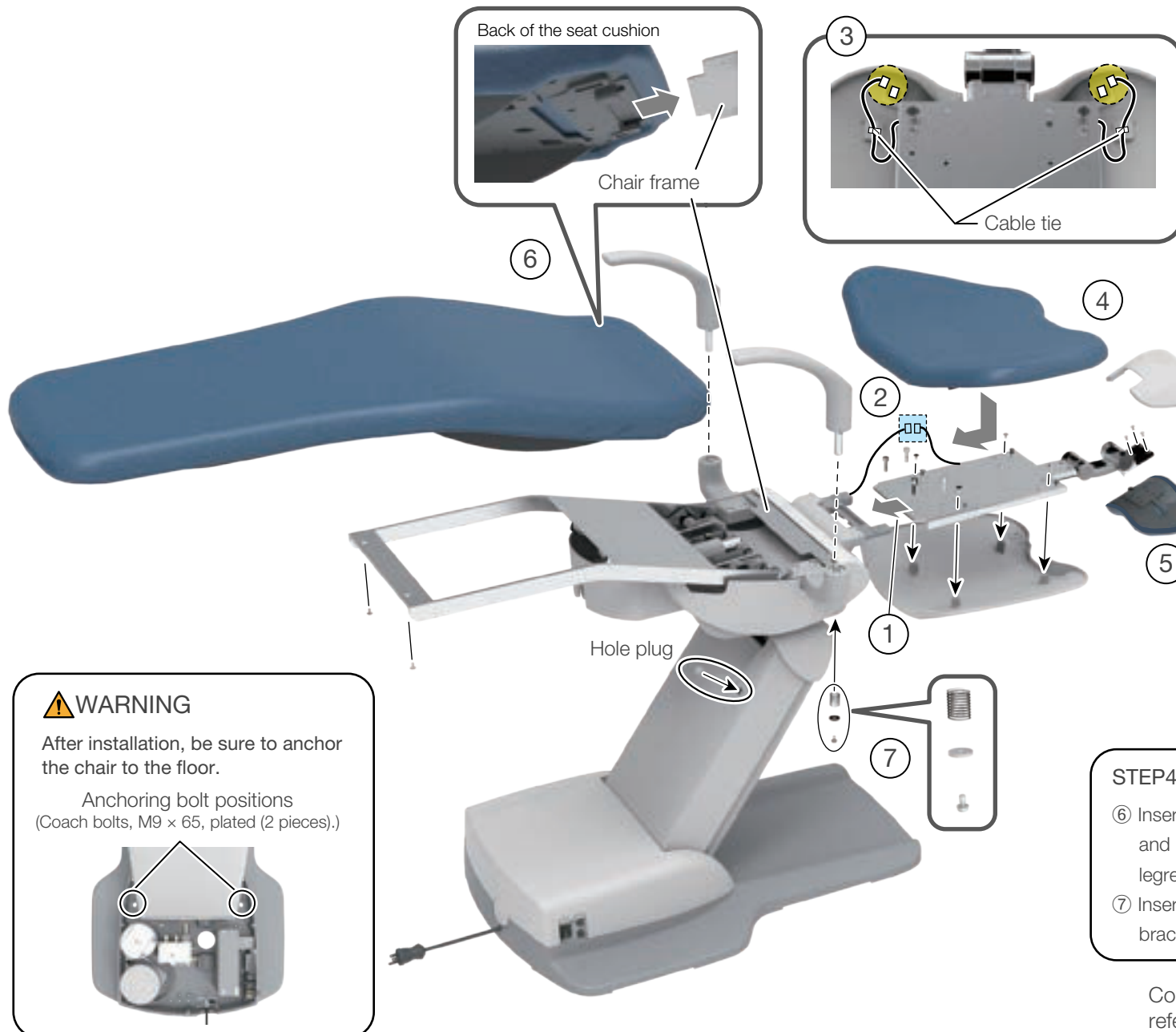

Installation



STEP3 : Attaching the backrest and headrest

- ① Attach the backrest plate assembly.
- ② Connect the backrest switch connector ( 1 place), then attach the backrest cover to the backrest plate assembly.
- ③ Connect the backrest cover switch connectors ( 2 places), then secure the cable with a cable tie.

The cable fits between the backrest plate assembly and the backrest cover.

- ④ Attach the backrest cushion to the backrest plate assembly. Insert the T-hooks through the 4 holes on the back of the backrest cushion, then slide the backrest cushion downward to lock.

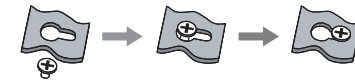

- ⑤ Attach the headrest cushion to the sliding headrest mechanism with 3 screws, then attach the headrest cover.

WARNING

After installation, be sure to anchor the chair to the floor.

Anchoring bolt positions
(Coach bolts, M9 × 65, plated (2 pieces).)

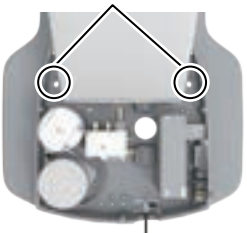

STEP4 : Attaching the seat cushion and armrests

- ⑥ Insert the back of the seat cushion into the chair frame, and lock it in place with 2 screws from underneath the legrest area.
- ⑦ Insert the armrests into armrest brackets. From underneath brackets, add springs, washers and screws as shown.

Concerning the dental unit to be attached to this chair, refer to the installation instructions for the unit.



Importer in U.S.A.
BELMONT EQUIPMENT,
Division of Takara Belmont USA, Inc.

101 Belmont Drive, Somerset, New Jersey 08873 U.S.A.
TEL.: (732) 469-5000 / (800) 223-1192
FAX.: (732) 356-1035

Importer in Canada
TAKARA COMPANY, CANADA, LTD.

2455 Meadowvale Blvd. Mississauga, Ontario L5N 5S2, Canada
TEL : (905) 816-8965
www.belmont.ca

BELMONT MANUFACTURING CO., LTD.
(Manufacturer)



Lot I-2, Long Duc Industrial Park, Long Duc Ward,
Long Thanh District, Dong Nai Province, Vietnam
TEL.: +84-2513-201-100 / FAX.: +84-2513-201-096

2022-02 (2nd Edition)	
REF	1E08DTBE