



Model Numbers:

EDS-0500 and EDS-0510

ECO-Sys

Delivery Systems

**Owner's Manual
and Installation
Instructions**



WARNING: PLEASE TAKE TIME OUT TO READ THROUGH THE FEATURES AND FAMILIARIZE YOUR SELF WITH THE UNIT. THIS UNIT SHOULD BE ASSEMBLED ONLY BY A QUALIFIED DENTAL EQUIPMENT TECHNICIAN.

For questions and general information, please contact us at:

Belmont Equipment
101 Belmont Drive
SOMERSET, NJ 08873

Watts: 800-223-1192 or Fax: 732-356-1035

060911

INDICATION FOR USE STATEMENT

Device Name: Belmont Series Dental Units

Indications For Use:

Belmont Series Delivery Units are intended to be used by Dentists, Hygienists, and Dental Assistants, or other licensed physician, or practitioner to supply power and utilities to, and serve as a base for, dental instruments and tools.

The serial numbers on your dental unit are found (1) under the delivery head and (2) inside the side mounted vacuum box.

Register them here for future use. _____

Warranty

Belmont Equipment is warranted from the manufacturer to be free from defective material and workmanship under normal use and service, for a period of two (2) years from date of shipment to the Buyer, except that any part or parts that are replaced under this Warranty within ninety (90) days of the completion of the two (2) year period shall be warranted to be free from defective material and workmanship for a period of ninety (90) days from date of shipment of said parts to Buyer. Belmont will repair or replace any defective part under this Warranty, provided the part is returned to our factory with prepaid postage, delivery or freight charges. In the event Warranty service must be performed to correct any defect, only Belmont and/or one of its authorized dealers shall provide same upon mutually agreeable arrangements made in advance.

Except as otherwise provided herein, there is NO WARRANTY, representation or condition of ANY KIND, express or implied (including NO WARRANTY OF MERCHANTABILITY OR FITNESS) and none shall be implied by law. THE EXPRESS WARRANTY AND THE REMEDIES CONTAINED HEREIN (1) ARE MADE SOLELY TO THE FIRST PURCHASER FOR BENEFICIAL USE (THE BUYER), (2) ARE THE SOLE WARRANTIES AND REMEDIES, (3) ARE IN LIEU OF ALL OTHER WARRANTIES, GUARANTEES, AGREEMENTS OR OTHER LIABILITIES, WHETHER EXPRESSED OR IMPLIED, AND ALL OTHER REMEDIES FOR BREACH OF WARRANTY OR ANY OTHER LIABILITY OF BELMONT. IN NO EVENT SHALL BELMONT BE LIABLE FOR CONSEQUENTIAL OR INCIDENTAL DAMAGES.

No person, agent, distributor or dealer is authorized to change, modify or extend the terms of the Warranty in any manner, whatsoever.

This Warranty is void when failure or defect is caused by conditions beyond the manufacturer's control, such as damage resulting from mishandling, neglect, misuse, improper maintenance, accident or alteration or repair by anyone other than Belmont or an authorized Belmont dealer.

Labor required to repair, replace or retrofit is not included during the warranty period by the manufacturer.

Please address any warranty or non-warranty service requests to your local dealer.

TABLE OF CONTENTS

Indications for Use	2
Warranty Policy	3
Installation Procedures	
Tools Required for Assembly	4
Symbols	5
Assembly Instructions	6-7
Utility Center	8
Cuspidor Assembly	9
Assistants Package	10
Flex arm Parallelism adjustment	10
Control Head	11
Operation and Control	
Delivery Head Operations and Controls	11
Tubing Color Guide	11
Troubleshooting Guide	
Delivery System Troubleshooting	12
Cuspidor System	13
Foot Control Troubleshooting	14-15
Foot Control Parts Breakdown	15
Syringe Installation / Parts Breakdown	16
Syringe Troubleshooting Guide	17
Diagrams & Schematics	
HVE/SE Care Maintenance and Sterilization	17
Delivery Head Control Schematic	18
Cuspidor schematic	18
Contamination Control System	19
Delivery Dimensions and Specifications	19

Tools required for Assembly

- Phillips screwdriver #2
- Snap Ring pliers
- Box knife
- 9/16" Box end wrench
- 5/32" Allen wrench
- 1/8" Allen wrench
- 3/32" Allen wrench
- Magnetic Bubble Levels

Symbol Definitions

 **DANGER**
A **DANGER** is used for an imminently hazardous operating procedure, practice or condition which, if not correctly followed, can result in loss of life or serious personal injury.

 **WARNING**
A **WARNING** is used for a potentially hazardous operating procedure, practice or condition which, if not correctly followed, can result in loss of life or serious personal injury.

 **CAUTION**
A **CAUTION** is used for a potentially hazardous operating procedure, practice or condition which, if not correctly followed, could result in minor or moderate injury. It may also be used to alert against unsafe practices.

 **EQUIPMENT ALERT**
An **EQUIPMENT ALERT** is used for an imminently or potentially hazardous operating procedure, practice or condition which, if not correctly followed, will or could result in serious, moderate or minor damage to unit.



High Voltage, *Haute tension*



Ground, *Mise à la Terre*



Fuse Rating Specs, *Spécifications du fusible*



Shipping Orientation, *Orientation du colis pour l'expédition*



Fragile, *Fragile*



Storage Range, *Plage ou T° d'emmagasinage*



Keep Dry, *Garder au Sec*



Exercise Mode, *Mode d'utilisation*





Hot Surface, *Surface chaude*





Type B Applied Part, *Dactylographiez la partie appliquée par B*

Définitions des symboles

 **DANGER**
DANGER est utilisé dans le cas d'une procédure hasardeuse éminente, une condition d'opération ou une pratique qui, si elle n'est pas respectée, peut résulter en la perte de vie humaine ou engendrer des blessures corporelles graves.

 **AVERTISSEMENT**
AVERTISSEMENT est utilisé pour signaler une procédure potentiellement dangereuse, une condition d'opération ou une pratique qui, si elle n'est pas respectée, peut résulter en la perte de vie humaine ou engendrer des blessures corporelles graves.

 **PRUDENCE**
PRUDENCE est utilisé pour signaler une procédure potentiellement dangereuse, une condition d'opération ou une pratique qui, si elle n'est pas respectée, peut provoquer des blessures corporelles mineures. Peut être utilisé également pour signaler des pratiques hors normes ou non sécuritaires.

 **ÉQUIPEMENT ALERTE**
ÉQUIPEMENT ALERTE est utilisé pour signaler une procédure hasardeuse éminente ou potentiellement dangereuse, une condition d'opération ou une pratique qui, si elle n'est pas respectée, va ou pourrait causer des dommages sérieux, modérés ou mineurs à l'appareil (équipement).



Self-contained Water, *Source d'eau Indépendante*



Municipal Water, *Eau municipale*



Cup Fill, *Distributeur d'eau pour gobelet*



Bowl Flush, *Source d'eau temporisée pour*



petit lavabo



Drive Air, *Source d'air*



Coolant Air Flow Control, *Contrôle de flux d'air pour refroidissement*

Assembly Instructions



- 1) Lay the cuspidor box on its side on the plastic bag it is packed in or on its box.
- 2) Remove the CV canister lid and push the plastic top cover housing up over the lip of the CV canister. If 0500 Cuspidor, also push Cuspidor up from the top cover. Remove the side cover panel (4 screws).
- 3) Remove the clamp by removing the two bolts holding the clamp as shown.



- 4) Insert the smaller pole (16") into the slot on the left. It should be even with the box at the bottom.
- 5) Insert the 45" light pole in the center slot with approximately 3 inches protruding from the bottom of the box.
- 6) Replace the clamp over the poles, tighten the center bolt first and then the bolt on the right. Tighten the set screws around the poles.
- 7) Insert the vacuum box assembly onto the chair adaptor and level using the 6 set screws on the adaptor collar.



EQUIPMENT ALERT

It is very important to completely remove the clamp from the vacuum box assembly before inserting poles. **Do not** slide the poles in their slots.

Failure to remove clamp will result in scratching of the powder-coat.

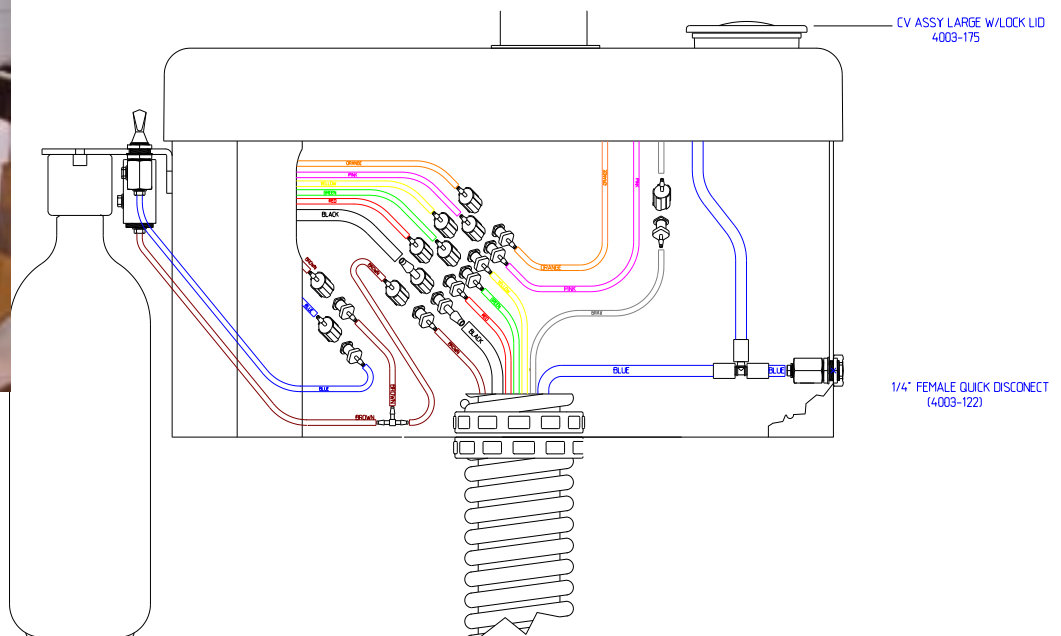

Diagram-C

**CAUTION**

The flex arm is wrapped under spring pressure. Personal injury can occur if care is not used when cutting the wrap holding it in place.

- 8) Install the two round trim rings over the tops of the poles. Insert the tubing bundle and Flex arm into the top of the smaller pole (16") and out the side slot near its base. Cut the plastic and paper wraps that secure the flex arm. Connect the tubing from the flex arm to the matching color of tubing coming from the 2" umbilical tube located in the cuspidor/assistant box. (See Diagram C) **Note: when preparing to twist the luers together turn them counter clockwise or in the opposite direction before twisting them together to avoid the spring reaction of the tubes causing them to disconnect.**

- 9) On the unattached end of the umbilical, slide the large spiral flex tubing into the appropriate slot in the junction box. Connect all the tubing according to the tubing diagram. (See Diagram D) **Note: when preparing to twist the luers together turn them counter clockwise or in the opposite direction before twisting them together to avoid the spring reaction of the tubes causing them to disconnect.**

- 10) Install the foot control tubing and make the necessary connections according to the diagram. (See Diagram D/1)

- 11) If a contoured cuspidor (EDS-0500) is part of this delivery system, spread grease around the inside of the cuspidor bowl socket. Press fit the Cup fill and Bowl flush spouts into their respective holes in the cuspidor bowl. Attach the 1/4" tube to the Bowl flush barb, and the 1/8" tube to the Cup fill barb. Press the cuspidor bowl snugly into the gray bowl socket on the cuspidor support assembly, taking care not to roll the O-rings out of their slots.

- 12) After securing bowl in cuspidor bowl socket: use a #2 phillips screw driver (with at least a 4" shank) and locate the 2 holes under the cuspidor bowl housing. Insert screw driver to tighten the 10-32 well nut screws. (see diagram on page 9) Failure to tighten screws will result in an unsecured cuspidor bowl which may result in leaking.

- 13) Reinstall the solids collector lid. Install the 2 instrument holders onto the vacuum instrumentation bracket, tighten the 10-32 set screws with a 3/32" Allen wrench. Hang the HVE and saliva ejector into the egg holders. Reinstall the cuspidor box side panel using the 4 screws that were removed earlier.

NOTE: Cuspidor Bowl Must be leveled in order to drain properly. Check using a bubble level.

Utility Center Tubing Diagram

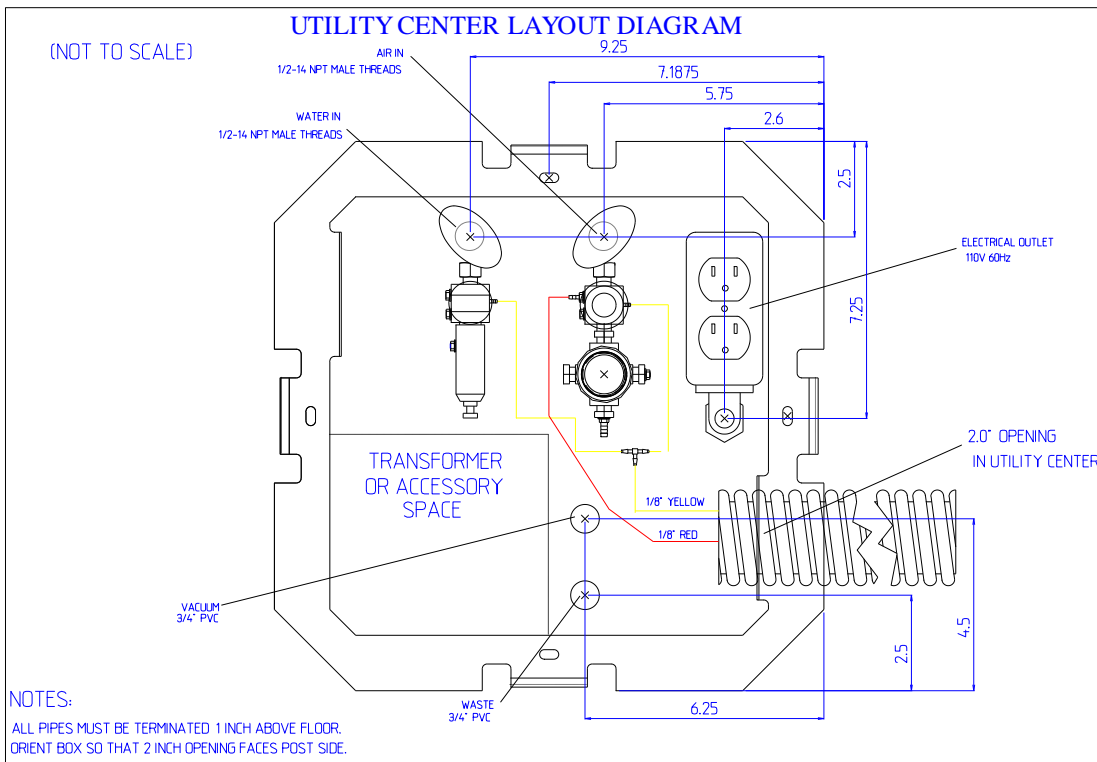
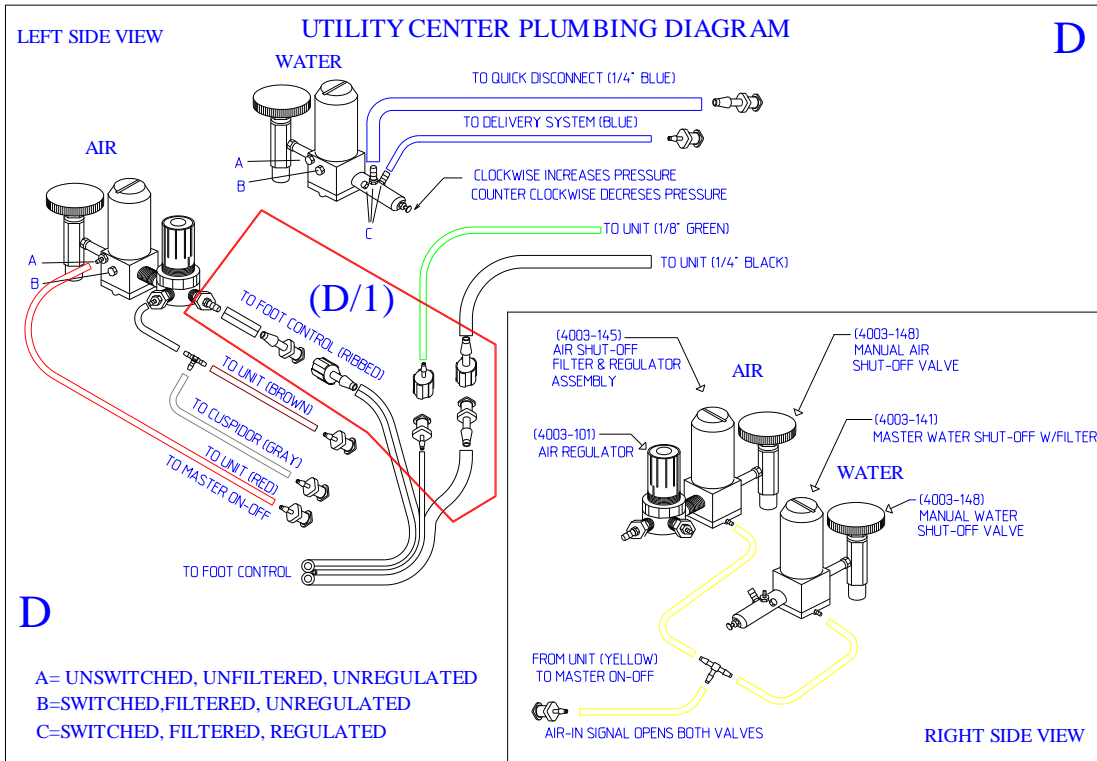

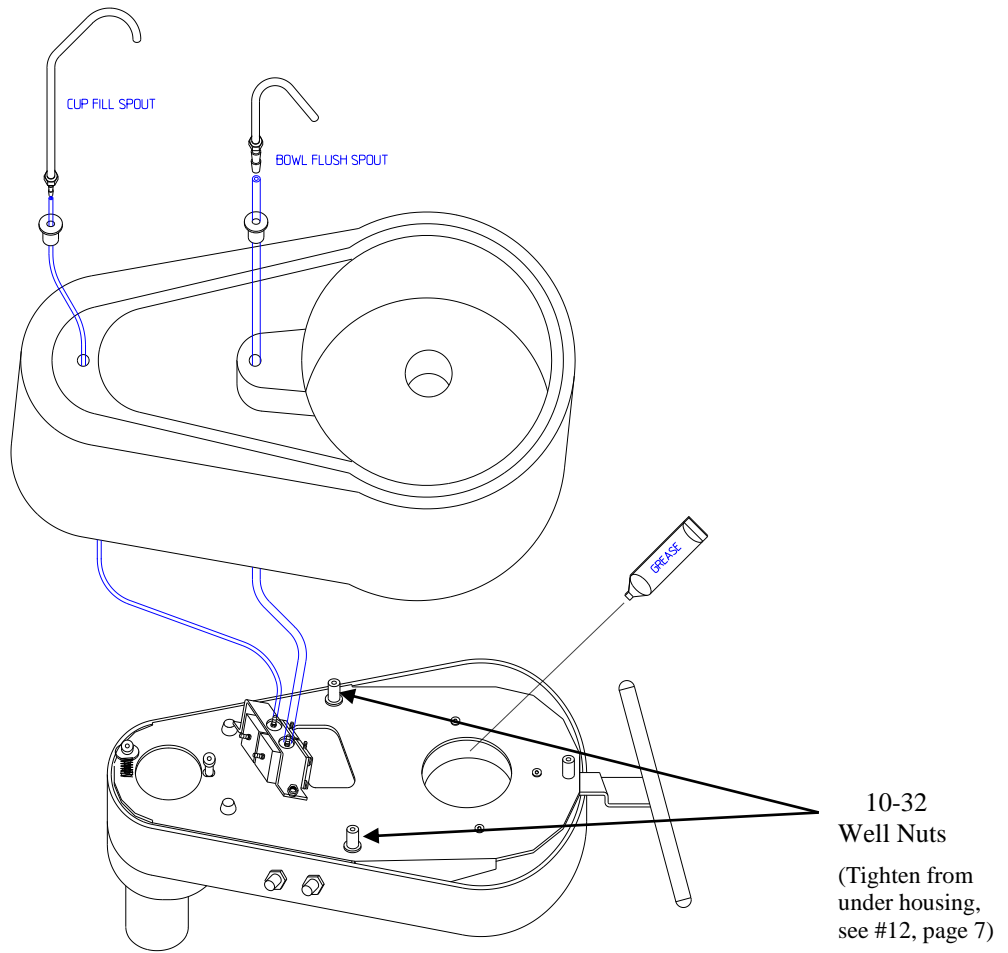

14) If this is an assistant's package (EDS-0510), push the plastic top cover housing back down over the lip of the solids collector canister. Reinstall the solids collector lid. Remove the 2 socket head cap screws from the post mount clamp bracket, separate the 2 sections of the bracket. Locate the bracket on the 16" post at an approximate 90-degree angle to the assistant's box. Tighten the 2 socket screws on the bracket. Install the 2 instrument holders onto the assistant's arm, fasten the 10-32 set screw with a 3/32" Allen wrench. Hang the HVE and saliva ejector into their holders. Reinstall the assistant's box side panel using the 4 screws that were removed earlier.

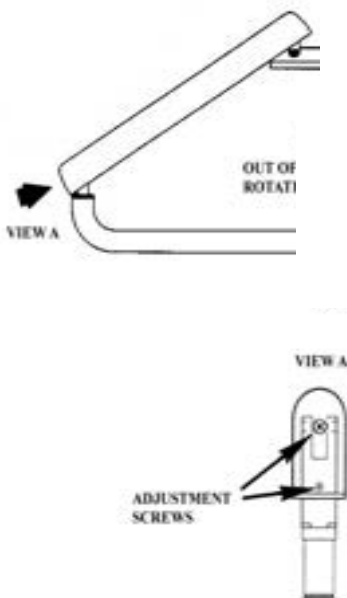

CAMBER AND TENSION ADJUSTMENT

The delivery head on the flexible arm should travel in a parallel plane to the floor, if not, the camber may need to be adjusted.

Initially, two checkouts should be performed (adjustment of the flexible arm may not be the problem).

- Check chair post for vertical alignment (plumb). If not level, adjust as necessary.
- Check the delivery system head for level. Adjust if necessary using shims (4 set screws in control mount)
- Check that arm does not rise or fall on its own from its set position. Adjust tension as necessary.

To adjust travel of the flexible arm in a parallel plane:

- 1) Remove plastic end cap from the arm.
- 2) Turn vertical adjustment screw with a 1/8" allen wrench clockwise to lower or counter-clockwise to raise until delivery system travels in a plane parallel to the floor.
- 3) Adjust the tension by turning the adjustment screw shown in View A with a 1/2" socket wrench with extension. Clockwise to increase tension, counter-clockwise to decrease tension
- 4) Replace plastic end cap. Delivery system head may need to be re-leveled (see leveling instruction above).

You have completed the Belmont ECO-Sys Delivery installation. Thank you for purchasing one of the most reliable delivery systems made today.

Delivery Head Operation and Controls

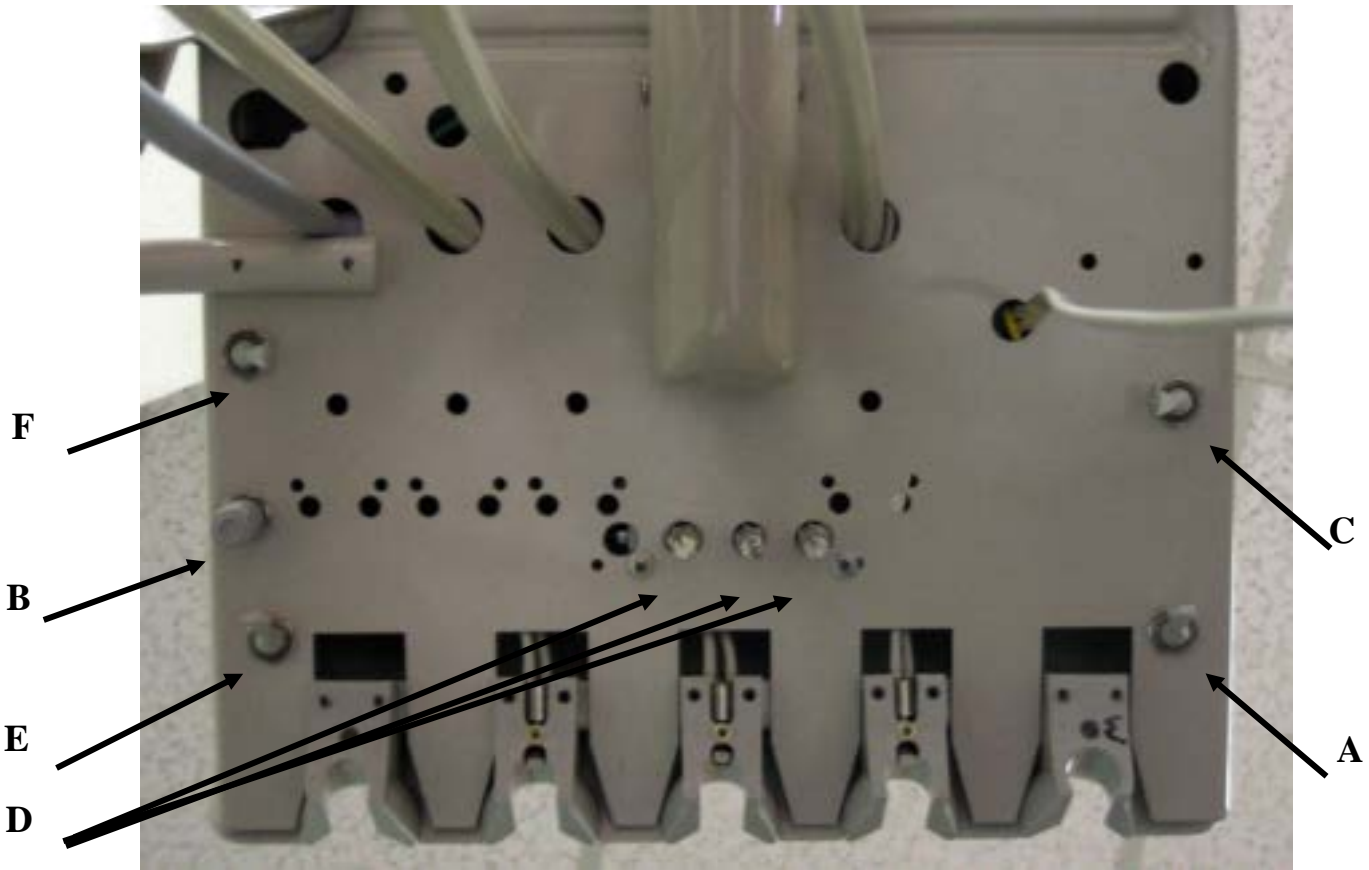

A) Master Air & Water On/Off toggle

Opens and closes the Air/Water valves in the Utility Center Box. Supplies Air and Water to complete delivery system. **(MUST BE SHUT OFF NIGHTLY.)**

B) Water coolant flow control knob

Adjust the flow of water coolant to handpieces. Counter-clockwise increases flow. Clockwise decreases flow or water off for low-speeds.

C) Handpiece tubing flush toggle

Remove handpieces from holders and activate the switch to flush Handpieces.

D) Drive-Air Pressure control knob

Adjusts the drive air pressure to the Handpiece selector. Turn clockwise to decrease pressure, and counter- Clockwise to increase.

E) Water On/Off toggle

F) Arm Brake

Tubing Color Guide

1/4" Black	Drive Air in
1/8" Red	Master Air in
1/8" Yellow	Return Air out
1/8" Pink	Bowl Flush
1/8" orange	Cup Fill

1/8" Blue	Water In
1/8" Brown	Syringe Air
1/8" Green	Wet/Dry
1/8" Clear	Air Brake release

Troubleshooting Guide

Delivery System

Symptom	Possible cause	Corrective action
Air bubbles present in syringe or water coolant flow	Cross leakage through the diaphragm in the utility center filter-regulator.	Replace diaphragm
Water in syringe air or in handpiece drive air.	Cross leakage through the diaphragm in the utility center filter-regulator.	Replace diaphragm
	Water in supply line.	Close manual air valve in utility center and remove the filter/regulator assembly. Open manual air valve and check for moisture in the air supply. If water is present, service or install compressed air dryer.
Water drips continuously from handpiece when foot control is not depressed.	Non-retracting Water Relay Valve faulty.	Check using another handpiece. If symptoms are the same check water relay valve.
	Partially clogged handpiece water port.	Check using another handpiece.
Handpiece runs while still in the auto-holder.	Pilot valve in the rear of autoholder is out of adjustment.	Turn master switch OFF. Loosen setscrew at bottom of auto-holder assembly, and adjust pilot valve in slightly. Tighten setscrew.
	Handpiece is in the wrong holder.	Assure that handpiece hoses are not crossed.
Inadequate air flow to unit.	Clogged filter element in filter-regulator assembly.	Replace filter element
	Inadequate air from foot control.	See Foot Control Troubleshooting Guide.
	Pinched supply tubing.	Check supply tubing in selector head, utility center and in flex arm.
Water in syringe air only.	Water in air supply line.	Close manual air valve in utility center and remove filter/regulator assembly. Open manual air valve and check for moisture in the air supply. If moisture is present, service or install compressed air dryer.
	Syringe tip improperly installed.	See three-way syringe Troubleshooting Guide.
Gauge does not read handpiece air pressure.	Tubing at rear of gauge is pinched against chassis.	Push the gauge back towards the rear of delivery head.
	Bracket around gauge is too tight and pinches casing.	Slightly loosen screw(s) holding bracket and test.

Cuspidor Troubleshooting

Symptom	Possible cause	Corrective action
Water does not flow from cup fill spout	Check that the Manual water shut-of valve is turned on. (J-Box)	Turn valve Counter Clockwise to open valve
	MSO Water Filter is clogged	Unscrew the water filter body and check for clogged filter. Replace as needed
	Water regulator is not operating properly	Unscrew the lock nuts and turn the thumbscrew in and out. Clockwise increases pressure counter clockwise decrease pressure. If this doesn't work replace regulator. Regulator is factory set at 80 psi.
	¼" blue tube is pinched off, or stretched too tightly. Disconnect tube from the cuspidor box and check water flow.	Replace or repair as needed.
	Cuspidor shut-off valve is not working properly	Disconnect the 1/8" Orange tube from the shut-off valve inside the cuspidor and check the signal from the delivery system remote toggle, and or the Assistants Box toggle for proper signal. Replace valve as needed.
Water does not flow from Timed Bowl Rinse Spout	Refer to possible causes for cup fill spout	Refer to possible solutions for cup fill spout
Cuspidor doesn't drain properly	Cuspidor bowl is not leveled properly	Using a bubble level, place it perpendicular to the chair. Cuspidor Bowl should be tipped 3 degrees towards the toe of the chair. Use 1/8" Allen wrench on cuspidor leveling screw. (Note water flows down hill)
	Cuspidor Drain tubing is pinched	Locate problem and fix or replace as needed. If problem isn't the tubing and there is not a visible reason that the cuspidor should not drain. You may need to install a vacuum drain kit.

Foot Control Troubleshooting

Symptom	Possible Cause	Test procedure	Corrective Action	
			If test is Normal	If test is Abnormal
Audible leakage while the Foot Control is not being used.	Loose mounting screws.	Turn Foot Control face down and tighten the two Phillips-head screws at the center of the baseplate.	If the leakage stops, no further action is required.	If leakage does not stop, proceed with the next step.
	Loose tubing connection.	Note "WARNING" in the DESCRIPTION heading. Remove the Foot Control cover and use a soap solution, if necessary, to locate the source of the leakage.	If the air is leaking around a barb connection, tighten the barb and re-test the valve.	If the air is leaking from the exhaust vent or around the bottom of the valve body, proceed with the next step.
	Defective O-Rings or sealing surface.	Turn the unit OFF and bleed the air pressure, then disassemble the Foot Control. Inspect the O-Ring and sealing surfaces for defects or debris.	If no defects are noted, carefully clean and lubricate the parts. Reassemble and test the valve.	Replace any defective parts. Carefully clean and lubricate the parts. Reassemble and test the valve.
Inadequate air flow from the Foot Control.	Pinched tubing going to or from the Foot Control.	Inspect the Foot Control for crimps or restrictions.	If no problem is found, proceed with the next step.	If tubing is crimped. Install a new tube. Assemble and test the unit.
	Obstruction at the inlet or outlet.	Note "WARNING" in the DESCRIPTION heading. With the cover removed, depress the piston and check for adequate airflow.	If no defects are noted, carefully clean and lubricate the parts. Reassemble and test the valve.	Replace any defective parts. Carefully clean and lubricate all parts. Reassemble and test the valve.
Foot control is sluggish.	Stem may be Sticking.	Note "WARNING" in the DESCRIPTION heading. Remove the valve body from the base. Remove and inspect the O-Rings and spacers for debris or defective parts.	If it works easily and smoothly, check for a weak or improperly installed spring.	If there is any sticking or binding, remove the stem, spacers, and O-Rings. Replace any defective parts. Carefully clean and lubricate all parts. Reassemble and test the valve.

Foot Control Troubleshooting (continued)



EQUIPMENT ALERT

Before removing the foot control cover, turn the air supply OFF and bleed all pressure from the system. Failure to do so can result in the stem assembly being ejected from the foot control valve.

Description

The Foot Control is actuated by foot pressure on the cover, which depresses the stem assembly in the valve bore. This moves the fluted surface of the stem below the inlet O-Ring seal, allowing air to flow to the outlet. When foot pressure is released, the stem returns, sealing the inlet at the O-Ring. Any pressure from the outlet side of the valve is then exhausted as the fluted surfaces move above the outlet O-Ring seal.

Foot Control Parts Breakdown

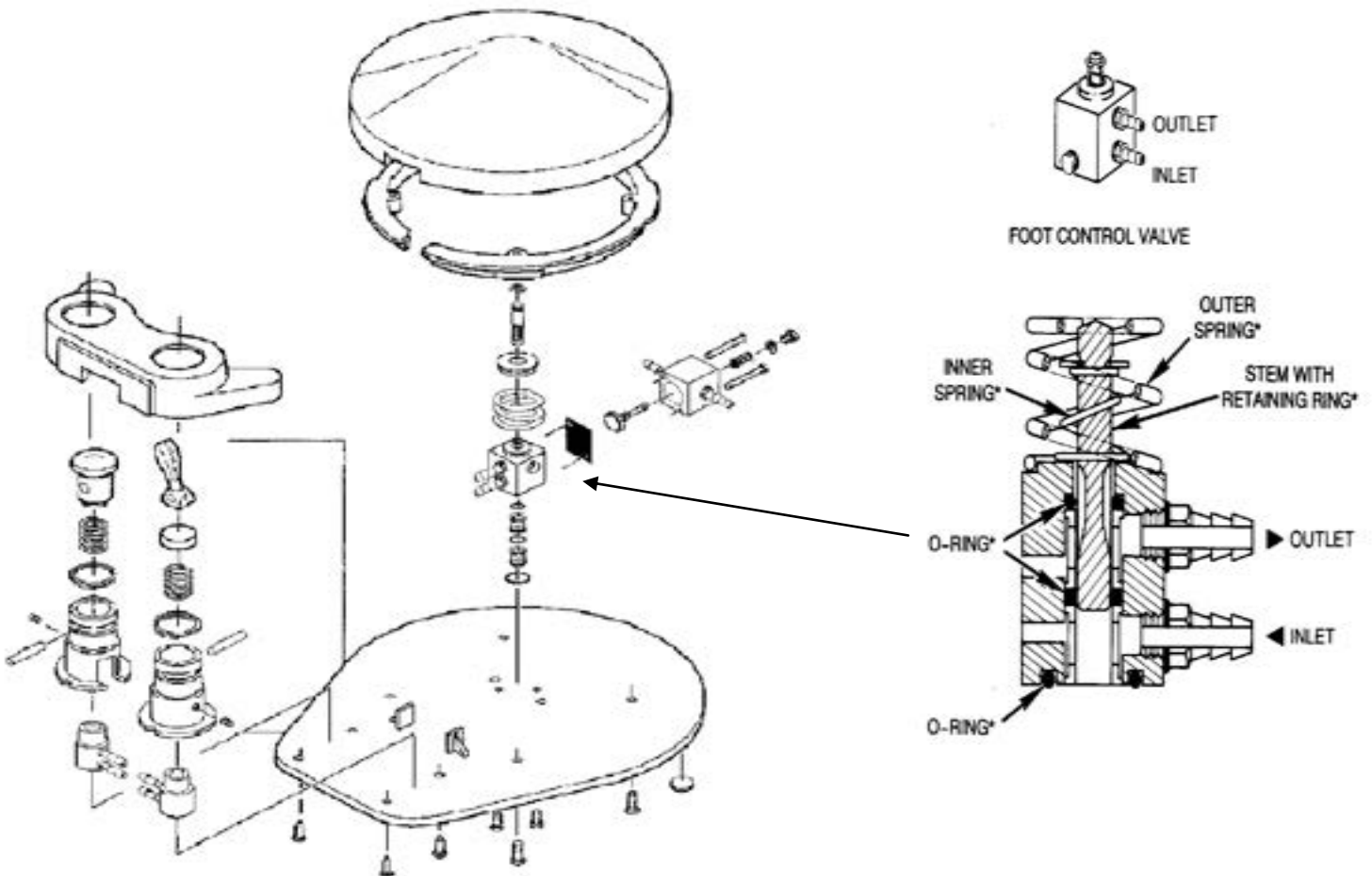

Three-way syringe Installation



EQUIPMENT ALERT

Never install a three-way syringe in a system without a provision for turning off air and water supplies. When the operator is unattended or when maintenance is being performed, both the air and water supplies should be turned off.

Installation and removal of syringe tip

Install: Depress collar (3) and insert base of tip (1) into the hexagonal hole on adapter (2). Gently push in on tip until it is seated in syringe head. Release collar (3) to lock the tip in position. Always make sure the syringe tip is fully inserted and locked. Pull lightly on the syringe tip to test before using.

Remove: Depress collar (3); gently pull tip(1) from adapter (2).

Installation of tubing

Turn off air and water supply. Connect syringe air and water tubing to air and water ports on dental unit or syringe manifold.

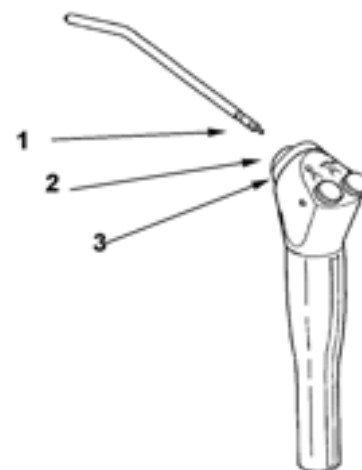

Three-way syringe Troubleshooting

A) Momentary water spray when air button is pressed

- 1) Check that tip is properly seated and locked by pulling lightly on syringe tip. If not seated and locked see the instructions for Installation and Removal of Syringe Tip. If not seated and locked see the instructions for Installation and Removal of Syringe Tip. If tip was seated and locked, O-rings (4&6) need to be replaced- go to following steps.
- 2) Remove tip (1) from adapter (2).
- 3) Important note: while removing adapter (2) and collar (3), be careful to position collar (3) so ball bearings housed inside it do not fall out. Insert 5/32" Allen wrench into the hexagonal hole on adapter (2), and turn wrench to remove adapter. Remove O-rings (4&6).
- 4) Apply a light coating of silicone lubricant to new O-rings (4&6). Install O-rings on adapter, and carefully reinstall spring (5), collar (3) and adapter (2) on syringe head. Use Allen wrench to firmly tighten adapter.

B) Air or Water leakage around buttons

- 1) Use paper clip to push retaining pin (14) completely out of syringe body. Remove the problem button assembly from syringe.
- 2) Use needle nose pliers, or forceps, to remove retaining ring (13) from button assembly. Remove brass spool (9) from button stem (10).
- 3) Note position of O-ring (12) on brass spool, and O-ring (11) on button stem. Use a sharp instrument to cut both O-rings. Remove O-ring from the stem assembly.
- 4) Apply a light coating of silicone lubricant to all new O-rings. Install O-ring (12) on brass spool, and O-ring (11) on the button stem in positions noted in step 3. Insert button stem through brass spool. O-ring (8) is positioned between the bottom of brass spool and retaining ring (13).
- 5) Note the position of spring (7), and insert spring into syringe head. Insert button assembly on top of spring, and secure it in the syringe head with retaining pin (14).

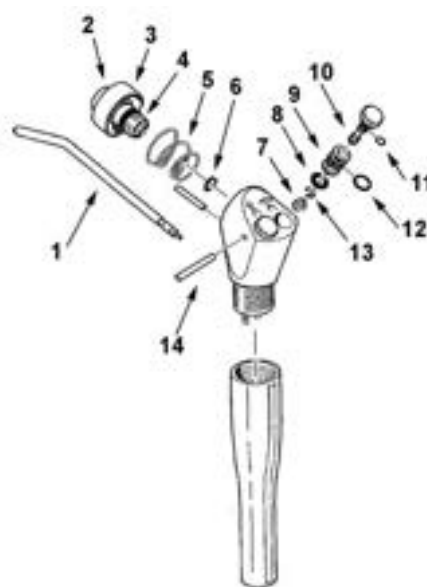

HVE/SE Care Maintenance and Sterilization

After Each Patient

Immerse the suction tip in clean water. Open and close the valve 3 times. This will decrease the accumulation of particles in the spool valve area, which can interfere with the valves operation.

Daily Care

Immerse the suction tip in clean water. Open and close the valve 3 times. Using a rigid brush approximately 3/8" in diameter brush the internal surfaces.

As Needed

When the bail lever becomes difficult or is sticking, you will need to remove the Spool Valve to clean and lubricate the internal components.

To remove the spool valve (refer to figures A and B):

- 1) Gently pry the bail lever out from the valve on one side until it is free from the recesses in the spool.
- 2) Push the spool out of the valve.

Thoroughly clean the surfaces, and inspect the O-rings for wear or damage. Replace O-rings that have nicks, cuts, flat spots or other signs of damage.

Surface Disinfecting

Do not use Sodium Hypochlorite or any bleaching agents to clean these instruments. They will cause permanent damage.

Sterilization

Autoclavable vacuum valves should be steam autoclaved between patients. The following protocol should be followed:

HVE – steam autoclave at 134°C (273 °F), 6 minutes holding time

SE – steam autoclave at 134°C (273 °F), 6 minutes holding time

Air/Water Syringe - steam autoclave at 134°C (273 °F), 4 minutes holding time

Regardless of the process used, temperatures should never exceed 280 degrees Fahrenheit or 138 degrees Celsius.

Do not allow the instrument to come into contact with the walls of the sterilizer. Avoid placing the instrument in close proximity to the sterilizer heating element.

Each handheld device with air and water lines should be discharged for 20-30 seconds between each patient to reduce the chance of cross-contamination as a result of potential bio-burden retraction.

Specifications

Minimum air, water and vacuum service requirements for proper unit operation:

Air: 2.50 cfm (70.80 l/min) at 80 psi (551 kPa).

Water: 1.50 gpm (5.68 l/min) at 40 psi (276 kPa).

Vacuum: 12 cfm (339.84 l/min) at 8 inches of mercury (27 kPa).

Specifications are subject to change without notice



**HVE valve
Fig A**

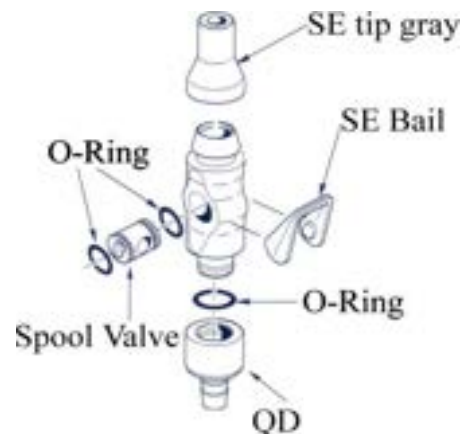

**SE valve
Fig B**

Eco-Sys Control Head and Cuspidor Schematics

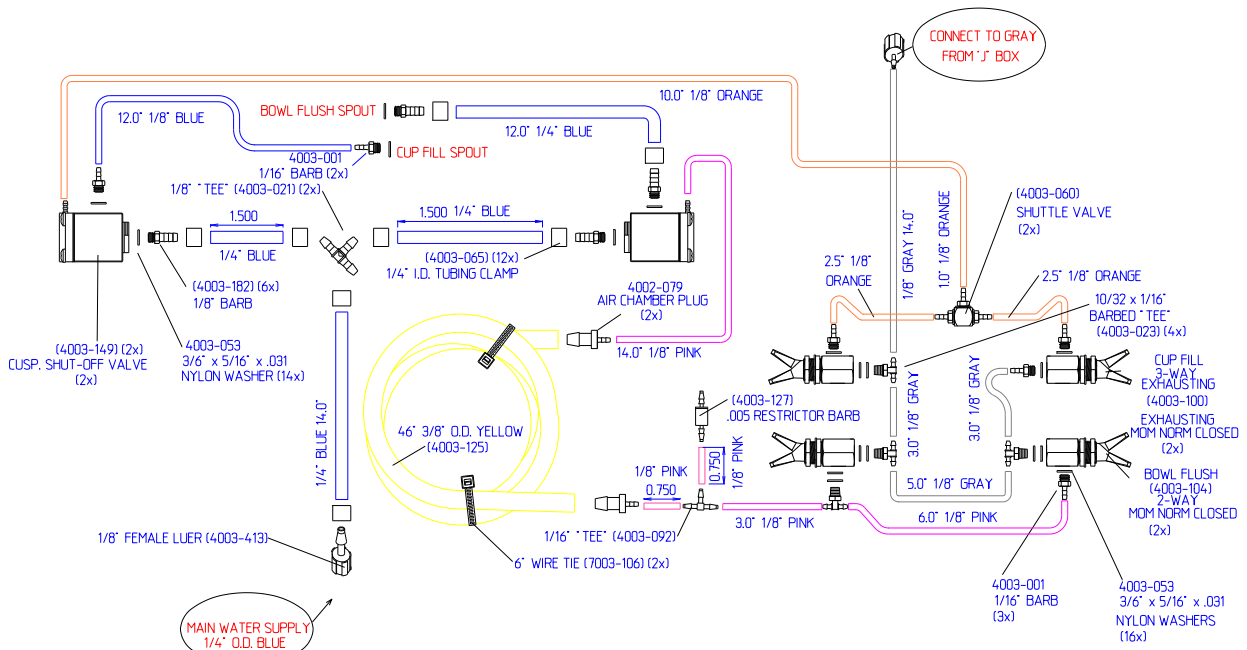
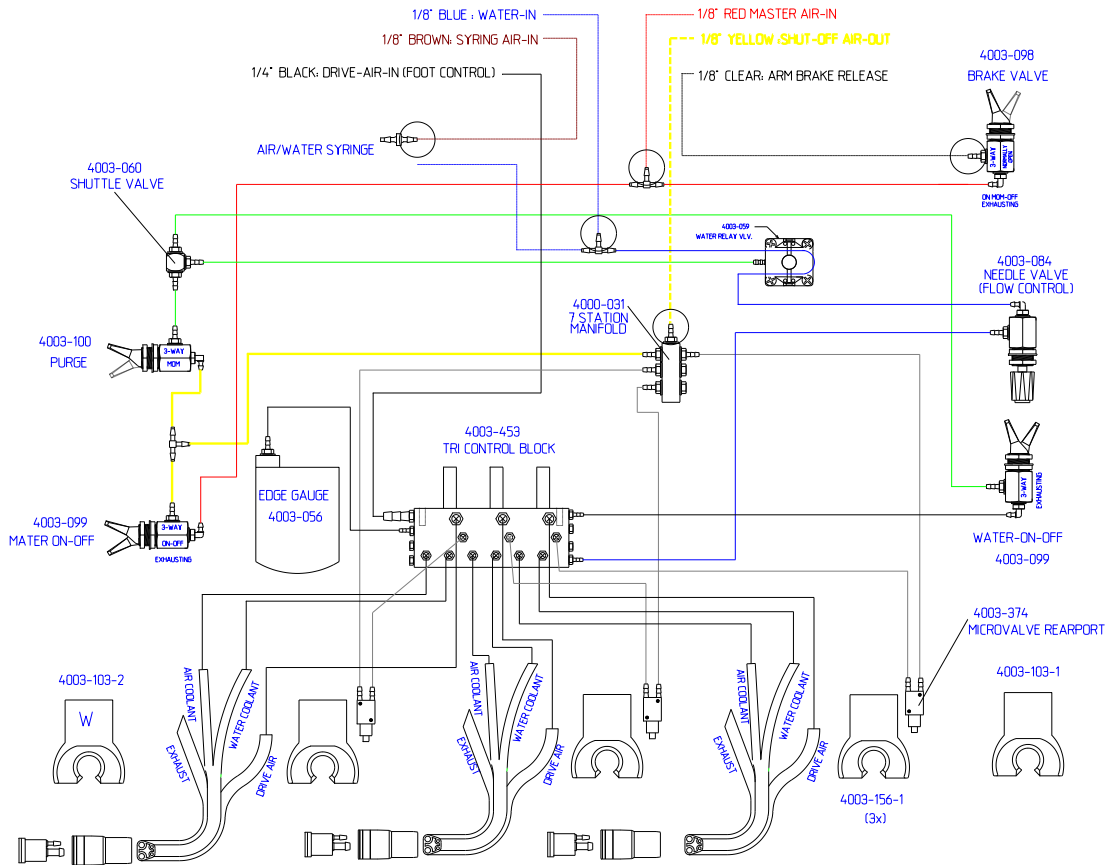

Contamination control system

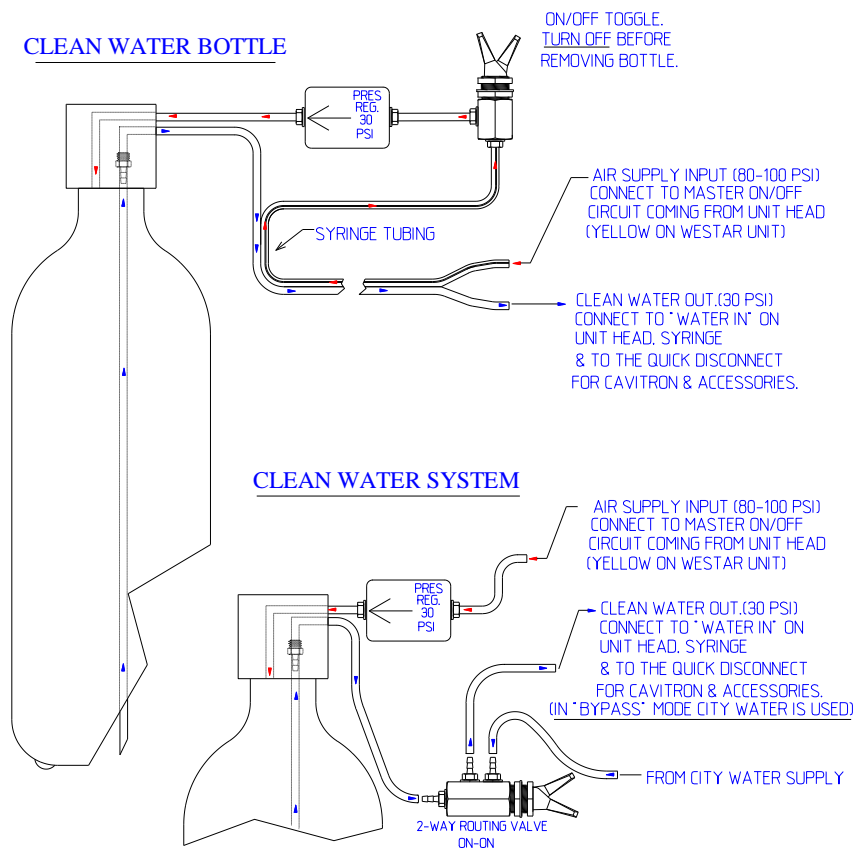

Belmont Series Delivery Systems Dimensions and Specifications

