

# PHOT-X IIS

Model 505

*DENTAL X-RAY*

**LCD**

## INSTALLATION INSTRUCTIONS (for USA)

*Wall Mount Type.....WK*

### **⚠ WARNING**

This x-ray equipment may be dangerous to patient and operator unless safe exposure factors, operating instructions and maintenance schedules are observed.

### **⚠ CAUTION**

This manual provides information and instructions for the installation, assembly, calibration and certification procedures for **the BELMONT PHOT-XIIs Model 505** dental x-ray.

The instructions contained in this book should be thoroughly read and understood by dealer service personal before attempting to install the X-ray unit. After installation is completed, owners should file this manual and refer back to it to schedule periodic maintenance.

If this manual is lost or damaged, order the manual by the book number written on the last page.

 **Belmont**<sup>®</sup>

# INDEX

	PAGE
<b>SECTION 1 : TECHNICAL DATA</b>	
[1] ELECTRICAL AND RADIATION DATA -----	2
[2] PHYSICAL DIMENSIONS -----	3
[3] TUBE HEAD THERMAL CHARACTERISTICS -----	4
<b>SECTION 2 : PRE-INSTALLATION INSTRUCTIONS</b>	
[1] SUPPORT REQUIREMENTS -----	5
[2] ELECTRICAL REQUIREMENTS -----	5
[3] LOCATION OF COMPONENTS -----	6
<b>SECTION 3 : INSTALLATION INSTRUCTIONS</b>	
[1] INSTALLATION REQUIREMENTS -----	7
[2] UNPACKING -----	7
[3] MAIN CONTROLLER AND ARM INSTALLATION -----	8
[4] HEAD ASSEMBLY INSTALLATION -----	13
[5] SUB CONTROLLER INSTALLATION -----	15
[6] HAND EXPOSURE SWITCH (OPTION) -----	16
[7] EXTERNAL INTERLOCKS (NOT SUPPLIED) -----	16
<b>SECTION 4 : POST INSTALLATION CONFIRMATION AND SETTING</b>	
[1] ARM ASSEMBLY -----	17
[2] BALANCE ARM TENSION ADJUSTMENT -----	17
[3] HEAD POSITIONING -----	17
[4] CONFIRMATION OF POWER SUPPLY VOLTAGE -----	18
[5] INITIAL SETTING AND CONFIRMATION AFTER POWER ON -----	18
<b>SECTION 5 : CONTROL IDENTIFICATION AND OPERATION</b>	
[1] MAJOR COMPONENTS AND CONTROL IDENTIFICATION -----	21
[2] FUNCTION OF CONTROLS -----	22
[3] OPERATING PROCEDURES -----	26
[4] OPTIONAL HAND EXPOSURE SWITCH -----	26
[5] SETTING MODE -----	27
[6] DISPOSAL -----	28
[7] ERROR CODE -----	29
[8] MAINTENANCE -----	30
<b>APPENDIX 1 : CIRCUIT DIAGRAM -----</b>	<b>31</b>
<b>APPENDIX 2 : MAINTENANCE CHECK LIST -----</b>	<b>32</b>
<b>APPENDIX 3 : PARTS IDENTIFICATION</b>	
[1] ARM AND HEAD ASSEMBLY -----	33
[2] CONTROLLER ASSEMBLY -----	34
<b>APPENDIX 4 : CERTIFICATION -----</b>	<b>35</b>

## SECTION 1: TECHNICAL DATA

### [ 1 ] ELECTRICAL AND RADIATION DATA

1. X-ray tube (Stationary Anode) ----- D-046 or KL11-0.4-70 (See the label on head)
  - a. Nominal focal spot value ----- 0.4 (IEC60366)
  - b. Target Material ----- Tungsten
  - c. Target angle ----- 12.5 deg (D-046), 12 deg (KL11-0.4-70)
  - d. Maximum anode heat content ----- 4.3 kJ (6.1 kHU)
2. Maximum x-ray tube assembly heat content ----- 293kJ (413 kHU)
3. Rated peak tube potential ----- 60 kV / 70 kV selectable
4. Rated tube current ----- 3 mA / 6 mA selectable
5. Maximum rated peak tube potential ----- 70 kV
6. Rated line voltage ----- 120 VAC, 60 Hz, Single phase, 1.2 kVA
7. Line voltage range ----- 108 VAC ~ 132 VAC
8. Range of line voltage regulation ----- 0 ~ 5 % (Apparent resistance 0.52 ohm)
9. Rated line current ----- 10 A at 70 kV, 6 mA
10. Maximum line current ----- 11 A at 70 kV, 6 mA
11. Exposure time ----- 0.01 ~ 2.0 sec.
12. Inherent filtration ----- 1.7 mm Al Equivalent
13. Added filtration ----- 0.3 mm Al
14. Minimum filtration permanently in useful beam ----- 2.0 mm Al Equivalent at 70 kV
15. Nominal radiation output
 

	60 kV		70 kV	
	3 mA	6 mA	3 mA	6 mA
a. Distal end of regular cone -----	4.6	9.1	5.9	11.8 mGy/sec. ± 40%
b. Distal end of long cone -----	2.0	4.1	2.6	5.2 mGy/sec. ± 40%

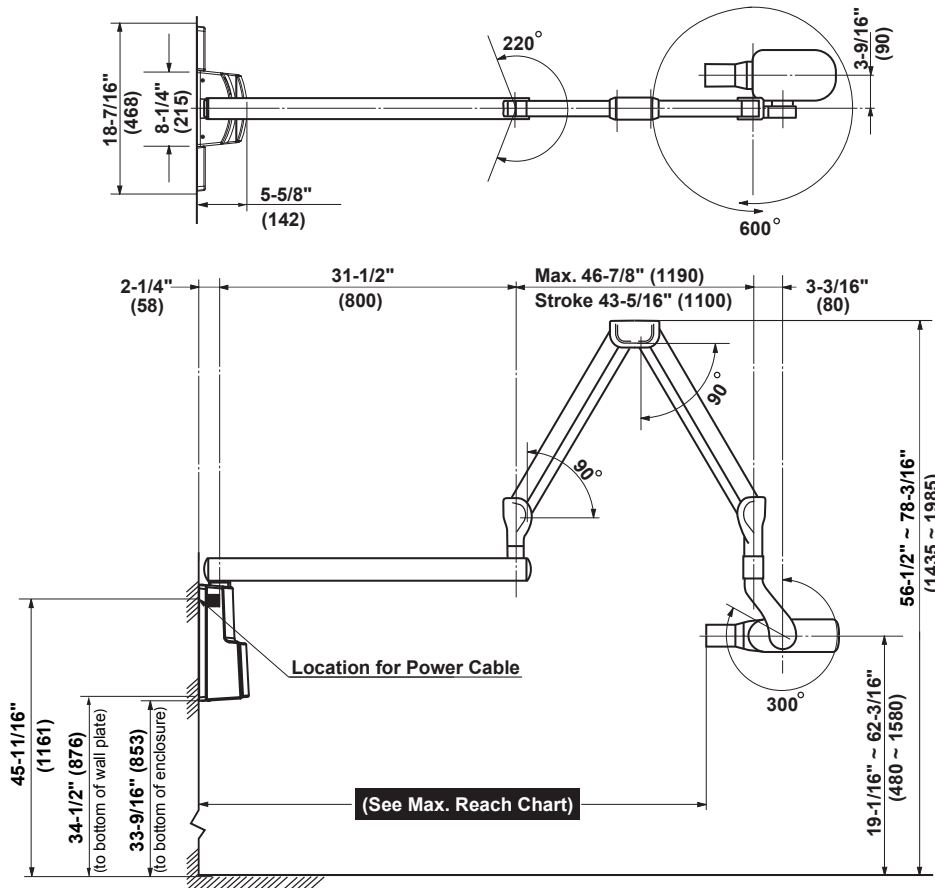
(Data obtained by direct measurement in the useful beam)
16. Nominal electrical output of H.V. generator ----- 0.42 kW at 70 kV, 6 mA
17. Cone
 

	Source to skin distance	Field size
a. Regular cone -----	8 inches (203 mm)	58 mm dia., circular
b. Long cone (option) -----	12 inches (305 mm)	58 mm dia., circular
c. Rectangular collimator (option) -----	SSD of cone + 40mm	32 x 40 mm, rectangular
18. Maximum symmetrical radiation field ----- 60 mm dia. at distal end of cone
19. Leaking technique factor ----- 70 kV / 0.19 mA (697mAs at 1 hour)  
(0.19 mA is maximum rated continuous current for 6mA with a duty cycle 1:30)
20. Duty cycle ----- 1 : 30 (0.5 sec. exposure with 15 sec. interval)
21. Maximum deviation of tube potential, tube current and exposure time
  - a. Below 0.1 sec. setting ----- ±10 kV, ±2 mA, ±5 msec.
  - b. 0.1 sec. setting & up ----- ±5 kV, ±1 mA, ±10 msec.
22. Measurement base of technique factors
  - a. peak tube potential ----- Average of peak tube potentials during one exposure
  - b. tube current ----- Average of tube current during one exposure
  - c. exposure time ----- Time period during x-ray is emitted
23. Half value layer ----- 1.5 mm Al over
24. Source to the base of cone distance ----- 94 mm
25. Environmental condition for storage ----- -20 ~ 70 °C, 10 ~ 100 %, 500 ~ 1060 hPa
26. Environmental condition for operation ----- 10 ~ 40 °C, 30 ~ 70 %, 700 ~ 1060 hPa
27. Dose area product ----- Estimated air kerma displayed [mGy]  
x 26.4 [cm<sup>2</sup>] (for regular and long cone)  
Estimated air kerma displayed [mGy]  
x 12.8 [cm<sup>2</sup>] (for rectangular collimator)

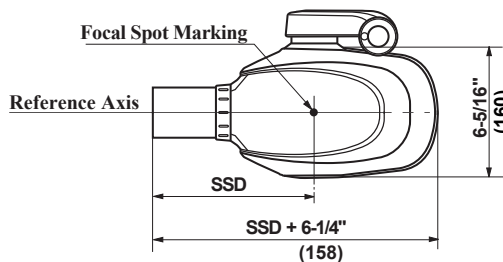
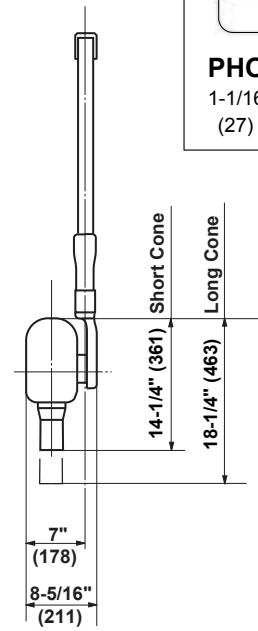
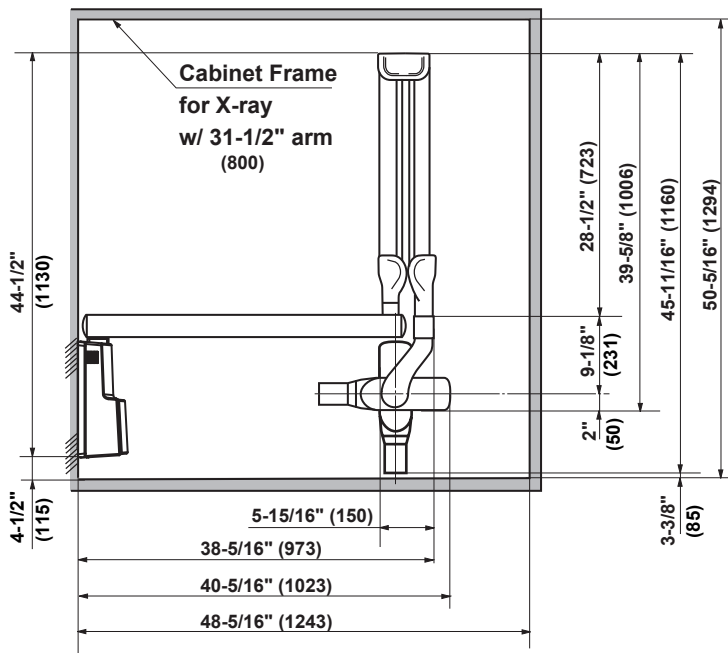
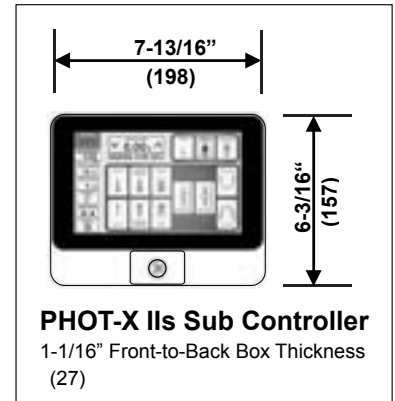
# [ 2 ] PHYSICAL DIMENSIONS

( ) =mm

\* 8-1/4" is the Pass-Thru Plate Width, if Optional 097PTP is ordered and Housing Side Panels are Removed.



Maximum Reach	
84-1/8" with 40.0" arm (2122)	(1000)
75-5/8" with 31.5" arm (1922)	(800)
64-1/8" with 20.0" arm (1622)	(500)
56-1/8" with 12.0" arm (1422)	(300)



SSD (Source to Skin Distance) :

- a. Regular cone ----- 8 inches (203mm)
- b. Long cone ----- 12 inches (305mm)

Note : Installation of rectangular collimator (p/# 1P05DBA0) increases SSD by 40 mm from above value.

Fig. 1-1 Dimensions

### [ 3 ] TUBE HEAD THERMAL CHARACTERISTICS

#### A. Interval between each exposure

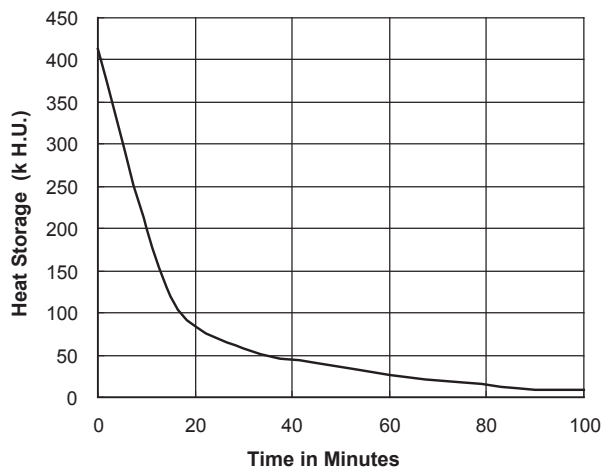
The temperature inside of the tube head rises when an exposure is made. The value of the heat generated is measured in Heat Units (HU), which is the product of tube potential, tube current and exposure time. Excessive heat will accumulate inside of the tube head if the x-ray is used without a proper cool down interval between each exposure. The excessive heat may damage the x-ray tube, high voltage generator or both.

#### B. Duty cycle

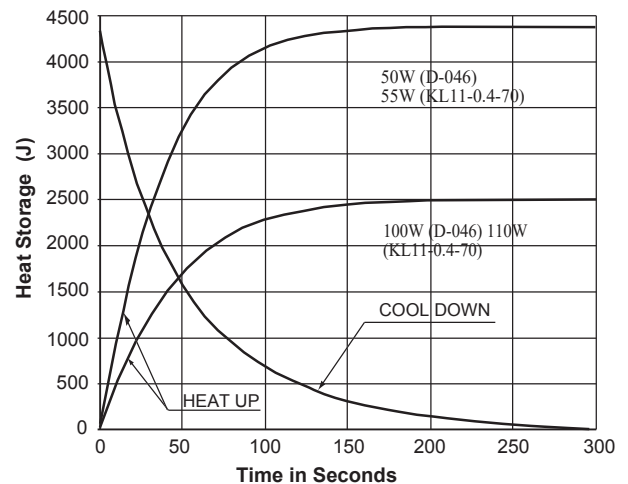
A cool down interval of 30 seconds or more must be allowed between each 1 second exposure. (a 15 second cool down must be allowed between each 0.5 second exposure.) This will avoid the accumulation of excess heat and prolong the tube head life.

#### C. Tube head cooling curve

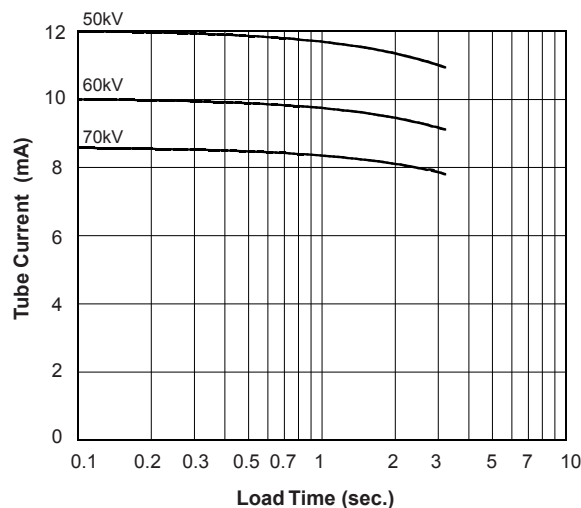
##### 1. Tube Hosung cooling curve



##### 2. Anode thermal characteristics



##### 3. Maximum rating chart



## SECTION 2 : PRE-INSTALLATION INSTRUCTIONS

### [ 1 ] SUPPORT REQUIREMENTS

#### A. Main Controller :

The main controller of Model 505 has wall plate designed for mounting on 2 x 4 wood studs with 16 inches (406mm) centers. The wall and mounting hardware must be sufficient to withstand a **100 pound (45kg) shear load** and a **450 pound (205kg) withdrawal force** at each of the four (ø 9 x 75 mm) lag screws.

#### B. Sub Controller :

When mounting the sub controller, the wall and mounting hardware must be sufficient to withstand a **10 pound (4.5kg) shear load**.

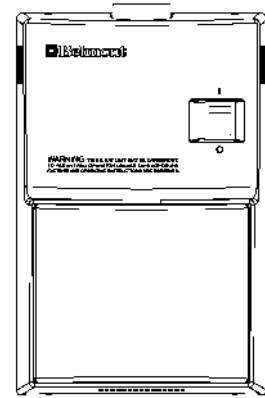


Fig.2-1 Main Controller

### ⚠ CAUTION

**If the PHOT-X IIs Model 505 is to be mounted in a manner other than what is specified in this manual or if the hardware to be used is other than what is supplied, the support capability of the wall and the strength of the hardware must be checked and verified to be adequate.**

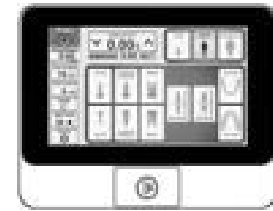


Fig.2-2 Sub Controller

### [ 2 ] ELECTRICAL REQUIREMENTS

#### A. Power supply :

The Model 505 x-ray system requires a power supply of 120VAC ±10 % (108 ~ 132V AC) with a 3-wire GROUNDED circuit. It is recommended to be separately connected to the central distribution panel with an over-current protection device rated for 16 amperes. Recommended wire size is 14 AWG, but if the wire run distance exceeds 50 feet (15m), 12 AWG is required. For wire run distances more than 75 feet (23m), 10AWG is required. Line voltage regulation must be within 0 ~ 5 % at 11 amps.

### ⚠ WARNING

**To avoid risk of electric shock, this equipment must only be connected to a supply mains with protective earth.**

#### B. Concealed wiring :

Route conduit and wires through wall and into (2) flush mounted junction boxes located (1) behind the main controller and (1) behind the sub controller. Recommended heights above the finished floor for the flush junction boxes are : 44-7/8 inches (1140mm) for the main controller and 56 inches (1420mm) for the sub controller. Wiring done in this manner should extend 12 inches (300mm) beyond the wall surface to allow sufficient wire for connections.

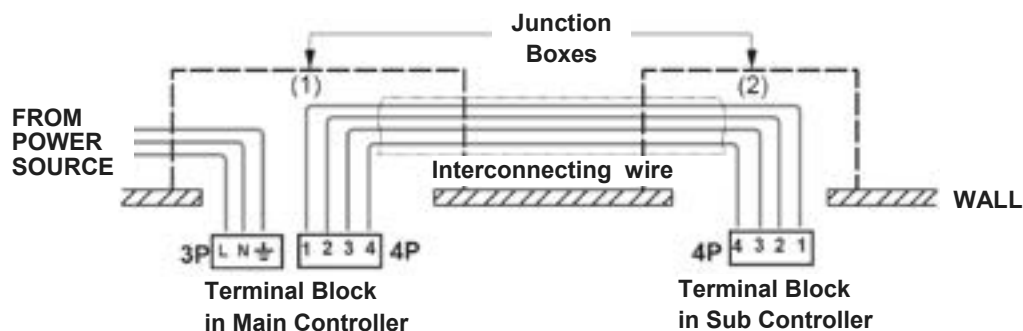


Fig.2-3 Concealed Wiring

**Note :** Follow local and national electrical code (NFPA 70) requirements during installation.

**C. Interconnecting wiring between main controller and sub controller:**

4 conductors, 20 AWG, 300V, 33 feet (10m) cable is included. Use this cable as interconnecting wires between main controller and sub controller.

**⚠ CAUTION**

Only the cable included in PHOT-XIIs x-ray should be used as interconnecting cable. If thinner or longer cable is used, communication error (E.22) might be happened.

**[ 3 ] LOCATION OF COMPONENTS**

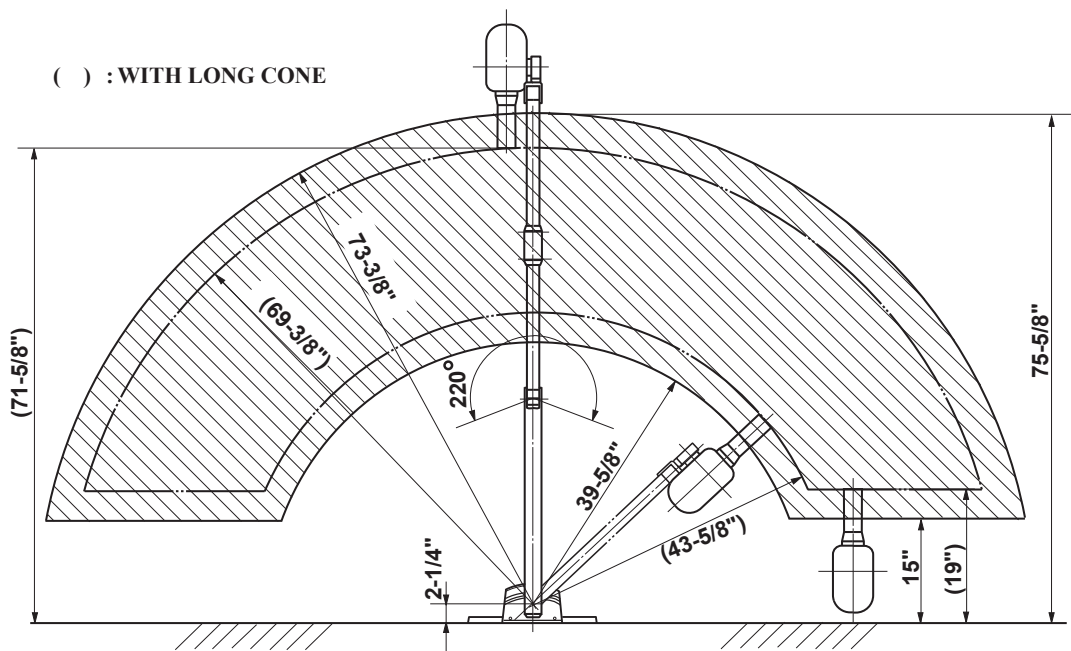
**A. Main Controller, Arm and Head Assemblies :**

Using the information Provided in Fig.2-4, determine the correct location for the main controller.

**⚠ CAUTION**

The PHOT-XIIs Model 505 x-ray unit should be installed on the wall that prevents the horizontal arm rotate 360°.

**NOTE :** State and local requirements supersede guide lines indicated below.



**Fig.2-4** Radius of Activity for X-ray Head

**B. Sub controller :**

When determining the location for the sub controller, the following radiation requirements concerning the operator's positioning must be considered.

The operator must :

1. have full view of the patient.
2. have means for audio and visual communication with the patient.
3. have full view of kV, mA, timer selections and exposure warning light.
4. be at least 2 m away from the x-ray head and patient and out of the path of the x-ray beam or be positioned behind a protective device.

## SECTION 3 : INSTALLATION INSTRUCTIONS

Within the installation and confirmation procedures are inspection/test steps which the installer must perform to insure that the installation meets the manufacturer's specifications. These steps require the installer to record the necessary information onto the "ASSEMBLER'S INSTALLATION REPORT " section of the limited warranty report from supplied, which **MUST** be returned to BELMONT along with the warranty card.

### [ 1 ] INSTALLATION REQUIREMENTS

#### Tools :

Standard tool kit including 1.5 mm, 2 mm, 3 mm and 5 mm allen keys.

#### Instruments :

- Digital multimeter with an accuracy of 1%, capable of measuring 150 V AC and 10 mA DC, and capable of indicating true RMS value within 1 sec.
- tandard calculator.

#### Power Supply :

Prior to starting the installation, inspect the power supply and confirm that it is 120VAC  $\pm$ 10%, and a 3-wire GROUNDED circuit. It is recommended to be separately connected to the circuit breaker panel with an over current protection device rated for 16 A. (Refer to Page 5, [2])

**Record the voltage reading of power supply on "Assembler's Installation Report".**

### [ 2 ] UNPACKING

Unpack the entire contents of the shipping carton. Included within the shipping carton are :

<u>Hardware</u>	<u>Quantity</u>
Head with Regular Cone -----	1
Main Controller-----	1
Screw for chassis (M4 x 10 mm)-----	4
Screw for chassis (M4 x 20 mm)-----	1
Stopper Ring -----	1
Front cover seal-----	4
Wall Plate-----	1
Lag Screws for wall plate ( $\varnothing$ 9 x 75 mm)-----	4
Arm Mounting Bracket-----	1
Machine Bolt (M8 x 20 mm) -----	3
Washer (M8) -----	3
Sub Controller -----	1
Sub Controller Mounting wood screw ( $\varnothing$ 4.1 x 20 mm) for wall-----	4
Sub Controller Mounting screw (M3 x 6 mm) for main controller-----	4
Head key-----	1
Arm collar -----	1
Balance Arm -----	1
Balance Arm Wrench -----	1
Horizontal Arm W/2 x End Caps-----	1
Brake Screw (M6 x 6 mm)-----	2
Brake Plug (Brass Plug $\varnothing$ 5 x 4 mm)-----	2
Retaining Bolt (M6 x 35 mm) -----	2
Stopper Screw (M6 x 15 mm) -----	1
Brake Spring ( $\varnothing$ 5 x 11mm)-----	1
Hook for side cover -----	4
Screw for hook (M4 x 6mm) -----	8
Interconnecting wires (10m) -----	1
Sensor holder assembly -----	1
Shims -----	6
<u>Documentation</u>	<u>Quantity</u>
Installation manual -----	1
Operators manual-----	1
Limited Warranty / Report Form -----	1
Wall mounting Template -----	1

**Inspect contents of shipping carton for damage or missing components.**

### [ 3 ] MAIN CONTROLLER AND ARM INSTALLATION

The instructions given below are for mounting the main controller assembly on two 2 x 4 wood studs with 16 inch (406mm) centers. Should the PHOT-XIIs Modle 505 be mounted in a manner other than what is specified here, the wall and the strength of the hardware used must be checked and verified as being adequate to withstand a 100 pound (45kg) shear load and a 450 pound (205kg) withdrawal force at each of the four ( $\varnothing 9 \times 75$ mm) lag screws. When using concealed wiring, a flush mounted junction box with the necessary conduit and wiring must be pre-installed at 44-7/8 inches (1140mm) from the floor and between the two studs (refer to wall mounting template).

#### A. WALL PLATE OF MAIN CONTROLLER

##### ⚠ WARNING

**Make sure the power supply is turned OFF at the circuit breaker panel.**

1. Tape the wall mounting template to the wall, positioning it so that the holes for mounting plate lag screws are aligned with the vertical 2 x 4" studs.

**NOTE :** Confirm that the location of concealed wiring matches to the access hole of wall plate template.

2. Mark the hole locations for the mounting plate lag screws.
3. Use a 3/16" (5mm) dia. drill to make a pilot hole approximately 2" (50mm) deep for each mounting plate lag screws.

##### ⚠ CAUTION

**Do not use a drill larger than 3/16" (5mm) dia. for these holes.**

4. Place the wire through the hole into the stud mount wall plate and mount the plate to the stud with the four ( $\varnothing 9 \times 75$ mm) lag screws.  
**DO NOT FULLY TIGHTEN.**

##### ⚠ CAUTION

**Be careful not to mount the wall plate backward**

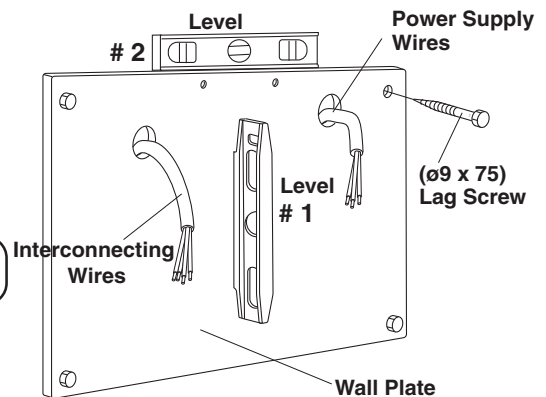
5. Hold the plate firmly against the wall, place a level across the front face. (#1 position in Fig.3-1)  
If the wall is not plumb, use shims behind the plate to level.

6. Place a level across top edge of wall plate, level and tighten lag screws securely. (#2 position in Fig.3-1)

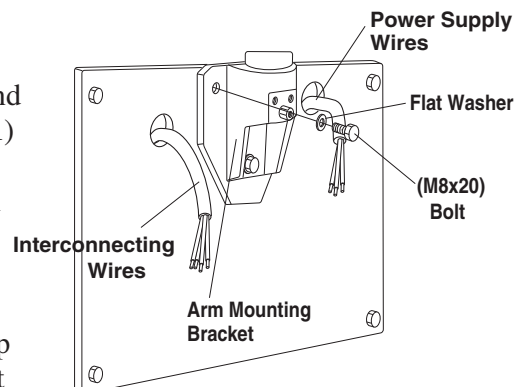
**NOTE :** Final leveling of wall plate is described on page 17.

#### B. ARM MOUNTING BRACKET

1. Using three (M8 x 20mm) bolts with washers in top mounting holes and in lower mounting hole, mount arm mounting bracket to wall plate. (Fig.3-2)



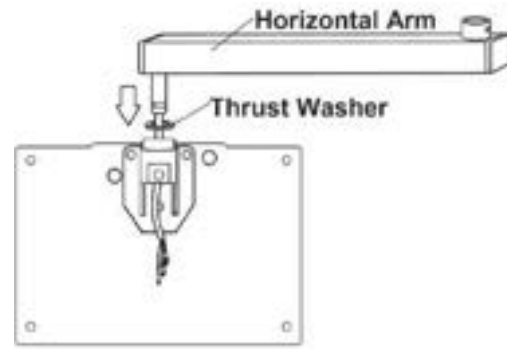
**Fig.3-1** Wall Plate Installation



**Fig.3-2** Arm Mounting Bracket Installation

### C. HORIZONTAL ARM

1. Place a thrust washer over the hole on top of the arm mounting bracket.  
Insert the cable of horizontal arm into the hole, and mount to the arm mounting bracket, as shown in **Fig.3-3**.
2. Insert two retaining bolts into the upper threaded holes of the arm mounting bracket and tighten securely with a Allen wrench. (**Fig.3-4**)

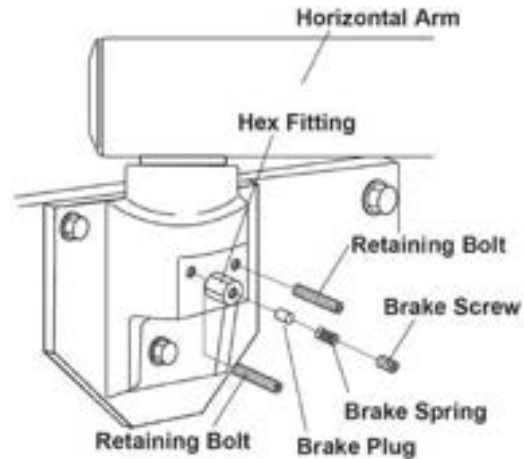


**Fig.3-3** Horizontal Arm Installation

#### IMPORTANT :

**The retaining bolts must be installed to ensure that the horizontal arm can not lift out of the arm mounting bracket.**

3. Insert brake plug, brake spring and brake screw (M6 x 6 mm) into the threaded hole of the hex fitting located on the arm mounting bracket. **DO NOT FULLY TIGHTEN.** (**Fig.3-4**)
4. Place a level on the horizontal arm and confirm that the arm has same positive degree at its left, center and right swing positions. (**Fig.3-5A**)



**Fig.3-4** Horizontal Arm

#### NOTE :

**Arm level will have a minor positive degree to compensate for the head and arm weight.**

- a. To make the angles at left and right positions equal, loosen two top mounting bolts slightly and move the arm brackets to the left or right.
- b. If the angle in the center position is different from the angle at the left and right positions, place the shims supplied between the arm bracket and the wall plate to adjust the angle. (**Fig. 3-5B**)

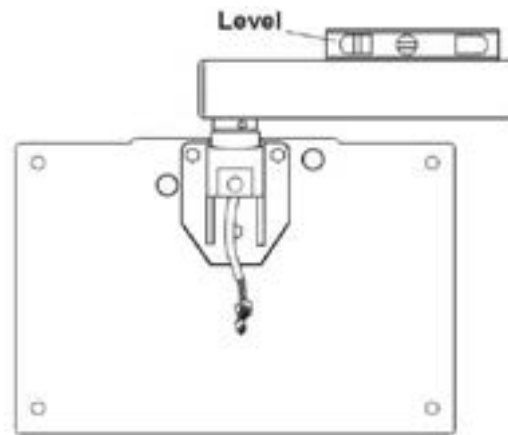
b-1. Insert the shim at the bottom mounting bolt if the horizontal arm tip is low.

b-2. Insert the shims at the top two mounting bolts if the arm tip is high.

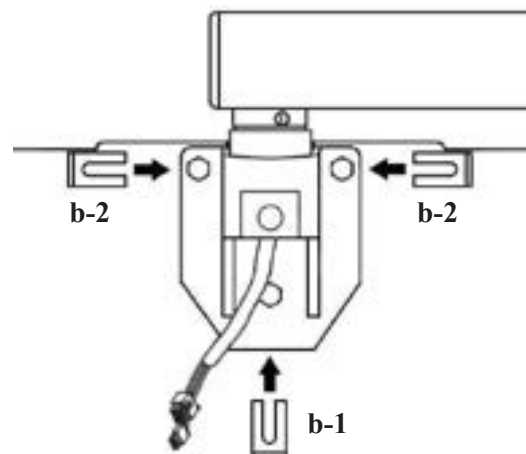
Use more than one shim on the same bolt according to the degree of angle to be corrected.

#### NOTE :

**When using the shim, insert the shim so that the bolt is located inside of the slit of the shim and deeply as the bend of the shim touches the edge of the arm bracket.**



**Fig.3-5A** Level Check



**Fig.3-5B** Shims

## D. CHASSIS OF MAIN CONTROLLER

1. Remove the restriction plate over the terminal blocks by taking out two (M 4 x 8mm) screws. (Fig.3-6)
2. Route electrical interconnecting wires and power supply wires through the access holes on chassis and mount the chassis on the arm bracket with three of four (M4 x 8mm) screws. (A screw at lower right corner should be secured with a green wire from arm at setp 6 on this page. Secure the bottom corner of chassis with two (M4 x 8mm) screws to the wall plate. (Fig.3-6)

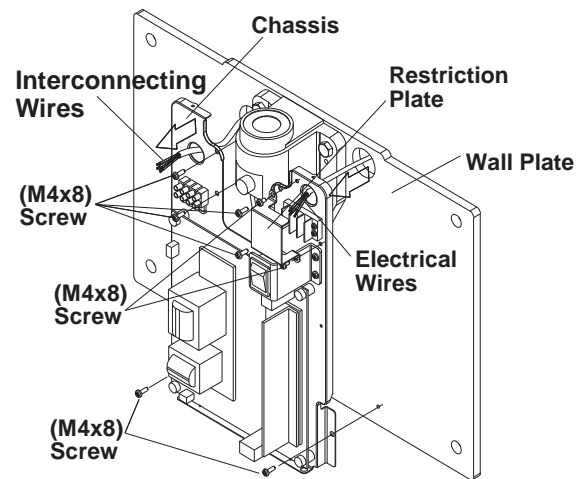


Fig. 3-6 Attaching Chassis to Wall Plate

3. Cut the wires to workable length and strip 3/8" of insulation for power supply wires and 3/16" for interconnecting wires for Sub Controller. Connect power supply wires to 3P terminal block and interconnecting wires to 4P terminal block. (Fig.3-7)

4. Reattach the restriction plate. (Fig.3-7)

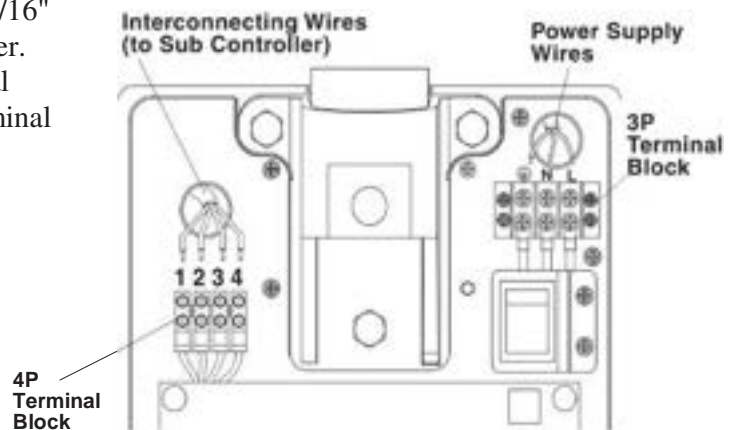


Fig. 3-7 Wires Connection in Main Controller

5. Connect 2P and 8P connectors of horizontal arm cable to the respective connectors on power PC Board. (Fig.3-8)

6. Secure the green wire of arm cable by a lower right corner screw of four screws securing chassis to the arm bracket.

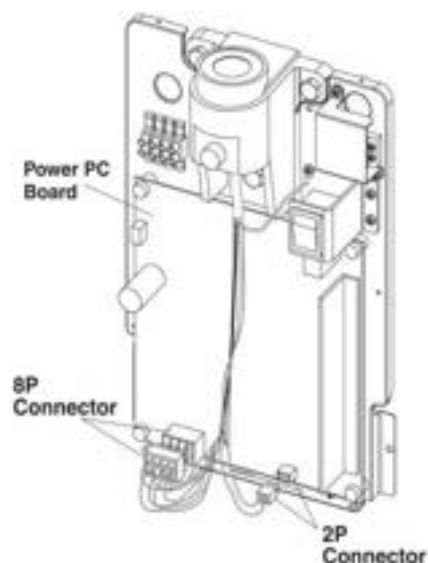
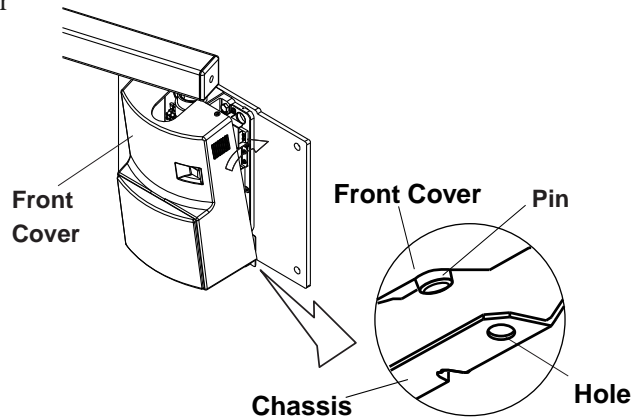


Fig. 3-8 Connecting 2P and 8P Connectors

## E. FRONT COVER

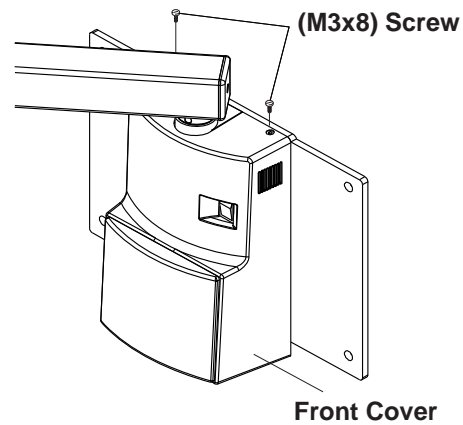
**NOTE :** The front cover for the main controller should not be closed until all installation and the post-installation inspections and confirmation are completed.

1. Set the pins located on the bottom of the front cover into holes on the bottom of metal chassis, and then push the top side toward the wall to close. **(Fig.3-9A)**



**Fig. 3-9A** Setting front cover on chassis

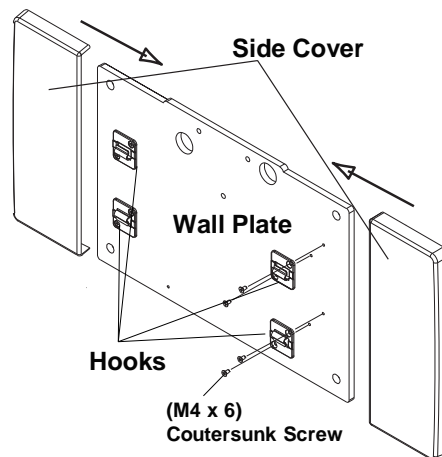
2. Install two (M3 x 8mm) screws into the top of the cover and confirm that the cover is securely attached. **(Fig. 3-9B)**



**Fig.3-9B** Attaching Front Cover

## F. SIDE COVER

1. After the front cover of the main controller is installed, attach four hooks to the wall plate with (M4 x 6mm) screws supplied.
2. Slide in the side cover from right and left side of the wall plate as the hooks catch the side covers. **(Fig.3-10)**



**Fig.3-10** Side Cover Installation

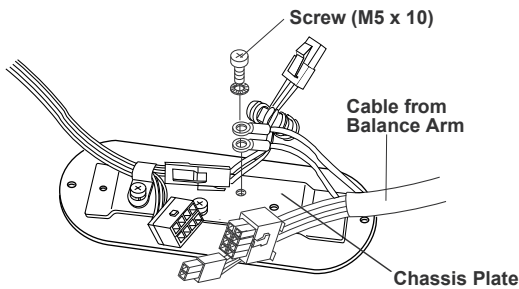
## G. BALANCE ARM ASSEMBLY

### ⚠ WARNING

**Do not release Arm holding band until the X-ray head has been installed.**  
**Balance arm assembly is spring loaded and can cause equipment damage and injury if not handled in the proper manner.**

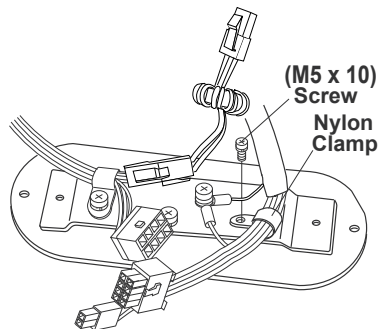
1. During this procedure, do not remove Arm holding band.
2. Remove two (M3 x 8mm) screws from the underside of the horizontal arm to open the bottom cover. (Fig.3-11)
3. Route the cable with 2P and 8P connectors from the balance arm shaft through the horizontal arm. Insert the balance arm into the horizontal arm. The cable should be fed through the bottom cover opening on the bottom of the horizontal arm. (Fig.3-12)
4. Secure 2 wires (Grounded wires) together with the (M5 x 10mm) screw on the bottom cover. (Fig.3-13A)

Note : Two ring terminals should not protrude from a chassis plate. (Fig.3-13A)

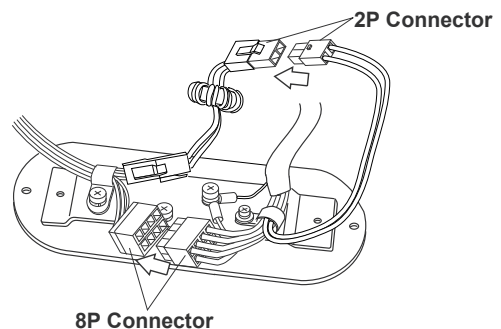


**Fig.3-13A** Attaching Grounded Wires on Bottom Cover

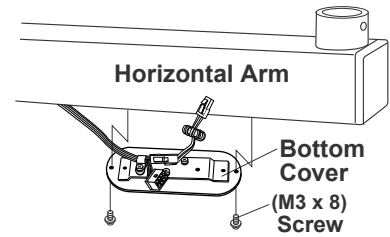
5. Secure the wires from the balance arm to the bottom cover with the nylon cable clamp to prevent damage from twisting. (Fig.3-13B) Then connect the 2P and 8P connectors. (Fig.3-13C)
6. Re-attach the bottom cover to the horizontal arm with two screws. (Fig.3-12)



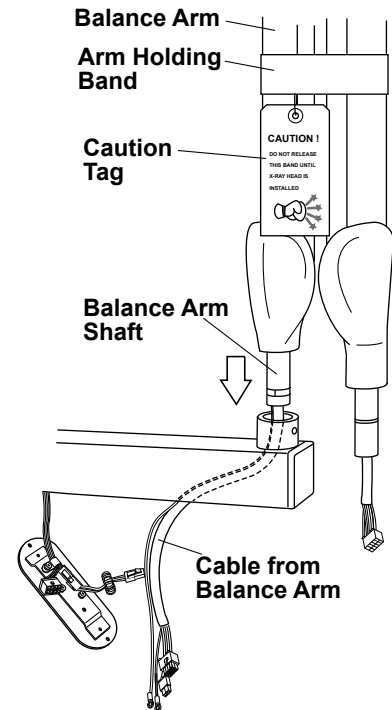
**Fig.3-13B** Attaching Balance Arm Cable on Bottom Cover



**Fig.3-13C** Connection of Connectors on Bottom Cover



**Fig.3-11** Horizontal Arm Bottom Cover

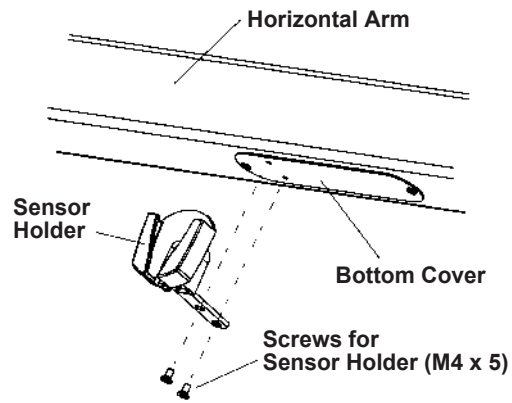


**Fig.3-12** Balance Arm Installation

- Attach a sensor holder to a bottom cover of the horizontal arm with 2 countersunk screws (M4 x 5). (Fig.3-14A)

**⚠ CAUTION**

- Sensor holder can be mounted to left or right of horizontal arm. Set at convenient direction.
- Sensor holder is for holding a digital sensor. Do not use a sensor holder for other purpose.



**Fig.3-14A** Sensor holder

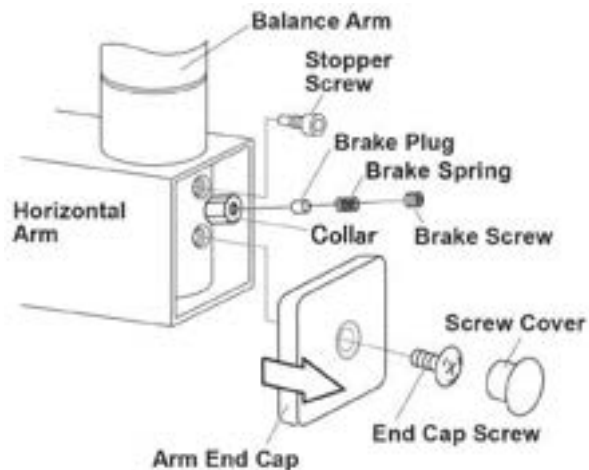
- Remove the arm end cap from horizontal arm. Insert the stopper screw into upper threaded hole inside horizontal arm and tighten securely. (Fig. 3-14B)

**⚠ CAUTION**

**If stopper screw is not tightened securely, the Balance Arm can lift out of the horizontal arm.**

- Insert the brake plug, brake spring and brake screw into the horizontal arm collar. (Fig. 3-14B) Do not fully tighten.

- Set the arm end cap at the original place and fix it with end cap screw. Put the screw cover on it. (Fig.3-14B)



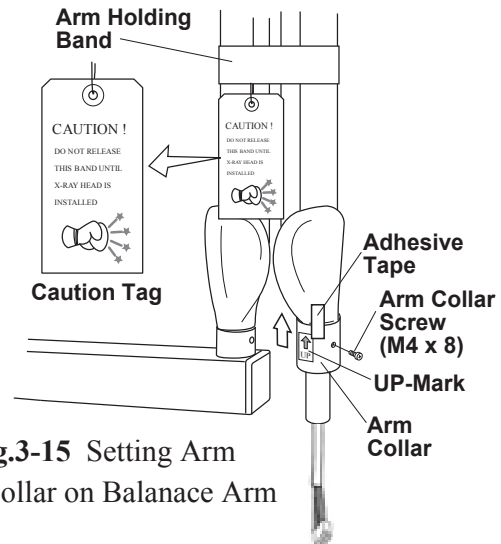
**Fig.3-14B** Attaching Balance Arm to Horizontal Arm

**[ 4 ] HEAD ASSEMBLY INSTALLATION**

**⚠ WARNING**

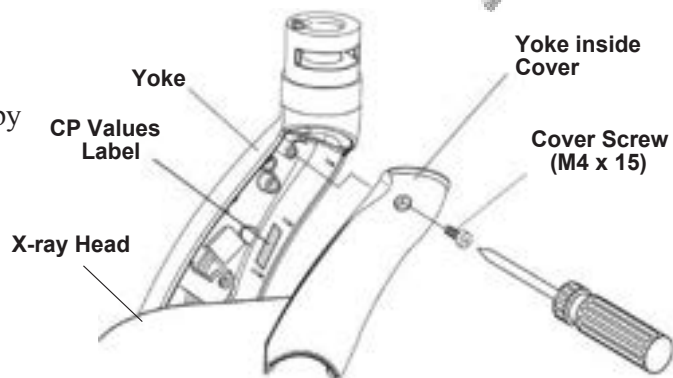
**Do not release Arm holding band until the X-ray head has been installed. Balance arm assembly is spring loaded and can cause equipment damage and injury if not handled in the proper manner. Refer to the Caution Tag on the band.**

- Remove the arm collar screw (M4 x 8mm) from the arm collar. Slide the arm collar upward and temporarily hold it in position with adhesive tape. (Fig.3-15)



**Fig.3-15** Setting Arm Collar on Balance Arm

- Open the yoke inside cover of x-ray head by removing (M4 x15mm) cover screw. (Fig.3-16)



**Fig.3-16** Removing Yoke Inside Cover

3. Making sure the stopper ring is placed on the yoke, insert the wiring from the balance arm assembly through the head shaft and into the yoke. (Fig.3-17)

4. Insert the shaft of the balance arm into the head yoke, and while holding the head in position, insert the head key securely into the retaining groove. (Fig.3-17)

5. Remove adhesive tape and slide the arm collar downward. Fix it in place with the arm collar screw. Remove the UP-mark from the arm collar. (Fig.3-17)

6. Loosen the (M5 x 10mm) screw and remove the nylon cable clamp from the yoke housing. Place cable clamp on the balance arm cable. Connect the 10P connectors, and then attach the balance arm cable to the yoke housing with the nylon cable clamp. (Fig.3-18)

7. Reattach the yoke inside cover with the screw (M4 x 15mm). Before closing the cover, note the CP values on the CP values label inside of the yoke. (Fig.3-16)

8. Remove arm holding band.

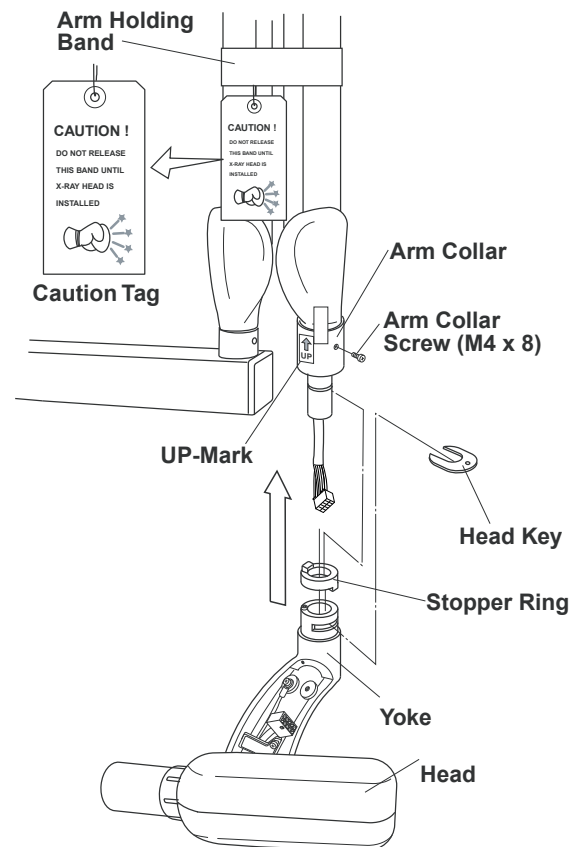


Fig.3-17 X-ray Head Installation

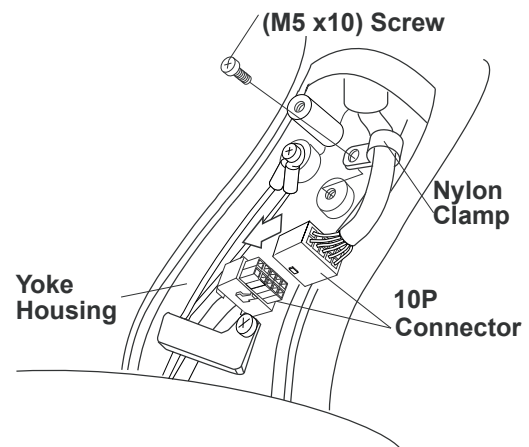


Fig.3-18 Connection 10P Connector in Yoke

## [ 5 ] SUB CONTROLLER INSTALLATION

The wall and the strength of the hardware used must be checked and verified as being adequate to withstand a 10 pound (4.5kg) shear load. A flush mounted junction box with the necessary conduit and wiring should be pre-installed at 56" (1420mm) from the floor.

### ⚠ CAUTION

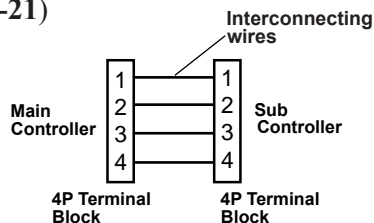
**Do not peel off the film from LCD screen until whole installation is completed.**

1. Remove two (M3 x8mm) screws from the under side of the controller and open the front panel. (Fig.3-19)
2. Disconnect the 4P connector from the timer PC Board. (Fig.3-20)
3. Route the interconnecting wires from the main controller through access hole of chassis and mount on the wall with four (ø4.1 x 20mm) wood screws. (Fig.3-20)

### ⚠ CAUTION

**If subcontroller is mounted on the front panel of main controller, use four (M3 x 6 mm) screws supplied instead of wood screws.**

4. Cut 4 interconnecting wires from main controller to a workable length. Strip 3/16" insulation off the wires and connect them to the 4P terminal block. Terminal number for each wire should be matched to the terminal number in the main controller. (Fig.3-21)



### ⚠ CAUTION

**Miswiring causes permanent damage to both timer PC board and power PC board.**

5. If wire length is too long, push it back into the access hole of the wall. This will prevent mechanical damage to the timer PC Board when replacing the front cover.
6. Reattach the 4P connector to the timer PC Board. (Fig.3-20)
7. Set the pins located on the upper side of the front panel into holes on the top of chassis and attach the front cover to the chassis with two (M3 x 8mm) screws. (Fig.3-19 & Fig.3-22)

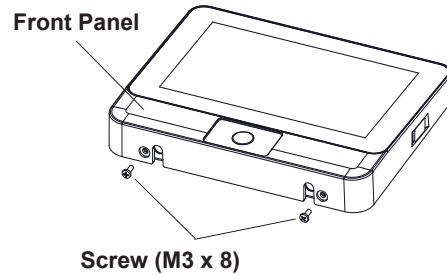


Fig.3-19 Opening Front Panel

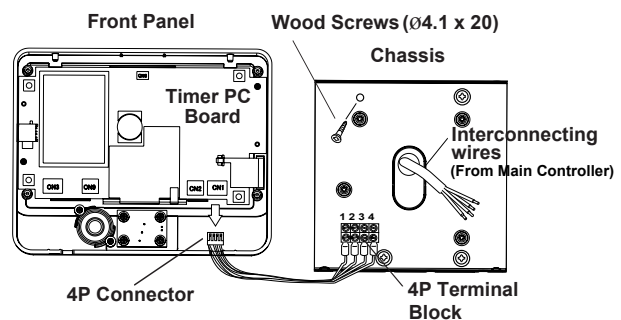


Fig.3-20 Attaching Sub Controller Chassis

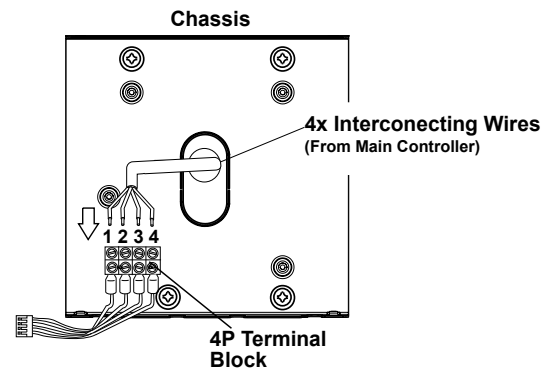


Fig.3-21 Interconnecting Wires Connection in Sub Controller

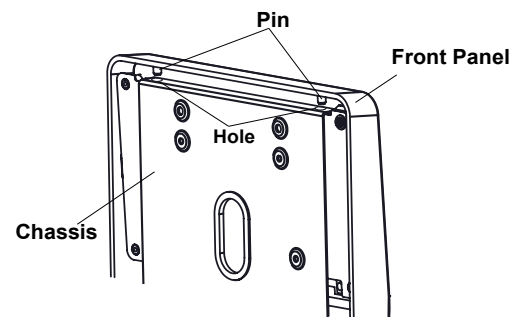


Fig.3-22 Upper side of Sub Controller

## [ 6 ] HAND EXPOSURE SWITCH (OPTION)

An optional hand exposure switch can be connected to the sub controller. Since this exposure switch has a coiled cord, operator can stand the most suitable position for operation.

The exposure switch on the front panel of sub controller and this hand exposure switch can be used. If local code prohibits use of both switches, disconnect the connector of either one of the switches.

1. Confirm the hand exposure switch kit contains: a hand exposure switch, two adapter cables, a hook and a screw for hook (M3 x10mm). (Fig.3-23)
2. Connect the red adapter cable (longer cable) to the connector of the hand exposure switch. (Fig.3-23)
3. Remove two (M3 x8mm) screws from the under side of the controller and open the front panel.
4. Connect the connector at the end of adapter cable (red wires) to CN3 connector on the LCD PC board. (Fig.3-24)
5. Insert the bushing of coil cord into the slot at the bottom of the chassis, reattach the front cover and secure it with one of original screws (M3 x 8mm) at the opposite side of hand switch cord. (Fig.3-24)
6. Place the hook next to the hand switch cord on the bottom of front cover and attach it with countersunk screw (M3 x 10mm) supplied with hook. (Fig.3-25)

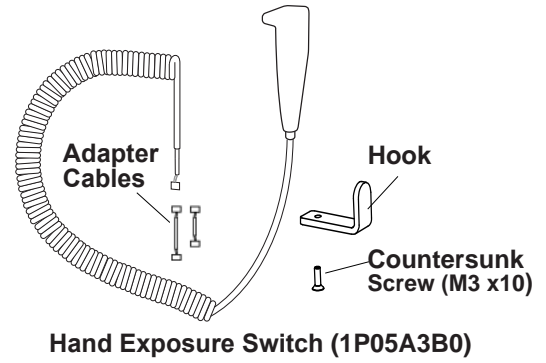


Fig.3-23 Hand Exposure Switch Kit

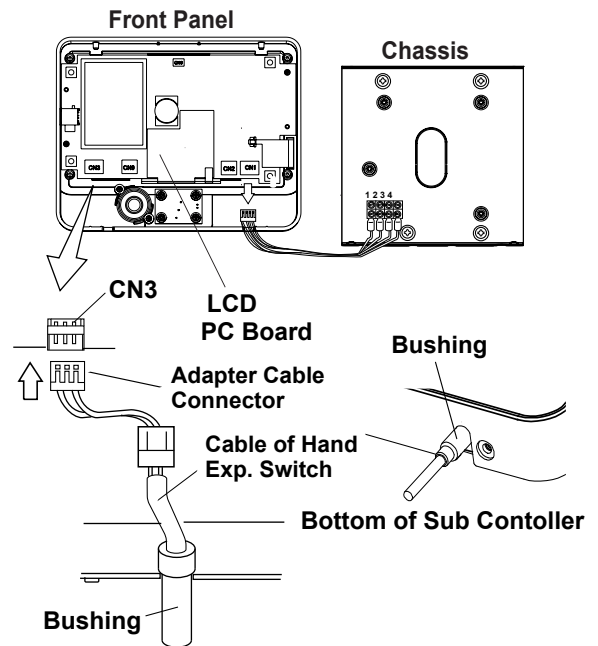


Fig.3-24 Connecting Hand Exposure Switch

## [ 7 ] EXTERNAL INTERLOCKS (NOT SUPPLIED)

If the external interlock for preventing from starting to emit x-radiation or to stop emitting x-radiation is used, the interlock switch should be inserted in #3 terminal of 4P terminal block either in the main controller or in the sub controller. If this interlock switch is opened, emission will be stopped. It is recommended to indicate the state of this interlock switch. (Fig.3-26)

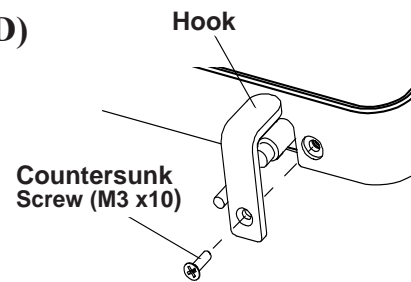


Fig.3-25 Installation of Hook for Hand exposure Switch

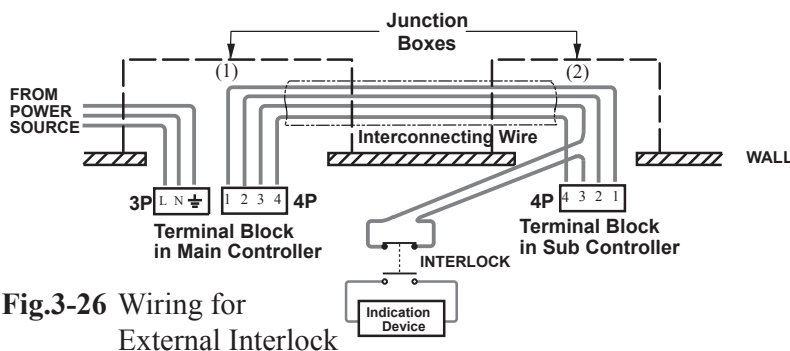


Fig.3-26 Wiring for External Interlock

## SECTION 4 : POST INSTALLATION INSPECTION

### [ 1 ] ARM ASSEMBLY

1. Incorrect leveling of the wall plate and arm bracket can cause arm drift. First, check leveling with horizontal arm in position #1. (Fig.4-1) If not correct, bracket must be adjusted by placing shims between the arm bracket and wall plate. (Refer to page 9.)

#### IMPORTANT :

If the end of the horizontal arm shown in position #1 is pitched below level, then the tube head will drift away from the wall. If the end of the horizontal arm in position #1 is pitched above level, then the arm will require only minimum adjustment of the brake screw. (Fig.3-14B)

2. Swing the horizontal arm to the far right end and far left end and check that the positive degrees at each location are equal. If those are not equal, adjust the arm mounting bracket as follows. (Fig.4-1)
  - a. Slightly loosen two top mounting bolts for arm mounting bracket.
  - b. Shift the bracket left or right until the positive degrees of the arm at each location become equal.
  - c. Move the horizontal arm to position # 1.
  - d. Fully tighten two top mounting bolts.
  - e. Fully tighten bottom mounting bolt.

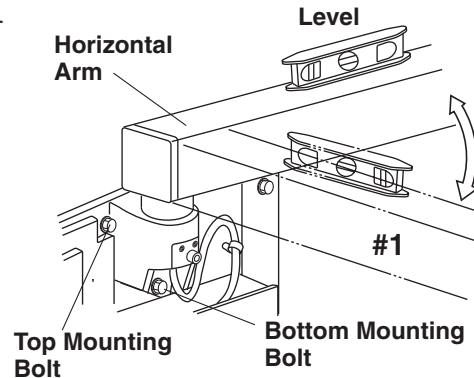


Fig.4-1 Horizontal Arm Adjustment

**NOTE :** Slight tendencies to drift can be corrected by tightening brake screw in horizontal arm. Do not tighten beyond what is required to prevent drift.

### [ 2 ] BALANCE ARM TENSION ADJUSTMENT

1. Place the balance arm assembly into position.
2. If either balance arm drifts higher or lower from the set position, remove the spring adjuster cover and adjust the balance arm spring tension with the balance arm wrench supplied. (Fig.4-2)

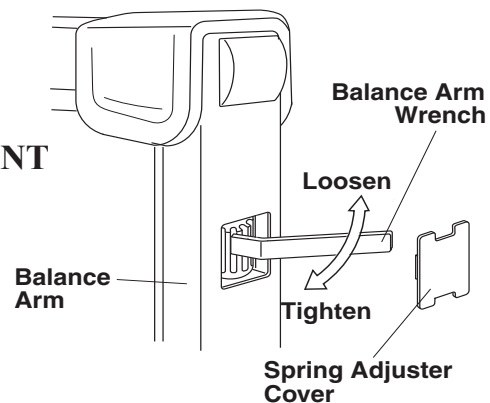


Fig.4-2 Balance Arm Tension Adjustment

### [ 3 ] HEAD POSITIONING

- A. Place head into position.
- B. If head drifts from the set position, adjust the brake screws according to the following procedures. (Fig.4-3)
  1. Loosen the yoke side cap screw (ø3 x 8mm tapping screw) and remove the yoke side cap.
  2. Adjust the six brake screws using a screw driver.
  3. After adjustment, reattach the yoke side cap and screw.

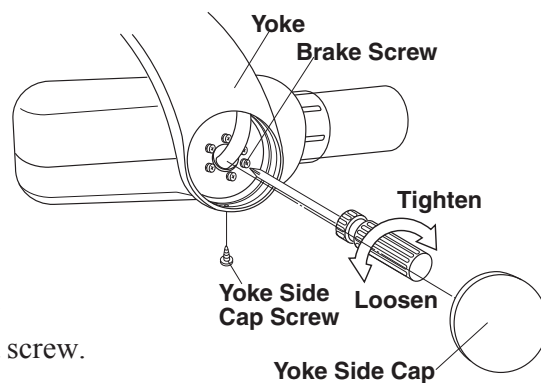


Fig.4-3 Head Positioning

#### [ 4 ] CONFIRMATION OF POWER SUPPLY VOLTAGE

As specified in Electrical Requirements (page 5), power supply voltage must be within the operable range of 108 ~ 132 VAC. Confirm the power supply voltage again before turning on the unit.

1. Open the front panel of main controller by loosening two screws on top of the controller.
2. Set the range of digital multimeter at 200 VAC, connect probes of multimeter to L and N of the 3P terminal block.

#### WARNING

**Do not touch the restriction plate (refer to Fig.3-3) with the probes of multimeter during measurement, or a short circuit occurs.**

3. Confirm that the reading is 120V±10% (108 ~ 132 VAC).

NOTE : The PHOT-XIIs Model 505 x-ray can not be operated unless the power supply voltage is within this range.

#### [ 5 ] INITIAL SETTING AND CONFIRMATION AFTER POWER ON

If power supply voltage is confirmed to be within the range, power can be ON. But before turning ON, please read SECTION 5 and understand the operation procedures.

When turning on the power switch at the first time after the factory shipment, a message asking for initial setup appears. If "YES" is selected, instructions for the following 2-1 to 2-7 will be displayed. If setup is finished according to the screen, this message will not appear again when the power switch is turned on later. If all setup is not finished or "NO" is selected, same message will be displayed every time when the power switch is turned on until initial setup is completed.



##### 5-1. CLOCK SETTING

For north america you can set the clock by selecting the area, if it is the first time to set after shipment. (When we ship the controller, clock is set at Japanese time. If you select the area, clock is changed according to the time difference between Japan and that selected area.)

For all earea including north america, you can set the clock by entering year, month, day, hour and minute manually.

##### 5-2. CONFIRMATION OF TUBE VOLTAGE COMPENSATION VALUE

Tube voltage is kept to be constant and same as the specified value by the feed-back control system. High voltage is converted into low voltage feed back signal by the voltage divider in the tube head. The precision of tube voltage depends on the accuracy of this voltage divider, although each divider has little deviation. To compensate this deviation, the compensation values for each tube head are defined and written on the label in the tube head yoke. Before making an exposure, check these values to be same as the values stored in the subcontroller.

1. Confirm the tube voltage compensation (CP) values for 60kV and for 70kV written on the label affixed inside of the head yoke.
2. Confirm the values on the LCD screen are same as the values on the label. If those are same, touch the store button. If different, adjust the values on LCD screen  or  button, and touch the store button.

### 5-3. CALIBRATION OF TUBE CURRENT (mA)

The PHOT-XIIs Model 505 x-ray incorporates self diagnose and adjusting system to check if the tube current are within specified ranges at the beginning of exposure.

1. Point the x-ray head away from all personnel.
2. Press the exposure switch according to the instructions on the LCD screen.

 **WARNING**

**X-radiation is generated for 0.01, 0.1 or 0.5 seconds.**

3. By several exposures the adjustment value for tube current becomes optimum value.
4. If the adjustment is finished for 3mA and 6mA, OK will be appeared. Please touch OK button.

### 5-4. PRIORITY OF SELECTIONS AT POWER ON

Factory default settings are

- kV selection : 60 kV
- mA selection : 6 mA
- Image receptor : Digital sensor
- Patient type : Adult
- Cone type : Short cone (round)

If necessary, these settings can be changed. For example, in case of pedodontistry, patient type should be changed to Child. For the image receptor, as the sensitivity of each receptor is different, please set the sensitivity according to section 11 on page 23.

### 5-5. CONFIRMATION OF kV AND mA

1. Point the x-ray head away from all personnel.
2. Turn the main switch on and set the exposure time at 1 sec. and 60 kV, 3 mA.
3. Make an exposure and keep the exposure switch depressed continuously after the exposure is over.

 **WARNING**

**X-radiation is generated for 1 second.**

4. Keeping the exposure switch depressed, touch kV or mA selection switch. kV and mA measured values will be displayed on the LCD screen.
5. Confirm the values at steady portion are 60±5 kV and 3±1 mA.
6. Release the exposure switch and change the setting to 70 kV, 6 mA.
7. Make an exposure and keep the exposure switch depressed continuously after the exposure is over.
8. Keeping the exposure switch depressed, touch kV or mA selection switch. kV and mA measured value will be displayed on the LED screen.
9. Confirm the values at steady portion are 70±5 kV and 6±1 mA.

## 5-6. CONFIRMATION OF EXPOSURE WARNING LIGHT & BUZZER

### A. EXPOSURE WARNING BUZZER

1. Make an exposure and confirm that the exposure warning sound is activated during the entire exposure.

### B. EXPOSURE WARNING INDICATION

1. Make an exposure and confirm that the exposure warning indication appears on LCD screen during the entire exposure.

## 5-7. CONFIRMATION OF LINE VOLTAGE REGULATION

1. Make sure that main power switch is "OFF".
2. Set the range of digital multimeter at 200 VAC, connect probes of multimeter to L and N of the 3P terminal block in the main controller.

 **WARNING**

**Do not touch the restriction plate (refer to Fig.3-3) with the probes of multimeter during measurement, or a short circuit occurs.**

3. Turn the main power switch on, and set the exposure time at 2.00 sec. with manual switch at 70kV, 6mA.
4. Record the no-load line voltage (VN) indicated by the multimeter before exposure.
5. Make an exposure and record the load voltage (VL) indicated by the multimeter during exposure.

 **WARNING**

**X-Radiation is generated for 2 seconds.**

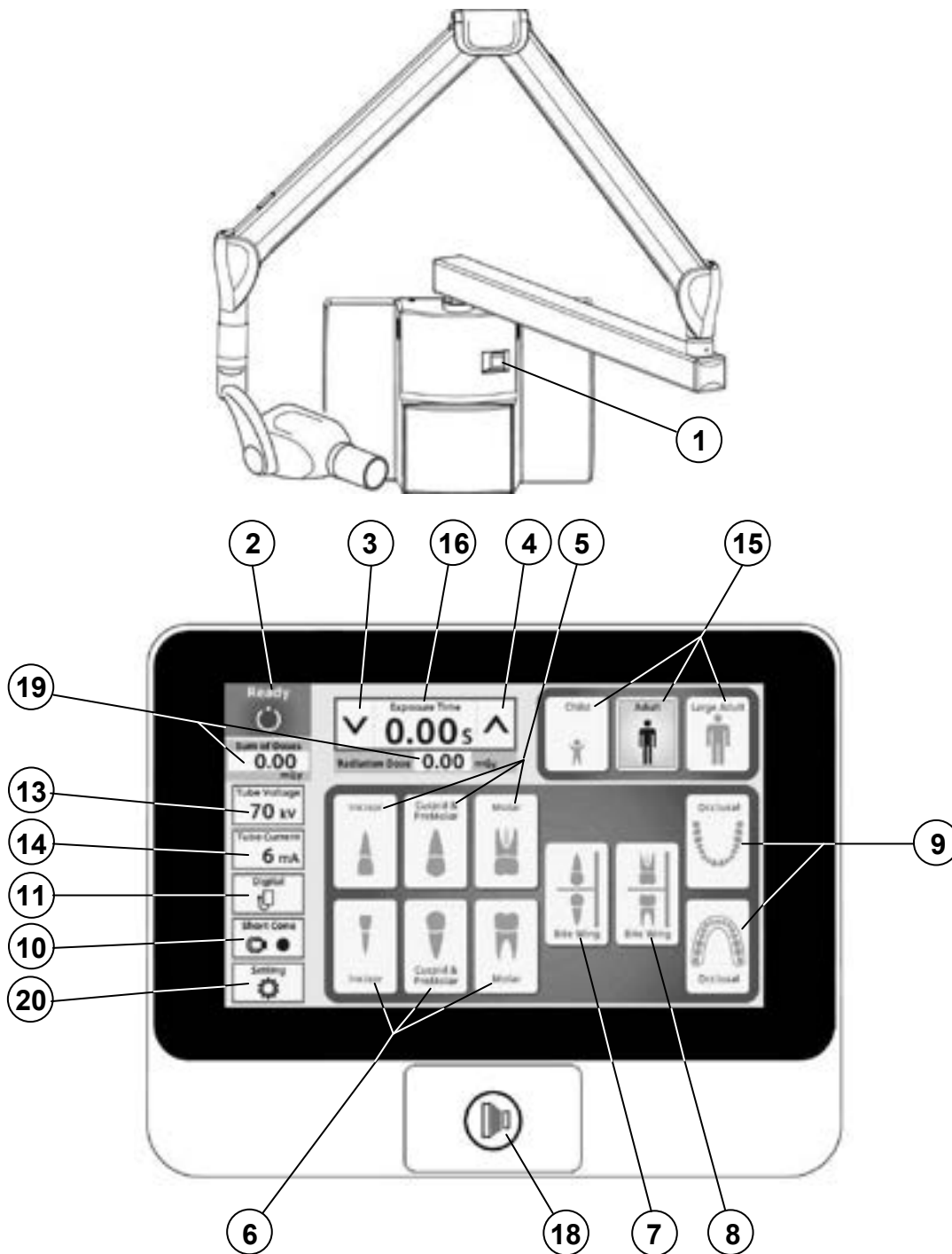
**NOTE :** Read the multimeter when the value is stabilized (about one second after exposure started).

6. Calculate line voltage regulation R(%) by the formula below

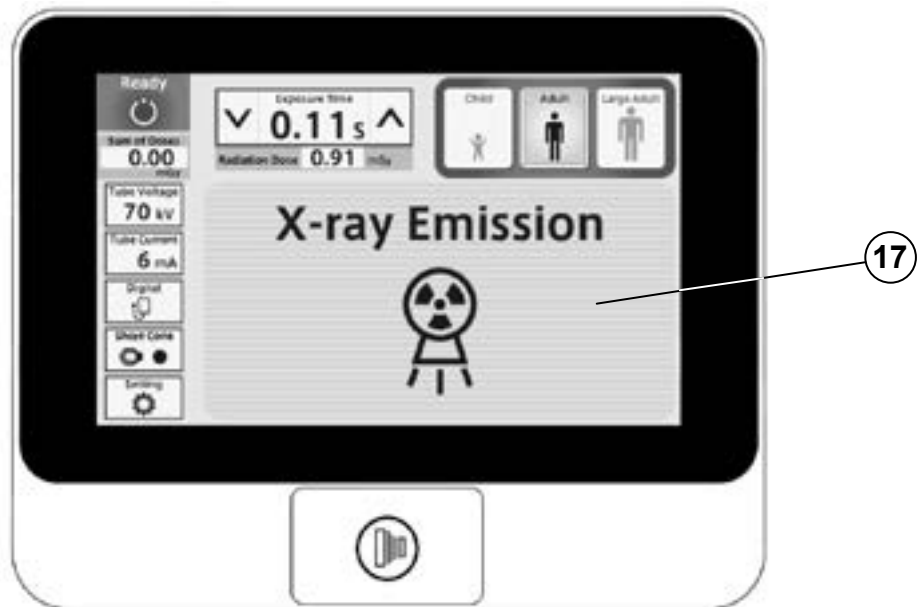
$$R = \frac{VN - VL}{VL} \times 100$$

**NOTE :** Line voltage regulation must not exceed the range of 0 ~ 5 %. If it is greater than 5%, the size of the power supply wires must be increased. Refer to the power supply requirements outlined on page 5 to determine the correct wire size necessary. If line voltage regulation is within the range, apparent resistance of supply line can be considered to be less than 0.5 OHM.

**SECTION 5 : CONTROL IDENTIFICATION AND OPERATION**  
**[ 1 ] MAJOR COMPONENTS AND CONTROL IDENTIFICATION**



- |  |  |
|--|--|
| ① Main Power Switch                        | ⑪ Image Receptor Selection Switch                |
| ② Ready Indication                         | ⑫ is intentionally omitted                       |
| ③ Exposure Time Adjustment Switch (Down)   | ⑬ kV Selection Switch                            |
| ④ Exposure Time Adjustment Switch (Up)     | ⑭ mA Selection Switch                            |
| ⑤ Tooth Selection Switch (Maxilla)         | ⑮ Patient Size Selection Switch                  |
| ⑥ Tooth Selection Switch (Mandible)        | ⑯ Exposure Time Display Window                   |
| ⑦ Tooth Selection Switch (Bitewing)        | ⑰ Exposure Warning Indication (on the next page) |
| ⑧ Tooth Selection Switch (Bitewing Molars) | ⑱ Exposure Switch                                |
| ⑨ Tooth Selection Switch (Occlusal)        | ⑲ Radiation Dose Indication                      |
| ⑩ Cone Type Selection Switch               | ⑳ Setting Mode Switch                            |



## [ 2 ] FUNCTION OF CONTROLS



### ① Main Power Switch

Pushing the upper side of this switch to the ON position energizes the x-ray unit.

### ② Ready Indication

This indication becomes green when the exposure time is set and the line voltage is within operable range (108 ~ 132Vac). When this indication is white, exposure cannot be made.

### ③④ Exposure Time Adjusting Switches

By momentarily touching the  (or ) switch, the exposure time displayed increases (or decreases) by one increment. By keeping the switch touched more than 2 sec., the exposure time displayed increases (or decreases) continuously until the switch is released. PHOT-X IIs Model 505 has the following 37 exposure time settings:

0.00, 0.01, 0.02, 0.03, 0.04, 0.05, 0.06, 0.07, 0.08, 0.09, 0.10, 0.11, 0.13, 0.14, 0.16, 0.18, 0.20, 0.22, 0.25, 0.28, 0.32, 0.36, 0.40, 0.45, 0.50, 0.56, 0.63, 0.71, 0.80, 0.90, 1.00, 1.12, 1.25, 1.40, 1.60, 1.80, 2.00 (sec.)

### ⑤~⑨ Tooth Selection Switches

Touching one of these switches sets the exposure time to the optimum value according to the tooth type and the following settings (⑩~⑮). Selected tooth is illuminated in orange.

⑤ Maxilla : Incisor, Cuspid & Premolar or Molar

⑥ Mandible : Incisor, Cuspid & Premolar or Molar

⑦ Bitewing : Incisor and Cuspid & Premolar

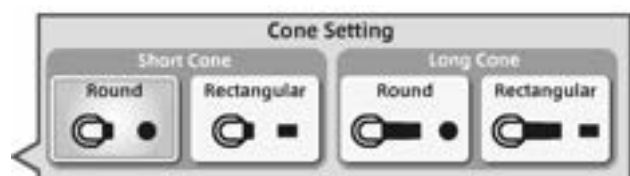
⑧ Bitewing : Molar

⑨ Occlusal : Maxilla and Mandible

If Incisor of Mandible switch is touched more than 3 sec., unit goes into the screen saver mode and touch switch is disabled. To return to normal mode, touch any part on the LCD screen more than 3 sec.

### ⑩ Cone Type Selection Switch

This switch indicates the cone type being selected at the time. Momentarily touching this switch will open the cone type selection window. This window closes when one of cones is selected.



Cone type Selection windows

## ⑪ Image Receptor Selection Switch

To get optimal images the exposure timer adjustment according to the sensitivity of image receptor is important. The PHOT-X IIs has 16 density settings for each three kinds of image receptors, i.e. film, digital sensor and phosphor plate. For film, two different sensitivities can be selected as film-a and film-b and those can be switched easily.



Image Receptor Selection windows

### (1) Film

Following two speed (=sensitivity) settings are pre-set at the factory.

a = Film speed No. F.09 (equivalent to ISO speed group "D", or Kodak Ultra-Speed film)

b = Film speed No. F.05 (equivalent to ISO speed group "F/E", or Kodak InSight film)

Including these two speeds, the PHOT-X IIs Model 505 x-ray can provide 16 different film speeds (F.00 ~ F.15) and any two of them can be programmed as film-a and film-b.

Film speed number being selected at the time can be confirmed by touching switch ⑪.

If doctor uses a different film speed, or prefers darker (or lighter) radiographs, the new speed can be programmed as follows. Larger speed number makes films darker. If film speed number is increased by 1, exposure time becomes 25 % longer. The method to change the film speed setting is as follows.

1. Go to the setting mode by touching the switch ⑳.
2. Select "Image receptor sensitivity setting" at page 2/3 in "Setting mode".
3. If new film is used, select the "Preset setting", select "film-a" or "film-b" and select the manufacturer and model name of the film.
4. If darker (or lighter) radiographs are preferred or film name is not listed in "Preset setting", select the "Manual setting" and by touching Ⓐ or Ⓑ switch, increase or decrease film speed until the desired number is displayed. Touch the memory icon to store the setting.

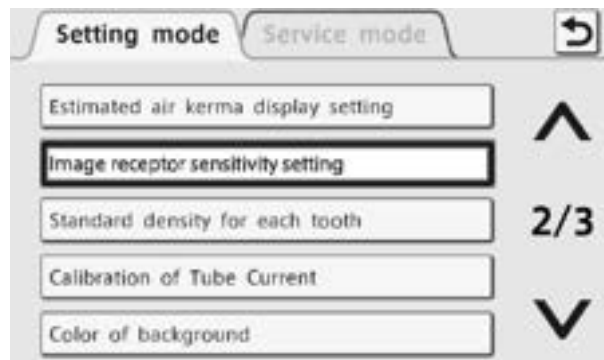
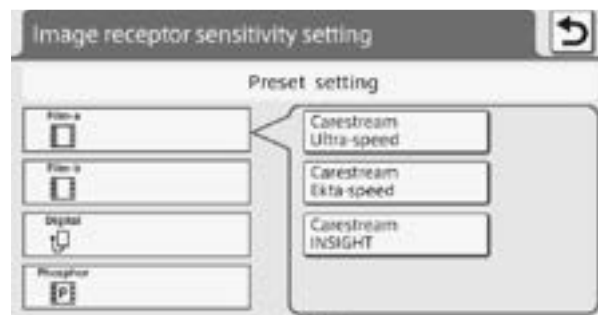


Image Receptor sensitivity setting

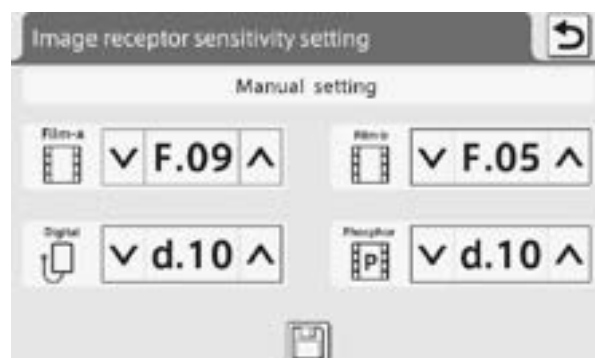
### (2) Digital sensor and Phosphor Plate

If a digital imaging system is used, shorter exposure time is often required compared with film. PHOT-X IIs has 16 speeds for digital sensor and phosphor plate (d.00 ~ d.15).

Factory settings for digital sensor and phosphor plate are both d.10, but it is necessary to change according to the sensitivity of each model of digital sensor or phosphor plate. The density number selected can be checked by touching switch ⑪. The method to change the density setting for digital sensors or phosphor plate is same as film.



Preset setting mode



Manual setting mode

**TABLE 1. Speed Setting and Exposure Time (Short Cone)** [unit : sec.]

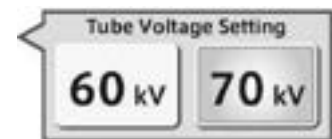
Speed Setting	kV	mA	Child					Adult					Large Adult				
			T1	T2	T3	T4	T5	T1	T2	T3	T4	T5	T1	T2	T3	T4	T5
F. 09	60	3	0.20	0.25	0.28	0.32	0.50	0.32	0.40	0.50	0.56	0.80	0.40	0.50	0.63	0.71	1.00
		6	0.10	0.11	0.14	0.16	0.25	0.16	0.20	0.25	0.28	0.40	0.20	0.25	0.28	0.36	0.50
	70	3	0.14	0.16	0.20	0.22	0.36	0.25	0.28	0.36	0.40	0.56	0.28	0.36	0.45	0.50	0.71
		6	0.07	0.08	0.10	0.11	0.18	0.11	0.14	0.18	0.20	0.28	0.14	0.18	0.22	0.25	0.36
F. 05	60	3	0.08	0.10	0.11	0.14	0.20	0.14	0.16	0.20	0.22	0.32	0.18	0.20	0.25	0.28	0.40
		6	0.04	0.05	0.06	0.07	0.10	0.07	0.08	0.10	0.11	0.16	0.09	0.10	0.13	0.14	0.20
	70	3	0.06	0.07	0.08	0.10	0.14	0.10	0.11	0.14	0.16	0.25	0.13	0.14	0.18	0.20	0.28
		6	0.03	0.04	0.04	0.05	0.07	0.05	0.06	0.07	0.08	0.11	0.06	0.07	0.09	0.10	0.14
d.10	60	3	0.13	0.14	0.18	0.20	0.28	0.20	0.25	0.28	0.36	0.50	0.25	0.32	0.36	0.40	0.63
		6	0.06	0.07	0.09	0.10	0.14	0.10	0.13	0.14	0.16	0.25	0.13	0.16	0.18	0.22	0.32
	70	3	0.09	0.11	0.13	0.14	0.22	0.14	0.18	0.22	0.25	0.36	0.18	0.22	0.25	0.32	0.45
		6	0.04	0.05	0.06	0.07	0.11	0.07	0.09	0.11	0.13	0.18	0.09	0.11	0.13	0.16	0.22

**TABLE 2. Speed Setting and Exposure Time (Long Cone)** [unit : sec.]

Speed Setting	kV	mA	Child					Adult					Large Adult				
			T1	T2	T3	T4	T5	T1	T2	T3	T4	T5	T1	T2	T3	T4	T5
F. 09	60	3	0.40	0.50	0.63	0.71	1.00	0.71	0.80	1.00	1.12	1.60	0.90	1.00	1.25	1.40	2.00
		6	0.20	0.25	0.28	0.36	0.50	0.36	0.40	0.50	0.56	0.80	0.45	0.50	0.63	0.71	1.00
	70	3	0.28	0.36	0.45	0.50	0.71	0.50	0.56	0.71	0.80	1.25	0.63	0.71	0.90	1.00	1.40
		6	0.14	0.18	0.22	0.25	0.36	0.25	0.28	0.36	0.40	0.56	0.32	0.36	0.45	0.50	0.71
F. 05	60	3	0.18	0.20	0.25	0.28	0.40	0.28	0.36	0.40	0.45	0.71	0.36	0.45	0.50	0.56	0.90
		6	0.09	0.10	0.13	0.14	0.20	0.14	0.18	0.20	0.25	0.36	0.18	0.22	0.25	0.28	0.45
	70	3	0.13	0.14	0.18	0.20	0.28	0.20	0.25	0.28	0.32	0.50	0.25	0.32	0.36	0.40	0.63
		6	0.06	0.07	0.09	0.10	0.14	0.10	0.13	0.14	0.16	0.25	0.13	0.16	0.18	0.22	0.32
d.10	60	3	0.25	0.32	0.36	0.45	0.63	0.45	0.50	0.63	0.71	1.00	0.56	0.63	0.80	0.90	1.25
		6	0.13	0.16	0.18	0.22	0.32	0.22	0.25	0.32	0.36	0.50	0.28	0.32	0.40	0.45	0.63
	70	3	0.18	0.22	0.28	0.32	0.45	0.32	0.36	0.45	0.50	0.71	0.40	0.45	0.56	0.63	0.90
		6	0.09	0.11	0.13	0.16	0.22	0.16	0.18	0.22	0.25	0.36	0.20	0.22	0.28	0.32	0.45

**⑬ kV Selection Switch**

Momentarily touching this switch will open the kV selection window. This window closes when either 60 or 70 kV is selected.



KV Selection Window

**⑭ mA Selection Switch**

Momentarily touching this switch will open the mA selection window. This window closes when either 3 or 6 mA is selected.



mA Selection Window

**⑮ Patient Selection Switch**

These switches alter the selection of patient type/size to be radiographed (child, adult or large adult) and sets the exposure time automatically. If the weight of child is less than 20kg, touch switch once after setting to child. If the weight of child is over 50kg and less than 70kg, touch switch twice after setting to child. If the weight of child is over 70kg, set to adult.

**NOTE: Setting or adjusting the exposure time manually (with or switch) supersedes ⑤ ~ ⑮ functions.**

**⑯ Exposure Time Display Window**

This window displays the selected exposure time.

**⑰ Exposure Warning Indication**

This indication appears while the unit is producing x-radiation.

**⑱ Exposure Switch**

This switch initiates radiographic exposure. When making an exposure, depress and hold this switch until the Exposure Warning Indication ⑰ and the audible warning shut off. Failure to keep this switch depressed will result in the premature termination of the exposure and an error code E.00 will be displayed.

## ①⑨ Radiation Dose Indication

Estimated air kerma (radiation dose) at distal end of cone can be displayed below the exposure time display window. This value is calculated by kV, mA, exposure time and cone type selected at the moment. The value displayed below the ready indication is sum of estimated air kerma of each exposure after the power switch has been turned on.

The units of these values can be selected from mGy or mGycm<sup>2</sup>. And also to display these values or not can be selected by the following procedures.

1. Go to the setting mode by touching switch ②⑩.
2. Select “Estimated air kerma display setting” at 2/3 page of setting mode.
3. Select “Display ON” or “Display OFF”.
4. If “Display ON” is selected, you can select “mGy” or “mGycm<sup>2</sup>” on next menu.

## ②⑩ Setting Mode Switch

By touching this switch the normal operation mode will be changed to the setting mode or service mode. At the setting mode, following settings can be changed. Refer to section [5] for detail. Service mode is restricted to the qualified dealer service personnel and requires password.

Page 1/3: Parameter selection at power ON

- Volume control
- Brightness of LCD
- Sensitivity of touch panel
- Language selection

Page 2/3: Estimated air kerma display setting

- Image receptor sensitivity setting
- Standard density for each tooth
- Calibration of tube current
- Color of background

Page 3/3: Screen saver setting

- Nameplate setting
- Photo display setting

### [ 3 ] OPERATING PROCEDURES

1. Turn ON the Main Power Switch (1).

**NOTE : Do not turn on the main power switch while touching the LCD screen, as the touch sensor initializes the sensitivity when the power is turned on.**

2. Select the appropriate tooth type ((5) ~ (9)), and confirm the pre-selected conditions (cone type, film or digital, kV, mA and patient size) are suitable for exposure.

**NOTE : To manually set the exposure time, depress either of the Manual Exposure Time Adjusting Switches (▲ or ▼) until the desired exposure time appears in the Exposure Time Display Window (16). While the unit is in manual mode, other selection switches ((5) ~ (15)) do not affect exposure time. (All of the tooth selection switches are white.) To return to the automatic exposure time selection mode, depress any one of Tooth Selection Switches ((5) ~ (9)).**

3. Confirm that Ready Indication (2) is illuminated on green.

**NOTE : The ready indication will not illuminate unless the incoming line voltage is correct and within the x-ray's operable range (108 ~ 132Vac).**

4. Set the image receptor in the patient's mouth and position the x-ray tubehead using the standard positioning procedures.

5. Depress the Exposure Switch (18). When the Exposure Switch is depressed, the Exp. Warning Indication (17) appears and the audible warning sounds. Do not release the Exposure Switch until the Exposure Warning Indication and audible warning automatically shut off. Failure to keep the switch depressed will result in exposure being terminated prematurely.

6. To continue to radiograph other teeth, just select appropriate Tooth Selection Switches ((5) ~ (9)).

**IMPORTANT : To protect x-ray tube head from heat accumulation, wait for a time interval that is equal to 30 times the selected exposure time before making additional exposures. (Example : a 15 sec. wait is necessary between exposures that are 0.5 sec. in duration.)**

7. Turn OFF the Main Power Switch (1) in order to prevent accidental exposures when the unit is not in use.

**NOTE : If the unit is left without being operated and the Main Power Switch (1) is kept on, display will go into one of the following four screen saver modes.**

- a. Energy saving mode
- b. Fixed display of one photo
- c. Slide-show of photos
- d. Nameplate display

**Transition time to the screen saver mode can be set by 5-minute steps and making switch enable or disable during screen saver mode is also selectable.**

### [ 4 ] OPTIONAL HAND EXPOSURE SWITCH

An optional hand exposure switch can be connected to the sub controller. Since this exposure switch has a coiled cord, operators can stand in the most suitable position for operation. As controller has separate connector for this exposure switch, both exposure switch (18) on the front panel of sub controller and this hand exposure switch can be used. If local code prohibits use of both, ask installer to disconnect the connector of either switch.

## [ 5 ] SETTING MODE

By touching the setting mode switch at bottom left corner, the normal operation mode can be changed to the setting mode or service mode. There are 13 setting modes and each purposes of those settings are as follows.

### 1. Parameter selection at power ON

Factory default settings are

kV selection : 60 kV

mA selection : 6 mA

Image receptor : Digital sensor

Patient type : Adult

Cone type : Short cone (round)

If necessary, these settings can be changed. For example, in case of pedodontistry, patient type should be changed to Child. For the image receptor, as the sensitivity of each receptor is different, please set the sensitivity as shown page 23.

If the same settings before the power switch is turned off could be set at power on, select "Same Selection before Power OFF".

### 2. Volume control

Volume of touch screen sound and warning sounds can be adjusted separately. One from 9 levels including off setting can be selected for touch screen sound and one from 3 levels for warning sounds. Warning sounds are for exposure warning and error warning.

### 3. Brightness of LCD

Brightness for backlight of LCD display can be selected from 10 levels.

### 4. Sensitivity of touch panel

Sensitivity of touch switch on the panel can be selected from 3 levels.

### 5. Language Selection

Language can be selected from English, French, Spanish or German.

### 6. Estimated air kerma display setting

Whether to display the estimated air kerma (radiation output) or not to display can be selected. If displaying is selected, the unit of the values can be selected from mGy or mGy<sup>cm</sup><sup>2</sup>.

### 7. Image receptor sensitivity setting

Manual setting or preset setting can be selected.

Manual setting: Two film speeds can be selected from 16 speeds as film-a and film-b. One digital sensor sensitivity can be selected from 16 steps and one phosphor plate sensitivity can be selected from 16 steps. Refer to page 23 for detail.

Preset setting: For each 4 types of image receptors, standard sensitivity can be set by selecting the manufacturer and model name of the image receptor.

### 8. Standard density for each tooth

The exposure time ratio between each tooth is preprogrammed. This ratio can be changed by this setting. Exposure time for each tooth can be increased (or decreased) by 4 steps individually. One step increase is corresponding to 25% increase of exposure time.

### 9. Calibration of tube current

Tube current can be adjusted to be the rated value by making several exposures at this mode. This calibration is necessary at the installation and at the annual maintenance checks.

## 10. Color of background

The default color of the back panel at the normal operation mode is blue. This color can be changed to green or pink. And also there are two patterns for pink.

## 11. Screen saver setting

If the unit is left without being operated and the main power switch is kept on, display will go into screen saver mode. You can select one of following four kinds of screen saver modes.

- a. Energy saving mode: Backlight of LCD becomes minimum in this mode.
- b. Fixed display of one photo: One of ten photos pre-stored is displayed. You can overwrite your original photos on the pre-stored photos.
- c. Slide-show of photos: ten photos are displayed in turn continuously.
- d. Nameplate display: Any name within 20 characters with a photo is displayed.

Transition time from normal mode to the screen saver mode can be set to 5 ~ 30 minutes in 5-minute step. Enabling or disabling of touch switch function during screen saver mode is also selectable. If disabling is selected, the operator must hold down any part on the screen for at least 3 seconds to return to normal mode.

## 12. Nameplate setting

Nameplate creation: Four kinds of nameplates can be created and stored. To check the nameplate already created, touch the mountain icon at right side. To modify or create new name, touch the name or “New Name Input” at left side. Maximum 20 characters can be used for the name of nameplate. After the name is fixed, you can use preinstalled photo or your original photo for that nameplate. If you want to use your own photo, USB flash drive (FAT32 format) containing your photo data should be connected to the right side connector of LCD controller. The file name of your photo should be the same as indicated on the screen and data format should be 16 bit or 24 bit BMP with 800 x 400 pixels.

Nameplate selection: One of the nameplates created should be selected for the screen saver mode.

## 13. Photo display setting

Ten photos are pre-stored. One of ten photos is used for “fixed display of one photo” and ten photos are used for “Slide-show of photos” at screen saver mode.

Stored photo can be checked by touching the mountain icon at right side. If you want to store your own photo, touch one of the bar named “FF00” to “FF09”. Connect USB flash drive (FAT32 format) containing your photo data to the right side connector of LCD controller. The file name of your photo should be the same as indicated on the screen and the data format should be 16 bit or 24 bit BMP with 800 x 480 pixels.

## [ 6 ] DISPOSAL

### 1. Disposal of x-ray unit or components

The tube head of this x-ray unit contains the lead for x-ray shield and insulation oil, which is refined mineral oil and does not contain the carcinogenic substances such as PCBs.

CR type coin lithium battery build in the LCD sub-controller contains Perchlorate material.

When disposing the x-ray unit or components, appropriately dispose complying with all current applicable regulations and local codes.

For the coin lithium battery, see [www.dtsc.ca.gov/hazardouswaste/perchlorate](http://www.dtsc.ca.gov/hazardouswaste/perchlorate).

### 2. Disposal of used film and CCD cover

Dispose the used film covers and CCD sensor covers appropriately, according to precedures indicatated by each manufacturer and all current applicable regurations and local codes.

## [ 7 ] ERROR CODES

If an abnormal condition exists in the unit, or a malfunction occurs, an error code, code condition, and the possible solution will be displayed on the LCD screen. Please refer to the table below.

Error Code	Condition	Step to be Taken	Possible Solution
E. 00	Exposure switch was released before exposure termination.	All the tooth selection lights blink. Touch one of the tooth switches.	Release the exposure switch after the exposure warning indication disappears.
E. 01	Exposure switch was pressed within 10 sec. of previous exposure.	A 10 sec. delay is built in between each exposures and 3 sec. delay is built in after the power is on.	There should be a "wait" interval of 30 times the exposure time between successive exposures.
	Exposure time was set and exposure switch was pressed within 3 sec. after the power switch being turned on.		Wait for a minimum 3 sec. after the main power switch is turned on before pressing the exposure switch.
E. 02	Line voltage was less than 90% of rated voltage.	Line voltage should be in the range of $\pm 10\%$ of rated voltage.	If the line voltage is out of range, correct it by using a step up or down transformer of 1.5kVA or more.
E. 03	Line voltage was more than 110% of rated voltage.		
E. 05	Tube current at last portion of exposure was less than 2 mA at 3 mA setting or less than 4.5 mA at 6 mA setting	Turn off the main power switch and wait for approximately 2 min.	Conduct the calibration of tube current described on page 27.
E. 06	Tube current at last portion of exposure was more than 4 mA at 3 mA setting or more than 7.5 mA at 6 mA setting		
E. 07	During the exposure, tube current becomes less than 1.5 mA at 3mA setting or less than 3 mA at 6 mA setting.		
E. 08	During the exposure, tube current becomes more than 14 mA.		
E. 09	Setting for pre-heating time is out of range.		
E. 10	Exposure switch or exposure circuit had been ON, when main power switch is turned on.		
E. 11	Tube current is detected during pre-heating period.		
E. 12	Tube current is detected when main power switch is turned on.	Turn on the main power switch again.	Refer to the service manual.
E. 14	Tube potential at last portion of exposure was less than 50 kV at 60 kV setting or less than 60 kV at 70 kV setting.		
E. 15	Tube Potential at last portion of exposure was more than 70 kV at 60 kV setting.		

Error Code	Condition	Step to be Taken	Possible Solution
E. 16	1. During the exposure, tube potential becomes less than 40 kV at 60 kV setting or less than 50 kV at 70 kV setting. 2. 2P connector between the main power board and arm or between the arm and tube head is disconnected.	Turn off the main power switch and wait for approximately 2 min.	Refer to the service manual.
E. 17	During the exposure, tube potential becomes more than 80 kV.	Turn on the main power switch again.	
E. 18	Excess current was detected in primary circuit of filament transformer.		
E. 19	Excess current was detected in primary circuit of high voltage transformer.		
E. 20	1. Exposure switch was depressed when tube head temperature was over 60°C. 2. 8P connector between the main power board and arm or between the arm and tube head is disconnected.	Wait until the temperature goes down.	
E. 22	Failure of electrical communication between the power PCB and timer PCB.		
E. 23	Some switch had been on, when the main power switch is turned on. (Except the exposure switch.)	Turn off the main power switch and turn on again.	
E.24	The built-in battery has run out.		
No error	Unable to return to the normal mode from the screen saver mode.	Touch the LCD screen more than 3 seconds. If "switches are still enabled" is selected at the screen saver setting in the setting mode, it is not necessary to press for a long time.	

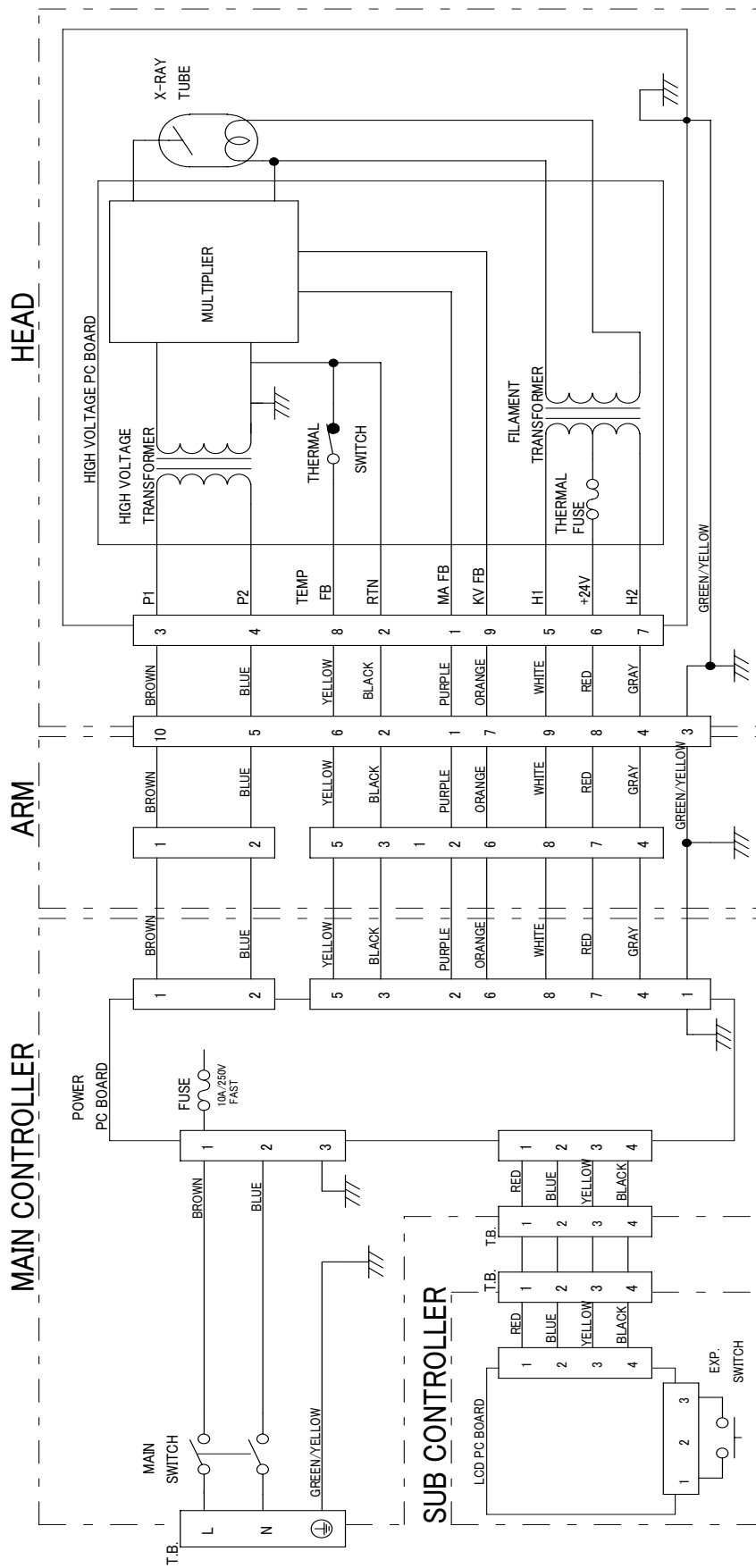
## [ 8 ] MAINTENANCE

The PHOT-X IIs Model 505 x-ray unit requires post installation confirmation and periodic maintenance checks to be performed by dealer service personnel. These procedures ensure that the x-ray unit is functioning within the manufacture's specifications and remains in compliance with the Standard.

It is responsibility of the owner of the unit to see that these maintenance checks are correctly performed.

- a. Maintenance personnel : Qualified dealer service personnel who has the experience with Belmont's x-ray or has been trained by Belmont. But item 7 - 10 of the maintenance check list on Page 32 should be verified routinely by treatment room personnel.
- b. Specification of the parameters to be monitored and monitoring frequency : Refer to the maintenance check list on page 32.
- c. Acceptance limit : Refer to the Maintenance check list on page 32.
- d. Required action when failed : Refer to the Maintenance check list on page 32.
- e. Tools to maintain quality control logs : Use the check list on page 32.
- f. Training material : Operator's instructions, Installation manual and Service manual

# APPENDIX 1 : CIRCUIT DIAGRAM

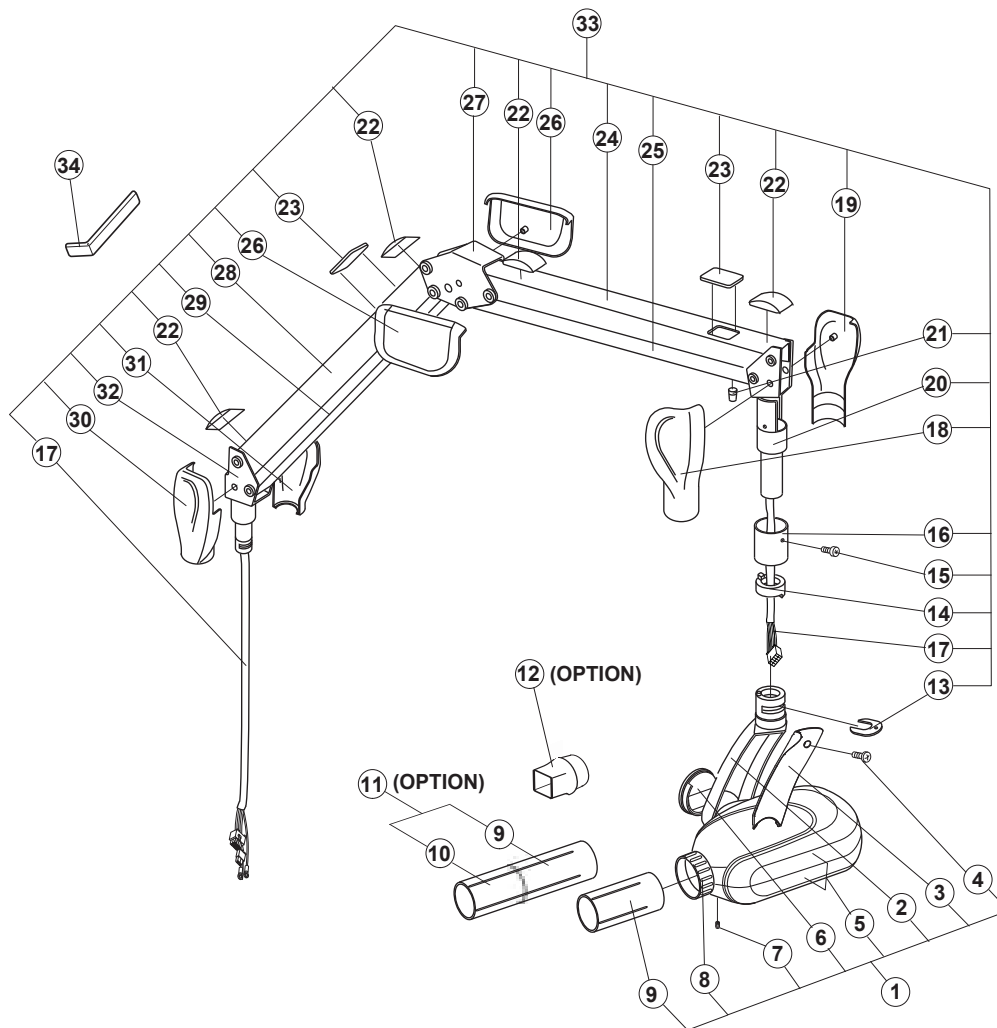


## APPENDIX 2 : MAINTENANCE CHECK LIST

Parameter	Acceptance limit	Frequency	Procedures when failed	OK/NG
1. Line voltage	Confirm the line voltage is within 120V±10%. Also confirm the voltage drop during exposure is within 5%.	Yearly	Connect to the power supply within 120V±10%. Check disconnection of wire or connection failure. Repair cable connection as needed.	
2. Tube current	Confirm the measured mA value indicated on the LCD screen is within the rated value ± 1 mA.	Yearly	Perform mA calibration. (Refer to page 27 of Installation manual.)	
3. Tube potential	Confirm the measured kV value indicated on the LCD screen is within the rated value ±10%.	Yearly	Check the tube potential compensation (CP) values are same as the values on the label in the head yoke.	
4. Timer	Confirm the error of the measured value by non-invasive exposure time meter is within ±5% or 20mS at 0.01 and 2.0 seconds exposure. *The non-invasive time meter should be calibrated to measure the radiation from dental x-ray.	Yearly	Exchange the power PC board to new one and check the result.	
5. Wall mounting plate	Confirm the wall plate is firmly fixed to the wall.	Yearly	If bolts are loose, find the reason why bolts became loose and take counter measure that prevents bolts from becoming loose.	
6. Arm mounting bracket	Make sure that the arm bracket is firmly attached to the wall plate.	Yearly	If bolts that fix the arm bracket to the wall plate are loose, find the reason why bolts became loose and take counter measure that prevents bolts from becoming loose.	
7. Dosimetry	Save the image that was taken under appropriate conditions as a reference image. Compare a newly taken image with a reference image to assure the image quality.	Weekly	If the image quality is found poor comparing to a reference image, check the condition of image receptor (film, sensor or imaging plate), image developer (developing fluid, dental film developer, PC or scanner). If they are OK, then set appropriate film / sensor speed by referring to page 23 of installation manual.	
8. Horizontal arm	Confirm that horizontal arm is firmly inserted to the arm bracket. Make sure the retaining bolt is firmly inserted to the arm bracket.	Daily (before use)	If the retaining bolt is loose, find the reason why bolt became loose and take counter measure that prevents the retaining bolt from becoming loose.	
9. Head	Confirm the head can be smoothly positioned.	Daily (before use)	Adjust the brake screws by referring to page 17 of installation manual.	
10. Balance arm	Confirm the balance arm moves smoothly without making noise.	Daily (before use)	Adjust the tension of the balance arm by referring to page 17 of installation manual. If the balance arm makes noise, apply grease.	

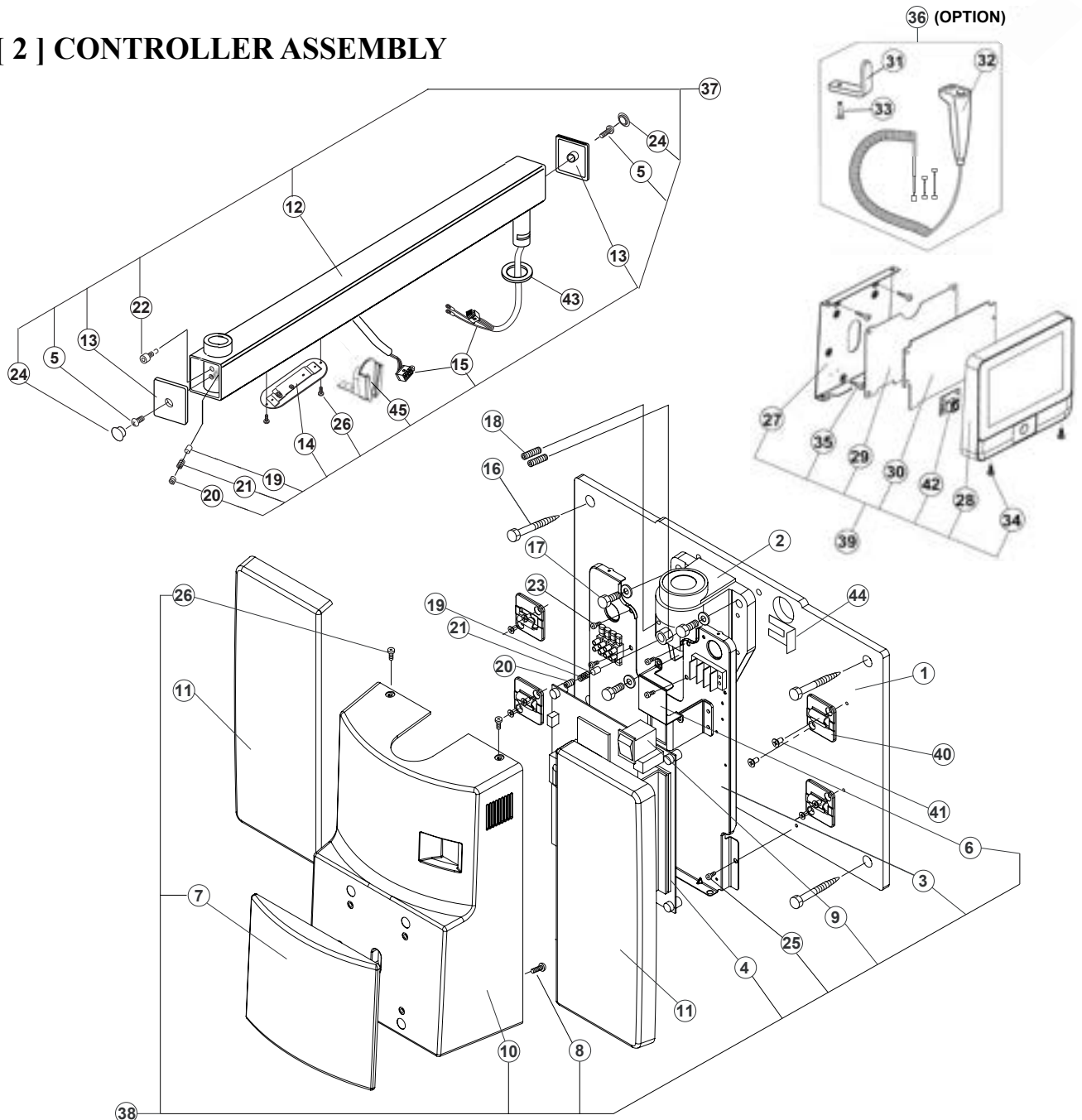
## APPENDIX 3 : PARTS IDENTIFICATION

### [ 1 ] ARM AND HEAD ASSEMBLY



ID.No.	Parts No.	Description	QTY
1	1P03TGA0	X-Ray Head Assembly	1
2	1A0FU4A0	Yoke	1
3	1A0FUGA0	Yoke Inside Cover	1
4	ZA111L#U	Yoke Inside Cover Screw (M4 x 15)	1
5	1P03JRA0	Head Housing Cover Set	1set
6	ECQR60A0	Yoke Side Cap	1
7	ZA220JPC	Yoke Side Cap Screw (ø 3 x 8)	1
8	ECPJ65A0	Lock Ring	1
9	1P04W8A0	Short Cone	1
10	1P04W6A0	Long Cone Collimator (Option)	(1)
11	1P04W7A0	Long Cone Assembly (Option)	(1)
12	1P05DBA0	Rectangular Collimator (Option)	(1)
13	ECQR62A0	Head Key	1
14	ECQR24A0	Stopper Ring	1
15	1E0182A0	Arm Collar Screw (M4 x 8)	1
16	ECQR31A0	Arm Collar	1
17	1P03JSA0	Wire Harness in Balance Arm	1
18	1A0FU7A0	Right Cover for Joint No.3	1
19	1A0FU8A0	Left Cover for Joint No.3	1
20	ECPE16E0	Joint No.3	1
21	ECQR33A0	Cushion Absorber	1
22	1A0FUCA0	Crevice Cover	4
23	1A0FUDA0	Spring Adjuster Cover	2
24	1A0FULA0	Arm Cover No.2	1
25	ECPE30B0	Balance Arm No.2	1
26	1A0FUBA0	Cover for Joint No.2	2
27	ECPJ58B0	Joint No.2	1
28	1A0FUKA0	Arm Cover No.1	1
29	ECPE31B0	Balance Arm No.1	1
30	1A0FUAA0	Left Cover for Joint No.1	1
31	1A0FU9A0	Right Cover for Joint No. 1	1
32	ECPE15B0	Joint No.1	1
33	1P0528A0	Balance Arm Assembly	1
34	ECLJ82A0	Balance Arm Wrench	1

## [ 2 ] CONTROLLER ASSEMBLY



ID.No.	Parts No.	Description	QTY
1	1A0FUJA0	Wall Plate	1
2	ECPE34B0	Arm Mounting Bracket	1
3	1A0389B0	Chassis	1
4	1A0ERXA0	Power PC Board	1
5	1E0178A0	End Cap Screw (M6 x 15)	2
6	1A0387A0	Restriction Plate	1
7	1A0FTZA0	Front Panel	1
8	1E054VA0	Screw for Front Panel (ø3 x 8)	1
9	1E01J8A0	Main Power Switch	1
10	1A0FTYA0	Front Cover	1
11	1A0FUEA0	Side Cover	1
12	1A0KGWB0	Horizontal Arm Frame (800mm)	1
13	ECLJ36A0	Arm End Cap	2
14	1A0KH5A0	Arm Bottom Cover	2
15	1P04E3A0	Wire Harness in Horizontal Arm (800mm)	1
	1P04E4A0	Wire Harness in Horizontal Arm (1000mm)	
	1P04E0A0	Wire Harness in Horizontal Arm (300mm)	
	1P04E1A0	Wire Harness in Horizontal Arm (500mm)	
	1P04E2A0	Wire Harness in Horizontal Arm (650mm)	
16	1E00HBA0	Lag Screw (ø9 x 75)	4
17	ZA80APWT	Machine Bolt (M8 x 20)	3
18	ECPR44B0	Retaining Bolt	2
19	ECLS06B0	Brake Plug	2
20	ZA7710NB	Brake Screw (M6 x 6)	2
21	ECLS11B0	Brake Spring	2
22	ECLS09B0	Stopper Screw	1
23	ZA887LRY	Screw for Chassis (M4 x 10)	4

ID.No.	Parts No.	Description	QTY
24	ECNR24A0	Hole Plug for End Cap	2
25	ZA887LNY	Screw for Chassis (M4 x 6)	2
26	1E05XSA0	Screw for Cover (M3 x 8)	2
27	1A0LYNC0	Chassis for Sub Controller	1
28	1A0M2CA0	Front Panel for Sub Controller	1
29	1A0MZEC0	Protector for Timer PC Board	1
30	1A0N9PA0	Timer PC Board	1
31	1A0WU8A0	Hook for Hand Exposure Switch (Option)	1
32	1P059CA0	Hand Exposure Switch Assembly (Option)	1
33	ZA112JRY	Countersunk Screw (M3 x 10) (Option)	1
34	1E01A8A0	Front Cover screw for Sub Controller (M3 x 8)	2
35	ZA121WY	Wood Screw (ø4.1 x 20)	4
36	1P05A3B0	Hand Exposure Switch with hook (Option)	1
37	1P04E8B0	Horizontal Arm Assembly (800mm)	1
	1P04E9B0	Horizontal Arm Assembly (1000mm)	
	1P04E5B0	Horizontal Arm Assembly (300mm)	
	1P04E6B0	Horizontal Arm Assembly (500mm)	
	1P04E7B0	Horizontal Arm Assembly (650mm)	
38	1P04SUA0	Main Controller Assembly	1
39	1P0525A0	Sub Controller Assembly	1
40	1A0FUFA0	Hook for Side Cover	1
41	ZA112LNU	Screw for Hook (M4 x 6)	1
42	1G06N8A0	Exposure Switch PC Board	1
43	EEMV52B0	Thrust Washer	1
44	1A0TCZA0	Shim	6
45	1S02BVA0	Sensor Holder Assembly	1

# APPENDIX 4 : CERTIFICATION

FDA form 2579 must be filled and submitted to the purchaser and the relevant authorities within 15 days of completion of the installation. The fillable PDF copy of form 2579 is available online at <https://www.fda.gov/media/144454/download>.

Also fill the warranty card and the Assembler's Installation Report and return to Belmont Equipment.

## REFER TO THE SAMPLE FORM:

FOR FDA USE ONLY	<b>DEPARTMENT OF HEALTH AND HUMAN SERVICES</b> PUBLIC HEALTH SERVICE FOOD AND DRUG ADMINISTRATION <b>REPORT OF ASSEMBLY                  OF A DIAGNOSTIC X-RAY SYSTEM</b>	From Approved: OMB No. 0910-0213 Expiration Date: December 31, 1992 See reverse for OMB statement.  XXXXXXXX	
<b>1. EQUIPMENT LOCATION</b>			
a. NAME OF HOSPITAL, DOCTOR OR OFFICE WHERE INSTALLED		a. COMPANY NAME	
b. STREET ADDRESS		b. STREET ADDRESS	
c. CITY	d. STATE	c. CITY	d. STATE
e. ZIP CORD	f. TELEPHONE NUMBER	e. ZIP CORD	f. TELEPHONE NUMBER
<b>2. ASSEMBLER INFORMATION</b>			
<b>3. GENERAL INFORMATION</b>			
a. THIS REPORT IS FOR ASSEMBLY OF CERTIFIED COMPONENTS WHICH ARE (Check appropriate box(es))			
<input checked="" type="checkbox"/> NEW ASSEMBLY - FULLY CERTIFIED SYSTEM <input type="checkbox"/> REASSEMBLY - FULLY CERTIFIED SYSTEM <input type="checkbox"/> REASSEMBLY - MIXED SYSTEM (Both certified and uncertified components)			
<input type="checkbox"/> REPLACEMENT COMPONENTS IN AN EXISTING SYSTEM <input type="checkbox"/> AN ADDITION TO AN EXISTING SYSTEM			
b. INTENDED USE(S) (Check applicable box(es))			
<input type="checkbox"/> GENERAL PURPOSE RADIOGRAPHY <input type="checkbox"/> GENERAL PURPOSE FLUOROSCOPY <input type="checkbox"/> TOMOGRAPHY (Other than CT) <input type="checkbox"/> ANGIOGRAPHY		<input type="checkbox"/> PODIATRY <input type="checkbox"/> UROLOGY <input type="checkbox"/> MAMMOGRAPHY <input type="checkbox"/> CHEST <input type="checkbox"/> CHIROPRACTIC	
<input type="checkbox"/> CT HEAD SCANNER <input type="checkbox"/> CT WHOLE BODY SCANNER <input type="checkbox"/> HEAD - NECK (Medical) <input checked="" type="checkbox"/> DENTAL - INTRAORAL <input type="checkbox"/> DENTAL - CEPHALOMETRIC		<input type="checkbox"/> DENTAL PANORAMIC <input type="checkbox"/> RADIATION THERAPY SIMULATOR <input type="checkbox"/> C - ARM FLUOROSCOPIC <input type="checkbox"/> DIGITAL <input type="checkbox"/> OTHER (Specify in comments)	
c. THE X-RAY SYSTEM IS (Check one)		d. THE MASTER CONTROL IS IN ROOM	
<input checked="" type="checkbox"/> STATIONARY <input type="checkbox"/> MOBILE		Location of Control Box e. DATE OF ASSEMBLY (mo.) (day) (yr.)	
<b>4. COMPONENT INFORMATION</b> (If additional space is needed for this section use another form, replacing the preprinted number with form Number and complete items 1,4, and 5 only)			
a. THE MASTER CONTROL IS		b. CONTROL MANUFACTURER	
<input checked="" type="checkbox"/> A NEW INSTALLATION <input type="checkbox"/> EXISTING (Certified) <input type="checkbox"/> EXISTING (Non-certified)		Takara Belmont, USA Inc.	
		c. CONTROL MODEL NUMBER	
		505-CM, 505-CS	
		b. CONTROL SERIAL NUMBER	
		✓	
		c. SYSTEM MODEL NAME (CT Systems Only)	
Complete the following information for the certified components listed below which you installed. For beam limited device, tables and CT gantries the manufacturer and Model number in the indicated spaces. For other certified components, enter in the appropriate block how many of each you installed in this system.			
f. SELECTED COMPONENTS			
BEAM LIMITED DEVICE	MANUFACTURER	MODEL NUMBER	DATE MANUFACTURED
	MANUFACTURER	MODEL NUMBER	DATE MANUFACTURED
TABLES	MANUFACTURER	MODEL NUMBER	DATE MANUFACTURED
	MANUFACTURER	MODEL NUMBER	DATE MANUFACTURED
CT GANTRY	MANUFACTURER	MODEL NUMBER	DATE MANUFACTURED
f. OTHER CERTIFIED COMPONENTS (Enter number of each installed in appropriate blocks)			
1 X-RAY CONTROL		<input type="checkbox"/> CRADLE	
<input type="checkbox"/> HIGH VOLTAGE GENERATOR		<input type="checkbox"/> FILM CHANGER	
<input type="checkbox"/> VERTICAL CASSETTE HOLDER		<input type="checkbox"/> IMAGE INTENSIFIER	
<input type="checkbox"/> TUBE HOUSING ASSEMBLY (Medical)		<input type="checkbox"/> SPOT FILM DEVICE	
1 DENTAL TUBE HEAD		<input type="checkbox"/> OTHER (Specify)	
<b>5. ASSEMBLER CERTIFICATION</b>			
I affirm that all certified components assembled or installed by me for which this report is being made, were adjusted and tested by me according to the instructions provided by the manufacturer(s), were of the type required by the diagnostic x-ray performance standard (21 CFR Part 1020), were not modified to adversely affect performance, and were installed in accordance with provisions of 21 CFR Part 1020. I also affirm that all instruction manuals and other information required by 21 CFR Part 1020 for this assembly have been furnished to the purchaser and within 15 days from the date of assembly, each copy of this report will be distributed as indicated at the bottom of each copy.			
a. PRINTED NAME	b. SIGNATURE	c. DATE	
✓	✓	✓	
d. COMMENTS			

FORM FDA 2579(7/92) PREVIOUS EDITION IS OBSOLETE



BELMONT EQUIPMENT, Division of Takara Belmont, USA, Inc.

101 Belmont Drive Somerset, New Jersey 08873 U.S.A. TEL.:(732) 469-5000 / (800) 223-1192  
 www.belmontequip.com Fax.:(732) 526-6322 / (800) 280-7504

Book No. 1A0N9QN0  
 Printed in Japan 2024\_08