

PHOT-XIS

Model 505

DENTAL X-RAY

OPERATOR'S INSTRUCTIONS

Wall Mount Type.....WK

 **Belmont[®]**

INDEX

[1] INTRODUCTION

1. GENERAL

This manual provides information for the operation and maintenance procedures and technical specifications for PHOT-X IIs Model 505 dental x-ray. The instructions contained in this book should be thoroughly read and understood before operation.

PHOT-X IIs Model 505 has no user serviceable items. Repair should be performed by qualified dealer service personnel.

2. INTENDED USE OF THE PRODUCT

PHOT-X IIs Model 505 is a extraoral source dental radiographic x-ray unit. This unit works as a diagnostic purpose x-ray source for human teeth with resultant image recorded on intraoral dental x-ray film or image receptor.

3. PARTS IDENTIFICATION OF X-RAY SYSTEM "PHOT-X IIs Model 505"

- a. Tube housing assembly : 505-H
- b. X-ray controls : 505-CM (main controller), 505-CS (sub controller)
- c. Cones : 505-R (regular), 505-L (long)
- d. Collimator : 505-REC (rectangular)
- e. Balance arm : 505-A

4. COMPLIANCE WITH STANDARD

BELMONT PHOT-X IIs MODEL 505 x-ray unit complies with the following standard.

- a. Electrical and Mechanical Safety
IEC60601-1:2005, IEC60601-1-3:2008, IEC60601-2-65:2012
AMMI ES60601-1:2005
- b. Radiation Safety
21 CFR 1020.30

5. CLASSIFICATION























5-1. According to Section 513 of Federal Food, Drug and Cosmetic Act and 21 CFR Part 806, BELMONT PHOT-X IIs Model 505 is classified as CLASS II Medical Device.

5-2. According to IEC60601-1, BELMONT PHOT-X IIs Model 505 is classified as follows.

- a. Protection against electric shock : Class I Equipment
- b. Protection against ingress of water : Ordinary
- c. Mode of operation : Non continuous (Duty Cycle = 1 : 30)
- d. Equipment not suitable for use in the presence of a flammable anesthetic mixture with air or with oxygen or nitrous oxide.

6. SYMBOL

In this book, on the labels or on the control panel of PHOT- X IIs Model 505, following symbols are used. Confirm the meaning of each symbol.

	Consult written Instructions in Manuals		Digital Imaging		ON (POWER)		OFF (POWER)
	Protection Grounding		Exposure Switch		X-ray Emission		Ready
	Upper Incisor		Upper Cuspid & Pre Molar		Upper Molar		Occlusal
	Lower Incisor		Lower Cuspid & Pre Molar		Lower Molar & Bite Wing		Bite Wing
	Regular Cone		Patient Child		Patient Adult		Patient Large Adult
	Long Cone		Non-ionizing Radiation		Date of Manufacture		

7. SAFETY

This X-ray Unit may be dangerous to patient and operator, if safe exposure factors, operating instructions and maintenance schedules are not observed.

Only qualified and authorized personnel may operate this equipment observing all laws and regulations concerning protection against x-ray radiation.

The operator must :

- have means for audio and visual communication with the patient.
- have full view of kV, mA, timer selections and exposure warning light.
- be at least 2 m away from the x-ray head and patient and out of the path of the x-ray beam or be positioned behind a protective device.
- fully use all radiation protection devices, accessories and procedures available to protect the patient and operator from x-ray radiation.

[2] LAYOUT OF CONTROLS

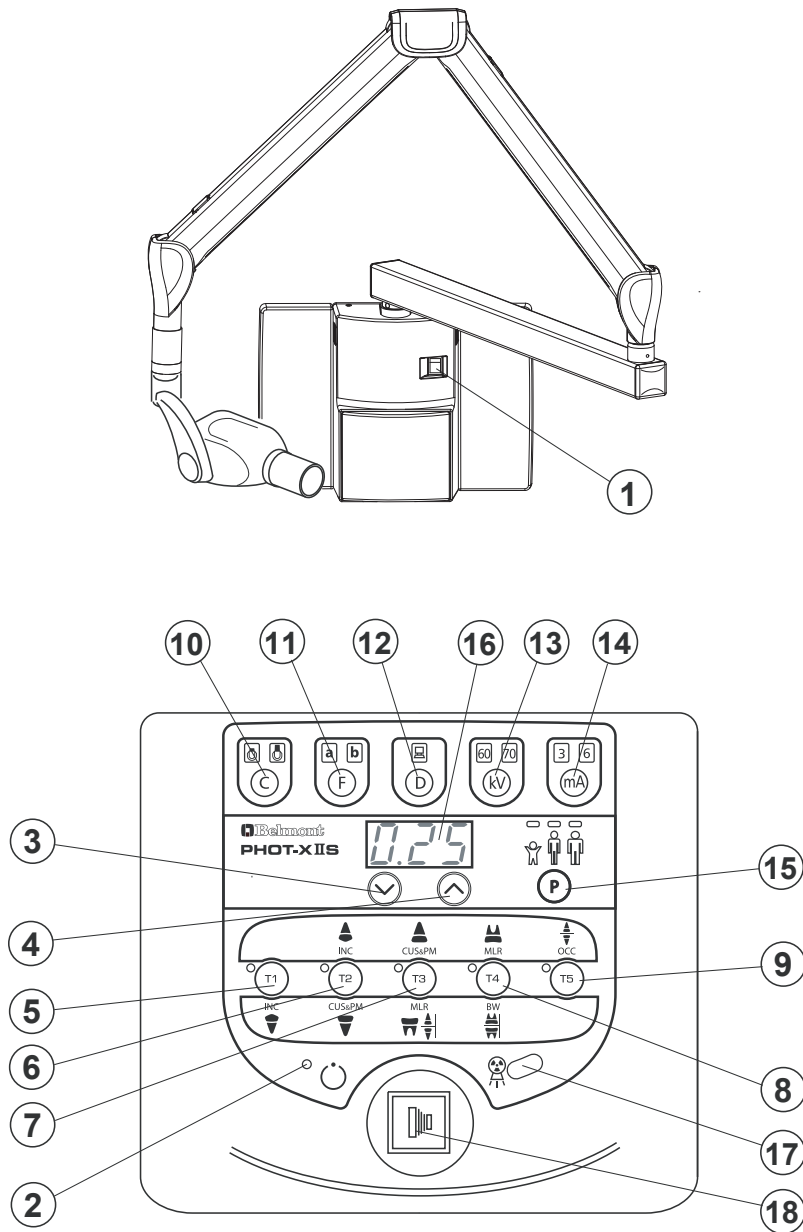

- | | |
|--|---------------------------------|
| ① Main Power Switch | ⑩ Cone Type Selection Switch |
| ② Ready Light | ⑪ Film Speed Selection Switch |
| ③ ExposureTime Adjusting Switch (Down) | ⑫ Digital Imaging Switch |
| ④ ExposureTime Adjusting Switch (Up) | ⑬ kV Selection Switch |
| ⑤ Tooth Selection Switch (T1) | ⑭ mA Selection Switch |
| ⑥ Tooth Selection Switch (T2) | ⑮ Patient Size Selection Switch |
| ⑦ Tooth Selection Switch (T3) | ⑯ ExposureTime Display Window |
| ⑧ Tooth Selection Switch (T4) | ⑰ ExposureWarning Light |
| ⑨ Tooth Selection Switch (T5) | ⑱ Exposure Switch |

[2] FUNCTION OF CONTROLS

① Main Power Switch

Pushing the upper side of this switch to the ON position energizes the x-ray unit. (Ready light and pre-select lights for cone type, film or digital, kV, mA, and patient size illuminate.) It is recommended to keep this switch OFF when the unit is not in use, in order to prevent an accidental exposure.

IMPORTANT : To prevent the risk of an accidental exposure, push the lower side of this switch to the OFF position, when the unit is not in use.

② Ready Light

This light illuminates when the line voltage is within operable range (108 ~ 132Vac). When this light is not on, exposure can not be made.

③④ Exposure Time Adjusting Switches

By momentarily pushing the \wedge (or \vee) switch, the exposure time displayed increases (or decreases) by one increment. By keeping the switch depressed more 2 sec., the exposure time displayed increases (or decreases) continuously until the switch is released.

Model 505 has the following 37 exposure time settings :

0.00, 0.01, 0.02, 0.03, 0.04, 0.05, 0.06, 0.07, 0.08, 0.09, 0.10, 0.11, 0.13, 0.14, 0.16, 0.18, 0.20, 0.22, 0.25, 0.28, 0.32, 0.36, 0.40, 0.45, 0.50, 0.56, 0.63, 0.71, 0.80, 0.90, 1.00, 1.12, 1.25, 1.40, 1.60, 1.80, 2.00(sec.)

⑤ ~ ⑨ Tooth Selection Switches (T1 ~ T5)

Pushing one of these switches sets the exposure time automatically for the following ⑩ ~ ⑮ .

⑤ T1 : Incisor of Mandible

⑥ T2 : Incisor of Maxilla, Cuspid & Premolar of Mandible

⑦ T3 : Cuspid & Premolar of Maxilla, Molars of Mandible, Bitewing

⑧ T4 : Molar of Maxilla, Bitewing Molars

⑨ T5 : Occlusal

If the T1 switch⑤ is depressed more than 3 sec. unit goes into " Lock Mode". In lock mode, the only functional switch is the power switch. To exit from the lock mode, depress the T1 switch more than 3 sec. again.

⑩ Cone Type Selection Switch

By depressing this switch for less than 2 sec., selected cone type can be confirmed. If round cone is selected, "rnd" is displayed. If the cone with rectangular collimator is selected, "rEC" is displayed. Depressing this switch more than 2 sec. changes the cone type by the following order.

Short cone (Round) --> Short cone with rectangular collimator --> Long cone (Round) -->

Long cone with rectangular collimator --> Short cone (Round) --> continued

⑪ Film Speed Selection Switch

a. PHOT-X IIs has 16 film speed settings. (F.00 ~ F.15)





Two speed settings are pre-set at the factory (a & b) and can be selected with switch⑪.

a = Film speed No. F.09 (equivalent to ISO speed group " D", or Kodak Ultra-Speed film)

b = Film speed No. F.05 (equivalent to ISO speed group " F/E", or Kodak InSight film)

Including these two speeds, PHOT-X IIs Model 505 x-ray can provide 16 different film speeds (F.00 ~ F.15) and any two of them can be programmed for easy selection. If doctor uses a different film speed, or prefers darker (or lighter) radiographs, the new speed can be programmed as follows. Higher speed settings make films darker. If film speed is increased by 1, exposure time becomes 25 % longer.



1. Keep the kV selection switch and mA selection switch depressed simultaneously for more than 3 seconds. Release the switches if the ready light starts to flash.

2. Push F switch momentarily until the "a" light above the F switch illuminates. The exposure time display window shows the present film speed for "a" setting. (The factory default setting, F.09 should be displayed.) By depressing  or  switch, increase or decrease film speed number until desired number for "a" setting is displayed.
 3. To change the "b" setting from the factory default, F.05, push F switch momentarily until the "b" light illuminates. By depressing  or  switch, increase or decrease film speed until the desired number for "b" setting is displayed.
 4. Press T1 switch to store these settings, then turn the main power switch off.
- b. Pushing **Film Speed Selection Switch** ⑪ momentarily displays the selected film speed setting in the **Exposure Time Display Window** ⑩
Depressing this switch for more than 2 sec. changes the film type being selected.
- c. If the **Digital Imaging Switch** ⑫ is depressed, both of the film speed indicating lights (a & b) are turned off.

⑫ Digital Imaging Switch

If a digital imaging system is used, shorter exposure time is often required. PHOT-X IIs has 16 speeds for digital imaging (d.00 ~ d.15). Pushing this switch momentarily displays the speed being selected in the **Exposure Time Display Window** ⑩. With the factory speed setting d.10, the exposure time becomes half of F.10 setting.

As the sensitivity is different according to each manufacturer of digital imaging sensors, this setting should be adjusted. To get a darker image, increase the speed setting and to get a lighter image, decrease the speed setting. If the speed setting is increased by 1, exposure time becomes 12 % longer.

1. Keep kV selection switch and mA selection switch depressed simultaneously for more than 3 seconds.
2. Push D switch momentarily until the light above the D switch illuminates and the exposure time display window shows the present speed setting. (The factory default setting d.10 should be displayed.)
3. By depressing  or  switch, increase or decrease speed until the desired number is displayed.
4. Press **T1 switch** to store these settings, then turn the main power switch off.

⑬ kV Selection Switch

Momentarily depressing this switch will change the tube potential to 60 or 70 kV. If either the Film Speed Switch ⑪ or Digital Imaging Switch ⑫ is depressed, 60kV is automatically selected.

⑭ mA Selection Switch

Momentarily depressing this switch will change the tube current setting (3 or 6 mA). If the Digital Imaging Switch ⑫ is depressed, 3 mA is automatically selected and if the Film Speed Switch ⑪ is depressed, 6 mA is automatically selected.

Speed Setting	kV	mA	Child					Adult					Large Adult				
			T1	T2	T3	T4	T5	T1	T2	T3	T4	T5	T1	T2	T3	T4	T5
F. 09	60	3	0.20	0.25	0.28	0.32	0.50	0.32	0.40	0.50	0.56	0.80	0.40	0.50	0.63	0.71	1.00
		6	0.10	0.11	0.14	0.16	0.25	0.16	0.20	0.25	0.28	0.40	0.20	0.25	0.28	0.36	0.50
	70	3	0.14	0.16	0.20	0.22	0.36	0.25	0.28	0.36	0.40	0.56	0.28	0.36	0.45	0.50	0.71
		6	0.07	0.08	0.10	0.11	0.18	0.11	0.14	0.18	0.20	0.28	0.14	0.18	0.22	0.25	0.36
F. 05	60	3	0.08	0.10	0.11	0.14	0.20	0.14	0.16	0.20	0.22	0.32	0.18	0.20	0.25	0.28	0.40
		6	0.04	0.05	0.06	0.07	0.10	0.07	0.08	0.10	0.11	0.16	0.09	0.10	0.13	0.14	0.20
	70	3	0.06	0.07	0.08	0.10	0.14	0.10	0.11	0.14	0.16	0.25	0.13	0.14	0.18	0.20	0.28
		6	0.03	0.04	0.04	0.05	0.07	0.05	0.06	0.07	0.08	0.11	0.06	0.07	0.09	0.10	0.14
d.10	60	3	0.13	0.14	0.18	0.20	0.28	0.20	0.25	0.28	0.36	0.50	0.25	0.32	0.36	0.40	0.63
		6	0.06	0.07	0.09	0.10	0.14	0.10	0.13	0.14	0.16	0.25	0.13	0.16	0.18	0.22	0.32
	70	3	0.09	0.11	0.13	0.14	0.22	0.14	0.18	0.22	0.25	0.36	0.18	0.22	0.25	0.32	0.45
		6	0.04	0.05	0.06	0.07	0.11	0.07	0.09	0.11	0.13	0.18	0.09	0.11	0.13	0.16	0.22

Speed Setting	kV	mA	Child					Adult					Large Adult				
			T1	T2	T3	T4	T5	T1	T2	T3	T4	T5	T1	T2	T3	T4	T5
F. 09	60	3	0.40	0.50	0.63	0.71	1.00	0.71	0.80	1.00	1.12	1.60	0.90	1.00	1.25	1.40	2.00
		6	0.20	0.25	0.28	0.36	0.50	0.36	0.40	0.50	0.56	0.80	0.45	0.50	0.63	0.71	1.00
	70	3	0.28	0.36	0.45	0.50	0.71	0.50	0.56	0.71	0.80	1.25	0.63	0.71	0.90	1.00	1.40
		6	0.14	0.18	0.22	0.25	0.36	0.25	0.28	0.36	0.40	0.56	0.32	0.36	0.45	0.50	0.71
F. 05	60	3	0.18	0.20	0.25	0.28	0.40	0.28	0.36	0.40	0.45	0.71	0.36	0.45	0.50	0.56	0.90
		6	0.09	0.10	0.13	0.14	0.20	0.14	0.18	0.20	0.25	0.36	0.18	0.22	0.25	0.28	0.45
	70	3	0.13	0.14	0.18	0.20	0.28	0.20	0.25	0.28	0.32	0.50	0.25	0.32	0.36	0.40	0.63
		6	0.06	0.07	0.09	0.10	0.14	0.10	0.13	0.14	0.16	0.25	0.13	0.16	0.18	0.22	0.32
d.10	60	3	0.25	0.32	0.36	0.45	0.63	0.45	0.50	0.63	0.71	1.00	0.56	0.63	0.80	0.90	1.25
		6	0.13	0.16	0.18	0.22	0.32	0.22	0.25	0.32	0.36	0.50	0.28	0.32	0.40	0.45	0.63
	70	3	0.18	0.22	0.28	0.32	0.45	0.32	0.36	0.45	0.50	0.71	0.40	0.45	0.56	0.63	0.90
		6	0.09	0.11	0.13	0.16	0.22	0.16	0.18	0.22	0.25	0.36	0.20	0.22	0.28	0.32	0.45

15 Patient Size Selection Switch

This switch alters the selection of patient type/size to be radiographed (child adult large adult child) and sets the exposure time automatically. If the weight of child is less than 20kg, press

switch once after setting to child. If the weight of child is over 50kg and less than 70kg, press switch twice after setting to child. If the weight of child is over 70kg, set to adult.

NOTE: Setting or adjusting the exposure time manually (with or switch) supersedes

[4] OPERATING PROCEDURES

1. Turn ON the Main Power Switch ①.
2. Confirm that Ready Light ② is illuminated.

NOTE : The ready light will not illuminate unless the incoming line voltage is correct and within the x-ray's operable range (108 ~ 132V AC).

3. Select the appropriate tooth type (⑤ ~ ⑨), and confirm the pre-selected conditions (cone type, film or digital, kV, mA and patient size) are suitable for exposure.

NOTE : To manually set the exposure time, depress either of the Manual Exposure Time Adjusting Switches (⤴ or ⤵) until the desired exposure time appears in the Exposure Time Display Window ⑩. While the unit is in manual mode, other selection switches (⑤ ~ ⑮) do not affect exposure time. (All of the tooth selection lights are off.) To return to the automatic exposure time selection mode, depress any one of Tooth Selection Switches (⑤ ~ ⑨).

4. Depress the Exposure Switch ⑱. When the Exposure Switch is depressed, the Exp. Warning Light ⑰ illuminates and the audible warning sounds. Do not release the Exposure Switch until the Exposure Warning Light and audible warning automatically shut off. Failure to keep the switch depressed will result in exposure being terminated prematurely.

5. To continue to radiograph other teeth, just select appropriate Tooth Selection Switches (⑤ ~ ⑨).

IMPORTANT : To protect x-ray tubehead from heat accumulation, wait for a time interval that is equal to 30 times the selected exposure time before making additional exposures. (Example : a 15 sec. wait is necessary between exposures that are 0.5 sec. in duration.)

6. Turn OFF the Main Power Switch ① in order to prevent accidental exposures when the unit is not in use.

NOTE : If the unit left over 8 min. without being operated and the Main Power Switch ① is kept on, figure "1" runs through the Exposure Time Display Window ⑩. This does not mean that malfunction of the unit has occurred ; this is an energy saving feature. The unit returns to ready condition by pressing any one of the switches, except the Exposure Switch ⑱.

[5] ESTIMATED AIR KERMA

Estimated air kerma (radiation output) at distal of cone can be displayed in the exposure time window by depressing the patient switch for more than 1 second. Unit for this value is mGy and this value is calculated by kV, mA, Exposure time and cone type selected at that time.

Patient type display lamps and displayed value in the window are flashing in this mode and if either of the manual exposure time adjusting switches is depressed during this mode, accumulated air kerma will be displayed. Accumulated value will be reset when the power switch is turned off or leave the x-ray unit more than 8 minutes without depressing any switch. To return to normal mode, press the patient switch for more than 1 second again or leave the controller untouched for more than 10 seconds.

[6] OPTIONAL HAND EXPOSURE SWITCH

An optional hand exposure switch can be connected to the sub controller. Since this exposure switch has a coiled cord, operators can stand in the most suitable position for operation. As controller has separate connector for this exposure switch, both exposure switch ⑱ on the front panel of sub controller and this hand exposure switch can be used.

If local code prohibits use of both, ask installer to disconnect the connector of either switch.

[7] DIGITAL IMAGING SYSTEM

No x-ray image receptor is integrated in PHOT-X IIs Model 505 x-ray system. If image receptor used with PHOT-X IIs Model 505, the type and performance of the receptor should as follows.

- 1.Type of receptor : CCD(charge-coupled device), CMOS(complimentary metal oxide semiconductor) or PSP (photostimulable phosphor plate) receptor for dental intraoral use.
- 2.Adequate amount of x-radiation for the receptor should be between 0.02mGy and 23.6mGy.
- 3.Use the receptor holder and receptor cover recommended by the manufacturer of image receptor.
- 4.Receptor holder should keep the image receptor firmly at the position and works as the x-ray beam alignment device.

WARNING

The use of ACCESSORY equipment not complying with the equivalent safety requirements of PHOT-X IIs Model 505 may lead to a reduced level of safety of the resulting system.

Consideration relating to the choice shall include :

- use of the accessory in the **PATIENT VICINITY**
- evidence that the safety certification of the **ACCESSORY** has been performed in accordance to the appropriate **IEC60601-1 and/or IEC60601-1 harmonized national standard.**

[8] DISINFECTION AND CLEANING

1. DISINFECTION

- (a) X-ray operator is required to wear disposable gloves when taking radiographs and handling contaminated film packet or digital detector cover. Gloves should be changed for each patient to avoid cross contamination. X-ray head, main controller and sub controller should be covered by single use barriers.
- (b) If you use film holders or digital detector holders that go into patient's mouth, properly sterilize them. Follow the sterilization procedures indicate by each manufacturer.

2. CLEANING

In order to ensure proper hygiene and cleaning of the equipment, the following procedure must be followed.

CAUTION

Before cleaning the unit, turn off the main power switch and breaker on the branch line. This is required because some internal parts remain connected to main voltage even when the main power switch has been turned off.

Never use the metal corrosive disinfectant, such as povidone iodine or sodium hypochlorite.

Do not pour or spray solvent or liquid directly on the x-ray unit.

Be careful not to allow solvents to run or drip into the x-ray unit.

Limitations on reprocessing : Repeated processing has minimal effect on these instruments.

End of life normally determined by wear and damage due to use.

Point of use : Remove excess soil with disposable cloth / paper wipe.

Preparation for cleaning : Turn off the main power switch and breaker on the branch line.

Disassembly is not required.

Cleaning : Wipe the outside surface with a paper towel dampened with a disinfectant solution or household, non abrasive cleaner.

Disinfection : To ensure proper cleaning of the parts in contact with skin, periodic disinfection with a non corrosive surface infectant is recommended.

Recommended disinfectant : FD333 (Durr Dental)

Drying : Allow surface to air dry before turning breaker and main switch back on.

[9] ERROR CODES

If an abnormal condition exists in the unit, or a malfunction occurs, an error code is displayed in the Exposure Time Display Window. Please refer to the Table below.

Error Code	Condition	Step to be Taken	Possible Solution
E.00	Exposure switch was released before exposure termination.	All the tooth selection lights blink. Depress one of the tooth switches.	Release the exposure switch after the exposure lamp turns off.
E.01	Exposure switch was depressed within 10 sec. of previous exposure.	A 10 sec. delay is built in between each exposure. Release the exposure switch.	There should be a "wait" interval of 30 times the exposure time between successive exposure.
	Exposure time was set and exposure switch was depressed within 3 sec. of the power switch being turned on.		Wait a minimum 3 sec. after the main power switch is turned on before pressing the exposure switch.
E.02	Line voltage was less than 90% of rated voltage.		Confirm that ready lamp is on before exposure. Ask service personnel to check the line voltage.
E.03	Line voltage was more than 110% of rated voltage.		
E.05	Tube current at last portion of exposure was less than 2 mA at 3 mA setting or less than 4.5 mA at 6 mA setting	Turn off the main power switch and wait for approximately 2 min. Turn on the main power switch again.	If same error code is displayed, call service personnel.
E.06	Tube current at last portion of exposure was more than 4 mA at 3 mA setting or more than 7.5 mA at 6 mA setting		
E.07	During the exposure, tube current becomes less than 1.5 mA at 3mA setting or less than 3 mA at 6 mA setting.		
E.08	During the exposure, tube current becomes more than 4.5 mA at 3mA setting or more than 9 mA at 6 mA setting.		
E.09	Setting for pre-heating time is out of range.		
E.10	Exposure switch or exposure circuit had been ON, when main power switch is turned on.		
E.11	Tube current is detected during pre-heating period.		
E.12	Tube current is detected when main power switch is turned on.		
E.14	Tube potential at last portion of exposure was less than 50 kV at 60 kV setting or less than 60 kV at 70 kV setting.		

Error Code	Condition	Step to be Taken	Possible Solution
E.15	Tube Potential at last portion of exposure was more than 70 kV at 60 kV setting.	Turn off the main power switch and wait for approximately 2 min. Turn on the main power switch again.	If same error code is displayed, call service personnel.
E.16	During the exposure, tube potential becomes less than 40 kV at 60 kV setting or less than 50 kV at 70 kV setting.		
E.17	During the exposure, tube potential becomes more than 80 kV.		
E.18	Excess current was detected in primary circuit of filament transformer.		
E.19	Excess current was detected in primary circuit of high voltage transformer.		
E.20	Exposure switch was depressed when tube head temperature was over 60°C.	Release the exposure switch,	
E.22	Failure of electrical communication between the power PCB and timer PCB.	Turn off the main power switch and turn on again.	
E.23	Some switch had been on, when the main power switch is turned on. (Except the exposure switch.)		

[10] MAINTENANCE

PHOT-X IIs Model 505 x-ray unit requires post installation confirmation and periodic maintenance checks to be performed by dealer service personnel. These procedures ensure that the x-ray unit is functioning within the manufacture's specifications and remains in compliance with the Standard.

It is responsibility of the owner of the unit to see that these maintenance checks are correctly performed. The specific instructions to perform these checks are located within the PHOT-X IIs Model 505 Installation instructions.

- a. Maintenance personnel : Qualified dealer service personnel who has the experience with Belmont's x-ray or has been trained by Belmont. But item 7 - 10 of the maintenance check list on page 11 should be verified routinely by treatment room personnel.
- b. Specification of the parameters to be monitored and monitoring frequency : Ref to the maintenance check list on page 11.
- c. Acceptance limit : Refer to the Maintenance check list on page 11.
- d. Required action when failed : Refer to the Maintenance check list on page 11.
- e. Tools to maintain quality control logs : Use the check list on page 11.
- f. Training material : Operator's instructions, Installation instructions and Service Manual

[11] DISPOSAL

1. Disposal of x-ray unit or components

The tube head of this x-ray unit contains the lead for x-ray shield and insulation oil, which is refined mineral oil and does not contain the carcinogenic substances such as PCBs.

When disposing the x-ray unit or components, appropriately dispose complying with all current applicable regulations and local codes.

2. Disposal of used film and CCD cover

Dispose the used film covers and CCD sensor covers appropriately, according to procedures indicated by each manufacturer and all current applicable regulations and local codes.

MAINTENANCE CHECK LIST

Parameter	Acceptance limit	Frequency	Procedures when failed	OK/NG
1. Line voltage	Confirm the line voltage is within 120V±10%. Also confirm the voltage drop during exposure is within 5%.	Yearly	Connect to the power supply within 120V±10%. Check disconnection of wire or connection failure. Repair cable connection as needed.	
2. Tube current	Confirm the measured mA value indicated on the LED window is within the rated value ± 1 mA.	Yearly	Perform MA adjustment. (Refer to page 24 of Installation instructions.)	
3. Tube potential	Confirm the measured kV value indicated on the LED window is within the rated value ±10%.	Yearly	Check the tube potential compensation (CP) values are same as the values on the label in the head yoke.	
4. Timer	Confirm the error of the measured value by noninvasive exposure time meter is within ±5% or 20mS at 0.01 and 2.0 seconds exposure. *The non invasive time meter should be calibrated to measure the radiation from dental x-ray.	Yearly	Exchange the power PC board to new one and check the result.	
5. Wall mounting plate	Confirm the wall plate is firmly fixed to the wall.	Yearly	If bolts are loose, find the reason why bolts became loose, take counter measure that prevents bolts become loose.	
6. Arm mounting bracket	Make sure that the arm bracket is firmly attached to the wall plate.	Yearly	If bolts that fix the arm bracket to the wall plate are loose, find the reason why bolts became loose, take counter measure that prevent bolts become loose.	
7. Dosimetry	Save the image that was taken under appropriate conditions as a reference image. Compare a newly taken image with a reference image to assure the image quality.	Weekly	If the image quality is found poor comparing to a reference image, check the condition of image receptor (film, sensor or imaging plate), image developer (developing fluid, dental film developer, PC or scanner). If they are OK, then set appropriate film / sensor speed by referring to page 26 of Installation instructions.	
8. Horizontal arm	Confirm that horizontal arm is firmly inserted to the arm bracket. Make sure the retaining bolt is firmly inserted to the arm bracket.	Daily (before use)	If the retaining bolt is loose, find the reason why bolt became loose, take counter measure that prevent the retaining bolt become loose.	
9. Head	Confirm the head can be smoothly positioned.	Daily (before use)	Adjust the brake screws by referring to page 16 of Installation instructions.	
10. Balance arm	Confirm the balance arm moves smoothly without making noise.	Daily (before use)	Adjust the tension of the balance arm by referring to page 16 of installation instructions. If the balance arm makes noise, apply grease.	

[12] TECHNICAL DATA

1. X-ray tube ----- Toshiba D-046 (Stationary Anode)
 - a. Nominal focal spot value ----- 0.4 (IEC60366)
 - b. Target Material----- Tungsten
 - c. Target angle ----- 12.5 deg
 - d. Maximum anode heat content ----- 4.3 kJ (6.1 kHU)
2. Maximum x-ray tube assembly heat content ----- 293kJ (413 kHU)
3. Rated peak tube potential ----- 60 kV / 70 kV selectable
4. Rated tube current ----- 3 mA / 6 mA selectable
5. Maximum rated peak tube potential ----- 70 kV
6. Rated line voltage ----- 120 VAC, 60 Hz, Single phase, 1.2 kVA
7. Line voltage range ----- 108 VAC ~ 132 VAC
8. Range of line voltage regulation----- 0 ~ 5 % (Apparent resistance 0.52 ohm)
9. Rated line current ----- 10 A at 70 kV, 6 mA
10. Maximum line current ----- 11 A at 70 kV, 6 mA
11. Exposure time ----- 0.01 ~ 2.0 sec.
12. Inherent filtration ----- 1.7 mm Al Equivalent
13. Added filtration ----- 0.3 mm Al
14. Minimum filtration permanently in useful beam ----- 2.0 mm Al Equivalent at 70 kV
15. Nominal radiation output

	60 kV	70 kV		
	3 mA	6 mA	3 mA	6 mA
a. Distal end of regular cone -----	4.6	9.1	5.9	11.8 mGy/sec. ± 40%
b. Distal end of long cone -----	2.0	4.1	2.6	5.2 mGy/sec. ± 40%

(Data obtained by direct measurement in the useful beam)
16. Nominal electrical output of H.V. generator ----- 0.42 kW at 70 kV, 6 mA
17. Cone

	Source to skin distance	Field size
a. Regular cone -----	8 inches (203 mm)	58 mm dia., circular
b. Long cone (option) -----	12 inches (305 mm)	58 mm dia., circular
c. Rectangular collimator (option) -----	SSD of cone + 40mm	32 x 40 mm, rectangular
18. Maximum symmetrical radiation field ----- 60 mm dia. at distal end of cone
19. Leaking technique factor ----- 70 kV / 0.19 mA (697mAs at 1 hour)
(0.19 mA is maximum rated continuous current for 6mA with a duty cycle 1:30)
20. Duty cycle ----- 1 : 30 (0.5 sec. exposure with 15 sec. interval)
21. Maximum deviation of tube potential, tube current and exposure time
 - a. Below 0.1 sec. setting ----- ±10 kV, ±2 mA, ±5 msec.
 - b. 0.1 sec. setting & up ----- ±5 kV, ±1 mA, ±10 msec.
22. Measurement base of technique factors
 - a. peak tube potential ----- Average of peak tube potentials during one exposure
 - b. tube current----- Average of tube current during one exposure
 - c. exposure time ----- Time period during x-ray is emitted
23. Half value layer ----- 1.5 mm Al over
24. Source to the base of cone distance ----- 94 mm
25. Environmental condition for storage ----- -20 ~ 70 °C, 10 ~ 100 %, 500 ~ 1060 hPa
26. Environmental condition for operation ----- 10 ~ 40 °C, 30 ~ 70 %, 700 ~ 1060 hPa
27. Dose area product ----- Estimated air kerma displayed [mGy]
x 26.4 [cm²] (for regular and long cone)
Estimated air kerma displayed [mGy]
x 12.8 [cm²] (for rectangular collimator)

[13] ELECTROMAGNETIC COMPATIBILITY (EMC)

Medical electrical equipment needs special precautions regarding EMC and needs to be installed and put into service according to the EMC information provided in this manual.

Portable and mobile RF communications equipment can affect medical electrical equipment. The equipment or system should not be used adjacent to or stacked with other equipment. If adjacent or stacked use is necessary, the equipment or system should be observed to verify normal operation in the configuration in which it will be used.

Guidance and manufacture's declaration – electromagnetic emissions		
The PHOT-X IIs 505 x-ray is intended for use in the electromagnetic environment specified below. The customer or the user of the PHOT-X IIs 505 x-ray should assure that it is used in such an environment.		
Emissions test	Compliance	Electromagnetic environment - guidance
RF emissions CISPR 11	Group 1	The PHOT-X IIs 505 x-ray uses RF energy only for its internal function. Therefore, its RF emissions are very low and are not likely to cause any interference in nearby electronic equipment.
RF emissions CISPR 11	Class A	The PHOT-X IIs 505 x-ray is suitable for use in all establishments other than domestic and those directly connected to the public low-voltage power supply network that supplies buildings used for domestic purposes.
Harmonic emissions IEC 61000-3-2	Class A	
Voltage fluctuations/ Flicker emissions IEC 61000-3-3	Complies	

Guidance and manufacture's declaration – electromagnetic immunity			
The PHOT-X IIs 505 x-ray is intended for use in the electromagnetic environment specified below. The customer or the user of the PHOT-X IIs 505 x-ray should assure that it is used in such an environment.			
Immunity test	IEC 60601 test level	Compliance level	Electromagnetic environment - guidance
Electrostatic discharge (ESD) IEC 61000-4-2	±6 kV contact ±8 kV air	±6 kV contact ±8 kV air	Floors should be wood, concrete or ceramic tile. If floors are covered with synthetic material, the relative humidity should be at least 30%.
Electrical fast transient/burst IEC 61000-4-4	±2 kV for power supply lines ±1 kV for input/output lines	±2 kV for power supply lines ±1 kV for input/output lines	Mains power quality should be that of a typical commercial or hospital environment.
Surge IEC 61000-4-5	±1 kV differential mode ±2 kV common mode	±1 kV differential mode ±2 kV common mode	Mains power quality should be that of a typical commercial or hospital environment.
Voltage dips, short interruptions and voltage variations on power supply input lines IEC 61000-4-11	<5% U_T (>95% dip in U_T) for 0.5 cycle 40% U_T (60% dip in U_T) for 5 cycle 70% U_T (30% dip in U_T) for 25cycle <5% U_T (>95% dip in U_T) for 5 s	<5% U_T (>95% dip in U_T) for 0.5 cycle 40% U_T (60% dip in U_T) for 5 cycle 70% U_T (30% dip in U_T) for 25cycle <5% U_T (>95% dip in U_T) for 5 s	Mains power quality should be that of a typical commercial or hospital environment. If the user of the PHOT-X IIs 505 x-ray requires continued operation during power mains interruptions, it is recommended that the PHOT-X IIs 505 x-ray be powered from an uninterruptible power supply or a battery.
Power frequency (50/60 Hz) magnetic field IEC 61000-4-8	3 A/m	0.3 A/m	Power frequency magnetic fields should be at levels characteristic of a typical location in a typical commercial or hospital environment.
NOTE U_T is the a.c. mains voltage prior to applications of the test level.			

Guidance and manufacture's declaration – electromagnetic immunity

The PHOT-X IIs 505 x-ray is intended for use in the electromagnetic environment specified below. The customer or the user of the PHOT-X IIs 505 x-ray should assure that it is used in such an environment.

Immunity test	IEC 60601 test level	Compliance level	Electromagnetic environment - guidance
Conducted RF IEC 61000-4-6	3 Vrms 150 kHz to 80 MHz outside ISM bands ^a	3 Vrms	Portable and mobile RF communications equipment should be used no closer to any part of the PHOT-X IIs 505 x-ray, including cables, than the recommended separation distance calculated from the equation applications to the Frequency of the transmitter. Recommended separation distance $d = 1.2\sqrt{P}$
Radiated RF IEC 61000-4-3	3V/m 80 MHz to 2.5 GHz	3 V/m	$d = 1.2\sqrt{P}$ 80 MHz to 800 MHz $d = 2.3\sqrt{P}$ 800 MHz to 2.5 GHz Where P is the maximum output power rating of the transmitter in watts (W) according to the transmitter manufacturer and d is the recommended separation distance in metres (m). Field strengths from fixed RF transmitters, as determined by an electromagnetic site survey, ^a should be less than the compliance level in each frequency range. ^b Interference may occur in the vicinity of equipment marked with the following symbol: 

NOTE 1 At 80 MHz and 800MHz, the higher frequency range applies.

NOTE 2 These guidelines may not apply in all situations. Electromagnetic propagation is affected by adsorption and reflection from structures, objects and people.

- a Field strengths from fixed transmitters, such as base stations for radio (cellular/cordless) **telephones and land** mobile radios, amateur radio, AM and FM radio broadcast and TV broadcast cannot be predicted theoretically with accuracy. To assess the electromagnetic environment due to fixed RF transmitters, an electromagnetic site survey should be considered. If the measured field strength in the location in which the PHOT-X IIs 505 x-ray is used exceeds the applicable RF compliance level above, the PHOT-XIIs 505 x-ray should be observed to verify normal operation. If abnormal performance is observed, additional measures may be necessary, such as reorienting or relocating the PHOT-X IIs 505 x-ray.
- b Over the frequency range 150 kHz to 80 MHz, field strengths should be less than 3V/m.

Essential performance (purpose of IMMUNITY testing)

Unless the exposure switch is pressed, x-ray is not exposed.

**Recommended separation distances between
Portable and mobile RF communications equipment and the PHOT-X IIs 505 x-ray**

The PHOT-X IIs 505 x-ray is intended for use in an electromagnetic environment in which radiated RF disturbances are controlled. The customer or the user of the PHOT-X IIs 505 x-ray can help prevent electromagnetic interference by maintaining a minimum distance between portable and mobile RF communications equipment (transmitters) and the PHOT-X IIs 505 x-ray as recommended below, according to the maximum output power of the communications equipment.

Rated maximum output power of transmitter W	Separation distance according to frequency of transmitter m		
	150 kHz to 80 MHz $d = 1.2\sqrt{P}$	80 MHz to 800 MHz $d = 1.2\sqrt{P}$	800 MHz to 2.5 GHz $d = 2.3\sqrt{P}$
0.01	0.12	0.12	0.23
0.1	0.38	0.38	0.73
1	1.2	1.2	2.3
10	3.8	3.8	7.3
100	12	12	23

For transmitters rated at a maximum output power not listed above, the recommended separation distance d in metres (m) can be estimated using the equation applicable to the frequency of the transmitter, where P is the maximum output power rating of the transmitter in watts (W) according to the transmitter manufacturer.

NOTE 1 At 80 MHz and 800MHz, the separation distance for the higher frequency range applies.

NOTE 2 These guidelines may not apply in all situations. Electromagnetic propagation is affected by adsorption and reflection from structures, objects and people.

[14] LABEL LOCATION

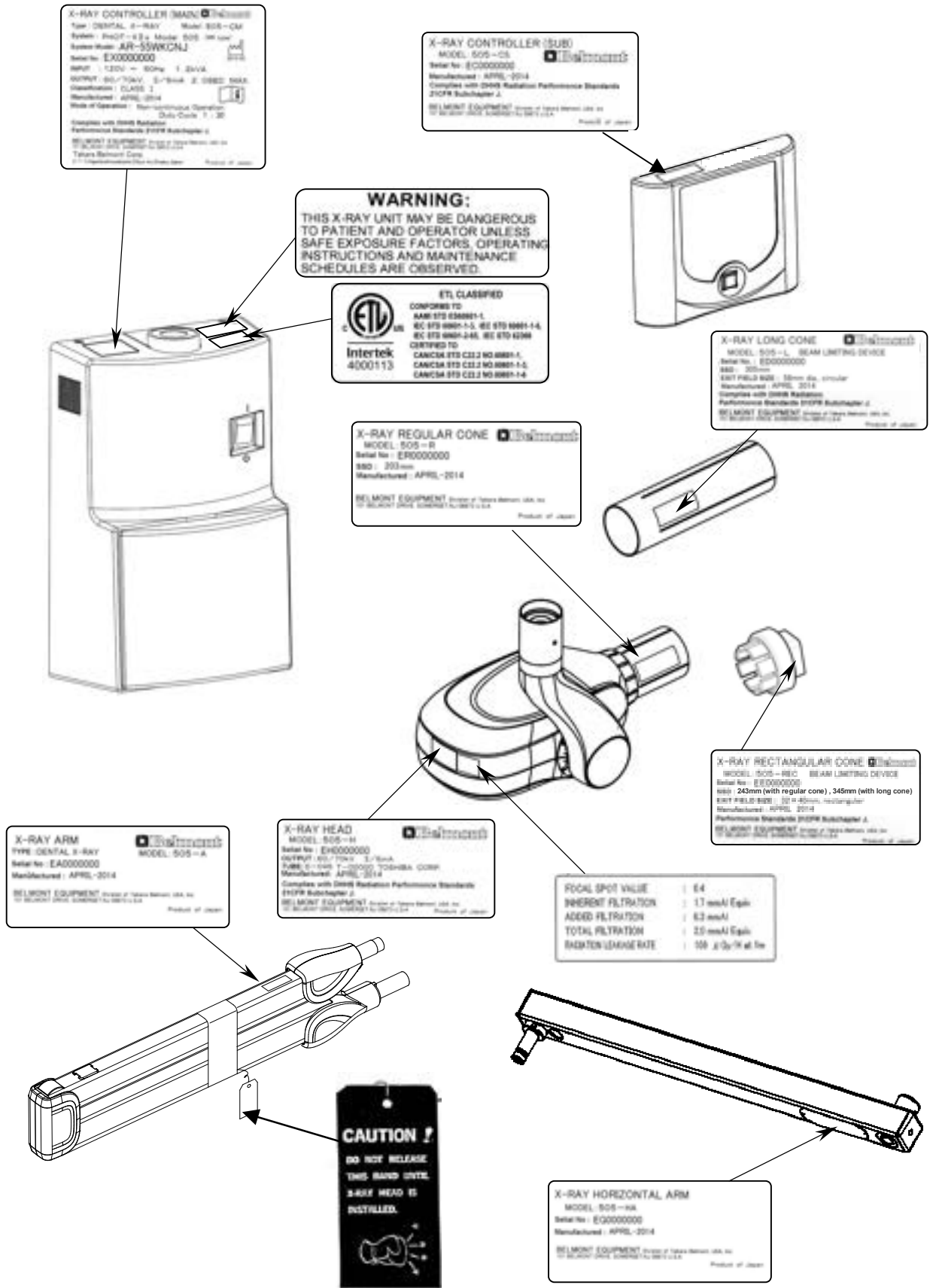

NOTE



BELMONT EQUIPMENT, Division of Takara Belmont, USA, Inc.

101 Belmont Drive Somerset, New Jersey 08873 U.S.A. TEL.:(732) 469-5000 / (800) 223-1192
www.belmontequip.com Fax.:(732)526-6322 / (800) 280-7504

Book No. 1A0ES5G0

Printed in Japan 201603