

PHOT-X IIS

Model 505

DENTAL X-RAY

LCD

OPERATOR'S INSTRUCTIONS (for USA)

Wall Mount Type.....WK

⚠ WARNING

This X-ray equipment may be dangerous to patient and operator unless safe exposure factors, operating instructions and maintenance schedules are observed.

⚠ CAUTION

Federal law restricts this device to sale by or on the order of a dentist.

 **Belmont[®]**

INDEX

	Page
[1] INTRODUCTION -----	1
[2] LAYOUT OF CONTROLS -----	3
[3] FUNCTION OF CONTROLS -----	4
[4] OPERATING PROCEDURES -----	8
[5] SETTING MODE -----	9
[6] OPTIONAL HAND EXPOSURE SWITCH -----	10
[7] DIGITAL IMAGING SYSTEM -----	11
[8] DISINFECTION AND CLEANING -----	11
[9] ERROR CODES -----	12
[10] MAINTENANCE -----	13
[11] TECHNICAL DATA-----	15
[12] PHYSICAL DIMENSIONS-----	16
[13] LABEL LOCATION -----	17
[14] ELECTROMAGNETIC COMPATIBILITY (EMC)-----	18
[15] DISPOSAL -----	20

[1] INTRODUCTION

1. GENERAL

This manual provides information for the operation and maintenance procedures and technical specifications for the PHOT-X IIs Model 505 dental x-ray. The instructions contained in this book should be thoroughly read and understood before operation.

The PHOT-X IIs Model 505 has no user serviceable items. Repair should be performed by qualified dealer service personnel.

Installation, assembly, calibration and certification procedures are written in the separate manual titled "Installation Instructions". Both "Operator's Instructions" and "Installation Instructions" are included in each PHOT-X IIs model 505 package.

2. INTENDED USE OF THE PRODUCT

The PHOT-X IIs Model 505 is an extraoral source dental radiographic x-ray unit. This unit works as diagnostic purpose x-ray source for human teeth with resultant image recorded on intraoral dental x-ray film or image receptor.

3. PARTS IDENTIFICATION OF X-RAY SYSTEM "PHOT-X IIs Model 505"

- a. Tube housing assembly : 505-H
- b. X-ray controls : 505-CM (main controller), 505-CS (sub controller)
- c. Cones : 505-R (regular), 505-L (long)
- d. Collimator : 505-REC (rectangular)
- e. Balance arm : 505-A

4. COMPLIANCE WITH STANDARD

The BELMONT PHOT-X IIs Model 505 x-ray unit complies with the following standard.

- a. Electrical and Mechanical Safety
IEC 60601-1:2005+A1;A2, IEC 60601-1-2:2014+A1, IEC 60601-2-65:2012 Ed.1+A1,
AMMI ES60601-1:2005+A1;A2, IEC 60601-1-6:2010 Ed.3+A1;A2,
- b. Radiation Safety
21 CFR 1020.30, IEC 60601-1-3:2008 Ed.2+A1,

5. CLASSIFICATION









































5-1. According to Section 513 of Federal Food, Drug and Cosmetic Act and 21 CFR Part 806, the BELMONT PHOT-X IIs Model 505 is classified as CLASS II Medical Device.

5-2. According to IEC 60601-1, the BELMONT PHOT-X IIs Model 505 is classified as follows.

- a. Protection against electric shock : Class I Equipment
- b. Protection against ingress of water : Ordinary
- c. Mode of operation : Non continuous (Duty Cycle = 1 : 30)
- d. Equipment not suitable for use in the presence of a flammable anesthetic mixture with air or with oxygen or nitrous oxide.

6. SYMBOL

In this book, on the labels or on the control panel of the PHOT- X IIs Model 505, following symbols are used. Confirm the meaning of each symbol.

 *1	Follow Instructions for use		Date of Manufacture		ON (Power)		OFF (Power)
	Protection Grounding		Exposure Switch		X-ray Emission		Ready
	Maxillary Incisor		Maxillary Cuspid & Pre Molar		Maxillary Molar		Maxillary Occlusal
	Mandibular Incisor		Mandibular Cuspid & Pre Molar		Mandibular Molar		Mandibular Occlusal
	Bite Wing (Incisor & Pre Molar)		Bite Wing (Molar)		Short Cone		Long Cone
	Patient Child		Patient Adult		Patient Large Adult		Brightness of Backlight
	Non-ionizing Radiation		Loudness of Speaker		Mute		Level Control
	Setting Mode		Store to Memory		Turn down		Turn up
	Film		Digital Sensor		Phosphor Plate		Delete
	Decrease		Increase		Return		Max. ON: 2 sec. Min. OFF: 12 sec.

*1 : The color of black part is blue in the actual label.

7. SAFETY

This X-ray Unit may be dangerous to patient and operator, if safe exposure factors, operating instructions and maintenance schedules are not observed. Only qualified and authorized personnel may operate this equipment observing all laws and regulations concerning protection against x-ray radiation.

The operator must :

- have means for audio and visual communication with the patient.
- have full view of kV, mA, timer selections and exposure warning indication.
- be at least 2 m away from the x-ray head and patient and out of the path of the x-ray beam or be positioned behind a protective device.
- fully use all radiation protection devices, accessories and procedures available to protect the patient and operator from x-ray radiation.

WARNING

- **California proposition 65**

Cancer and Reproductive Harm - www.P65Warnings.ca.gov.

- State of California Regulations - Best Management Practices for Perchlorate material CR coin lithium battery build into LCD sub controller contains Perchlorate material - special handling may apply. See www.dtsc.ca.gov/hazardouswaste/perchlorate.

[2] LAYOUT OF CONTROLS

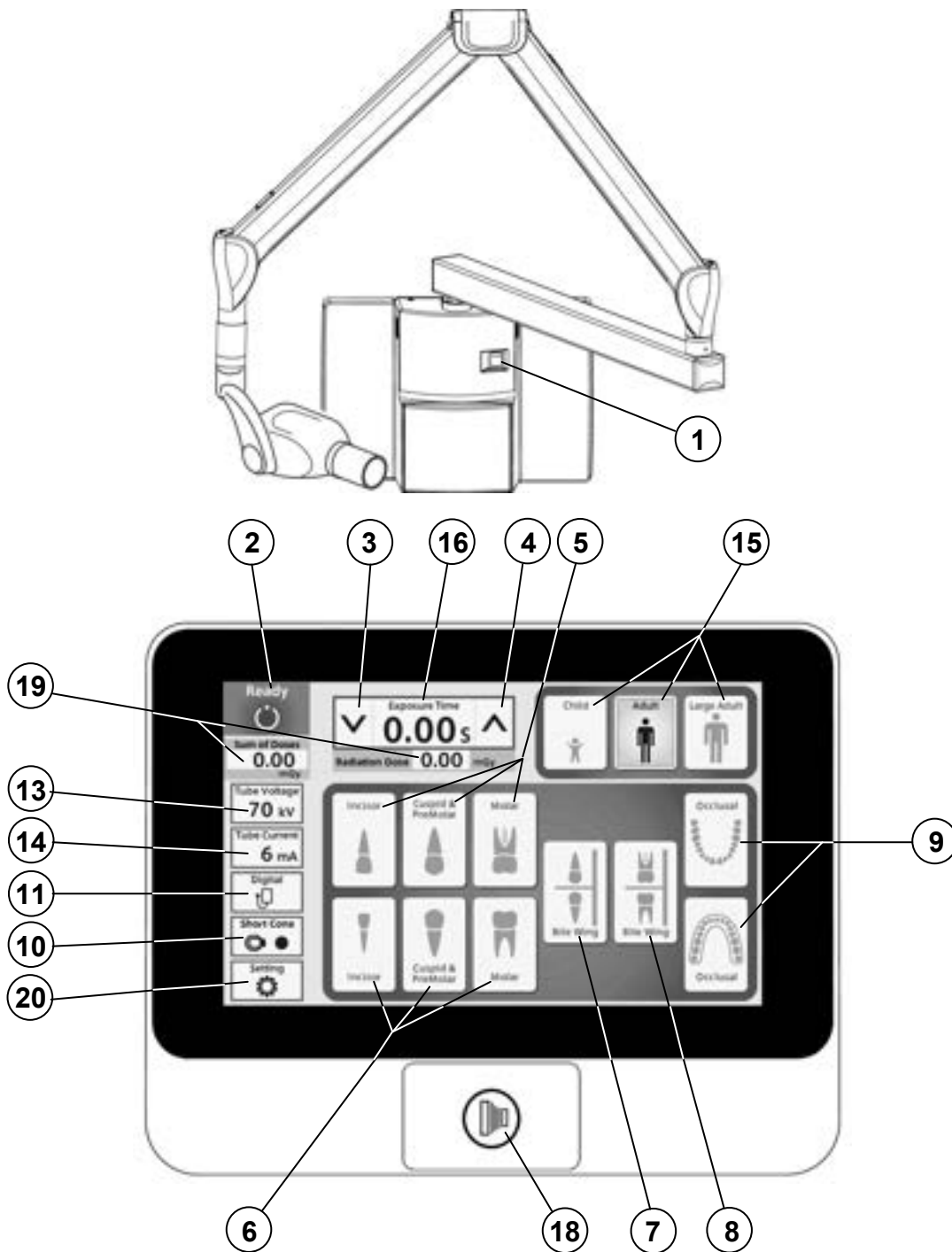

- | | |
|--|--|
| ① Main Power Switch | ⑪ Image Receptor Selection Switch |
| ② Ready Indication | ⑫ is intentionally omitted |
| ③ Exposure Time Adjustment Switch (Down) | ⑬ kV Selection Switch |
| ④ Exposure Time Adjustment Switch (Up) | ⑭ mA Selection Switch |
| ⑤ Tooth Selection Switch (Maxilla) | ⑮ Patient Size Selection Switch |
| ⑥ Tooth Selection Switch (Mandible) | ⑯ Exposure Time Display Window |
| ⑦ Tooth Selection Switch (Bitewing) | ⑰ Exposure Warning Indication (on the next page) |
| ⑧ Tooth Selection Switch (Bitewing Molars) | ⑱ Exposure Switch |
| ⑨ Tooth Selection Switch (Occlusal) | ⑲ Radiation Dose Indication |
| ⑩ Cone Type Selection Switch | ⑳ Setting Mode Switch |

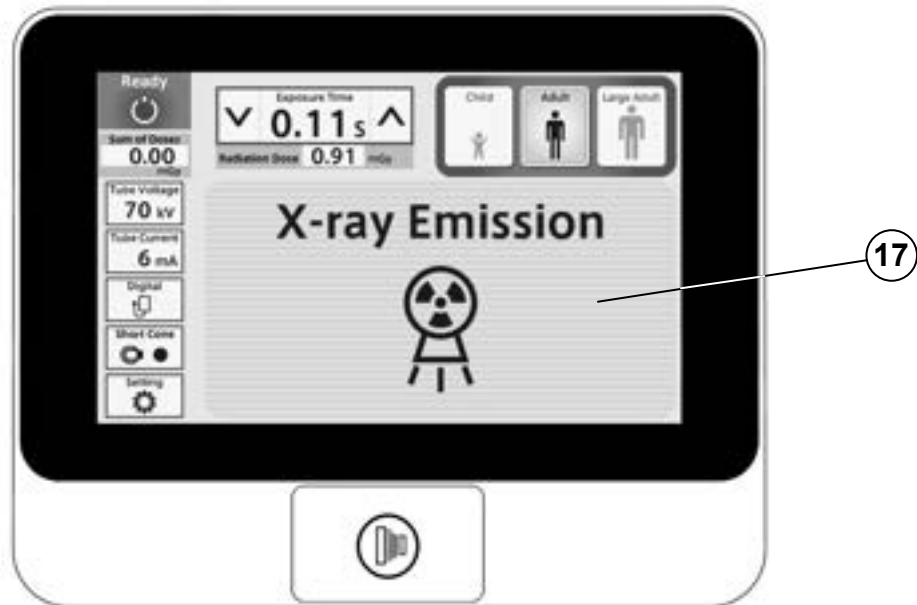

[2] FUNCTION OF CONTROLS



① Main Power Switch

Pushing the upper side of this switch to the ON position energizes the x-ray unit.

② Ready Indication

This indication becomes green when the exposure time is set and the line voltage is within operable range (108 ~ 132Vac). When this indication is white, exposure cannot be made.

③④ Exposure Time Adjusting Switches

By momentarily touching the  (or ) switch, the exposure time displayed increases (or decreases) by one increment. By keeping the switch touched more than 2 sec., the exposure time displayed increases (or decreases) continuously until the switch is released. PHOT-X IIs Model 505 has the following 37 exposure time settings:

0.00, 0.01, 0.02, 0.03, 0.04, 0.05, 0.06, 0.07, 0.08, 0.09, 0.10, 0.11, 0.13, 0.14, 0.16, 0.18, 0.20, 0.22, 0.25, 0.28, 0.32, 0.36, 0.40, 0.45, 0.50, 0.56, 0.63, 0.71, 0.80, 0.90, 1.00, 1.12, 1.25, 1.40, 1.60, 1.80, 2.00 (sec.)

⑤~⑨ Tooth Selection Switches

Touching one of these switches sets the exposure time to the optimum value according to the tooth type and the following settings (⑩~⑮). Selected tooth is illuminated in orange.

- ⑤ Maxilla : Incisor, Cuspid & Premolar or Molar
- ⑥ Mandible : Incisor, Cuspid & Premolar or Molar
- ⑦ Bitewing : Incisor and Cuspid & Premolar
- ⑧ Bitewing : Molar
- ⑨ Occlusal : Maxilla and Mandible

If Incisor of Mandible switch is touched more than 3 sec., unit goes into the screen saver mode and touch switch is disabled. To return to normal mode, touch any part on the LCD screen more than 3 sec.

⑩ Cone Type Selection Switch

This switch indicates the cone type being selected at the time. Momentarily touching this switch will open the cone type selection window. This window closes when one of cones is selected.

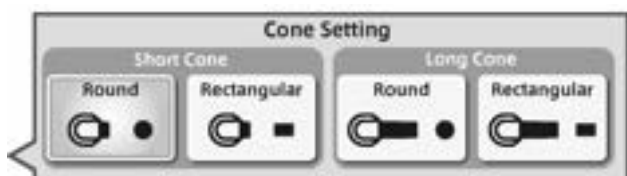

Cone type Selection windows

⑪ Image Receptor Selection Switch

To get optimal images the exposure timer adjustment according to the sensitivity of image receptor is important.

The PHOT-X IIs has 16 density settings for each three kinds of image receptors, i.e.

film, digital sensor and phosphor plate. For film, two different sensitivities can be selected as film-a and film-b and those can be switched easily.

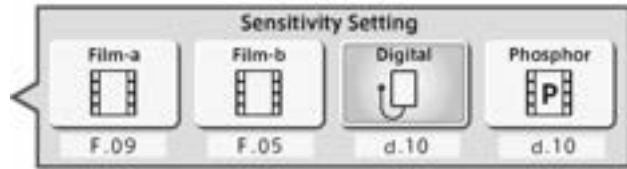

Image Receptor Selection windows

(1) Film

Following two speed (=sensitivity) settings are pre-set at the factory.

a = Film speed No. F.09 (equivalent to ISO speed group "D", or Kodak Ultra-Speed film)

b = Film speed No. F.05 (equivalent to ISO speed group "F/E", or Kodak InSight film)

Including these two speeds, the PHOT-X IIs Model 505 x-ray can provide 16 different film speeds (F.00 ~ F.15) and any two of them can be programmed as film-a and film-b.

Film speed number being selected at the time can be confirmed by touching switch ⑪.

If doctor uses a different film speed, or prefers darker (or lighter) radiographs, the new speed can be programmed as follows. Larger speed number makes films darker. If film speed number is increased by 1, exposure time becomes 25 % longer. The method to change the film speed setting is as follows.

1. Go to the setting mode by touching the switch ⑳.
2. Select "Image receptor sensitivity setting" at page 2/3 in "Setting mode".
3. If new film is used, select the "Preset setting", select "film-a" or "film-b" and select the manufacturer and model name of the film.
4. If darker (or lighter) radiographs are preferred or film name is not listed in "Preset setting", select the "Manual setting" and by touching Ⓐ or Ⓑ switch, increase or decrease film speed until the desired number is displayed. Touch the memory icon to store the setting.

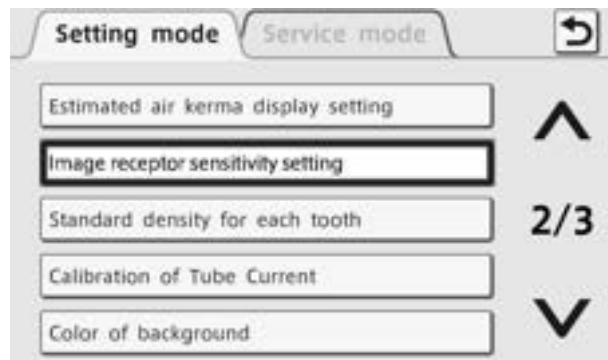
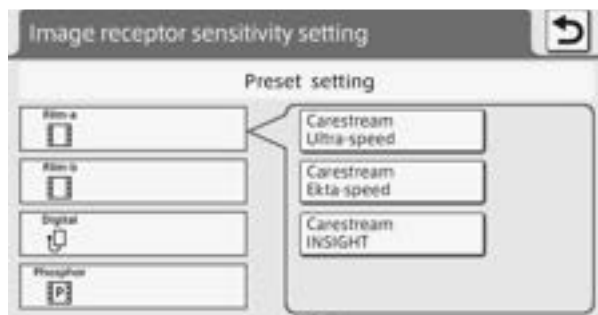

Image Receptor sensitivity setting

(2) Digital sensor and Phosphor Plate

If a digital imaging system is used, shorter exposure time is often required compared with film. PHOT-X IIs has 16 speeds for digital sensor and phosphor plate (d.00 ~ d.15).

Factory settings for digital sensor and phosphor plate are both d.10, but it is necessary to change according to the sensitivity of each model of digital sensor or phosphor plate. The density number selected can be checked by touching switch ⑪. The method to change the density setting for digital sensors or phosphor plate is same as film.



Preset setting mode

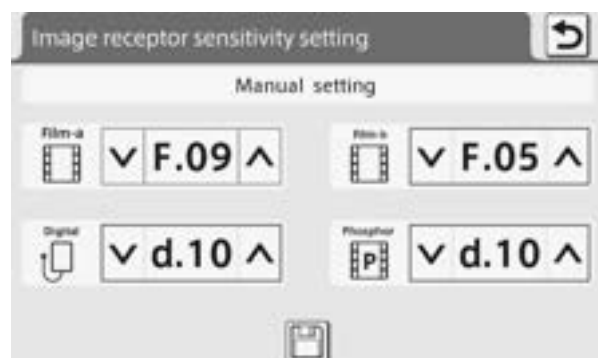

Manual setting mode

TABLE 1. Speed Setting and Exposure Time (Short Cone) [unit : sec.]

Speed Setting	kV	mA	Child					Adult					Large Adult				
			T1	T2	T3	T4	T5	T1	T2	T3	T4	T5	T1	T2	T3	T4	T5
F. 09	60	3	0.20	0.25	0.28	0.32	0.50	0.32	0.40	0.50	0.56	0.80	0.40	0.50	0.63	0.71	1.00
		6	0.10	0.11	0.14	0.16	0.25	0.16	0.20	0.25	0.28	0.40	0.20	0.25	0.28	0.36	0.50
	70	3	0.14	0.16	0.20	0.22	0.36	0.25	0.28	0.36	0.40	0.56	0.28	0.36	0.45	0.50	0.71
		6	0.07	0.08	0.10	0.11	0.18	0.11	0.14	0.18	0.20	0.28	0.14	0.18	0.22	0.25	0.36
F. 05	60	3	0.08	0.10	0.11	0.14	0.20	0.14	0.16	0.20	0.22	0.32	0.18	0.20	0.25	0.28	0.40
		6	0.04	0.05	0.06	0.07	0.10	0.07	0.08	0.10	0.11	0.16	0.09	0.10	0.13	0.14	0.20
	70	3	0.06	0.07	0.08	0.10	0.14	0.10	0.11	0.14	0.16	0.25	0.13	0.14	0.18	0.20	0.28
		6	0.03	0.04	0.04	0.05	0.07	0.05	0.06	0.07	0.08	0.11	0.06	0.07	0.09	0.10	0.14
d.10	60	3	0.13	0.14	0.18	0.20	0.28	0.20	0.25	0.28	0.36	0.50	0.25	0.32	0.36	0.40	0.63
		6	0.06	0.07	0.09	0.10	0.14	0.10	0.13	0.14	0.16	0.25	0.13	0.16	0.18	0.22	0.32
	70	3	0.09	0.11	0.13	0.14	0.22	0.14	0.18	0.22	0.25	0.36	0.18	0.22	0.25	0.32	0.45
		6	0.04	0.05	0.06	0.07	0.11	0.07	0.09	0.11	0.13	0.18	0.09	0.11	0.13	0.16	0.22

TABLE 2. Speed Setting and Exposure Time (Long Cone) [unit : sec.]

Speed Setting	kV	mA	Child					Adult					Large Adult				
			T1	T2	T3	T4	T5	T1	T2	T3	T4	T5	T1	T2	T3	T4	T5
F. 09	60	3	0.40	0.50	0.63	0.71	1.00	0.71	0.80	1.00	1.12	1.60	0.90	1.00	1.25	1.40	2.00
		6	0.20	0.25	0.28	0.36	0.50	0.36	0.40	0.50	0.56	0.80	0.45	0.50	0.63	0.71	1.00
	70	3	0.28	0.36	0.45	0.50	0.71	0.50	0.56	0.71	0.80	1.25	0.63	0.71	0.90	1.00	1.40
		6	0.14	0.18	0.22	0.25	0.36	0.25	0.28	0.36	0.40	0.56	0.32	0.36	0.45	0.50	0.71
F. 05	60	3	0.18	0.20	0.25	0.28	0.40	0.28	0.36	0.40	0.45	0.71	0.36	0.45	0.50	0.56	0.90
		6	0.09	0.10	0.13	0.14	0.20	0.14	0.18	0.20	0.25	0.36	0.18	0.22	0.25	0.28	0.45
	70	3	0.13	0.14	0.18	0.20	0.28	0.20	0.25	0.28	0.32	0.50	0.25	0.32	0.36	0.40	0.63
		6	0.06	0.07	0.09	0.10	0.14	0.10	0.13	0.14	0.16	0.25	0.13	0.16	0.18	0.22	0.32
d.10	60	3	0.25	0.32	0.36	0.45	0.63	0.45	0.50	0.63	0.71	1.00	0.56	0.63	0.80	0.90	1.25
		6	0.13	0.16	0.18	0.22	0.32	0.22	0.25	0.32	0.36	0.50	0.28	0.32	0.40	0.45	0.63
	70	3	0.18	0.22	0.28	0.32	0.45	0.32	0.36	0.45	0.50	0.71	0.40	0.45	0.56	0.63	0.90
		6	0.09	0.11	0.13	0.16	0.22	0.16	0.18	0.22	0.25	0.36	0.20	0.22	0.28	0.32	0.45

⑬ kV Selection Switch

Momentarily touching this switch will open the kV selection window. This window closes when either 60 or 70 kV is selected.

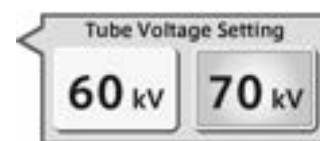

KV Selection Window



⑭ mA Selection Switch



Momentarily touching this switch will open the mA selection window. This window closes when either 3 or 6 mA is selected.



mA Selection Window

⑮ Patient Selection Switch

These switches alter the selection of patient type/size to be radiographed (child, adult or large adult) and sets the exposure time automatically. If the weight of child is less than 20kg, touch  switch once after setting to child. If the weight of child is over 50kg and less than 70kg, touch  switch twice after setting to child. If the weight of child is over 70kg, set to adult.

NOTE: Setting or adjusting the exposure time manually (with  or  switch) supersedes ⑤ ~ ⑮ functions.

⑯ Exposure Time Display Window

This window displays the selected exposure time.

⑰ Exposure Warning Indication

This indication appears while the unit is producing x-radiation.

⑱ Exposure Switch

This switch initiates radiographic exposure. When making an exposure, depress and hold this switch until the Exposure Warning Indication (⑰) and the audible warning shut off. Failure to keep this switch depressed will result in the premature termination of the exposure and an error code E.00 will be displayed.

①⑨ Radiation Dose Indication

Estimated air kerma (radiation dose) at distal end of cone can be displayed below the exposure time display window. This value is calculated by kV, mA, exposure time and cone type selected at the moment. The value displayed below the ready indication is sum of estimated air kerma of each exposure after the power switch has been turned on.

The units of these values can be selected from mGy or mGycm². And also to display these values or not can be selected by the following procedures.

1. Go to the setting mode by touching switch ②⑩.
2. Select “Estimated air kerma display setting” at 2/3 page of setting mode.
3. Select “Display ON” or “Display OFF”.
4. If “Display ON” is selected, you can select “mGy” or “mGycm²” on next menu.

②⑩ Setting Mode Switch

By touching this switch the normal operation mode will be changed to the setting mode or service mode. At the setting mode, following settings can be changed. Refer to section [5] for detail. Service mode is restricted to the qualified dealer service personnel and requires password.

Page 1/3: Parameter selection at power ON

- Volume control
- Brightness of LCD
- Sensitivity of touch panel
- Language selection

Page 2/3: Estimated air kerma display setting

- Image receptor sensitivity setting
- Standard density for each tooth
- Calibration of tube current
- Color of background

Page 3/3: Screen saver setting

- Nameplate setting
- Photo display setting

[4] OPERATING PROCEDURES

1. Turn ON the Main Power Switch (1).

NOTE : Do not turn on the main power switch while touching the LCD screen, as the touch sensor initializes the sensitivity when the power is turned on.

2. Select the appropriate tooth type (5 ~ 9), and confirm the pre-selected conditions (cone type, film or digital, kV, mA and patient size) are suitable for exposure.

NOTE : To manually set the exposure time, depress either of the Manual Exposure Time Adjusting Switches (▲ or ▼) until the desired exposure time appears in the Exposure Time Display Window (16). While the unit is in manual mode, other selection switches (5 ~ 15) do not affect exposure time. (All of the tooth selection switches are white.) To return to the automatic exposure time selection mode, depress any one of Tooth Selection Switches (5 ~ 9).

3. Confirm that Ready Indication (2) is illuminated on green.

NOTE : The ready indication will not illuminate unless the incoming line voltage is correct and within the x-ray's operable range (108 ~ 132Vac).

4. Set the image receptor in the patient's mouth and position the x-ray tubehead using the standard positioning procedures.

5. Depress the Exposure Switch (18). When the Exposure Switch is depressed, the Exp. Warning Indication (17) appears and the audible warning sounds. Do not release the Exposure Switch until the Exposure Warning Indication and audible warning automatically shut off. Failure to keep the switch depressed will result in exposure being terminated prematurely.

6. To continue to radiograph other teeth, just select appropriate Tooth Selection Switches (5 ~ 9).

IMPORTANT : To protect x-ray tube head from heat accumulation, wait for a time interval that is equal to 30 times the selected exposure time before making additional exposures. (Example : a 15 sec. wait is necessary between exposures that are 0.5 sec. in duration.)

7. Turn OFF the Main Power Switch (1) in order to prevent accidental exposures when the unit is not in use.

NOTE : If the unit is left without being operated and the Main Power Switch (1) is kept on, display will go into one of the following four screen saver modes.

- a. Energy saving mode
- b. Fixed display of one photo
- c. Slide-show of photos
- d. Nameplate display

Transition time to the screen saver mode can be set by 5-minute steps and making switch enable or disable during screen saver mode is also selectable.

[5] SETTING MODE

By touching the setting mode switch at bottom left corner, the normal operation mode can be changed to the setting mode or service mode. There are 13 setting modes and each purposes of those settings are as follows.

1. Parameter selection at power ON

Factory default settings are

kV selection : 60 kV

mA selection : 6 mA

Image receptor : Digital sensor

Patient type : Adult

Cone type : Short cone (round)

If necessary, these settings can be changed. For example, in case of pedodontistry, patient type should be changed to Child. For the image receptor, as the sensitivity of each receptor is different, please set the sensitivity as shown page 5.

If the same settings before the power switch is turned off could be set at power on, select "Same Selection before Power OFF".

2. Volume control

Volume of touch screen sound and warning sounds can be adjusted separately. One from 9 levels including off setting can be selected for touch screen sound and one from 3 levels for warning sounds. Warning sounds are for exposure warning and error warning.

3. Brightness of LCD

Brightness for backlight of LCD display can be selected from 10 levels.

4. Sensitivity of touch panel

Sensitivity of touch switch on the panel can be selected from 3 levels.

5. Language Selection

Language can be selected from English, French, Spanish or German.

6. Estimated air kerma display setting

Whether to display the estimated air kerma (radiation output) or not to display can be selected. If displaying is selected, the unit of the values can be selected from mGy or mGycm².

7. Image receptor sensitivity setting

Manual setting or preset setting can be selected.

Manual setting: Two film speeds can be selected from 16 speeds as film-a and film-b. One digital sensor sensitivity can be selected from 16 steps and one phosphor plate sensitivity can be selected from 16 steps. Refer to page 5 for detail.

Preset setting: For each 4 types of image receptors, standard sensitivity can be set by selecting the manufacturer and model name of the image receptor.

8. Standard density for each tooth

The exposure time ratio between each tooth is preprogrammed. This ratio can be changed by this setting. Exposure time for each tooth can be increased (or decreased) by 4 steps individually. One step increase is corresponding to 25% increase of exposure time.

9. Calibration of tube current

Tube current can be adjusted to be the rated value by making several exposures at this mode. This calibration is necessary at the installation and at the annual maintenance checks.

10. Color of background

The default color of the back panel at the normal operation mode is blue. This color can be changed to green or pink. And also there are two patterns for pink.

11. Screen saver setting

If the unit is left without being operated and the main power switch is kept on, display will go into screen saver mode. You can select one of following four kinds of screen saver modes.

- a. Energy saving mode: Backlight of LCD becomes minimum in this mode.
- b. Fixed display of one photo: One of ten photos pre-stored is displayed. You can overwrite your original photos on the pre-stored photos.
- c. Slide-show of photos: ten photos are displayed in turn continuously.
- d. Nameplate display: Any name within 20 characters with a photo is displayed.

Transition time from normal mode to the screen saver mode can be set to 5 ~ 30 minutes in 5-minute steps. Enabling or disabling of touch switch function during screen saver mode is also selectable. If disabling is selected, the operator must hold down any part on the screen for at least 3 seconds to return to normal mode.

12. Nameplate setting

Nameplate creation: Four kinds of nameplates can be created and stored. To check the nameplate already created, touch the mountain icon at right side. To modify or create new name, touch the name or “New Name Input” at left side. Maximum 20 characters can be used for the name of nameplate. After the name is fixed, you can use preinstalled photo or your original photo for that nameplate. If you want to use your own photo, USB flash drive containing your photo data should be connected to the right side connector of LCD controller. The file name of your photo should be the same as indicated on the screen and data format should be 16 bit or 24 bit BMP with 800 x 400 pixels.

Nameplate selection: One of the nameplates created should be selected for the screen saver mode.

13. Photo display setting

Ten photos are pre-stored. One of ten photos is used for “fixed display of one photo” and ten photos are used for “Slide-show of photos” at screen saver mode.

Stored photo can be checked by touching the mountain icon at right side. If you want to store your own photo, touch one of the bar named “FF00” to “FF09”. Connect USB flash drive containing your photo data to the right side connector of LCD controller. The file name of your photo should be the same as indicated on the screen and data format should be 16 bit or 24 bit BMP with 800 x 480 pixels.

[6] OPTIONAL HAND EXPOSURE SWITCH

An optional hand exposure switch can be connected to the sub controller. Since this exposure switch has a coiled cord, operators can stand in the most suitable position for operation. As controller has separate connector for this exposure switch, both exposure switch (18) on the front panel of sub controller and this hand exposure switch can be used. If local code prohibits use of both, ask installer to disconnect the connector of either switch.

[7] DIGITAL IMAGING SYSTEM

No x-ray image receptor is integrated into the PHOT-X IIs Model 505 x-ray system. If an image receptor is used with the PHOT-X IIs Model 505, the type and performance of the receptor should be as follows.

1. Type of receptor : CCD (charge-coupled device), CMOS (complementary metal oxide semiconductor) or PSP (photostimulable phosphor plate) receptor for dental intraoral use.
2. Adequate amount of x-radiation for the receptor should be between 0.02mGy and 23.6mGy.
3. Use the receptor holder and receptor cover recommended by the manufacturer of image receptor.
4. Receptor holder should hold the image receptor firmly in position and work as the x-ray beam alignment device.

WARNING

The use of ACCESSORY equipment not complying with the equivalent safety requirements of the PHOT-X IIs Model 505 may lead to a reduced level of safety of the resulting system.

Consideration relating to the choice shall include :

- use of the accessory in the PATIENT VICINITY
- evidence that the safety certification of the ACCESSORY has been performed in accordance to the appropriate IEC 60601-1 and/or IEC 60601-1 harmonized national standard.

[8] DISINFECTION AND CLEANING

1. DISINFECTION

- (a) X-ray operators are required to wear disposable gloves when taking radiographs and handling contaminated film packets or digital detector cover. Gloves should be changed for each patient to avoid cross contamination. X-ray head, main controller and sub controller should be covered by single use barriers.
- (b) If you use film holders or digital detector holders that go into patient's mouth, properly sterilize them. Follow the sterilization procedures indicated by each manufacturer.

2. CLEANING

In order to ensure proper hygiene and cleaning of the equipment, the following procedures must be followed.

CAUTION

Before cleaning the unit, turn off the main power switch and breaker on the branch line. This is required because some internal parts remain connected to main voltage even when the main power switch has been turned off.

Never use the corrosive disinfectants, such as povidone iodine or sodium hypochlorite.

Do not pour or spray solvent or liquid directly on the x-ray unit.

Be careful not to allow solvents to run or drip into the x-ray unit.

Limitations on reprocessing : Repeated processing has minimal effect on these instruments. End of life is normally determined by wear and damage due to use.

Point of use : Remove excess soil with disposable cloth / paper wipe.

Preparation for cleaning : Turn off the main power switch and breaker on the branch line. Disassembly is not required.

Cleaning : Wipe the outside surface with a paper towel dampened with a disinfectant solution or household, non abrasive cleaner.

Disinfection : To ensure proper cleaning of the parts that may come in contact with skin, periodic disinfection with a non corrosive surface disinfectant is recommended.

Recommended disinfectant : FD333 (Durr Dental)

Drying : Allow surface to air dry before turning breaker and main switch back on.

[9] ERROR CODES

If an abnormal condition exists in the unit, or a malfunction occurs, an error code, code condition, and the possible solution will be displayed on the LCD screen. Please refer to the table below.

Error Code	Condition	Step to be Taken	Possible Solution
E. 00	Exposure switch was released before exposure termination.	All the tooth selection lights blink. Touch one of the tooth switches.	Release the exposure switch after the exposure warning indication disappears.
E. 01	Exposure switch was pressed within 10 sec. of previous exposure.	A 10 sec. delay is built in between each exposures and 3 sec. delay is built in after the power is on.	There should be a "wait" interval of 30 times the exposure time between successive exposures.
	Exposure time was set and exposure switch was pressed within 3 sec. after the power switch being turned on.		Wait for a minimum 3 sec. after the main power switch is turned on before pressing the exposure switch.
E. 02	Line voltage was less than 90% of rated voltage.	Line voltage should be in the range of $\pm 10\%$ of rated voltage.	Confirm that ready lamp is on before exposure. Ask service personnel to check the line voltage.
E. 03	Line voltage was more than 110% of rated voltage.		
E. 05	Tube current at last portion of exposure was less than 2 mA at 3 mA setting or less than 4.5 mA at 6 mA setting	Turn off the main power switch and wait for approximately 2 min. Turn on the main power switch again.	If same error code is displayed, call service personnel.
E. 06	Tube current at last portion of exposure was more than 4 mA at 3 mA setting or more than 7.5 mA at 6 mA setting		
E. 07	During the exposure, tube current becomes less than 1.5 mA at 3mA setting or less than 3 mA at 6 mA setting.		
E. 08	During the exposure, tube current becomes more than 14 mA.		
E. 09	Setting for pre-heating time is out of range.		
E. 10	Exposure switch or exposure circuit had been ON, when main power switch is turned on.		
E. 11	Tube current is detected during pre-heating period.		
E. 12	Tube current is detected when main power switch is turned on.		
E. 14	Tube potential at last portion of exposure was less than 50 kV at 60 kV setting or less than 60 kV at 70 kV setting.		
E. 15	Tube Potential at last portion of exposure was more than 70 kV at 60 kV setting.		

Error Code	Condition	Step to be Taken	Possible Solution
E. 16	1. During the exposure, tube potential becomes less than 40 kV at 60 kV setting or less than 50 kV at 70 kV setting. 2. 2P connector between the main power board and arm or between the arm and tube head is disconnected.	Turn off the main power switch and wait for approximately 2 min.	If same error code is displayed, call service personnel.
E. 17	During the exposure, tube potential becomes more than 80 kV.	Turn on the main power switch again.	
E. 18	Excess current was detected in primary circuit of filament transformer.		
E. 19	Excess current was detected in primary circuit of high voltage transformer.		
E. 20	1. Exposure switch was depressed when tube head temperature was over 60 C. 2. 8P connector between the main power board and arm or between the arm and tube head is disconnected.	Wait until the temperature goes down.	
E. 22	Failure of electrical communication between the power PCB and timer PCB.	Turn off the main power switch and wait for approx. 2 min. Turn on power switch again.	
E. 23	Some switch had been on, when the main power switch is turned on. (Except the exposure switch.)		
E. 24	The built-in battery has run out.		
No error	Unable to return to the normal mode from the screen saver mode.	Touch the LCD screen more than 3 seconds. If "switches are still enabled" is selected at the screen saver setting in the setting mode, it is not necessary to press for a long time.	

[10] MAINTENANCE

The PHOT-X IIs Model 505 x-ray unit requires post installation confirmation and periodic maintenance checks to be performed by dealer service personnel. These procedures ensure that the x-ray unit is functioning within the manufacture's specifications and remains in compliance with the Standard.

It is responsibility of the owner of the unit to see that these maintenance checks are correctly performed. The specific instructions to perform these checks are located within the PHOT-X IIs Model 505 Installation manual.

- a. Maintenance personnel : Qualified dealer service personnel who has the experience with Belmont's x-ray or has been trained by Belmont. But item 7 - 10 of the maintenance check list on Page 14 should be verified routinely by treatment room personnel.
- b. Specification of the parameters to be monitored and monitoring frequency : Refer to the maintenance check list on page 14.
- c. Acceptance limit : Refer to the Maintenance check list on page 14.
- d. Required action when failed : Refer to the Maintenance check list on page 14.
- e. Tools to maintain quality control logs : Use the check list on page 14.
- f. Training material : Operator's instructions, Installation manual and Service manual

MAINTENANCE CHECK LIST

Parameter	Acceptance limit	Frequency	Procedures when failed	OK/NG
1. Line voltage	Confirm the line voltage is within 120V±10%. Also confirm the voltage drop during exposure is within 5%.	Yearly	Connect to the power supply within 120V±10%. Check disconnection of wire or connection failure. Repair cable connection as needed.	
2. Tube current	Confirm the measured mA value indicated on the LCD screen is within the rated value ± 1 mA.	Yearly	Perform mA calibration. (Refer to page 26 of Installation manual.)	
3. Tube potential	Confirm the measured kV value indicated on the LCD screen is within the rated value ±10%.	Yearly	Check the tube potential compensation (CP) values are same as the values on the label in the head yoke.	
4. Timer	Confirm the error of the measured value by non-invasive exposure time meter is within ±5% or 20mS at 0.01 and 2.0 seconds exposure. *The non-invasive time meter should be calibrated to measure the radiation from dental x-ray.	Yearly	Exchange the power PC board to new one and check the result.	
5. Wall mounting plate	Confirm the wall plate is firmly fixed to the wall.	Yearly	If bolts are loose, find the reason why bolts became loose and take counter measure that prevents bolts from becoming loose.	
6. Arm mounting bracket	Make sure that the arm bracket is firmly attached to the wall plate.	Yearly	If bolts that fix the arm bracket to the wall plate are loose, find the reason why bolts became loose and take counter measure that prevents bolts from becoming loose.	
7. Dosimetry	Save the image that was taken under appropriate conditions as a reference image. Compare a newly taken image with a reference image to assure the image quality.	Weekly	If the image quality is found poor comparing to a reference image, check the condition of image receptor (film, sensor or imaging plate), image developer (developing fluid, dental film developer, PC or scanner). If they are OK, then set appropriate film / sensor speed by referring to page 5 of this book.	
8. Horizontal arm	Confirm that horizontal arm is firmly inserted to the arm bracket. Make sure the retaining bolt is firmly inserted to the arm bracket.	Daily (before use)	If the retaining bolt is loose, find the reason why bolt became loose and take counter measure that prevents the retaining bolt from becoming loose.	
9. Head	Confirm the head can be smoothly positioned.	Daily (before use)	Adjust the brake screws by referring to page 16 of installation manual.	
10. Balance arm	Confirm the balance arm moves smoothly without making noise.	Daily (before use)	Adjust the tension of the balance arm by referring to page 16 of installation manual. If the balance arm makes noise, apply grease.	

[11] TECHNICAL DATA

1. X-ray tube (Stationary Anode) ----- D-046 or KL11-0.4-70 (See the label on head)
 - a. Nominal focal spot value ----- 0.4 (IEC 60366)
 - b. Target Material ----- Tungsten
 - c. Target angle ----- 12.5 deg (D-046), 12 deg (KL11-0.4-70)
 - d. Maximum anode heat content ----- 4.3 kJ (6.1 kHU)
2. Maximum x-ray tube assembly heat content ----- 293 kJ (413 kHU)
3. Rated peak tube potential ----- 60 kV / 70 kV selectable
4. Rated tube current ----- 3 mA / 6 mA selectable
5. Maximum rated peak tube potential ----- 70 kV
6. Rated line voltage ----- 120 VAC, 60 Hz, Single phase, 1.2 kVA
7. Line voltage range ----- 108 VAC ~ 132 VAC
8. Range of line voltage regulation ----- 0 ~ 5 % (Apparent resistance 0.52 ohm)
9. Rated line current ----- 10 A at 70 kV, 6 mA
10. Maximum line current ----- 11 A at 70 kV, 6 mA
11. Exposure time ----- 0.01 ~ 2.0 sec.
12. Inherent filtration ----- 1.7 mm Al Equivalent
13. Added filtration ----- 0.3 mm Al
14. Minimum filtration permanently in useful beam ----- 2.0 mm Al Equivalent at 70 kV
15. Nominal radiation output

	60 kV		70 kV	
	3 mA	6 mA	3 mA	6 mA
a. Distal end of regular cone -----	4.6	9.1	5.9	11.8 mGy/sec. ± 40%
b. Distal end of long cone -----	2.0	4.1	2.6	5.2 mGy/sec. ± 40%

(Data obtained by direct measurement in the useful beam)
16. Nominal electrical output of H.V. generator ----- 0.42 kW at 70 kV, 6 mA
17. Cone

	Source to skin distance	Field size
a. Regular cone -----	8 inches (203 mm)	58 mm dia., circular
b. Long cone (option) -----	12 inches (305 mm)	58 mm dia., circular
c. Rectangular collimator (option) -----	SSD of cone + 40mm	32 x 40 mm, rectangular
18. Maximum symmetrical radiation field ----- 60 mm dia. at distal end of cone
19. Leaking technique factor ----- 70 kV / 0.19 mA (697mAs at 1 hour)
(0.19 mA is maximum rated continuous current for 6mA with a duty cycle 1:30)
20. Duty cycle ----- 1 : 30 (0.5 sec. exposure with 15 sec. interval)
21. Maximum deviation of tube potential, tube current and exposure time
 - a. Below 0.1 sec. setting ----- ±10 kV, ±2 mA, ±5 msec.
 - b. 0.1 sec. setting & up ----- ±5 kV, ±1 mA, ±10 msec.
22. Measurement base of technique factors
 - a. peak tube potential ----- Average of peak tube potentials during one exposure
 - b. tube current ----- Average of tube current during one exposure
 - c. exposure time ----- Time period during x-ray is emitted
23. Half value layer ----- 1.5 mm Al over
24. Source to the base of cone distance ----- 94 mm
25. Environmental condition for storage ----- -20 ~ 70 °C, 10 ~ 100 %, 500 ~ 1060 hPa
26. Environmental condition for operation ----- 10 ~ 40 °C, 30 ~ 70 %, 700 ~ 1060 hPa
27. Dose area product ----- Estimated air kerma displayed [mGy]
x 26.4 [cm²] (for regular and long cone)
Estimated air kerma displayed [mGy]
x 12.8 [cm²] (for rectangular collimator)

[12] PHYSICAL DIMENSIONS

() = mm

* 8-1/4" is the Pass-Thru Plate Width, if Optional 097PTP is ordered and Housing Side Panels are Removed.

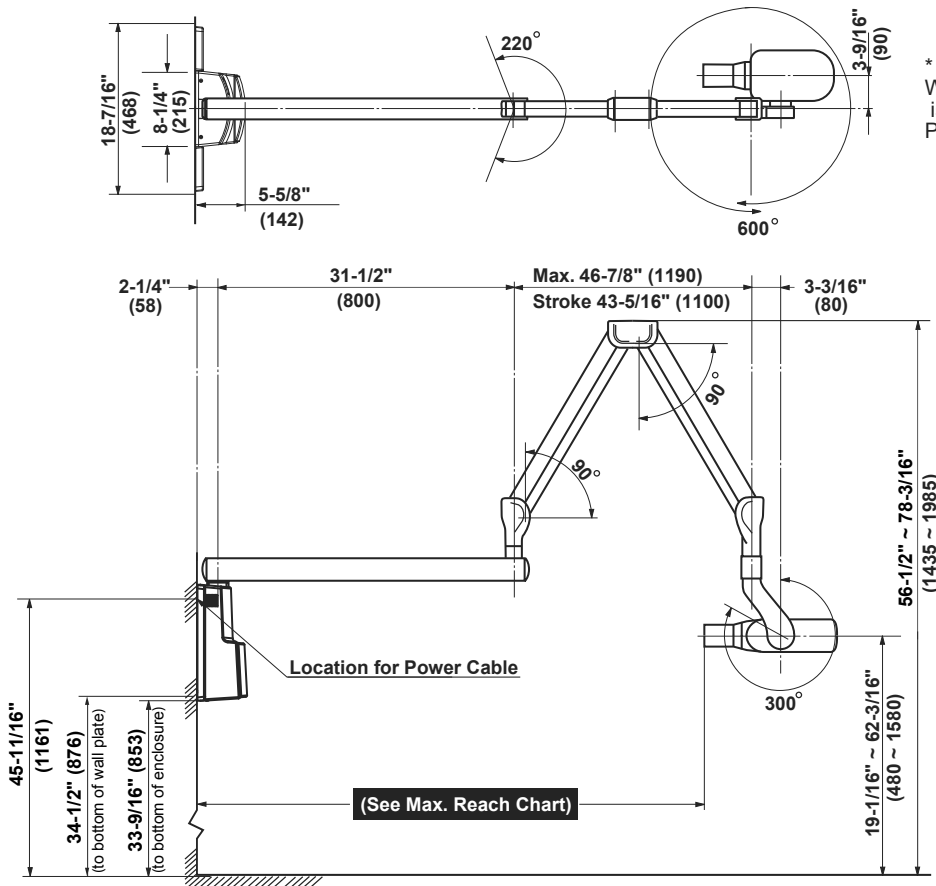

Maximum Reach	
84-1/8" with (2122)	40.0" arm (1000)
75-5/8" with (1922)	31.5" arm (800)
64-1/8" with (1622)	20.0" arm (500)
56-1/8" with (1422)	12.0" arm (300)

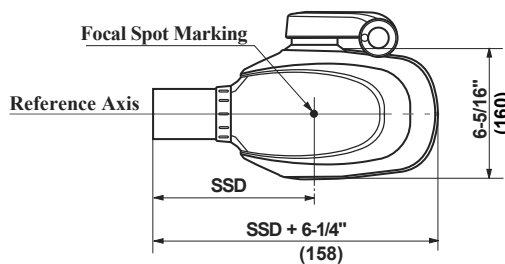
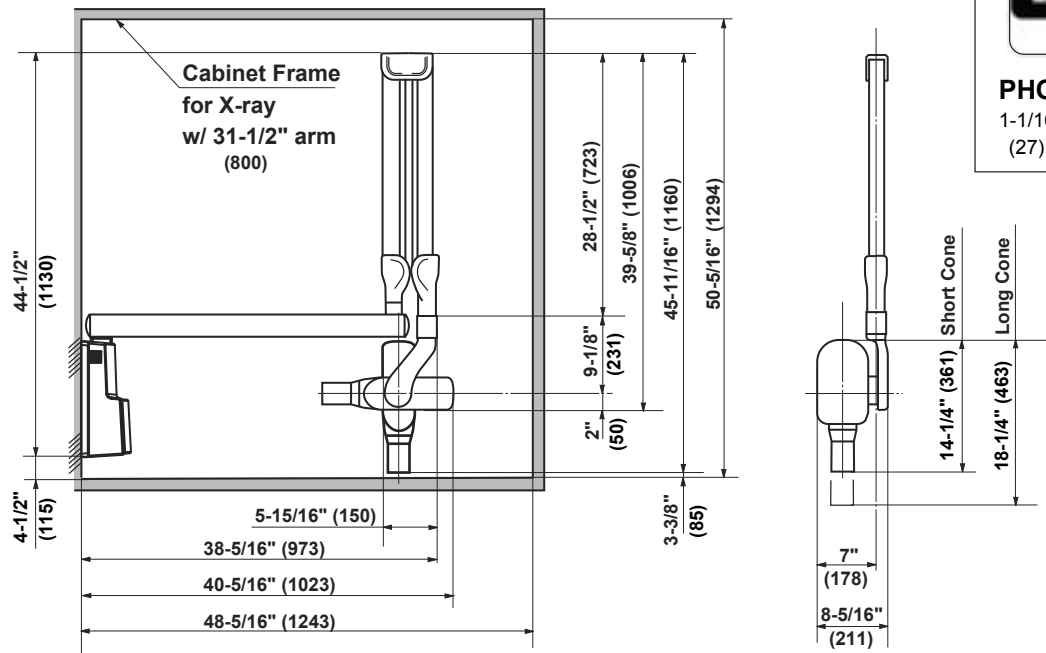
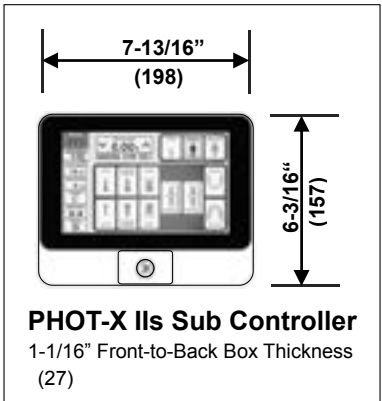

SSD (Source to Skin Distance) :

- Regular cone ----- 8 inches (203mm)
- Long cone ----- 12 inches (305mm)

Note : Installation of rectangular collimator (p/# 1S01WEA0) increases SSD by 40 mm from above value.

Fig. 1-1 Dimensions

[13] LABEL LOCATION

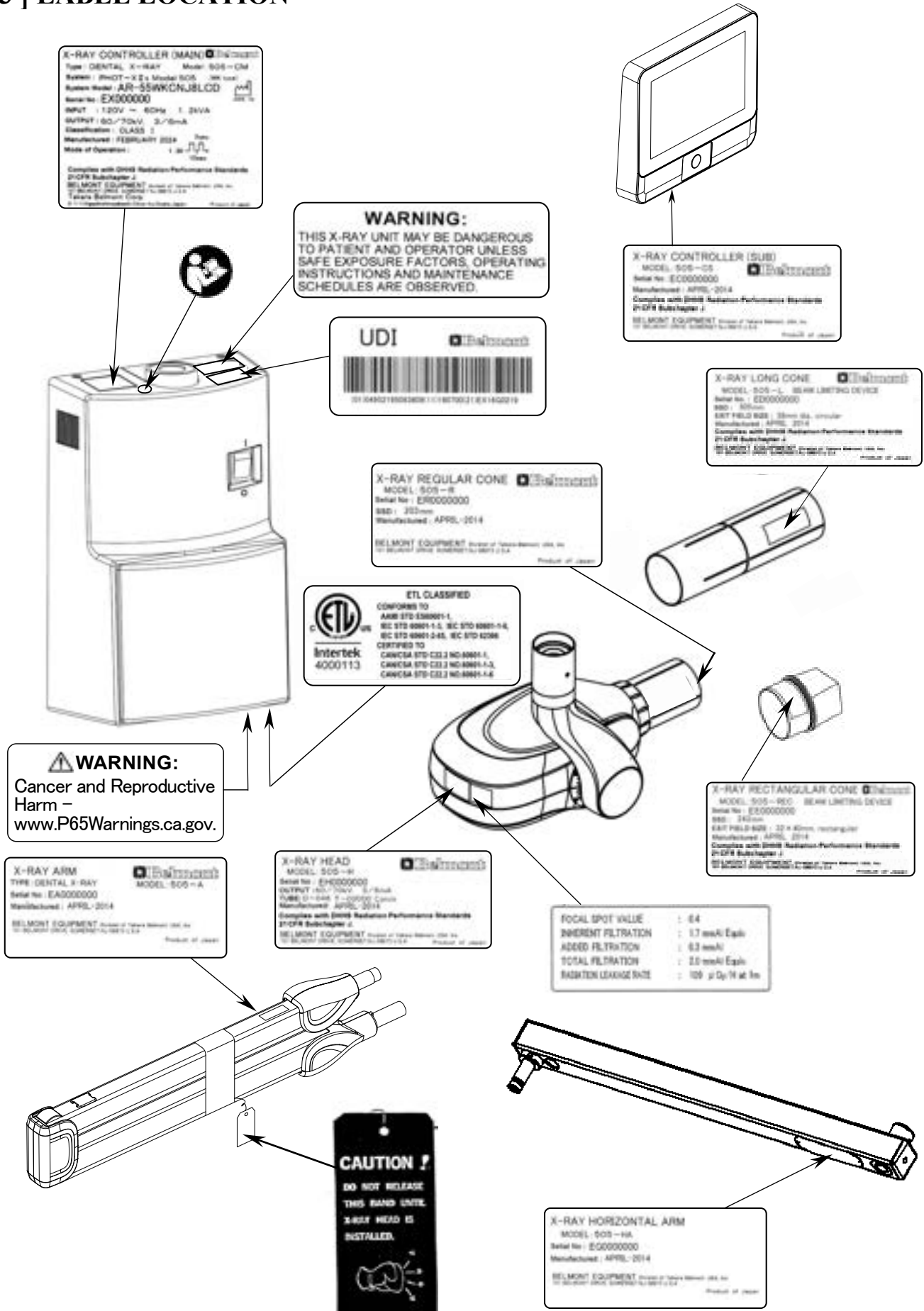

[14] ELECTROMAGNETIC COMPATIBILITY (EMC)

This product conforms to EMC standard IEC 60601-1-2:2014+AMD1:2020.

1. Caution to EMC and Compliance with information in attached document

Medical electrical equipment requires special attention to EMC and it must be installed and used according to the EMC information provided in this instruction manual. Do not install in the vicinity of the electrosurgical device being output or electromagnetically shielded room of ME system for MRI diagnostic imaging because the electromagnetic interference intensity is high.

WARNING

- a. Use of this equipment adjacent to or stocked with other equipment should be avoided because it should result in improper operation. If such use is necessary, this equipment and the other equipment should be observed to verify that they are operating normally.
- b. Use of accessories, transducers and cables other than those specified or provided by the manufacturer of this equipment could result in increased electromagnetic emissions or decreased electromagnetic immunity of this equipment and result in improper operation.
- c. Portable RF communications equipment (including peripherals such as antenna cables and external antennas) should be used no closer than 30cm (12 inches) to any part of the PHOT-X IIs Model 505, including cables specified by the manufacturer. Otherwise, degradation of the performance of this equipment could result.

2. Electromagnetic emissions

Emissions test	Test procedure	Compliance	Note : The emissions characteristics of this equipment make it suitable for use in industrial areas and hospitals (CISPR 11 class A). If it is used in a residential environment (for which CISPR 11 class B is normally required) this equipment might not offer adequate protection to radio-frequency communication services. The user might need to take mitigation measures, such as relocating or re-orienting the equipment.
Conducted and radiated RF emissions	CISPR11	Group 1 Class A	
Harmonic distortion	IEC 61000-3-2	N/A ^(*1)	
Voltage fluctuations and flicker	IEC 61000-3-3	Clause 5	

(*1) : The test is not applicable since professional equipment is rated power 1kW or more.

3. Electromagnetic immunity

Immunity test	IEC 60601 test level	Compliance level	Electromagnetic environment - guidance
Electrostatic discharge (ESD) IEC 61000-4-2	±8 kV contact ±15 kV air	±8 kV contact ±15 kV air	Floors should be wood, concrete or ceramic tile. If floors are covered with synthetic material, the relative humidity should be at least 30%.
Electrical fast transient/burst IEC 61000-4-4	±2 kV for power supply lines ±1 kV for input/output lines	±2 kV for power supply lines ±1 kV for input/output lines	Mains power quality should be that of a typical commercial or hospital environment.
Surge IEC 61000-4-5	±1 kV differential mode ±2 kV common mode	±1 kV differential mode ±2 kV common mode	Mains power quality should be that of a typical commercial or hospital environment.
Power frequency (50/60Hz) magnetic field IEC 61000-4-8	30 A/m	30 A/m	Power frequency magnetic fields should be at levels characteristic of a typical location in a typical commercial or hospital environment.

Immunity test	IEC 60601 test level	Compliance level	Electromagnetic environment -
Proximity magnetic field IEC 61000-4-39	134.2 kHz 65 A/m Pulse Modulation 2.1 kHz 13.56 MHz 7.5 A/m Pulse Modulation 50kHz	134.2 kHz 65 A/m Pulse Modulation 2.1 kHz 13.56 MHz 7.5 A/m Pulse Modulation 50kHz	Proximity magnetic fields should be at levels characteristic of a typical location in a professional healthcare facility environment.
Voltage dips, short interruptions and voltage variations on power supply input lines IEC 61000-4-11	<u>dips</u> 0 %Ut: 0.5 cycle (0,45,90,135,180,225,270 and 315 degree) 0 %Ut: 1 cycle (0 degree) 70 %Ut: 25/30 cycles (0 degree) <u>short interruptions</u> 0 %Ut: 250/300 cycles Ut: Rated voltage of EUT	<u>dips</u> 0 %Ut: 0.5 cycle (0,45,90,135,180,225,270 and 315 degree) 0 %Ut: 1 cycle (0 degree) 70 %Ut: 25/30 cycles (0 degree) <u>short interruptions</u> 0 %Ut: 250/300 cycles Ut: Rated voltage of EUT	Mains power quality should be that of a typical commercial or hospital environment. If the user of the PHOT-X IIs Model 505 x-ray requires continued operation during power mains interruptions, it is recommended that the PHOT-X IIs Model 505 x-ray be powered from an uninterruptible power supply or a battery.
Conducted RF IEC 61000-4-6	AC/DC power and Signal input/output 0.15 MHz - 80 MHz: 3V 6 V in ISM bands between 0.15 MHz - 80 MHz (unmodulated, r.m.s.) 80 % AM (1 kHz)	AC/DC power and Signal input/output 0.15 MHz - 80 MHz: 3V 6 V in ISM bands between 0.15 MHz - 80 MHz (unmodulated, r.m.s.) 80 % AM (1 kHz)	Portable RF communications equipment (including peripherals such as antenna cables and external antennas) should be used no closer than 30cm (12 inches) to any part of the PHOT-X IIs Model 505, including cables specified by the manufacturer. Otherwise, degradation of the performance of this equipment could result.
Radiated RF IEC 61000-4-3	80 MHz - 2700 MHz: 3V/m (unmodulated, r.m.s.) 80 % AM (1kHz)	80 MHz - 2700 MHz: 3V/m (unmodulated, r.m.s.) 80 % AM (1kHz)	
Proximity fields from RF wireless communication equipment IEC 61000-4-3	385 MHz 27 V/m (unmodulated, r.m.s.) Pulse modulation 18 Hz	385 MHz 27 V/m (unmodulated, r.m.s.) Pulse modulation 18 Hz	
	450 MHz 28 V/m (unmodulated, r.m.s.) FM ± 5 kHz deviation 1 kHz sine or Pulse modulation 18 Hz	450 MHz 28 V/m (unmodulated, r.m.s.) FM ± 5 kHz deviation 1 kHz sine or Pulse modulation 18 Hz	
	710 MHz, 745 MHz, 780 MHz 9 V/m (unmodulated, r.m.s.) Pulse modulation 217 Hz	710 MHz, 745 MHz, 780 MHz 9 V/m (unmodulated, r.m.s.) Pulse modulation 217 Hz	
	810 MHz, 870 MHz, 930 MHz 28 V/m (unmodulated, r.m.s.) Pulse modulation 18 Hz	810 MHz, 870 MHz, 930 MHz 28 V/m (unmodulated, r.m.s.) Pulse modulation 18 Hz	
	1720 MHz, 1845 MHz, 1970 MHz 28 V/m (unmodulated, r.m.s.) Pulse modulation 217 Hz	1720 MHz, 1845 MHz, 1970 MHz 28 V/m (unmodulated, r.m.s.) Pulse modulation 217 Hz	
	2450 MHz 28 V/m (unmodulated, r.m.s.) Pulse modulation 217 Hz	2450 MHz 28 V/m (unmodulated, r.m.s.) Pulse modulation 217 Hz	
	5240 MHz, 5500 MHz, 5785 MHz 9 V/m (unmodulated, r.m.s.)	5240 MHz, 5500 MHz, 5785 MHz 9 V/m (unmodulated, r.m.s.)	

4. Essential performance

Unless the exposure switch is pressed, x-ray is not exposed.

If the Essential performance is lost or deteriorated, the device may operate inadvertently and may harm the patient, the operator, and the surrounding people.

[15] DISPOSAL

1. Disposal of x-ray unit or components

The tube head of this x-ray unit contains the lead for x-ray shield and insulation oil, which is refined mineral oil and does not contain the carcinogenic substances such as PCBs.

CR type coin lithium battery build in the LCD sub-controller contains Perchlorate material.

When disposing the x-ray unit or components, appropriately dispose complying with all current applicable regulations and local codes.

For the coin lithium battery, see www.dtsc.ca.gov/hazardouswaste/perchlorate.

2. Disposal of used film and CCD cover

Dispose the used film covers and CCD sensor covers appropriately, according to precedures indicatated by each manufacturer and all current applicable regurations and local codes.

NOTE



BELMONT EQUIPMENT, Division of Takara Belmont, USA, Inc.

101 Belmont Drive Somerset, New Jersey 08873 U.S.A. TEL.:(732) 469-5000 / (800) 223-1192
www.belmontequip.com Fax.:(732)526-6322 / (800) 280-7504

Book No. 1A0N9RJ0

Printed in Japan 2024-08