

Belmont®

X-Calibur™ DENTAL CHAIR

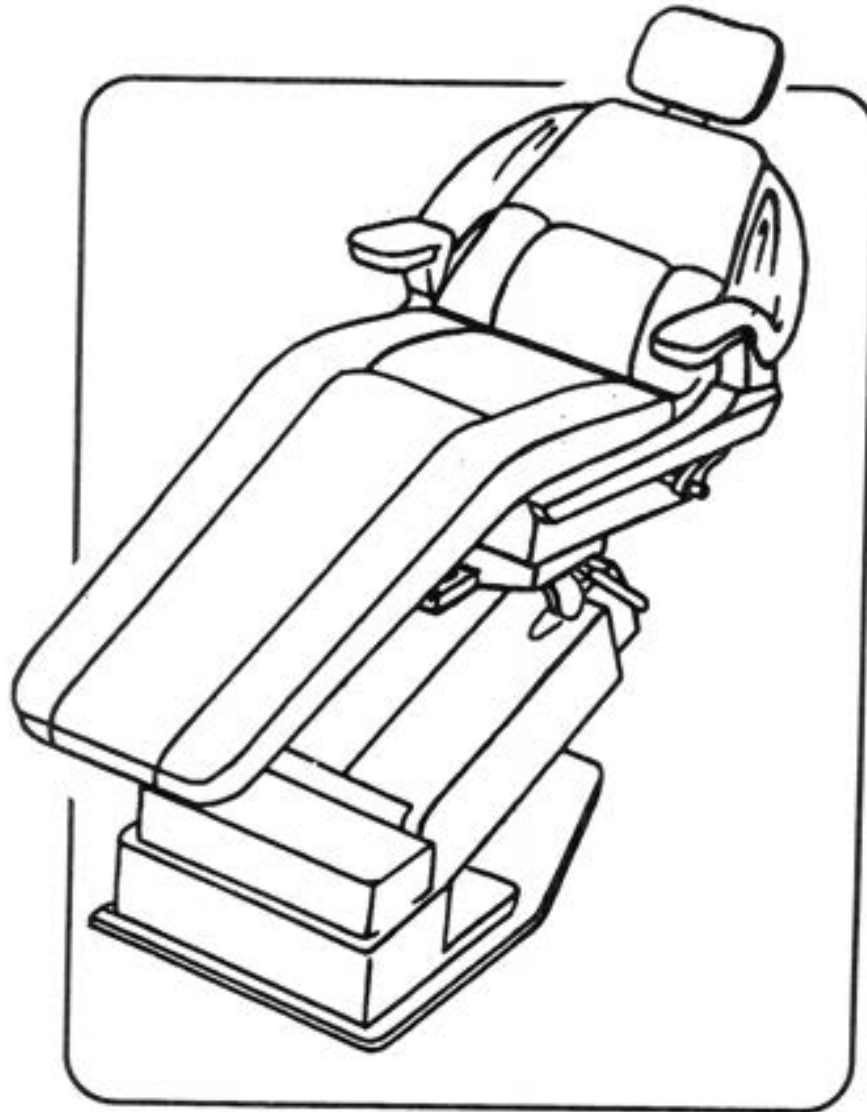

SERVICE MANUAL
BEL-10
(Bel-20)

 Belmont

BELMONT EQUIPMENT CORPORATION

101 Belmont Drive, Somerset, N.J. 08873

(908) 469-5000 Fax (800) 280-7504

Toll Free (800) 223-1192

MODELS, PRICES, AND SPECIFICATIONS ARE SUBJECT TO CHANGE WITHOUT NOTICE

***** TABLE OF CONTENTS *****

Dimensional Drawing	2
Overall View	3
Trouble Shooting	4
Base Components	5

SERVICE PROCEDURES

I. ADJUSTMENTS

1. Motion Limit Controls	6
2. Foot Control Adjustment	8
3. Rotation Lock Adjustment	8

II. HYDRAULIC AND MECHANICAL SERVICE

Hydraulic Schematic	9
Hydraulic Components	10
1. Bleeding Hydraulic System + Oil	11
2. Replenishing Hydraulic Oil	11
3. Replacing Solenoid Valve Unit	11
4. Replacing Motor Pump Assembly	12
5. Replacing Oil Reservoir	12
6. Replacing Backrest Cylinder	12
7. Replacing Base Cylinder	16

III. ELECTRICAL

1. Voltage Checks	17
2. Replacing Transformer	17
3. Replacing Relay Box	17
4. Replacing Solenoid Valve Coil	18
5. Replacement of Backrest Potentiometer	18
6. Replacement of Base Height Potentiometer	18
7. Replacement of Capacitor	19

IV. PARTS LISTS

Seat Section A Parts List	21
Seat Section A Assembly	22
Seat Section B Parts List	23
Seat Section B Assembly	24
Cantilever Arm Parts List	25
Cantilever Arm Assembly	26
Base Section Parts List	27
Base Section Assembly	28
Backrest / Headrest Parts List	29
Backrest / Headrest Assembly	30
Foot Control Parts List	31
Foot Control Assembly	32
Upholstery Parts List	33
Upholstery Assembly	34
Wiring Schematic Parts List	35
Electrical Schematic	36

DIMENSIONS (MILLIMETERS) & INCHES

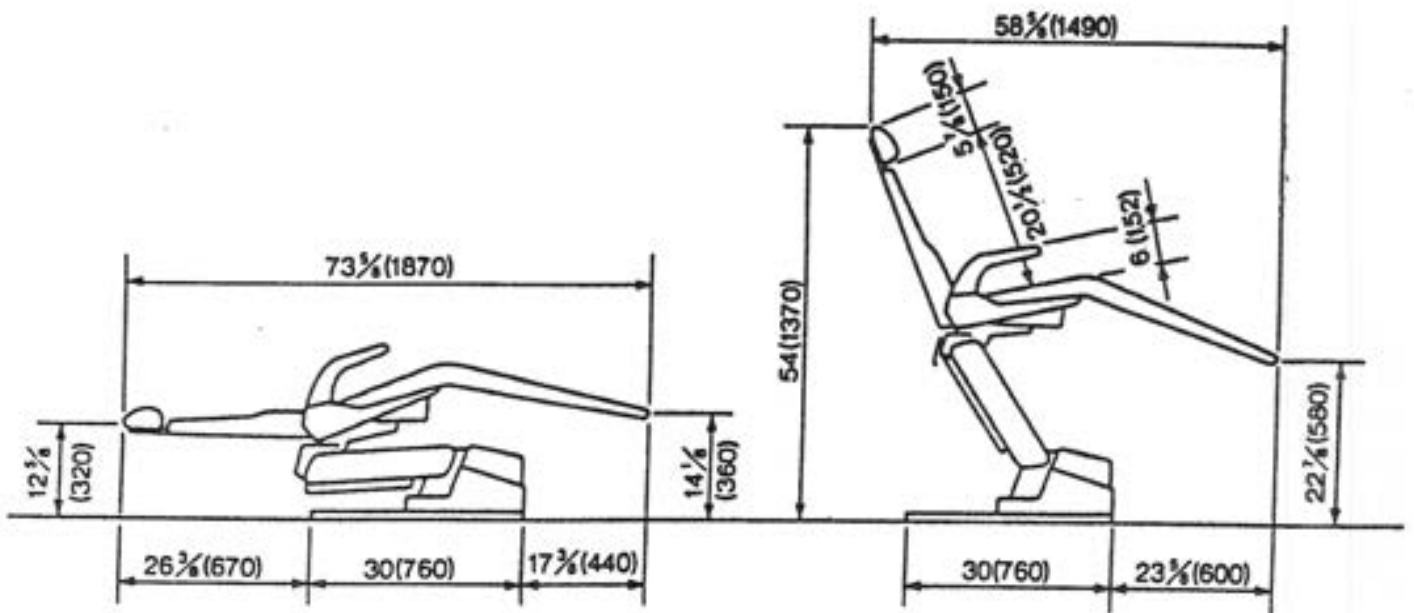
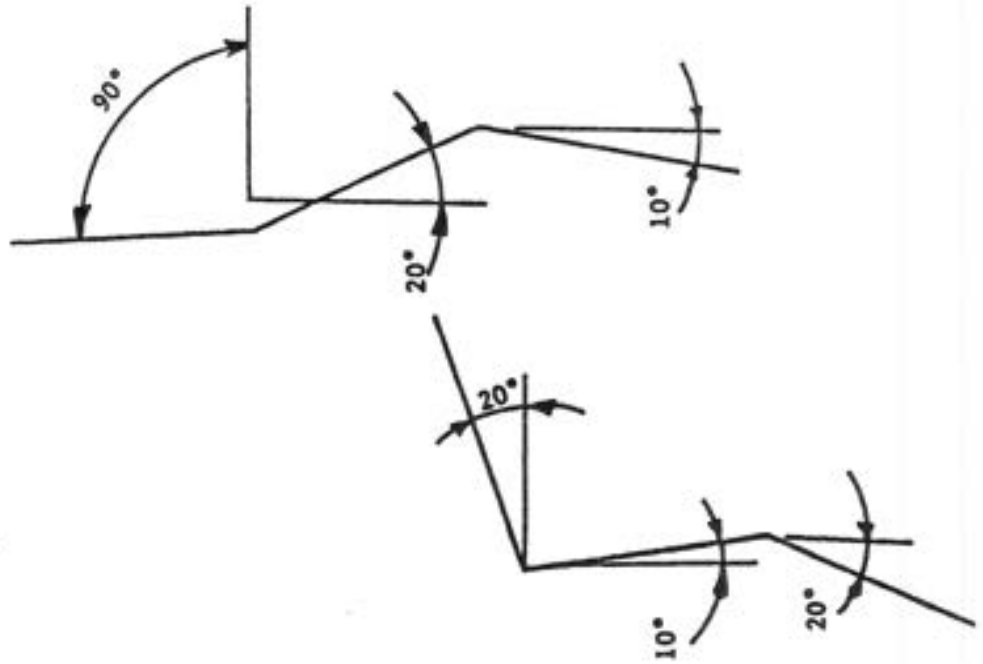
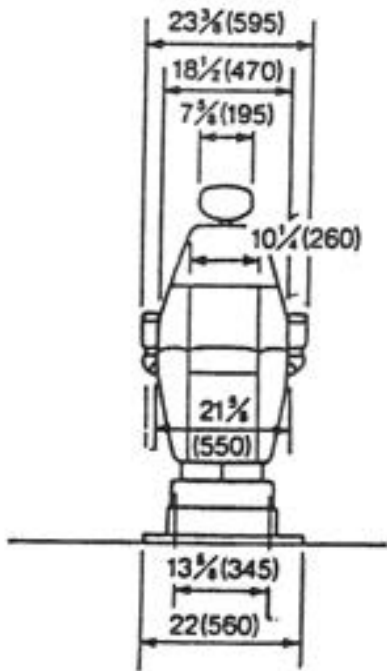

OVERALL VIEWS

FIG 3 - 1

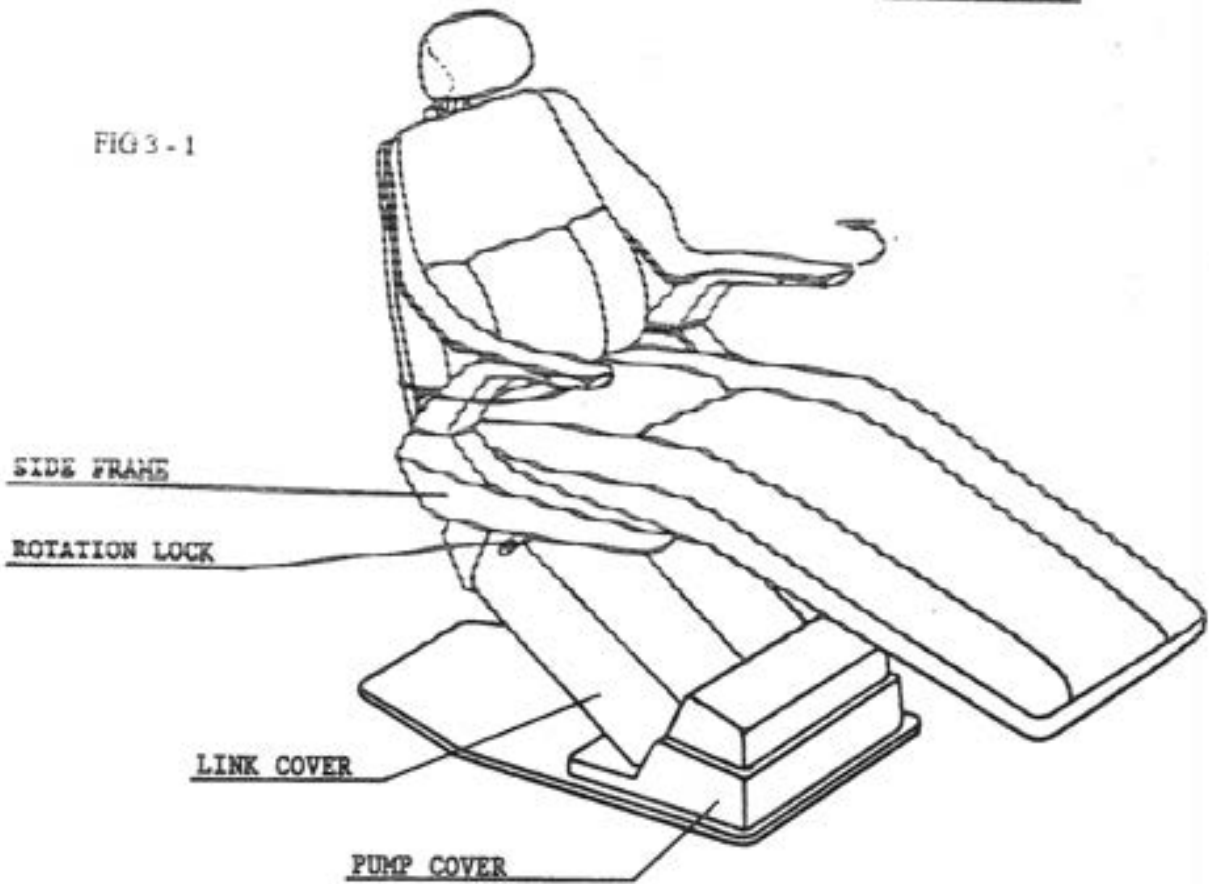
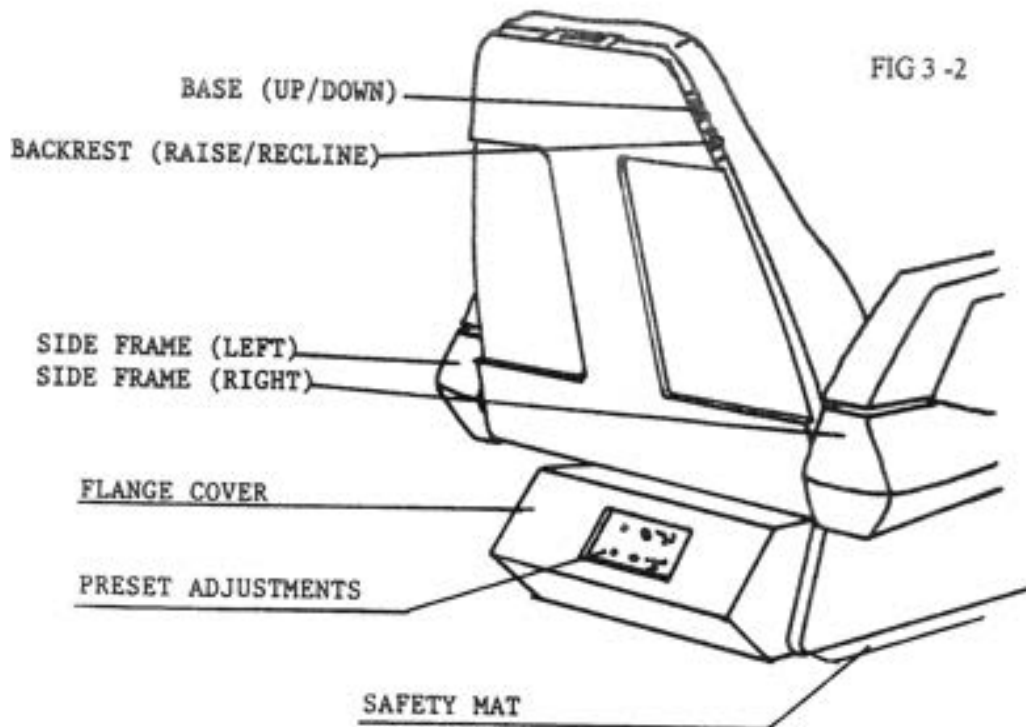

FIG 3 - 2



TROUBLE SHOOTING

PROBLEM	SOLUTION
Backrest operates but seat does not rise.	-Red shipping bolt, located in seat flange, has not been removed.
Seat or backrest goes up or down too fast or too slow.	-Adjust control (needle) valve located on fig. 3-1
Seat does not rise, backrest does not go forward, other functions work properly.	-Overheated motor. Wait 10-15 min. for thermal overload to reset. -If motor relay operates (audible click): Wiring to motor or wire connector disconnected or defective. Motor pump assembly defective. -If motor relay does not operate, Connectors (CN1 on Relay Board, S4 on Logic Board) loose or disconnected. -Transformer output problem. Proc III-1 -Relay board defective. -Logic board defective.
Chair goes up with effort, will not go up with load.	-Hydraulic system requires bleeding Proc II-1 -Oil level low. Proc II-2 -Motor capacitor defective Proc III-7 -Excessive play in gear pump. Replace the motor/pump assembly. Proc II-4
Motor continues to run after backrest forward or base up is complete.	-Limits require adjustment. Proc I-1
Switches must be pressed twice to actuate a function.	-Preset is set outside of range of limit switches. Readjust accordingly. -Base down limit not activated at end of auto-return cycle. Adjust accordingly. Proc I-1
Excessive noise in motor.	-Hydraulic system requires bleeding Proc II-1 -Low oil level. Proc II-2 -Defective motor pump. Proc II-4
Base or backrest drifts down overnight (without visible leakage)	-Leaking cylinder seals. Remove overflow line from cylinder and apply load to that function. If oil drips out, cylinder must be serviced or replaced. -Defective check valve.
Backrest switches don't work (foot control O.K.)	-Both sides: Connector between base and backrest loose, or connector S1 on logic board loose or disconnected. -One side: Connector between junction board and switch board disconnected or loose. -Defective switch.
Foot control problems, (backrest O.K.)	-All functions: Connector to chair, or connector S2 on logic board loose or disconnected -Some functions: Stops need adjustment. Proc I-2
No function of chair.	-No power--check plug, or building fuse. -Loose or disconnected connector: CN2, CN5, CN4, CN6
Chair seat will not lower (all other functions O.K.)	-Object caught under safety switch. -Connector S3 loose or disconnected. -Safety switch stuck or damaged.

FIG 3-1

CONTROL NEEDLE VALVES

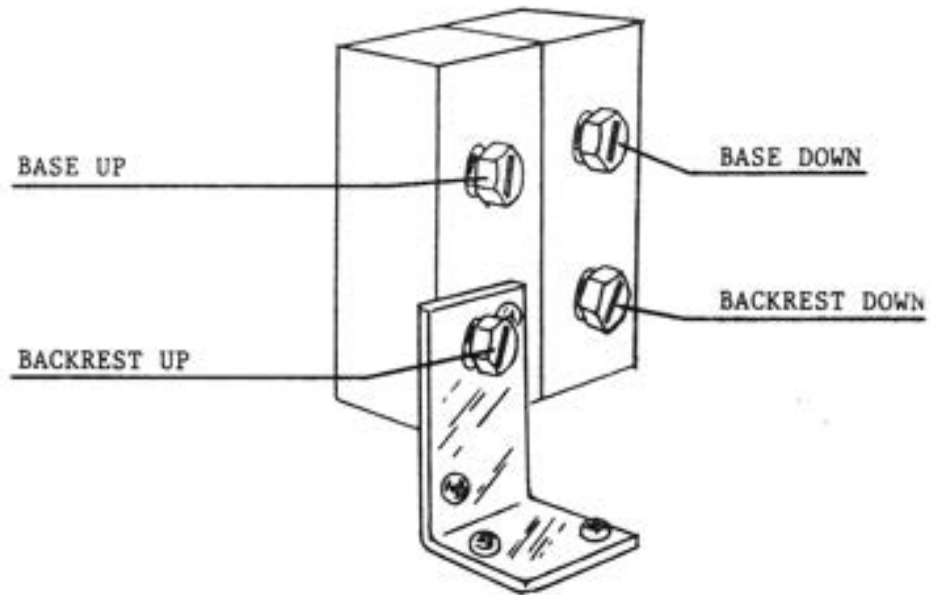

BASE COMPONENTS

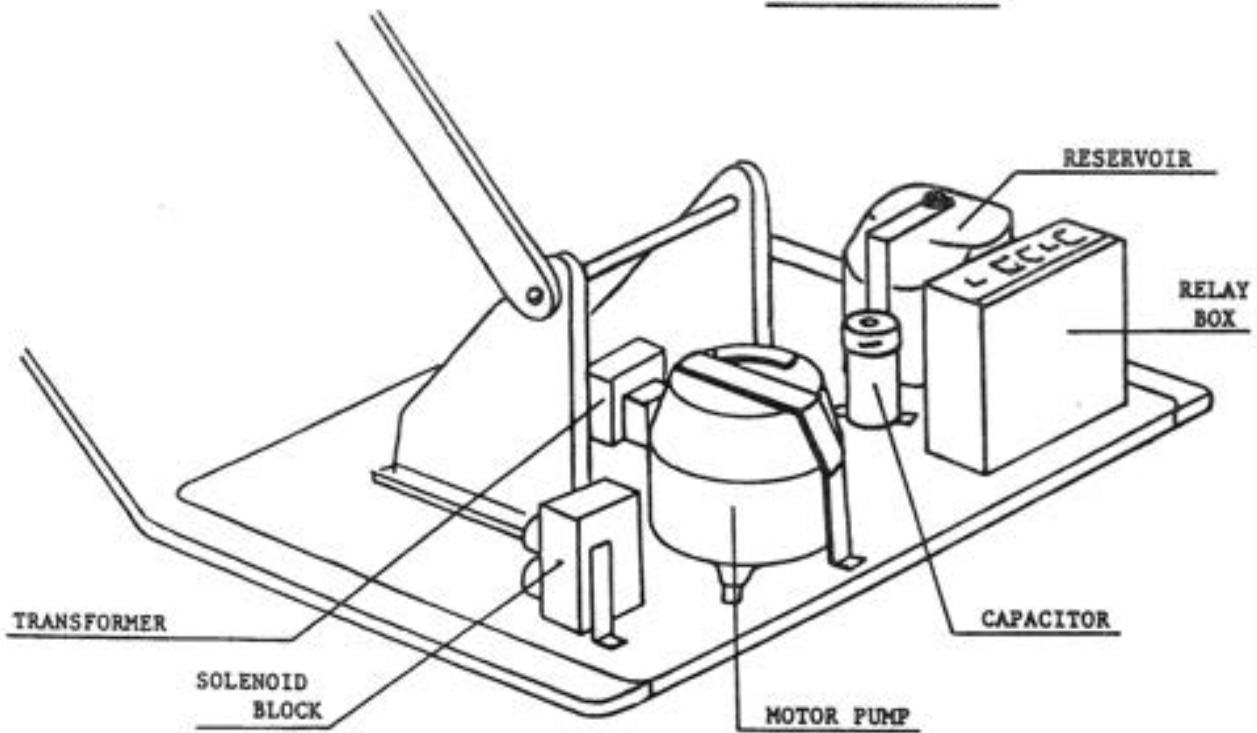

SERVICE PROCEDURES

I. ADJUSTMENTS

1 MOTION LIMIT CONTROLS

A. Function

The **X-Calibur™** dental chair does not use conventional mechanical or mercury limit switches. Motion of the chair base and backrest move variable resistances (potentiometers) making it possible for the control circuitry to continuously know the exact position of the base and backrest, not only when they hit the end of their travel. Adjustments for all four actions (base upper/lower, backrest forward/recline) are located on the logic control board.

- B. Adjustment--Follow these steps in sequence shown to obtain proper adjustment

Remove Rear Flange Cover for access to variable resistor adjusters (see fig 4-1).

FIG 4-1

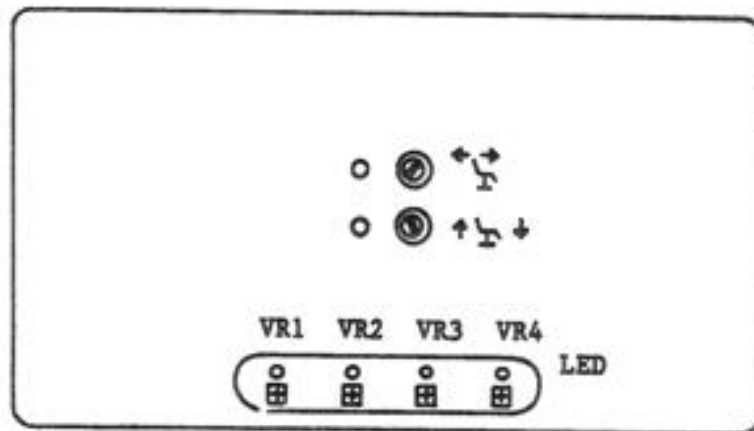

VARIABLE RESISTOR

Using the manual controls, lower the chair as far as possible. If LED #3 is not illuminated, the chair has hit its mechanical limit, otherwise turn VR (variable resistor) #3 until LED #3 goes out and lower chair further. Raise chair slightly and turn VR #3 until LED #3 just illuminates.

Raise the chair base fully. If LED #4 illuminates, turn VR #4 to allow the chair to rise further. At the physical top of travel, the motor will continue to run, but upward motion will stop (oil bypass channel has opened in cylinder). Lower the base slightly from this point, and adjust VR #4 until LED #4 just illuminates.

Lower the backrest fully. If LED #1 illuminates, turn VR #1 to allow the backrest to lower further. Raise the back slightly from this point, and adjust VR #1 until LED #1 just illuminates.

Raise the backrest fully. Remove rubber cover under left hand armrest (see fig 4-2) to expose mechanical limit screw. Loosen jam nut and turn the screw in a few turns to provide additional clearance.

FIG 4-2

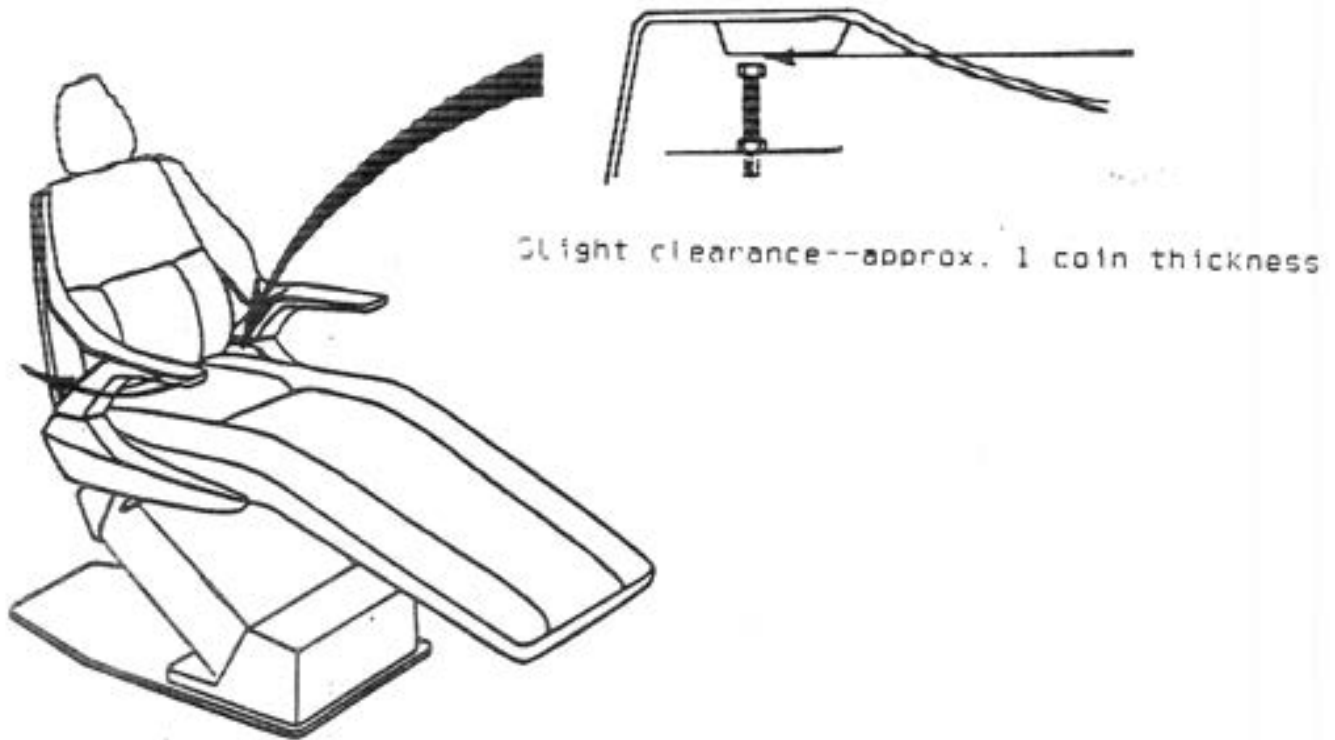

If LED #2 illuminates, turn VR #2 to allow the backrest to rise further. At the physical top of travel, the motor will continue to run, but upward motion will stop (oil bypass channel has opened in cylinder).

Back out the mechanical limit screw until it almost contacts underside of side casting (about 1 coin thickness). Retighten jam nut. This adjustment is CRITICAL to prevent damage to the chair if the backrest is pushed forward by hand beyond cylinder travel.

Lower the backrest slightly from this point (about 70 degree angle), and adjust VR #2 until LED #2 just illuminates.

2 FOOT CONTROL ADJUSTMENT AND SERVICE

A Adjustment

- 1 The 4 stop screws serve to allow the foot disc assembly to activate the internal switches without placing excess pressure.
- 2 Back off the stop screws a few turns and activate the foot disc by hand into each of the 4 positions. Bring up the appropriate stop screws to stop the travel at precisely that point, then tighten jam nut.
- 3 After tightening all 4 jam nuts, confirm operation in each direction.

B Disassembly

- 1 With 2mm hex key, loosen 3 set screws around circumference of foot disc and pull off disc.
- 2 Remove the 4 screws at the four corners of the underside and remove the bottom plate assembly.

3 ADJUSTMENT OF ROTATION LOCK

A Remove seat cushion, and while observing the clamping mechanism, rotate the chair slightly to determine if the mechanism itself is loose. If loose, tighten the shaft mounting plate located under seat flange. (see fig 4-3)

B To adjust the clamping mechanism: (see fig 4-4)

- 1 Set lock bar into unlocked position.
- 2 Loosen hex nut (using 21mm wrench -- LEFT HAND THREAD).
- 3 Tighten socket cap screw firmly (using 6mm hex key), then back off 1/8 to 1/4 turn.
- 4 Keeping socket cap screw from turning, retighten hex nut (LEFT HAND THREAD).

FIG 4 - 3

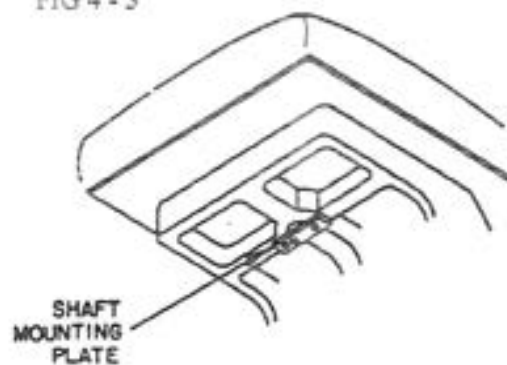
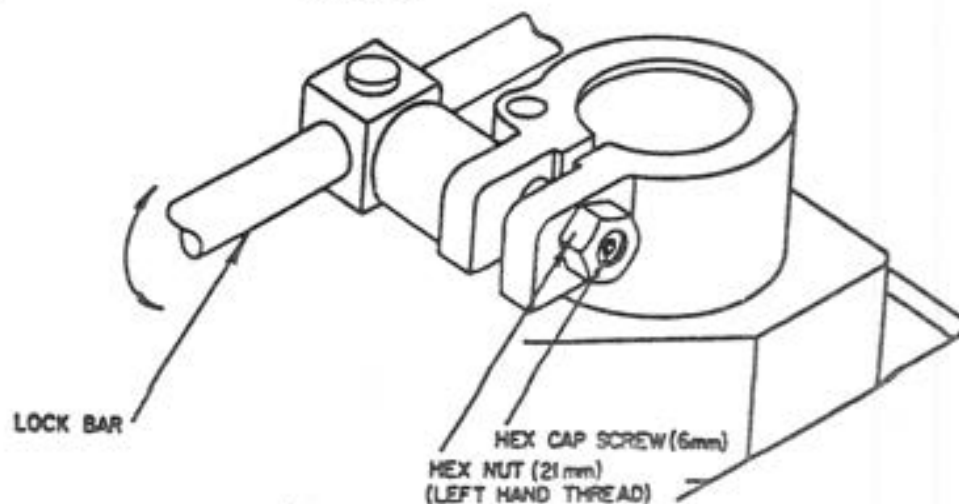
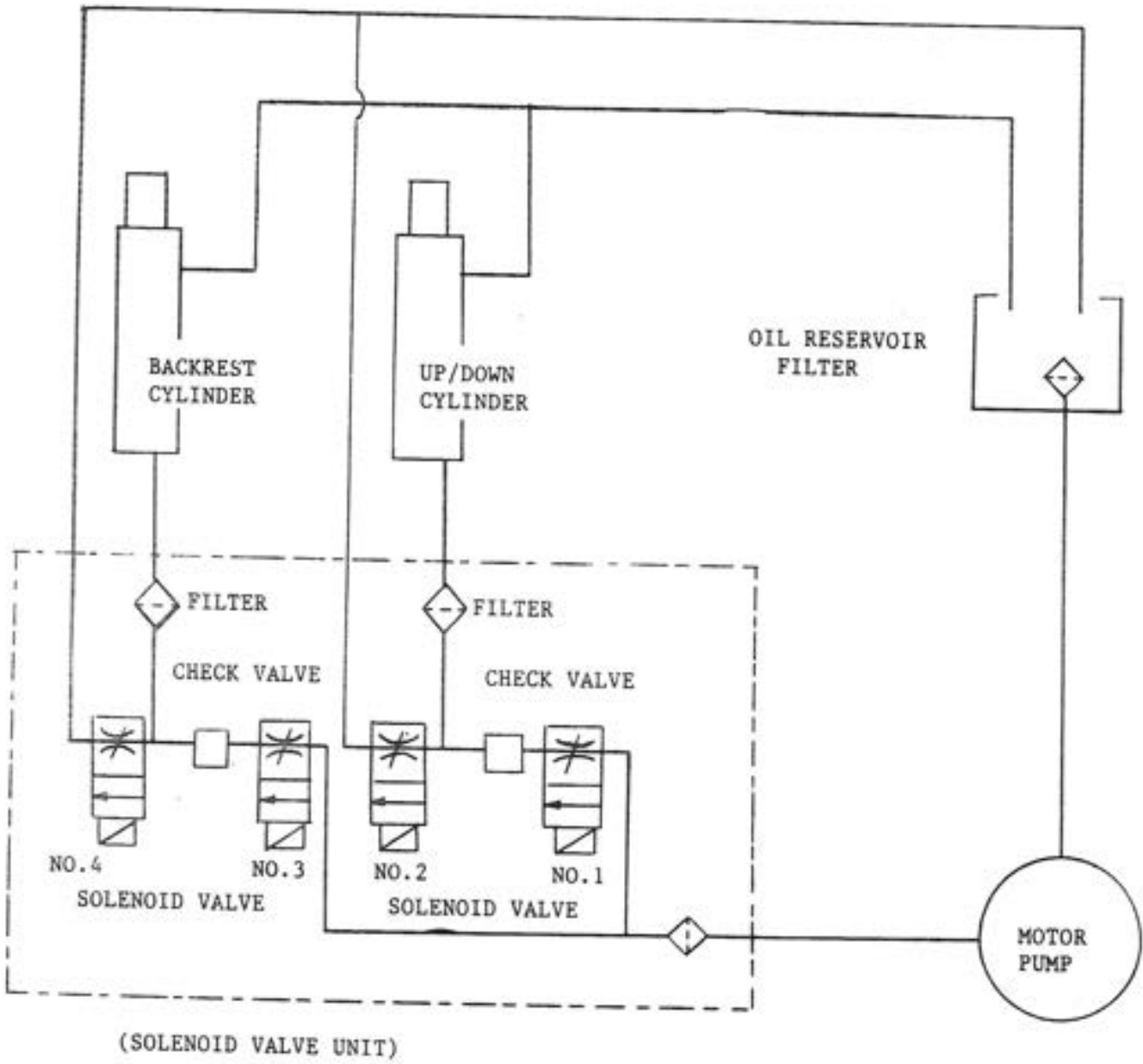

FIG 4 - 4



HYDRAULIC SCHEMATIC



Hydraulic Components.

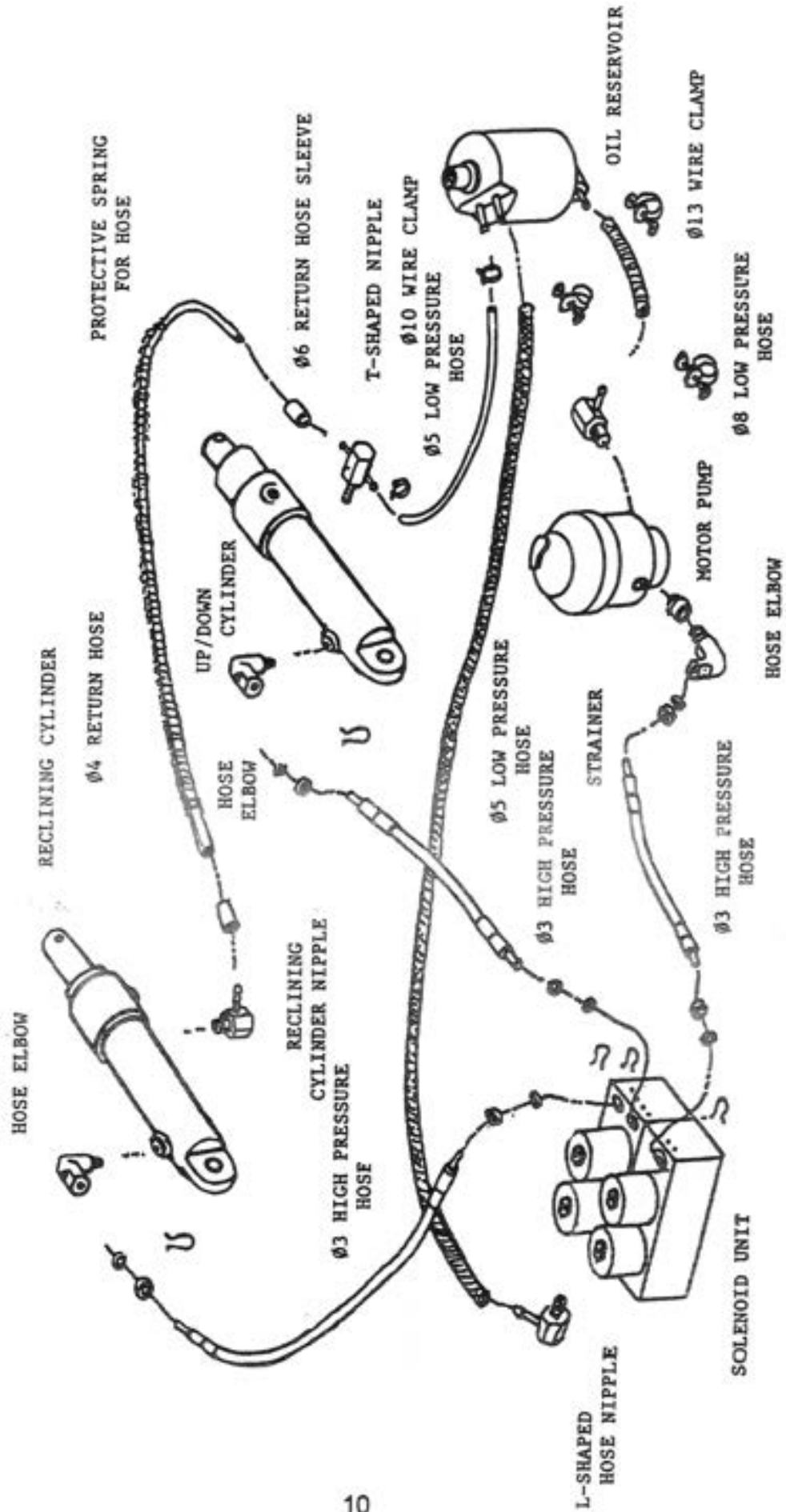

II. HYDRAULIC & MECHANICAL SERVICE

1 BLEEDING THE HYDRAULIC SYSTEM

Air trapped in hydraulic system can cause excessive noise and erratic performance. To purge system of air, proceed as follows. The **X-Calibur™** chair is a closed system and does not require bleed valves as such.

- A. Raise base to maximum height and seatback fully forward. Confirm that there is still about 1" of oil in the reservoir. Add oil if necessary.
- B. Run through about 10 cycles of lowering and raising both chair and backrest while someone is seated in the chair.

2 REPLENISHING HYDRAULIC OIL

- A. The **X-Calibur™** hydraulic system requires approximately 17 oz. of hydraulic oil. For a rough inspection, raise the chair base to the top position and bring backrest upright. The oil level should be approximately one inch deep in the oil reservoir.
- B. If hydraulic oil is required, remove breather from top of reservoir neck and pour oil through filter hole.
- C. Replace breather.

3 REPLACING THE SOLENOID VALVE UNIT (see fig 4-5)

FIG 4-5

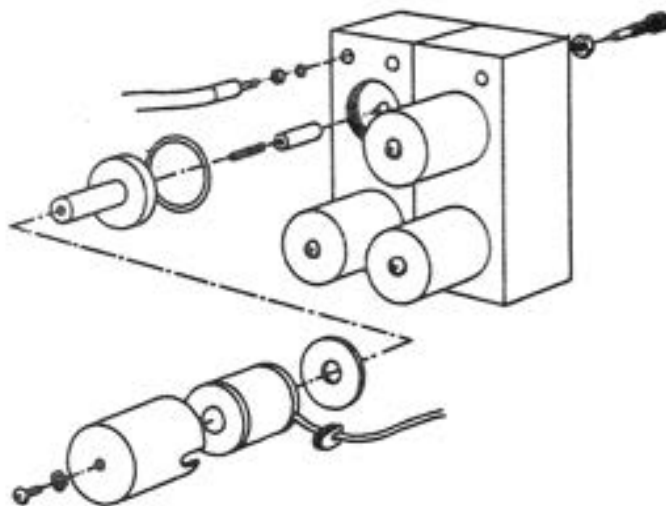

PROTECT FLOOR FROM POSSIBLE OIL SPILLAGE

- A. Raise chair.
- B. Brace chair seat securely to prevent travel when hoses are removed.
- C. UNPLUG CHAIR POWER SUPPLY.
- D. Disconnect the 9 pin connector (CN4) at the relay box.
- E. LABEL ALL HOSE CONNECTIONS prior to disassembly for identification when reassembling.
- F. Extract U-pins which secure high pressure hoses and pull out. (see Proc II-8).
- G. Unscrew Phillips screws securing solenoid mounting brackets to chair base and remove solenoid valve unit.

II. HYDRAULIC & MECHANICAL (CONTINUED)

4 REPLACING MOTOR PUMP ASSEMBLY

PROTECT FLOOR FROM POSSIBLE OIL SPILLAGE

- A. Raise chair base to highest position. UNPLUG POWER SUPPLY.
- B. Remove 1 M6 phillips screw securing front portion of motor clamp to base. bend clamp out of the way.
- C. Disconnect power supply to motor connector CN3 at relay box.
- D. Lift motor to full height allowed by interconnecting hoses.
- E. Loosen 10mm wire clamp and disconnect low pressure hose. NOTE: Secure hose end higher than reservoir to avoid spillage.
- F. Extract U-pin from mini-hose connector and disconnect high pressure hose (see Proc II-8).
- G. Remove brass fittings from motor pump for re-use.
- H. After replacement, inspect hydraulic system to insure there is sufficient oil and bleed system if necessary (see Proc II-1.2).

5 REPLACING OIL RESERVOIR

PROTECT FLOOR FROM POSSIBLE OIL SPILLAGE

- A. Raise chair base to highest position and raise backrest to full upright position. UNPLUG POWER SUPPLY.
- B. Remove hex nut securing reservoir to mounting bracket.
- C. Remove M8 Phillips screw securing mounting bracket to chairbase. Position bracket onto replacement reservoir and secure with nut.
- D. Angling reservoir so oil is away from 10mm hose. remove hose and secure to replacement reservoir.
- E. Using a small thin screwdriver, remove breather from replacement reservoir and drain remaining oil from old reservoir into replacement. Replce breather.
- F. Remove 2.5mm hoses from old reservoir and secure to replacement.
- G. Secure reservoir mounting bracket to chair base.
- H. After replacement, inspect hydraulic system to insure there is sufficient oil and bleed system if necessary (see Proc II-1.2).

6 - 1. REPLACING BACKREST CYLINDER

SEE PG. 13 (TOP)

Determine if chair has a black upholstered back or a white plastic backrest and follow the procedures below for that chair.

A - 1. **Black Back**

Remove headrest from chair.

Remove back upholstery by unsnapping (2) upper snaps and pulling back upholstery down and away from velcro strips.

A - 2. **White Back**

Remove headrest from chair.

Remove (2) sheet metal screws from top of back frame, (2) small pan head screws from around switch assembly and (2) pan head screws from the bottom of back cover.

Unsnap back upholstery from chair.

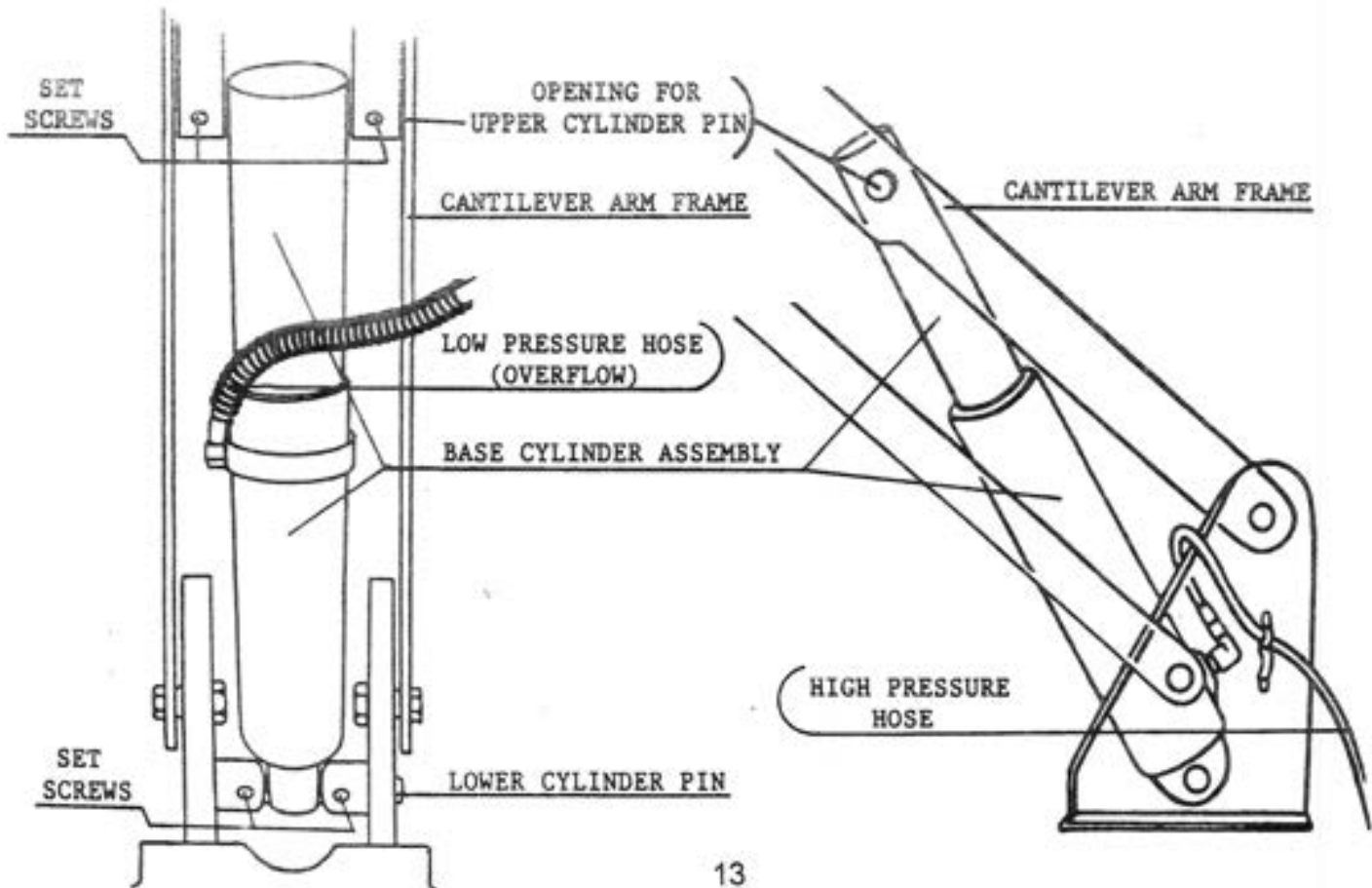
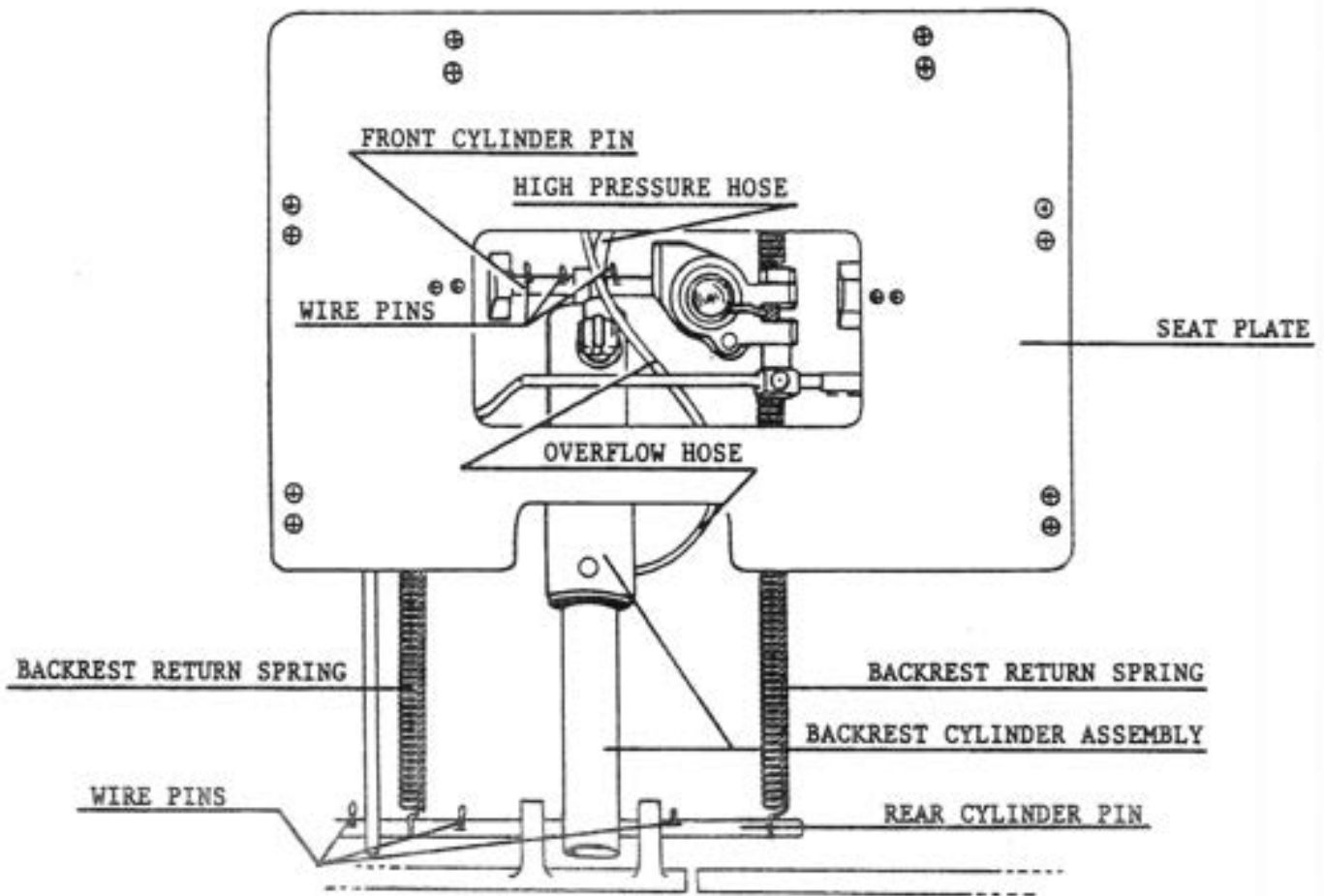

- B. Remove seat upholstery by unsnapping the upholstery from the metal frame, remove the (4) pan head screws securing frame to chair, then set entire assembly aside.
- C. Lower backrest all the way down.
- D. unplug chair.
- E. Pull out the (3) wire pins from the rear cylinder pin that attaches the backrest to the piston.
- F. Remove potentiometer recline link from the rear cylinder pin and let it drop down and rest on pump back cover.
- G. Remove (4) pan head screws from side cover that goes around seat plate assembly and remove side cover.
- H. Unhook the (2) backrest return springs from the bar at each side of the piston and remove.
- I. Pull out the (3) wire pins that secure the rear cylinder pin.
- J. Remove wire connector from chair back, remove (4) bolts securing backrest to chair and remove back.

CAUTION!

WHEN REMOVING THE PISTON, THERE IS A CHANCE OF OIL SPILLAGE.
PROTECT THE FLOOR!

- K. Pull out the u-clip holding the pressure hose into the piston.
(To prevent the hose from leaking upon re-assembly, be sure the brass spacer goes on the hose first, then the black o-ring. See pg 16 / fig. 4-6)
- L. Remove rear cylinder pin.
- M. Remove front cylinder pin.
- N. Remove back piston.

6 - 2. RE-ASSEMBLY PROCEDURE

- A. Place new piston in position and install front cylinder pin with the (3) wire clips.
- B. Install rear cylinder pin through backrest bracket and position and center.
- C. Install brass spacer on high pressure hose, then black O-ring. Push hose into piston and install u-clip. (Be sure clip seats all the way down or leakage will occur.)
- D. Install the backrest using (4) bolts and connect the wire connector to the chair back.
- E. Install the (2) backrest springs. (Make sure the springs are seated in the grooves on the rear cylinder pin.)
- F. Replace the potentiometer recline link.
- G. Replace the (3) wire clips in the rear cylinder pin.
- H. Install the seat frame with the (4) pan head screws.
- I. Snap seat upholstery onto seat frame.
- J - 1. **White Back**
Snap back upholstery onto seat back frame. Tuck the seat flap under the seat cushion. Install white plastic back using the (6) screws taken out in step A - 2.
Install the headrest.
- J - 2. **Black Back**
Snap the (2) upper snaps to the back then push the back upholstery down against the velcro strips. Tuck the seat flap under the seat cushion. Install the headrest.

- K. Plug in the chair and run through complete back cycle. Check for leakage around the high pressure hose.
- L. Remove the (5) screws securing the pump cover to the base of the chair and remove the cover.
- M. Raise the base to the full height and raise the backrest to the full upright position.
- N. The fluid in the hydraulic revision should be approximately 1" deep. If not, remove the breather from the top of the revision and add oil. Replace the breather. (See pg 5 / Fig. 3-2)
- O. Replace the pump cover.
- P. If the chair back is noisy or spongy, put some weight on the back of the chair and run the back through 8 or 9 cycles to purge the system of air.

TOOLS REQUIRED

- (1) Needle nose pliers
- (2) Standard pliers
- (3) Awl
- (4) Rags
- (5) Ball - peen hammer
- (6) Standard and Phillips screw drivers
- (7) Bel-10 Service Manual
- (8) Vise - grips

II. HYDRAULIC & MECHANICAL (CONTINUED)

7 REPLACING BASE CYLINDER See pg. 13 (BOTTOM)

PROTECT FLOOR FROM POSSIBLE OIL SPILLAGE

- A Raise chair fully and remove plastic covers from cantilever arm, pump assembly (on base) and flange cover (by preset control panel).
- B Provide SECURE support under seat structure. A 2x4 piece of lumber, 16-1/2" long will fit under the flange casting when chair is fully up.

WARNING: Be careful not to dislodge this support while working on the cylinder.

- C Remove the 4 mounting screws and remove the safety switch mechanism as a unit.
 - D Loosen the 4 set screws holding the upper and lower cylinder pins (smm hex key) and drive the upper pin to one side (openings are provided in the cantilever arm frame).
 - E Remove the low pressure (overflow) hose from the top of the cylinder and the high pressure hose from near the bottom (see Proc II-8).
 - F Drive the lower cylinder pin out to one side.
 - G Remove cylinder.
 - H After replacement, inspect hydraulic system to insure there is sufficient oil and bleed system if necessary (see Proc II-1.2).
- ### 8 HIGH PRESSURE HOSE FITTINGS

NOTE: The high pressure hose fittings used in the X-Calibur™ chair are designed for quick release/connection and easy service. To disconnect, pull out the wire U-clip and separate the hose.

The O-ring and brass retainer ring are located in the fitting body but may sometimes drop out when the hose is removed. Be sure that these are in place before replacing hose or the connection will leak.

When assembling these connections, be sure the parts are assembled as in fig. 4-6.

FIG 4-6

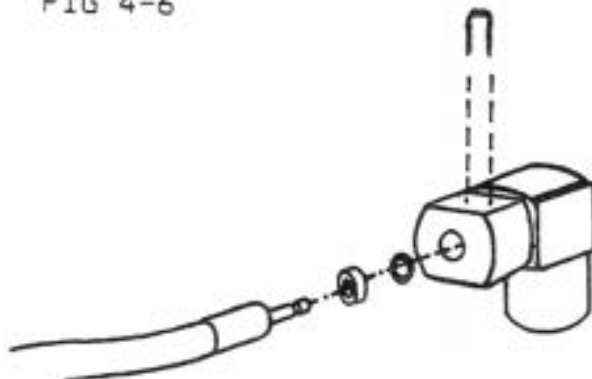

III. ELECTRICAL

1 VOLTAGE CHECKS (see fig 4-7)

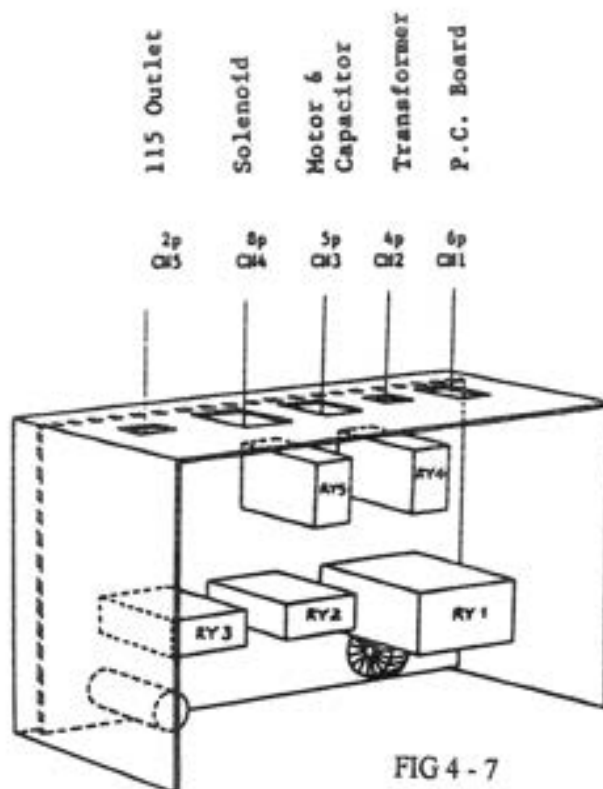

FIG 4-7

- A. INCOMING LINE VOLTAGE CHECK TO RELAY BOX. Remove 2-wire connector CN5. Using an AC voltmeter, measure incoming voltage from this line. (should be 110-115 VAC).
- B. HIGH VOLTAGE CHECK RELAY BOX TO TRANSFORMER. Using an AC voltmeter, check voltage between pins 1&2 of CN2. (should be 110-115 VAC).
- C. LOW VOLTAGE CHECK FROM TRANSFORMER TO RELAY BOX. Disconnect CN2 and insert jumper wires from terminals #1 & #2 of both halves to supply power to the transformer. Using an AC voltmeter, check low voltage across terminals #3 & #4 (should be 12-14 VAC) and also terminals 1 & 2 of the separate connector CN6 (should be 14-16 VAC).

2 REPLACING THE TRANSFORMER

- A. UNPLUG CHAIR POWER SUPPLY
- B. Disconnect 2-wire connector (CN6) at transformer and 4-wire connector (CN2) at relay box.
- C. Unscrew 2 M4 Phillips screws securing transformer to chair base. Lift transformer from base assembly.

3 REPLACING RELAY BOX

- A. UNPLUG CHAIR POWER SUPPLY
- B. Disconnect the 5 connectors connecting the relay box into the chair circuitry.
- C. Unscrew 2 M5 Phillips screws securing the relay box onto the chair base. Lift relay box from base assembly.

4 REPLACING A SOLENOID VALVE COIL

- A. Unscrew hex head screw securing solenoid cap to stem and remove cap, coil, and coil retaining washer. see fig 4-5.
- B. To replace the coil: Remove the coil from the cap, cut the two power leads. Splice the power leads onto the leads just cut from the relay box connector (CN4).

5 REPLACEMENT OF BACKREST POSITIONING POTENTIOMETER (RHEOSTAT)

- A. Remove side cover from around seat plate assembly.
- B. Raise chair base and recline backrest. Remove connecting links and unsolder connections from potentiometer.

NOTE: If the backrest cannot be lowered because of damage to the old potentiometer, proceed as follows:

1. Temporarily connect the wires to the new potentiometer (see fig 4-8).

FIG 4-8

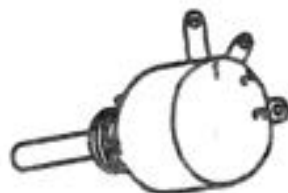

- #1—Red wire
- #2—Orange wire
- #3—Brown wire

2. Turn shaft fully counter clockwise.
 3. Plug in chair and recline backrest to Limit. Remove wires from potentiometer and unplug chair.
- C. Remove old potentiometer from bracket.
 - D. Using a volt-ohmmeter, adjust shaft for a reading of .5-.6 K ohm between terminals 2 and 3.
 - E. Keeping that position, insert the potentiometer into the bracket, making sure alignment pin fits into hole in bracket. Tighten nut without rotating shaft.
 - F. After installation, it is necessary to reset backrest Limit settings (see Proc I-I).

6 REPLACEMENT OF THE BASE HEIGHT POTENTIOMETER (RHEOSTAT)

NOTE: If component failure has left chair in the base down position, it will be necessary to lift chair by hand before removing pump cover housing.

- A. Remove pump cover housing.
- B. Raise the chair to its highest position. If the chair seat cannot be raised because of damage to the old potentiometer, proceed as follows:
 1. Temporarily connect the wires to the new potentiometer (see fig 4-8).
 2. Turn shaft fully clockwise.
 3. Plug in chair and raise the seat as far as it will go. Remove wires from potentiometer and unplug chair.
- C. Remove the two screws retaining the backrest and loosen the set screw (2mm hex key) in the base link pin which retains the potentiometer shaft. Remove this assembly.
- D. Insert the potentiometer into the bracket making sure alignment pin fits into hole in bracket. Carefully tighten nut.
- E. Using a volt-ohmmeter, adjust shaft for a reading of about 3K ohm between terminals 2 and 3.

- F. Keeping the shaft in position, carefully insert shaft into engagement hole in base link pin. With the bracket situated so that the mounting screws fit in about the middle of the adjustment slot, tighten the set screw and the bracket screws. (see fig 4-9).
- G. After installation, it is necessary to reset seat height limit settings (see Proc I-2).

7 REPLACEMENT OF CAPACITOR

NOTE: Actual capacitor is contained inside metal canister. Remove canister and slide connectors off, do not cut wires. (see fig 4-10)

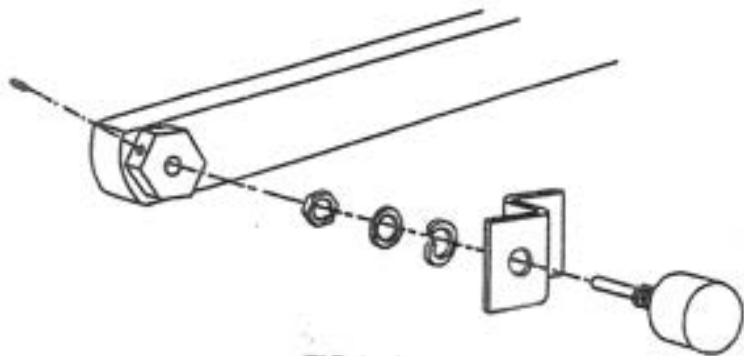

FIG 4 - 9

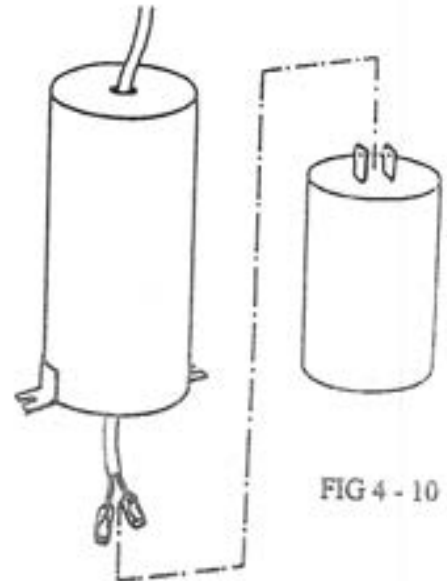
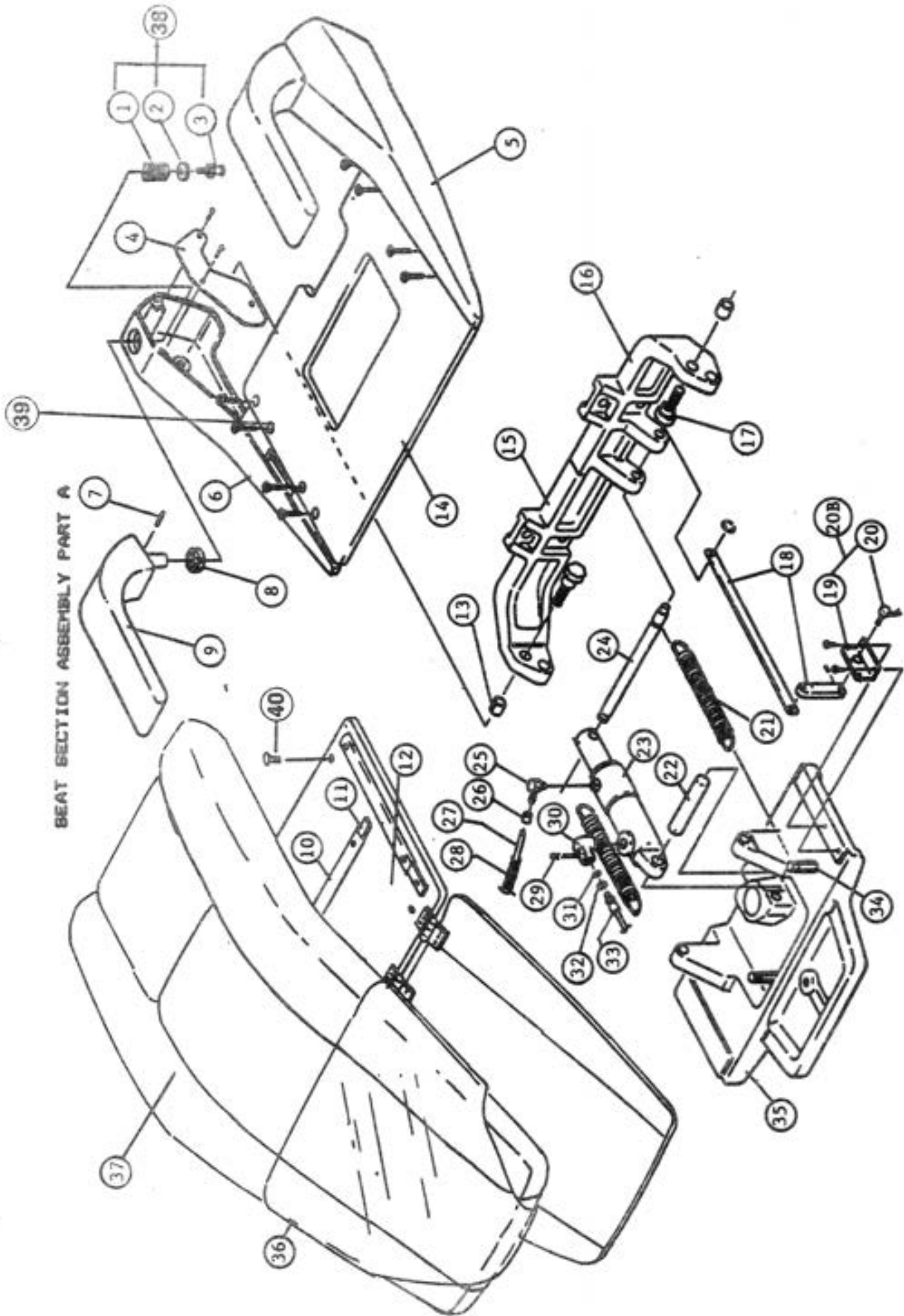

FIG 4 - 10

SEAT SECTION ASSEMBLY PART A

INDEX NO.	PART NO.	DESCRIPTION	QTY
1-3	B10-Q3506	ARMREST SPRING, WASHER, SCREW	2
1	B10-Q3505	ARMREST SPRING	2
2	B10-Q3503	ARMREST WASHER	2
3	B10-U3919	MISC. SCREW (ARMREST)	2
4	B10-J3684	RUBBER SIDE COVER	2
5	B10-L3608	SIDE FRAME LEFT	1
6	B10-L3607	SIDE FRAME RIGHT	1
7	B10-Q3586	ARMREST PIN	2
8	B10-G0048	ARMREST CAM (180 DEGREES)	2
9	B10-M3532B	ARMREST ASS*Y W/PIN (BLACK)	2
	B10-M3532G	ARMREST ASS*Y W/PIN (GREY)	2
10	B10-X6795	VELCRO STRIP	1
11	B10-J3685	VELCRO PLATE (LONG)	1
12	B10-503907B	SEAT PLATE ASSEMBLY (BLACK)	1
	B10-503907W	SEAT PLATE ASSEMBLY (WHITE)	1
13	B10-X2707	BUSHING	2
14	B10-H3824	SEAT PLATE	1
15	B10-K3873	BACK SUPPORT (RIGHT)	1
16	B10-K3874	BACK SUPPORT (LEFT)	1
17	B10-U3533	TAPERED BOLT	2
18	B10-503906	RECLINE LINK COMPLETE	1
19	B10-J3682	POTENTIOMETER BRACKET	1
20	B10-503730	POTENTIOMETER	1
20B	B10-503904	RECLINE POTENTIOMETER ASSEMBLY	1
21	B10-T3692	SPRING	2
22	B10-U3526	CYLINDER PIN (FRONT)	1
23	B10-503721	RECLINE CYLINDER COMPLETE	1
	B10-599000	O-RING KIT FOR RECLINE CYLINDER	1
24	B10-T3965	CYLINDER PIN (REAR)	1
25	B10-Q3300	ELBOW	1
26	B10-X5514	CLAMPING SLEEVE	1
27	B10-X5513	RETURN HOSE	1
28	B10-Q9917	PROTECTIVE SPRING	1
29	B10-Q6237	U-CLIP	1
30	B10-T1027	ELBOW	1
31	B10-F3470	O-RING	1
32	B10-Q6241	BRASS RING	1
33	B10-U5035	HIGH PRESSURE HOSE (1400 mm)	1
34	B10-U3524	SPRING STUD	2
35	B10-H3728	ROTATION FLANGE	1
36	SEE PG. 13	LEGREST PROTECTOR FOR BEL-10	1
37	SEE PG. 13	SEAT CUHSION FOR BEL-10	1
38	B10-503911	HARDWARE KIT	2
39	N/N	SCREW (M7 x 18 mm)	8
40	N/N	SCREW (M5.5 x 14 mm)	4



SEAT SECTION ASSEMBLY PART B

INDEX NO.	PART NO.	DESCRIPTION	QTY
1	B10-H3824	SEAT PLATE	1
2	B10-M3581	FOOTREST SUPPORT BAR	1
3	B10-J3680	LINK ANCHOR (RIGHT)	1
4	B10-G0050	GRIP	2
5	B10-K3873	BACKREST SUPPORT (RIGHT)	1
6	B10-T3976	ATTACHMENT PLATE	1
7	B10-K3874	BACKREST SUPPORT (LEFT)	1
8	B10-T3964	RECLINE LINK	2
9	B10-R1186	LINK PIN	4
10	B10-J3681	LINK ANCHOR (LEFT)	1
11	B10-K3496	ROTATION LEVER	1
12	B10-U3539	NUT	1
13	B10-F6104	LOCK SHAFT	1
14	B10-U3521	ROTATION SHAFT	1
15	B10-E6017	CLAMPING BODY (LOCK)	1
16	B10-U2102	LEFT HAND NUT	1
17	B10-Q3113	WIRE CLIP	2
18	B10-U3524	SPRING STUD	2
19	B10-U3525	TILT PIN	2
20	B10-L3606	FLANGE COVER (WHITE)	1
21	B10-M3961	CIRCUIT BOARD COVER (WHITE)	1
22	B10-X6519	LOGIC P.C. BOARD	1
23	B10-B3846	FLANGE	1
24	B10-U3522	SHAFT FIXING PLATE	1
25	B10-U3809	CLIP	1
26	B10-H3728	DOME CASTING	1
27	B10-M3962	SIDE COVER (WHITE)	1
28	B10-X5779	LOCK KNOB	1
29	B10-U3531	UNIT SWIVEL PIN (OPTIONAL)	1
30	N/N	SCREW (M7 x 18 mm)	4
31	N/N	SCREW (M7 x 24 mm)	4
32	N/N	SCREW (M7 x 10 mm)	4

SEAT SECTION ASSEMBLY PART B

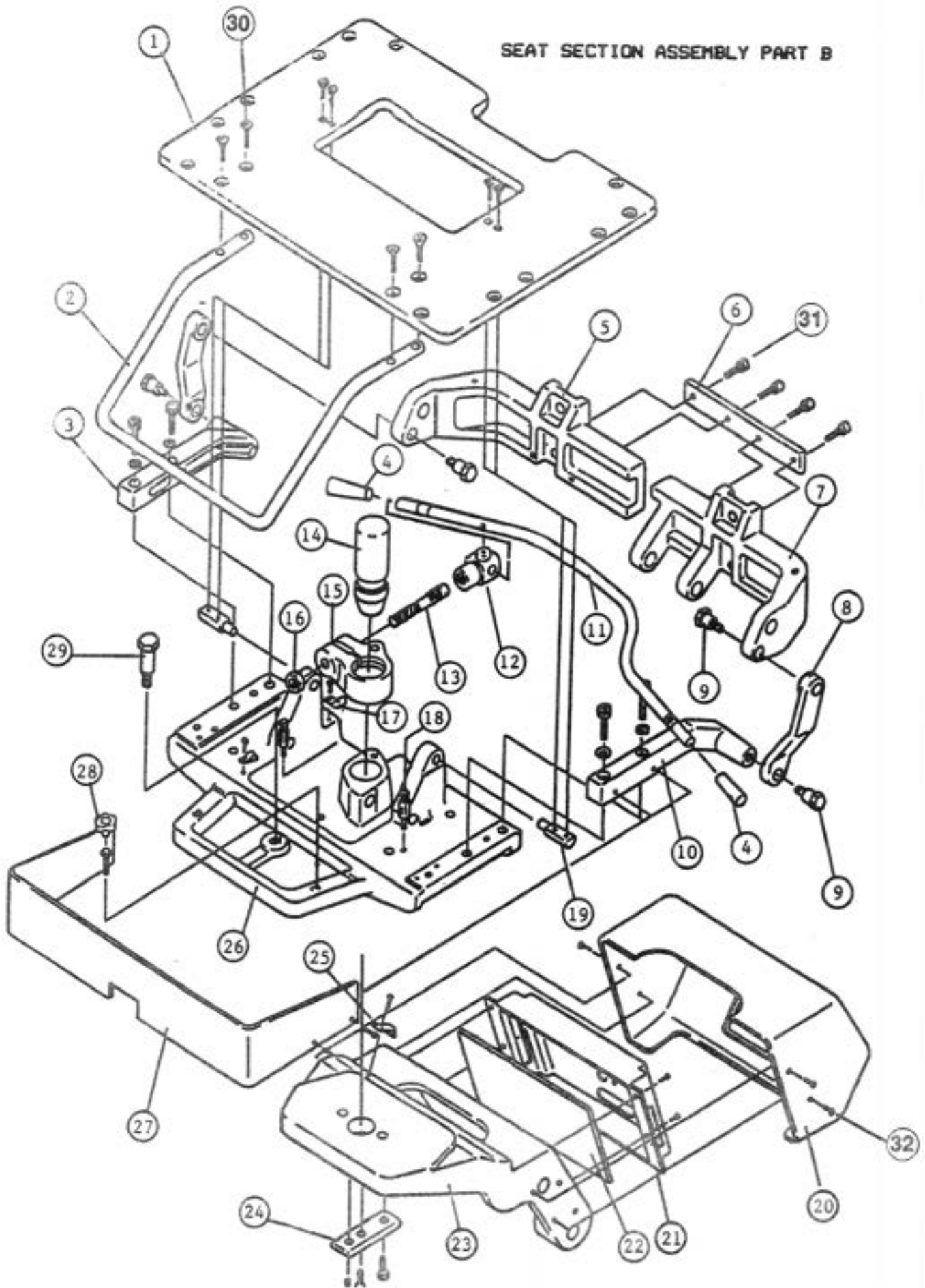

CANTILEVER ARM ASSEMBLY

INDEX NO.	PART NO.	DESCRIPTION	QTY
1	B10-H3076	PUMP COVER (WHITE)	1
2	B10-H3077	LINK COVER RIGHT (WHITE)	1
3	B10-K3495	PUMP COVER REAR (WHITE)	1
4	B10-X0285	SHIPPING BOLT	1
5	B10-B3452	MAIN LINK	1
6	B10-B3846	FLANGE	1
7	B10-X6340	BUSHING	1
8	B10-P3441	LINK PIN (UPPER)	8
9	B10-H3078	LINK COVER LEFT (WHITE)	2
10	B10-503908B	SAFETY PLATE W/BUMPER (BLACK)	1
	B10-503908W	SAFETY PLATE W/O BUMPER (WHITE)	1
11	B10-X6313	SWITCH	1
12	B10-T3427	SWITCH BRACKET	1
13	B10-T3426	SAFETY PLATE SUPPORT FRAME	1
14	B10-A3099B	BASE MAT (RUBBER) BLACK	1
	B10-A3099G	BASE MAT (RUBBER) GREY	1
15	B10-A3098	BASE PLATE	1
16	B10-503905	POTENTIOMETER W/WIRE & BRACKET F/BASE	1
17	B10-U3330	POTENTIOMETER BRACKET	1
18	B10-T3429	SUB LINK (LEFT)	1
19	B10-X4321	BUSHING	1
20	B10-U3331	SUB LINK SHAFT (LEFT)	1
21	B10-R3461	PUMP COVER BRACKET	1
22	B10-K3182	BASE LINK (LEFT)	4
23	B10-P3439	CYLINDER PIN (LOWER)	1
24	B10-503720	BASE CYLINDER COMPLETE	1
	B10-599000	O-RING KIT FOR CYLINDER	1
25	B10-Q3585	TEE	1
26	B10-X5514	CLAMPING SLEEVE	1
27	B10-X5513	OVERFLOW HOSE (1280 mm)	1
28	B10-Q9917	PROTECTIVE SPRING	1
30	B10-R3195	CYLINDER PIN (UPPER)	1
31	B10-D3176	HIGH PRESSURE HOSE (520 mm)	1
32	B10-Q6241	BRASS RING	1
33	B10-F3470	O-RING	1
34	B10-Q6237	U-CLIP	1
35	B10-T1027	ELBOW	1
36	B10-P3440	LINK PIN (LOWER)	1
37	B10-P3443	SUBLINK (RIGHT)	1
38	B10-X5043	NYLON CLAMP	1
39	B10-R3196	SUBLINK SHAFT (RIGHT)	8
40	B10-K3181	LINK BRACKET (RIGHT)	1
41	B10-U3332	SAFETY PLATE BUMPER (SEPARATE) BLACK ONLY	1
42	N/N	SCREW (M4.5 x 10 mm)	1
43	B10-HAPE05A0	NEW PUMP COVER (WHITE)	4
44	B10-HAPE08A0	NEW PLASTIC BASE COVER (WHITE)	1
45	N/N	FASTENERS (5/REG. & 1/SHORT) FOR BASE COVER	1
	B10-503909	BASE & LINK COVER SET (WHITE)	6
	B10-503910	BASE & LINK COVER SET (BLACK)	1

CANTILEVER ARM ASSEMBLY

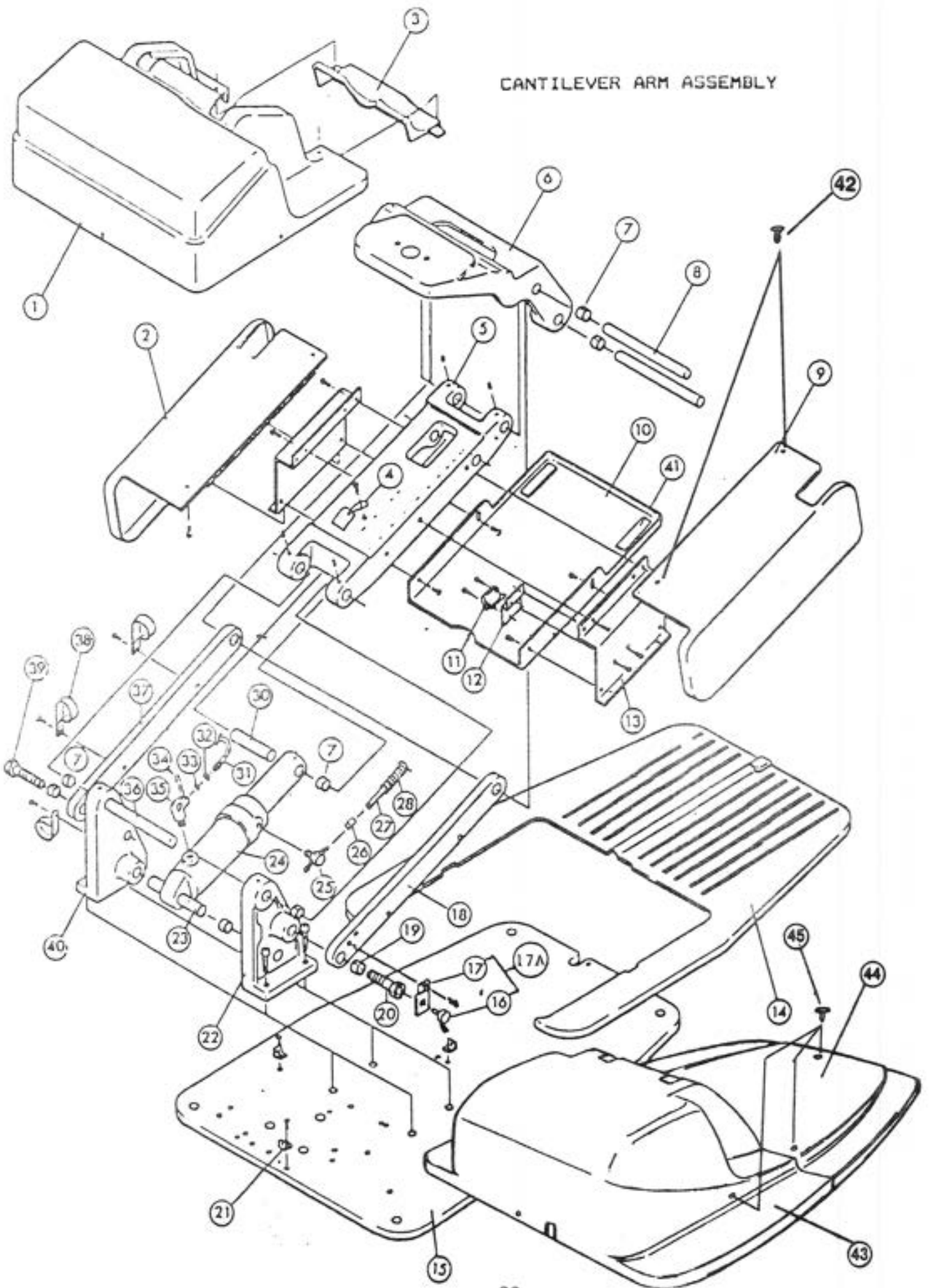

BASE SECTION ASSEMBLY

INDEX NO.	PART NO.	DESCRIPTION	QTY
1	B10-G0063	SUPPORT BRACKET	1
2	B10-X8083	SOLENOID VALVE ASSEMBLY	1
3	B10-F3470	O-RING	4
4	B10-Q6241	O-RING RETAINER	4
5	B10-R3491	HIGH PRESSURE HOSE (320 mm)	1
6	B10-D3176	HIGH PRESSURE HOSE (520 mm)	1
7	B10-U5035	HIGH PRESSURE HOSE (1400 mm)	1
8	B10-Q2279	LOW PRESSURE HOSE (320 mm)	1
9	B10-X5557	LOW PRESSURE HOSE	1
10	B10-F2268	HOSE CLAMP	4
11	B10-F6170	OIL CAP	1
12	B10-Q2069	NUT	1
13	B10-Q3252	OIL RESERVOIR BRACKET	1
14	B10-F6142	OIL FILTER	1
15	B10-F2269	CLAMP	2
16	B10-T1027	ELBOW	1
17	B10-F6133	STRAINER	1
18	B10-F2409	ELBOW	1
19	519-10060	MOTOR PUMP ASSEMBLY	1
20	B10-Q2247	MOTOR CLAMP	1
21	B10-R1214	MOTOR MOUNT	3
22	B10-X5557	LOE PRESSURE HOSE (400 mm)	1
23	B10-Q2438	ELBOW	1
24	B10-Z0067	RELAY BOX ASSEMBLY W/P.C. BOARD	1
25	B10-F3190	WIRE BRACKET	1
26	B10-A3098	BASE PLATE	1
27	B10-X5002	CAPACITOR	1
28	B10-E6057	CAPACITOR COVER	1
29	B10-X2801	TRANSFORMER	1
30	B10-A3099B	BASE MAT (BLACK)	1
	B10-A3099G	BASE MAT (GREY)	1
31	B10-C3244	RESERVOIR	1

BASE SECTION ASSEMBLY

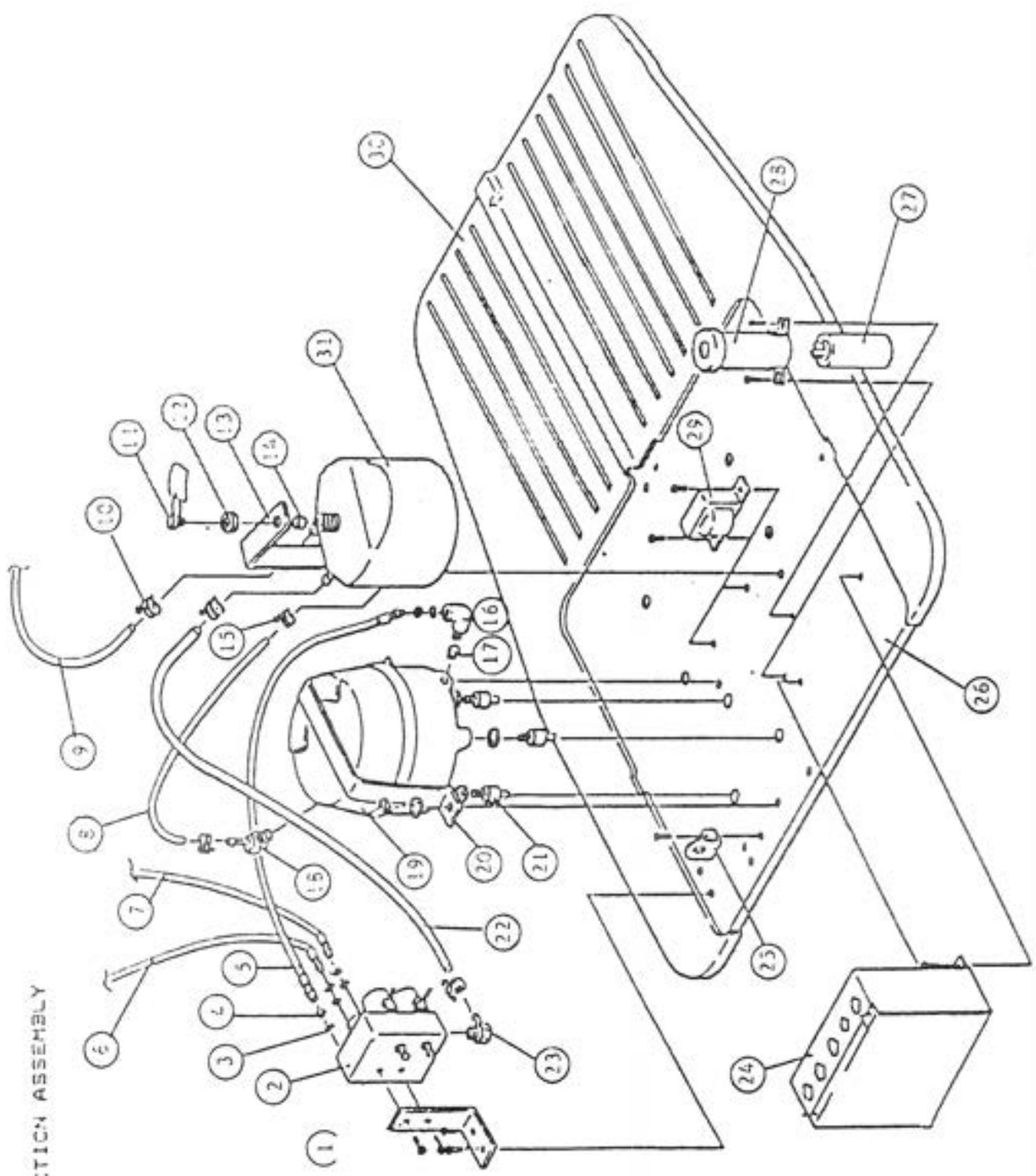

BACKREST/HEADREST ASSEMBLY

INDEX NO.	PART NO.	DESCRIPTION	QTY
1	B10-A3725	BACKREST FRAME COVER	1
2	B10-N3704	SWITCH GUARD LEFT (WHITE)	1
3	B10-N3703	SWITCH GUARD RIGHT (WHITE)	1
4	B10-X6521	SWITCH BOARD ASSEMBLY	1
5	B10-X6595	SPACER FOR SWITCH	4
6	B10-503902	BACKREST SWITCH ASSEMBLY (LEFT)	1
7	B10-503901	BACKREST SWITCH ASSEMBLY (RIGHT)	1
8	B10-S3739	SPRING BAR	1
9	B10-S3740	RUBBING BLOCK	1
10	B10-S3738	SPRING HOLDING PLATE	1
11	B10-U3534	HEADREST GUIDES	2
12	B10-T3974	HEADREST GUIDE PLATE	1
13	B10-503903	HEADREST GUIDE ASSEMBLY	1
14	B10-X6520	BACKREST CONNECTING BOARD	1
15	B10-X6337	SPACER FOR CONNECTING BOARD	2
16	B10-Y7083	SNAPS FOR UPHOLSTERY	8
17	B10-R3246	ANGLE BRACKET	2
18	B10-L3605	BACKREST FRAME	1
19	B10-350851B	HEADREST COMPLETE W/O CUSHION (BLACK GRIP)	1
	B10-350851W	HEADREST COMPLETE W/O CUSHION (WHITE GRIP)	1
20	B10-350852B	HEADREST COMPLETE W/ CUSHION (BLACK GRIP)	1
	B10-350852W	HEADREST COMPLETE W/ CUSHION (WHITE GRIP)	1
21	N/N	SCREW (M3 x 10 mm)	2
22	N/N	SCREW (M3.5 x 7 mm)	4
23	N/N	SCREW (M3.5 x 5.5 mm)	4
24	N/N	SCREW (M3.5 x 11 mm)	2
25	N/N	SCREW (M5.5 x 24 mm)	4
26	N/N	SCREW (M4.5 x 10 mm)	2
27	N/N	SCREW (M10 x 30 mm)	4
28	N/N	SCREW (M7 x 24 mm)	4
29	VFA-A3725	B/R WHITE PLASTIC FRAME COVER FOR PURITY	1
30	VFA-X6794	HEADREST WHITE PLASTIC COVER FOR PURITY	1
31	B10-H3829	BACKREST FRAME COMP. BLACK UPH.	1
32	B10-X6794	BACKREST VELCRO STRIPS	2
33	B10-X6780	BACKREST FRAME UPH. COVER	1

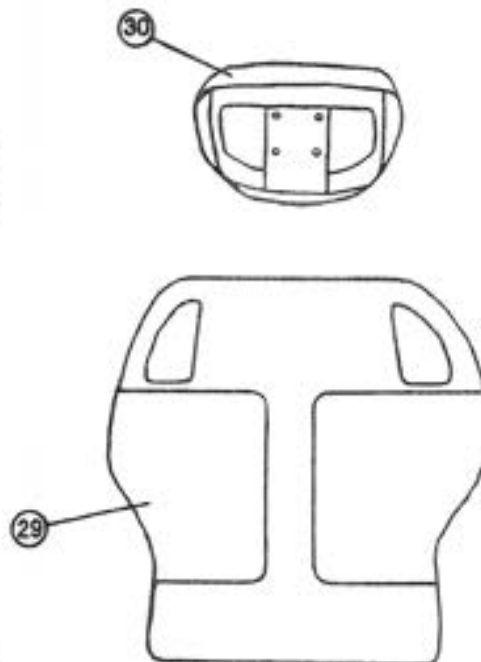
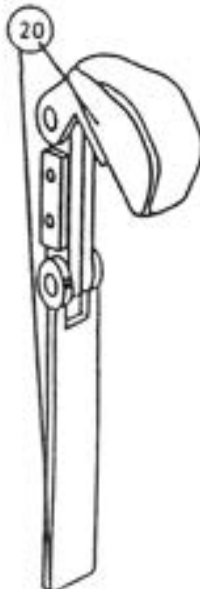
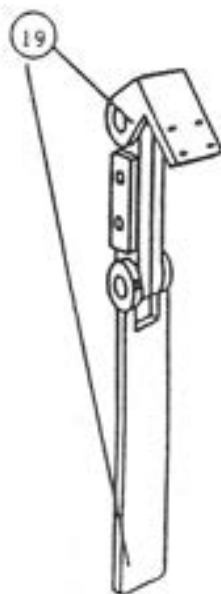

BACKREST/HEADREST ASSEMBLY

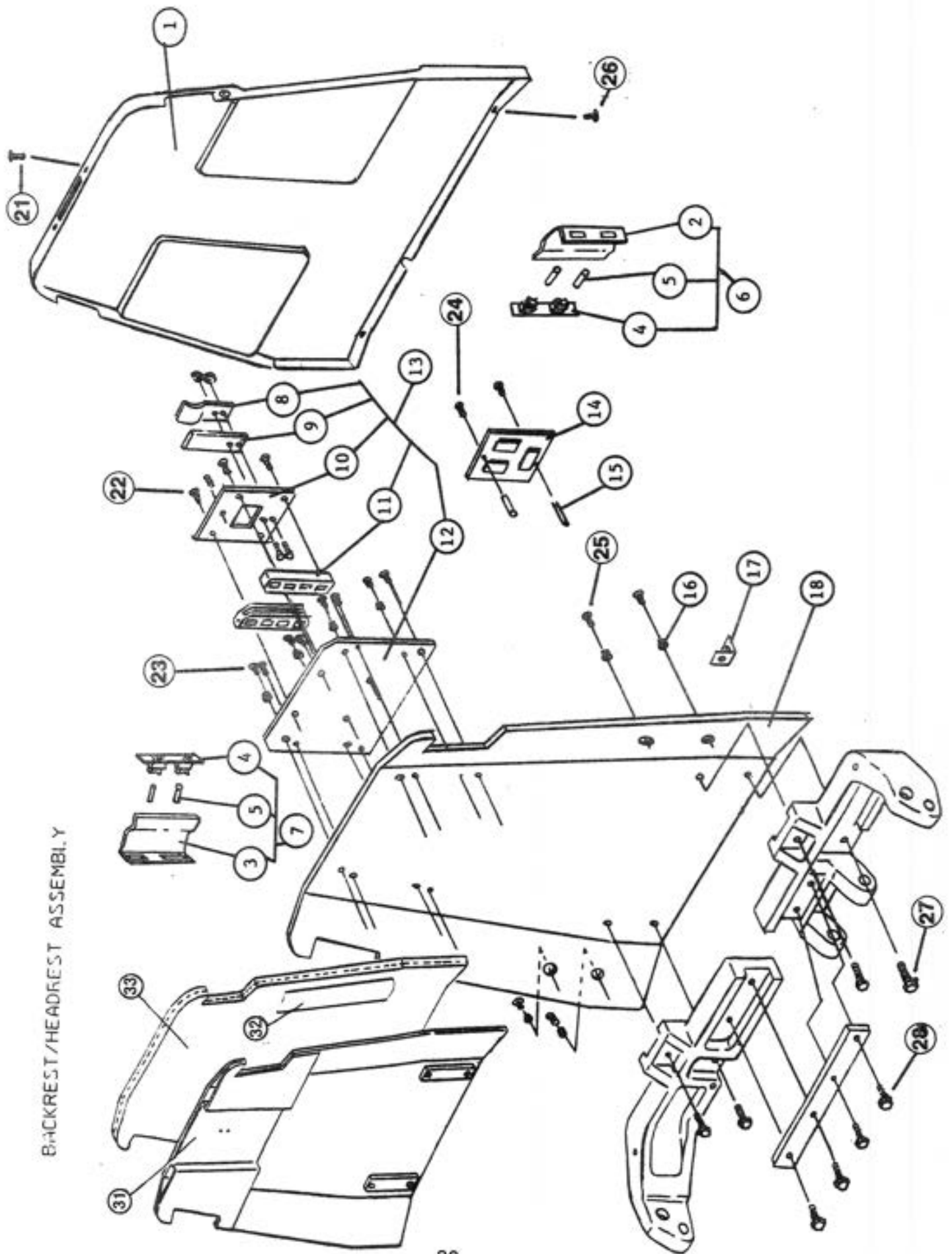

FOOT CONTROL ASSEMBLY

INDEX NO.	PART NO.	DESCRIPTION	QTY
1	B10-X7322	LABEL	1
2	B10-T3271B	DISC (BLACK)	1
	B10-T3271G	DISC (GREY)	1
3	B10-U3135	CAP	1
4	B10-K3276B	RUBBER COVER (BLACK)	1
	B10-K3276G	RUBBER COVER (GREY)	1
5	B10-K3275	FOOT CONTROL BODDY	1
6	B10-U3180	RUBBER SPRING	1
7	B10-X7325	SWITCHES	6
8	B10-X7898	FOOT CONTROL P.C. BOARD W/SWITCHES	1
9	B10-X5052	NYLON CLAMP	1
10	B10-K3191	SWITCH PLATE	1
11	B10-503780B	FOOT CONTROL COMPLETE (BLACK)	1
	B10-503780G	FOOT CONTROL COMPLETE (GREY)	1
12	B10-X7899	FOOT CONTROL WIRE HARNESS	1
13	N/N	SCREW (M4 x 46 mm)	4
14	N/N	SCREW (M3.5 x 15.5 mm)	4
15	N/N	SCREW (M3.5 x 15.5 mm)	3

FOOT CONTROL ASSEMBLY

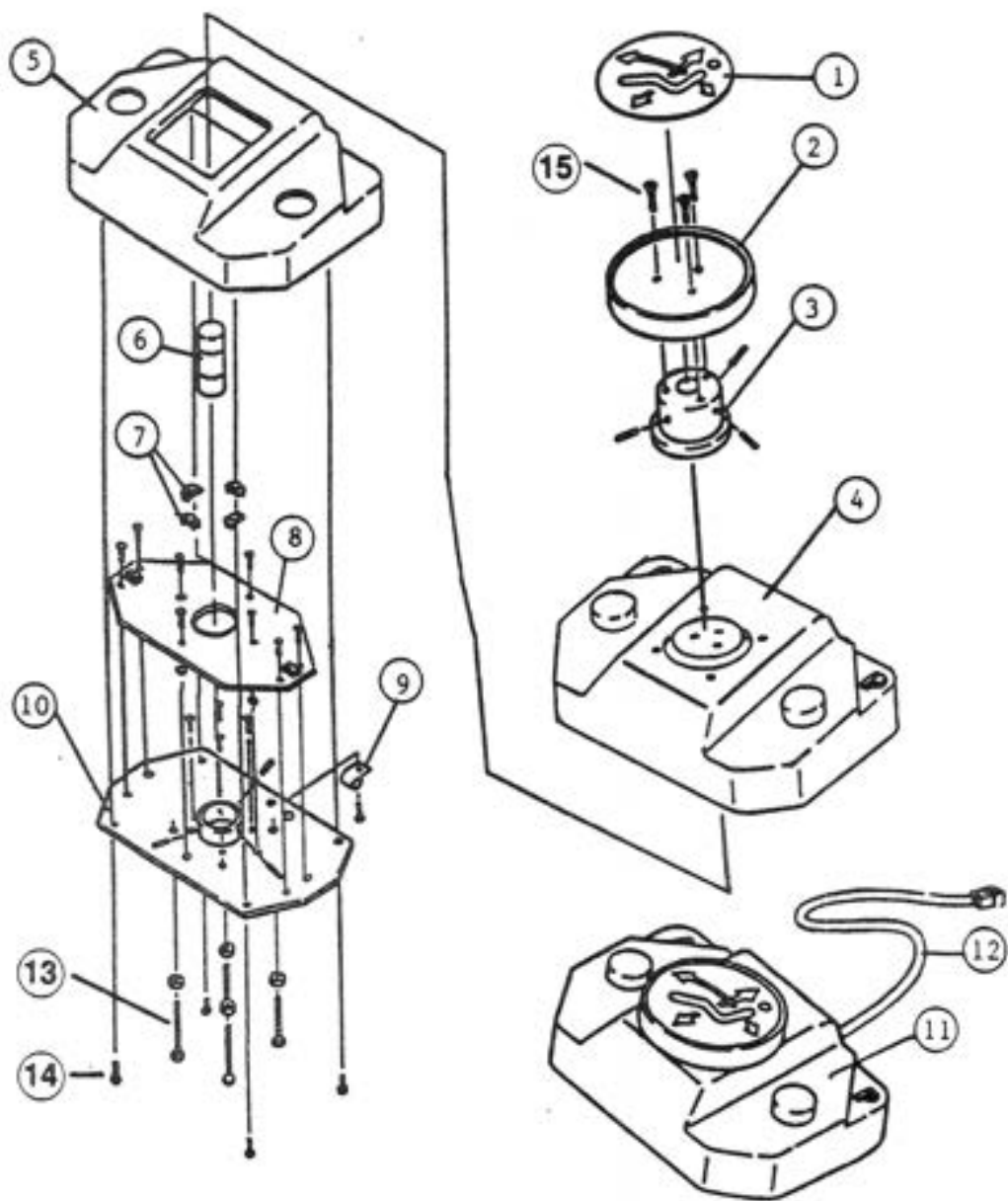

UPHOLSTERY PARTS SECTION

INDEX NO.	PART NO.	DESCRIPTION	QTY
1	B10- X6792	BACKREST CUSHION FOR STANDARD	1
2	B10- X6797	BACKREST CUSHION FOR STANDARD W/SNAPS	1
3	B10- X6791	SEAT & LEGREST CUSHION FOR STANDARD	1
4	B10- B3643	LEGREST PROTECTOR FOR STANDARD	1
5	B10- Y7081	BACKREST CUSHION FOR SEAMLESS	1
6	B10- Y7080	BACKREST CUSHION FOR SEAMLESS W/SNAPS	1
7	B10- Y7082	SEAT & LEGREST CUSHION FOR SEAMLESS	1
8	B10- X6793	HEADREST CUSHION	1
	VFA- X6793	HEADREST CUSHION FOR PURITY	1
9	B10- B3644	LEGREST PROTECTOR FOR SEAMLESS	1
10	VFA- X6791	SEAT & LEGREST CUSHION FOR PURITY	1
11	VFA- X6797	BACKREST CUSHION FOR PURITY	1
12	VFA- X6795	LEGREST PROTECTOR FOR PURITY	1
13	B10-40800	FLAT HEADREST W/DONUT CUSHION FOR BEL-10	1

*** NOTE : UPH FOR BLACK CHAIR HAS VELCRO.
 UPH FOR WHITE CHAIR HAS SNAPS. ***

UPHOLSTERLY PARTS

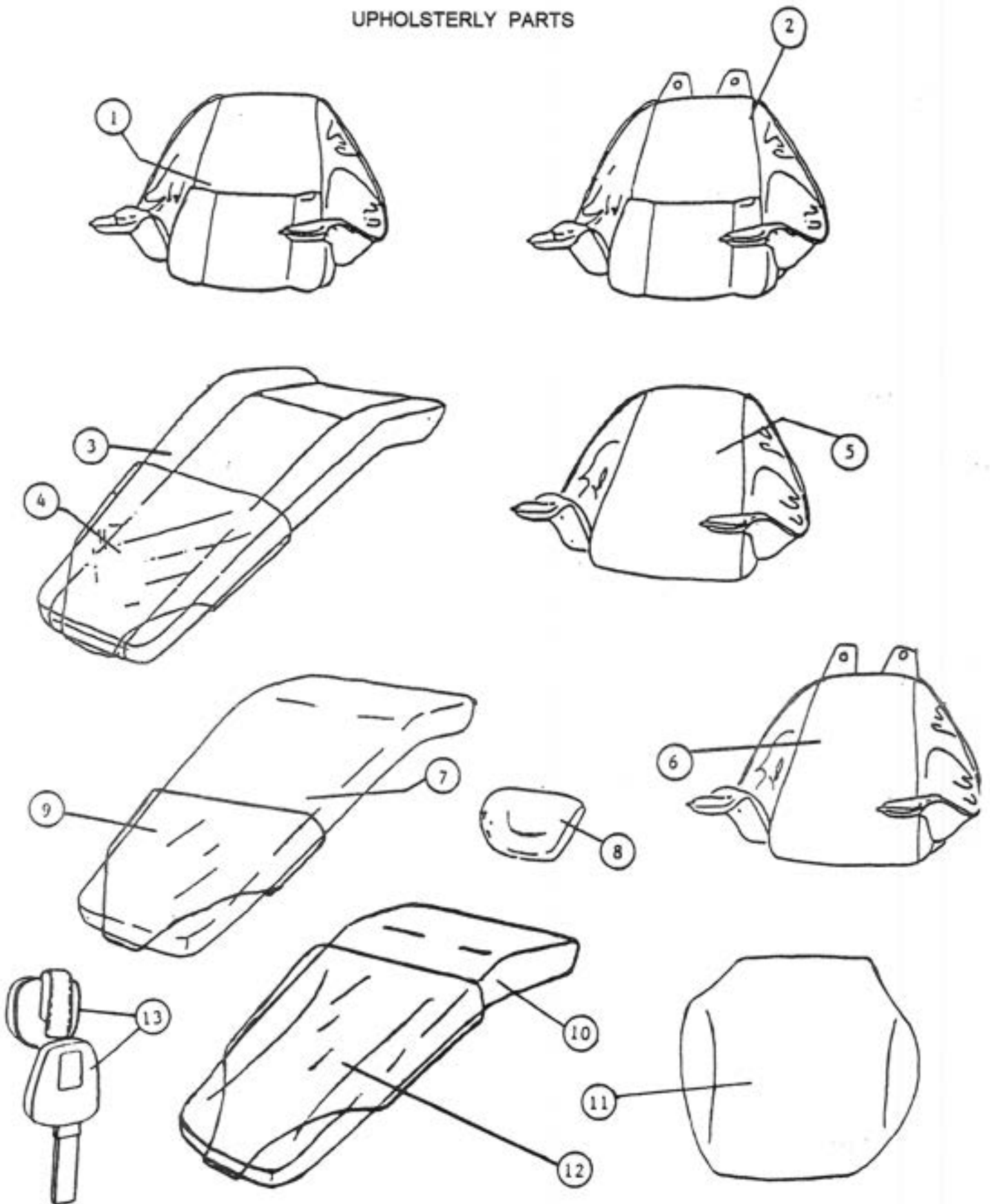

WIRING SCHEMATIC PARTS LIST

INDEX NO.	PART NO.	DESCRIPTION	QTY
1	B10-AB0006	POWER CORD	1
2	B10-Z0067	RELAY BOX ASSEMBLY	1
3	B10-503780	FOOT CONTROL COMPLETE	1
4	B10-X2801	TRANSFORMER	1
5	B10-503904	POTENTIOMETER W/BRACKET F/RECLINE	1
	B10-503905	POTENTIOMETER W/BRACKET F/BASE	1
W-6	B10-X6528	WIRE HARNESS F/UPPER POT. TO LOGIC P.C.B. (S6)	1
7	B10-X6313	MICRO SWITCH	1
W-8	B10-X6526	WIRE HARNESS F/SAFETY SW TO LOGIC P.C.B. (S3)	1
W-9	B10-EB0014	WIRE HARNESS F/TRANS. TO LOGIC P.C.B. (CN6)	1
W-10	B10-X6531	WIRE HARNESS F/RALAY BOX TO LOGIC P.C.B. (S4)	1
W-11	B10-X7899	FOOT CONTROL WIRE HARNESS	1
12	B10-X6519	LOGIC P.C. BOARD	1
W-13	B10-X6530	WIRE HARNESS F/LOGIC P.C.B. (S1) TO BACKREST	1
W-14	B10-X6527	WIRE HARNESS F/LOWER POT. TO LOGIC P.C.B. (S5)	1
W-15	B10-X6525	WIRE HARNESS F/BACKREST CONNECTOR BOARD	1
16	B10-X6520	BACKREST CONNECTING BOARD	1
W-17	B10-X6524	WIRE HARNESS F/B/R SWITCH(R) TO B/R CON. BOARD	1
18	B10-X6521	SWITCH BOARD ONLY	2
W-19	B10-X6523	WIRE HARNESS F/B/R SWITCH(L) TO B/R CON. BOARD	1
20	B10-T3430	SOLENOID VALVE ASSEMBLY	1
21	B10-D6065	MOTOR PUMP ASSEMBLY (5L)	1
22	B10-X5002	CAPACITOR	1
W-23	B10-X6532	WIRE HARNESS F/SOLENOID VALVE TO RELAY BOX	1
W-24	B10-X6529	WIRE HARNESS F/LOGIC P.C.B. TO F/C WIRE HARNESS	1

*** NOTE : ITEMS MAKED WITH "W" ARE WIRES. ***

ELECTRICAL SCHEMATIC

