

# *Belmont Dental Delivery Systems*

*Installation Instructions:  
Swing Mounted Unit With Light*

***BDS2572***

***BDS2573***

***BDS2578***

X-Calibur Units



# Swing Mounted Style

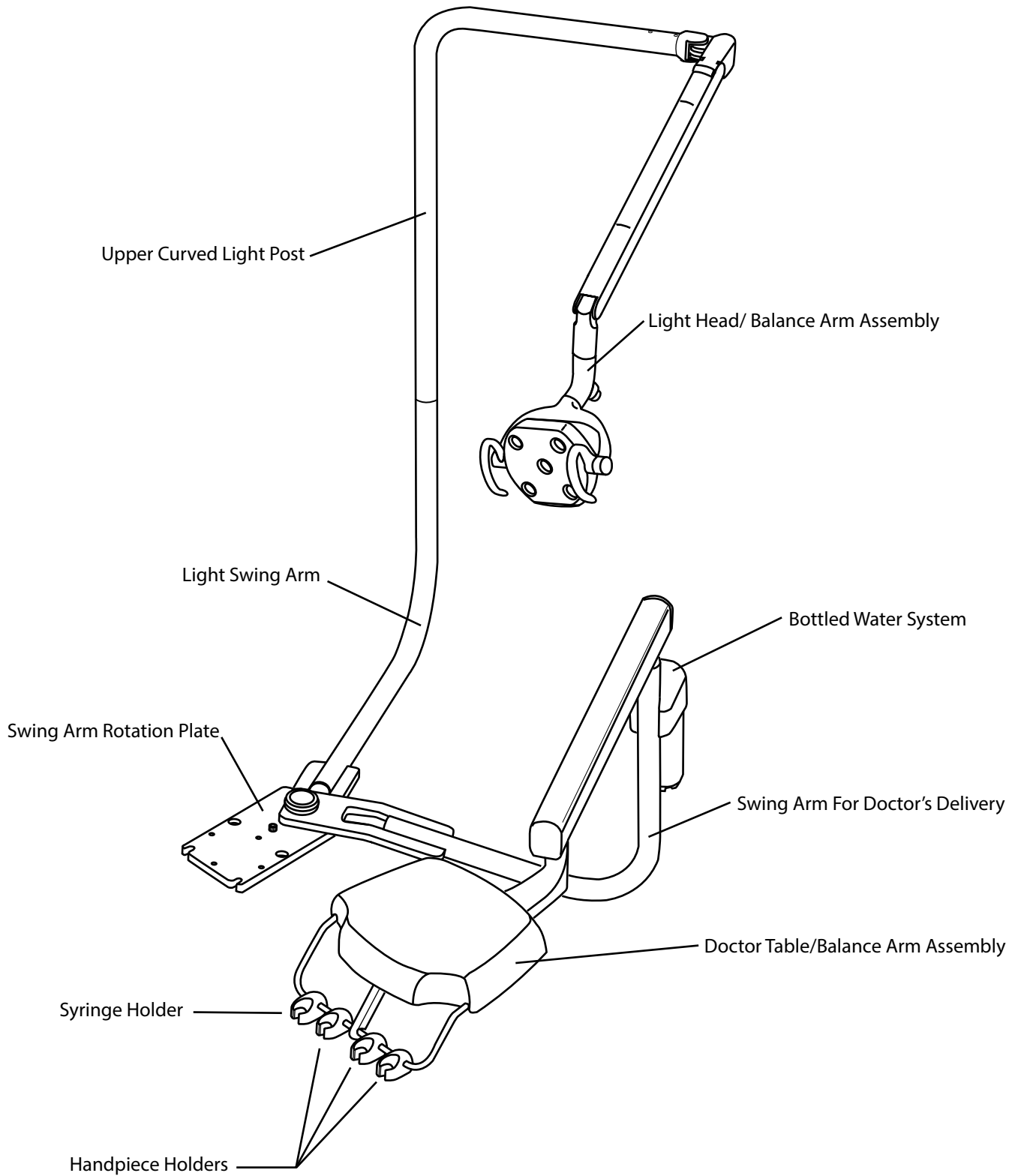

*Installation Instructions  
for BDS Swing-Mounted Delivery With Curved Post Dental Light  
X-Calibur Dental Units*

**BDS Swing Mounted Unit with Curved Post Light**

Installation Time: Approximately 2 hours

Shipping Packages:

3 Boxes:

- 1- Doctor Table/Arm Assembly
- 1- Dual Swing Arm Assembly with J-box Components
- 1- Belmont Curved Post Light with Upper Curved Post, Transformer and Sensor-Switch Box

Tools Needed:

- Hex key wrench set or socket drive set
- Adjustable wrench
- Slotted screwdriver
- Phillips head screwdriver
- Bubble Level
- Wire cutter
- Masking Tape
- (Silicone Spray Lube)

1. Open large shipping carton that contains the Swing Arm Assembly. This package contains a smaller box where the Swing Mount Bracket and Mounting Hardware are located.

Remove Swing Mount Bracket and bag of hardware.

2. Locate and install (4) 4mm x10 mm screws into the bottom side of the Swing Mount Bracket using a Phillips screwdriver, as shown below. This step clears excess paint from threaded holes.

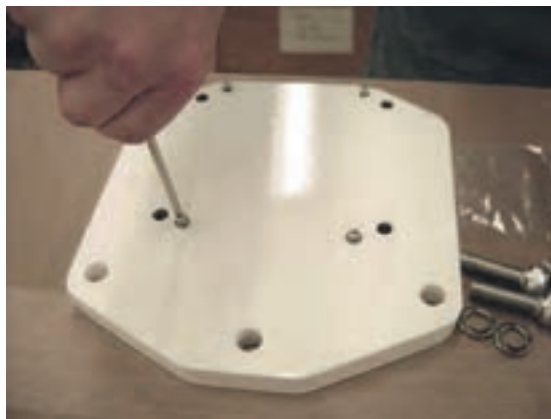

B50N Chair Swing Mount Bracket (8-Sided Plate)

3. Attach the Chair Mounting Plate to B50N chair using hardware provided (also attaches to B50, B20N, B20+ and B20).

Chair Mounting Plate is attached on the top of the gray chair casting extension as shown below. Attach Plate to chair using a 10 mm hex key wrench to tighten the (3) 12mm x 55 mm socket bolts with 12mm spring washers

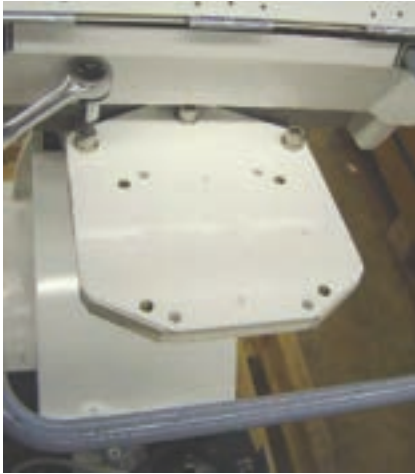

Delivery System Mounting Plate is attached on top of the gray extension casting on B50N chairs



Attached mounting bracket, seen from below. Note (4) 4mm x 10mm Phillips screw heads face down. (These are used for mounting sensor/switch box for dental light )

#### 4. Attaching the Swing Arm Assembly

**IMPORTANT! :**

**Reset lower chair limit position after attaching the Swing Arm Assembly to the chair. Damage to J-Box, chair base & lift arm covers and swing arm can result from improperly set lower limit position. Please refer to chair manufacturer's instructions for setting lower limit of travel.**

Remove Swing Arm Assembly from shipping package and place Rotation Plate on the top side of the Swing Mounting Bracket.

Use an 8 mm hex key wrench to partially tighten Swing Arm Assembly to Swing Mounting Bracket as follows:

Add (2) 10mm x 40mm socket bolts with spring washers to front recessed holes on Swing Arm Rotation Plate and partially tighten to support Swing Arm Assembly.

Place the Bracket for umbilical hose on top of the Swing Arm Rotation Plate and align the back/inside hole with threaded hole of Chair Mounting Plate underneath the slotted end of the Rotation Plate. Add 10mm x 40mm socket bolt with 10mm spring washer and 10 mm flat washer. Add remaining bolt/split ring washer/ flat washer to secure other slotted end of rotation plate. Use an 8 mm wrench to partially tighten assembly.

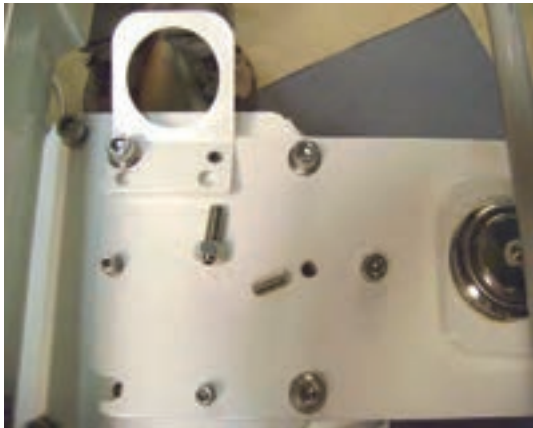

Bracket for Umbilical Hose is secured using socket bolt with spring washer and flat washer. Note: M10 x 20 leveling set screws & M10 x 35 leveling set screw with nut shown.

Insert long (35mm) leveling set screw with locking nut through hole in Umbilical Mounting Bracket, as shown above. Nut should be tightened after final leveling of swing arms & unit.

## 5. Swing Arm Leveling

- a) Using an 8mm hex key wrench, add (1) M10 x 35 through hole in Umbilical Mounting Bracket (as shown above, at right) and (3) M10 x 20 Leveling Set Screws to the top of Rotation Plate.
- b) Place a bubble level on top of the flat surface of the Rotation Plate and check Swing Arm Assembly leveling. Adjust the Leveling Set Screws for rough leveling, as indicated by bubble level.
- c) Gradually tighten (4) M10 x 40 Socket Bolts to secure Rotation Adapter to Swing Mounting Bracket, making adjustments to Leveling Set Screws, as necessary.

### **NOTE:**

**Final leveling of Swing Arm Assembly should be repeated and adjusted after Doctor Table/ Balance Arm Assembly & Light Assembly have been attached to the Swing Arm Assembly.**

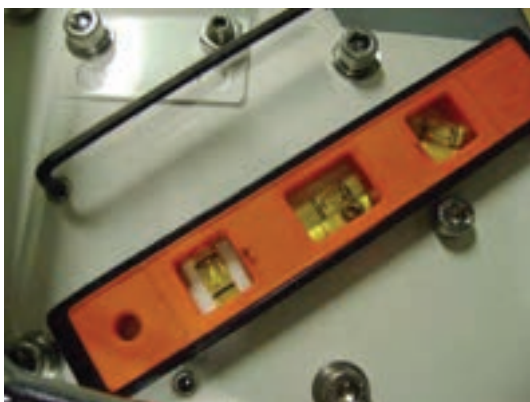

Adjusting (4) set screws for leveling of Swing Arm Assembly

## 6. Attaching the Swing Arm Bottled Water System Assembly

- a) Using a Phillips screwdriver, remove M6 x 20 mounting screw for water bottle bracket from unit Swing Arm.



Use Phillips screw driver to remove 6mm x 20mm water bracket mounting screw

- b) Remove Bottled Water System assembly and Cover from box containing J-Box Accessories. Insert 1/8" blue and 1/8" brown tubing (with gray outer sleeve) from water system into hole on the side of the swing arm and route downward through swing arm.



Insert 1/8" blue & brown tubing into the hole on the side of the swing arm and feed tubing down through bottom end of the Swing Arm

- c) Feed lower end of the blue flexible ribbon wire through center hole in the Water Bottle Mounting Bracket.

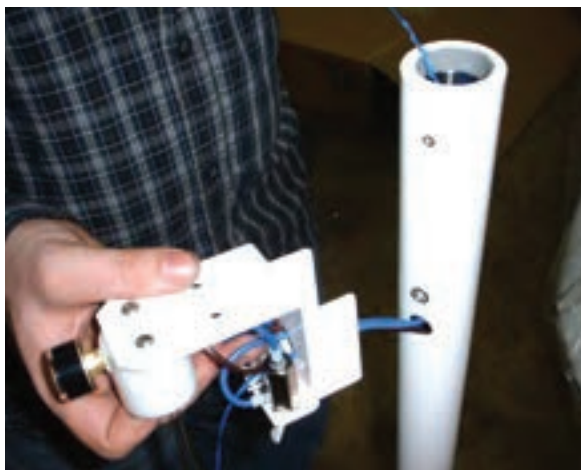

- d) Use a slotted screwdriver to remove one 10-32 x 1/2" screw from top of the Water Bottle Mounting Bracket and loosen the second screw.

Rotate Water Bottle Manifold to get better access for tightening the Water Bottle Mounting Bracket to the Swing Arm.



e) Replace 6mm x 20 mm Phillips mounting screw and tighten Water Bottle Mounting Bracket to Swing Arm.



#### 7. Installing Doctor Table/Balance Arm Assembly onto Swing Arm

- a) Open Doctor Table/ Balance Arm Assembly shipping carton.
- b) Remove plastic fitting bag tied to the end of the unit umbilical.
- c) Attach flexible ribbon wire from Balance Arm Assembly umbilical to blue flexible ribbon at top of Swing Arm. Pull flexible ribbon through Water Bottle Mounting Bracket.



Pull flexible ribbon wire with blue & brown tubing from unit umbilical down & out through the routing hole of the Water Bottle Mounting Bracket.

- d) Insert end of Touchpad Wire Harness (gray insulation) into the top of the Swing Arm and feed downward.



Feed Touch Pad Wire Harness down through Swing Arm.

(Note: A light application of Silicone Spray to the outside of main umbilical tubing and wire harnesses will ease passage through the Swing Arm)

- e) Lift Doctor Table/ Balance Arm Assembly out of the shipping carton and support on shoulder. Feed main umbilical down into Swing Arm.



Mount Doctor Table/ Balance Arm Assembly to Swing Arm.  
Feed umbilical and touchpad wire harness downward and gradually pull green flexible ribbon attached to ends of 1/8" brown & 1/8" blue tubing through hole in Water Bottle Mounting Bracket.



Mount Balance Arm onto Swing Arm.

Note: plated Balance Arm joint must be fully seated onto Swing Arm.

Push Umbilical and Touch Pad Wire Harness downward, while gradually pulling ribbon wire attached to 1/8" brown and 1/8" blue tubing through Water Bottle Mounting Bracket.

- f) Remove M x set screw and 4mm hex key wrench from the small bag attached to water bottle (shipped inside J-Box carton).  
 Insert the set screw into the threaded hole at the top of the Swing arm.  
 Tighten set screw to minimize drift of Doctor Table/Balance arm Assembly.  
 (Units shipped prior to spring of 200 require installation of a brass friction disc prior to addition of setscrew. Failure to add brass disc to these units will result in permanent damage to unit balance arm pivot).

**IMPORTANT !:**  
**Do Not Over-Tighten Set Screw.**  
**Over tightening will strip the thread inside the Swing Arm.**

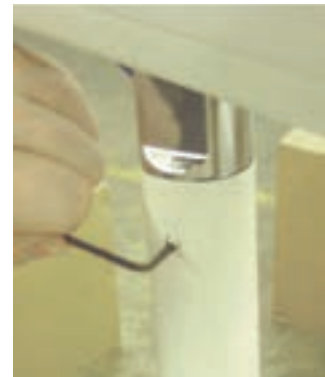

Set Screw and Hex key Wrench are shipped in a bag attached to the water bottle inside of the Box. Insert the 4mm x 4mm set screw into threaded hole on the Swing Arm and tighten to minimize drifting of Balance Arm

**DO NOT OVERTIGHTEN SET SCREW**

. Connecting Bottled Water System to Doctor Table Section

- a) Trim 1/8" brown tubing from Dr. Table/ Balance Arm Assembly to desired length for connection to the open barb on the Tee fitting on the Water Bottle System Bracket.  
 Note: Allow enough tubing length to prevent kinking.  
 Slip 1/8" tubing collar onto tubing and connect and secure tubing to Tee fitting.

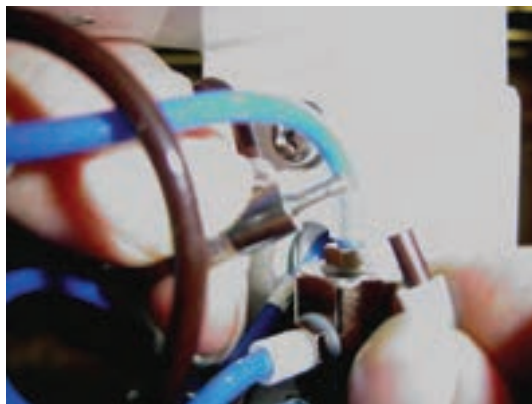

Slip tubing collar over trimmed end of 1/8" brown tubing and insert tubing onto Tee. Secure tubing collar down over barbed tubing connection.

- b) Trim 1/8" blue tubing from Dr. Table/ Balance Arm Assembly to desired length for connection to the open barbed fitting on the Water Selector valve attached to the Water Bottle System Bracket. Allow a little extra length of tubing to prevent kinking.

Slip 1/8" tubing collar onto tubing and connect and secure tubing to barbed fitting on the Water Selector Valve.



Slip tubing collar over trimmed end of 1/8" blue tubing and insert tubing onto Water Selector Valve. Secure tubing collar down over barbed tubing connection.

c) Replace 10-32 slotted screw from step 6, d) and re-tighten both screws.

d) Attach Water Bottle System Assembly Housing Cover to Bracket using (2) 4mm x 16mm self-tapping Philips screws, as shown below.



e) Secure Unit umbilical to Swing Arm Pivot using Nylon C-clamp and M4 x 10 Philips screw provided.



## 9. Unpacking Dental Light Components

- a) Unpack Upper Curved Light Post and Dental Light subassembly.
- b) Loosen the flexible pull-string ribbon on Upper Curved Light Post, but do not remove it.
- c) Remove accessory bag taped to Upper Curved Light Post. Bag contains: (1) set screw for setting light post friction to overcome minor light post drifting issues and a hex key wrench. (Note: Prior to March 2020, light posts used (3) brass friction discs and (3) setscrews to apply friction at 3 points. New light post uses a single set screw and an internal crush bushing.)
- d) Remove white plastic Washer from bottom of Curved Light Post and place onto the Light Swing Arm mounting stud.



Slip washer onto light swing arm mounting stud.

- e) Remove Dental Light and Balance Arm Assembly from carton.
- f) Unpack the Power Supply Box and the Sensor Switch Box from the shipping carton.



Sensor Switch Box, Power Supply Box and umbilical wire harness are packed inside of a small box inside of the light carton.



Sensor Switch Box attaches underneath the chair adapter



Umbilical wireharness is connected to the Power Supply Box during shipment

## 10. Assembling Dental Light to Upper Curved Light Post

- a) From Light Balance Arm Assembly, disconnect the jumper wires from the end of the wire harness and set aside for reattachment to the PCB inside of the sensor switch box in a later step.



Jumper wire harness with Ferrite is disconnected from light wire harness prior to inserting wire harness through light post and Light Swing Arm Mounting stud. Jumper will be re-connected to the Sensor Switch Box and the umbilical wire harness from the Power Supply Box in a later step

- b) Wrap connectors at the end of the light wireharness with a small amount of masking tape so it can be inserted into the Curved Light Post and into Light Swing Arm mounting stud.

## 11. Assembling The Dental Light and Upper Curved Light Post

- a) Remove the (2) M6 painted button head screws from the end of the Dental Light balance arm joint and set aside.

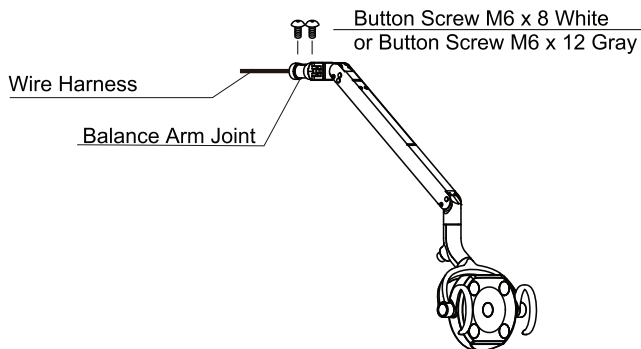

- b) Wrap electrical connectors at the end of the light wire harness with a small amount of masking tape and fasten the end of the ribbon pull-string to the end of the Upper Curved Light Post that has (2) thru holes.



Do not remove ribbon- wire pull-string when unwrapping light post.



Tape the connectors at the end of the wire harness from the light in a loose helix with masking tape



Wrap end of pull-string ribbon wire around taped connectors and insert into the Upper Curved Light Post at the end that has (2) holes

- c) Gently pull the pull-string ribbon and light wire harness through the Upper Curved Light Post



Gently pull the pull-string ribbon and wire harness through post and out of the bottom



Insert Light Balance Arm Joint into the Upper Curved Post and align holes in post with threaded holes in the Balance Arm Joint for re-attachment with the (2) M6 screws.

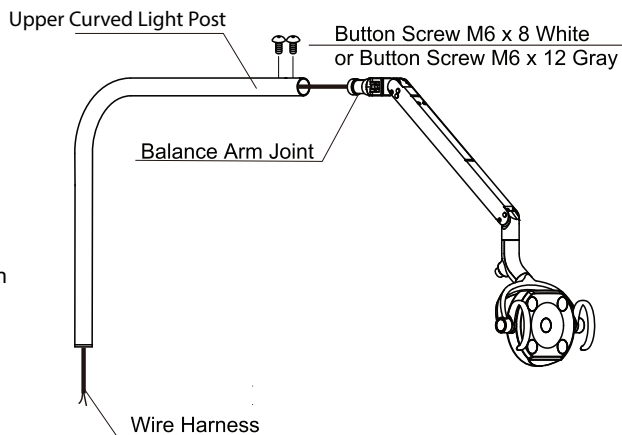

## 12. Attaching the Dental Light to the Light Swing Arm

- a) Route the pull-string ribbon and Wire Harness from the Dental Light into the stud at the top of the Light Swing Arm. Exercise care when feeding the electrical connectors into the narrow opening in the stud to prevent damage to wire harness.

Slide Upper Curved Light Post onto the Light Swing Arm stud, then add M6 x 5 set screw into the side of the post. This set screw is used to add friction to minimize light post drift on fully leveled units.

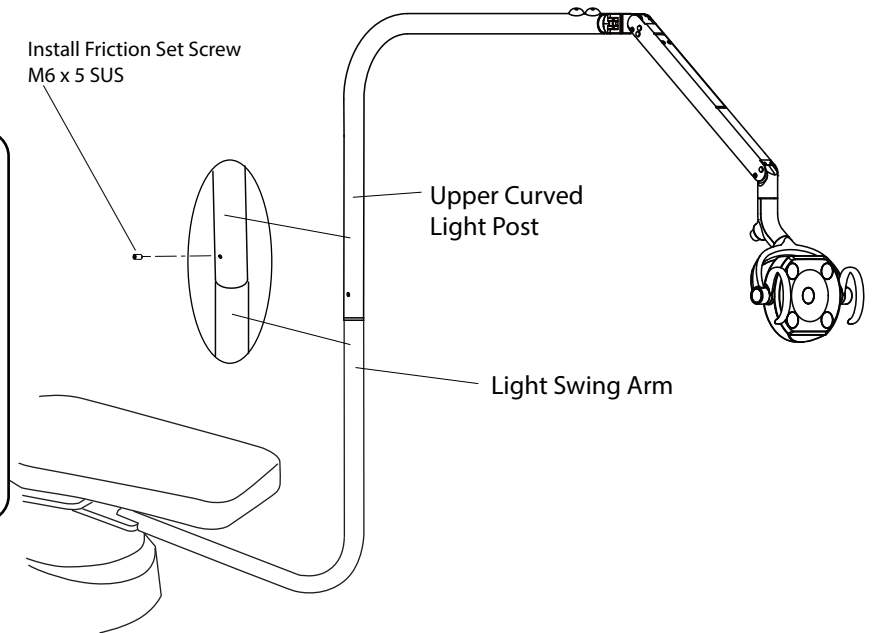
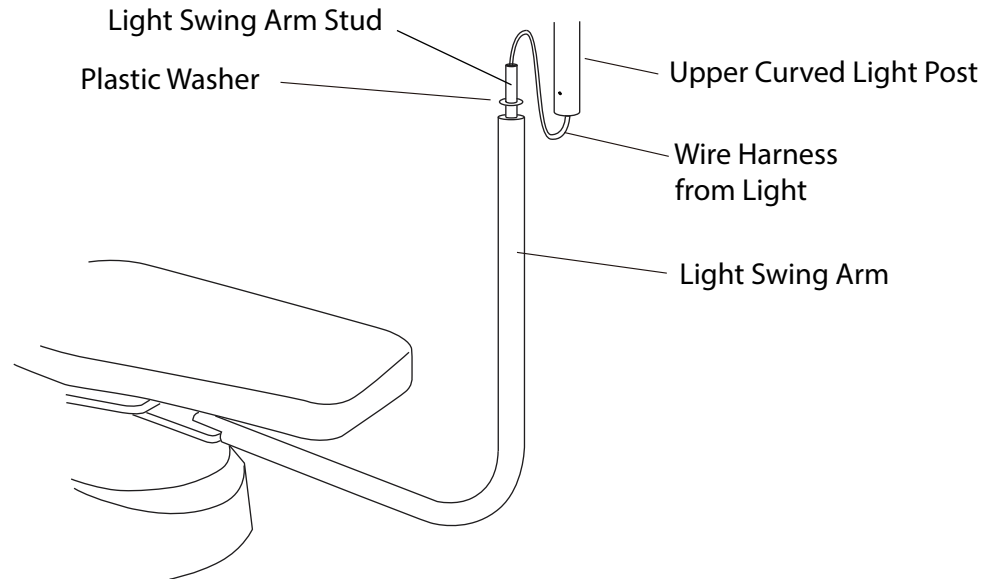

### Older Style Upper Curved Post Versions

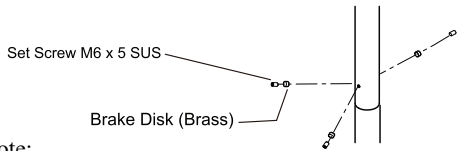

**Note:**  
Units shipped prior to Y2020 require (3) set screws and (3) brass friction discs inserted into the light post. Failure to add brass discs to these posts will result in permanent damage to light swing arm.

13. Attaching the Wire Harness From the Dental Light and the Umbilical Wire Harness From the Power Supply Box in J-Box

- a) Remove the Sensor Switch Box from carton. Using a Phillips screw driver, remove the (2) screws that fasten the cover to access the PCB. Connect Light and Umbilical Wire Harnesses to circuit board, then refasten the cover with the (2) Philips screws.  
 (See Clesta LED, Bel-Halo LED and Bel-Nova LED Sensor Switch Box Connections below.)

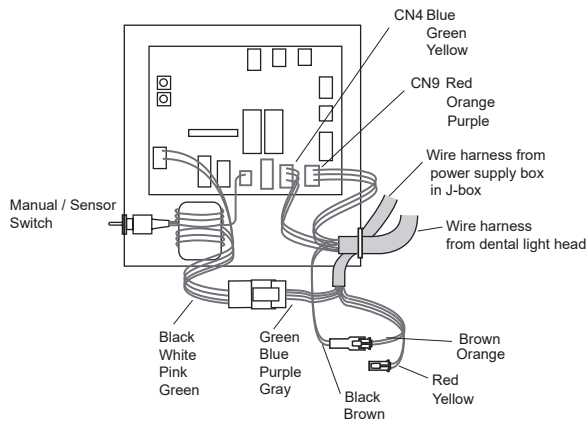
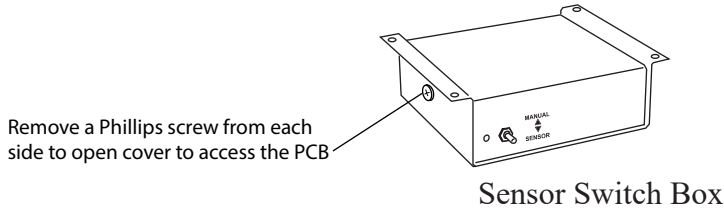

**Clesta LED Sensor Switch Box  
(Shipped with Model BDS2573)**

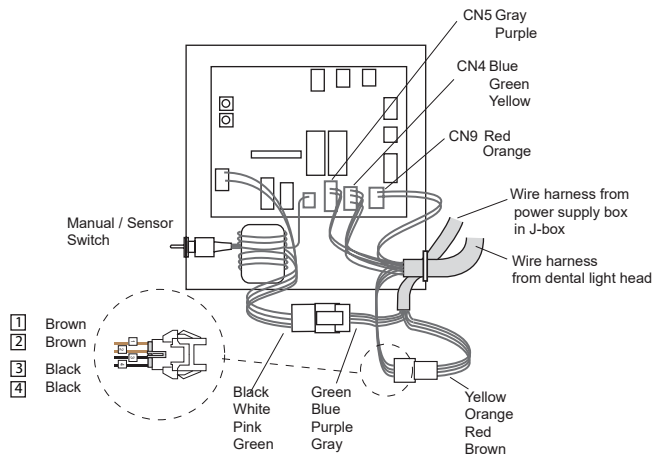

**Bel-Halo LED Sensor Switch Box  
(Shipped with Model BDS2572)**

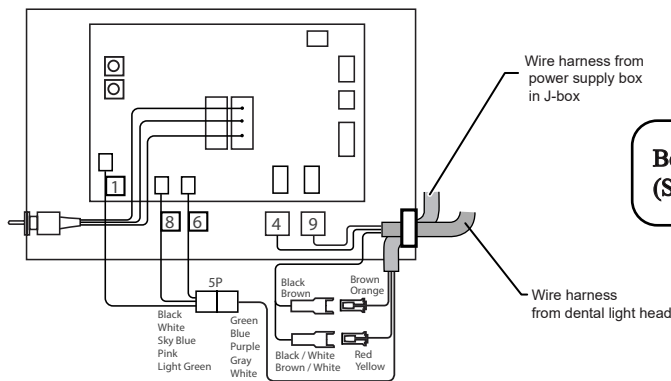

**Bel-Nova LED Sensor Switch Box  
(Shipped with Model BDS2578)**

14. Mounting Sensor/Switch Box Underneath the BDSSMB20 Chair Adapter.

- a). Remove (4) 4mm x 10 Phillips screws from the bottom side of the BDSSMB20 chair adapter.

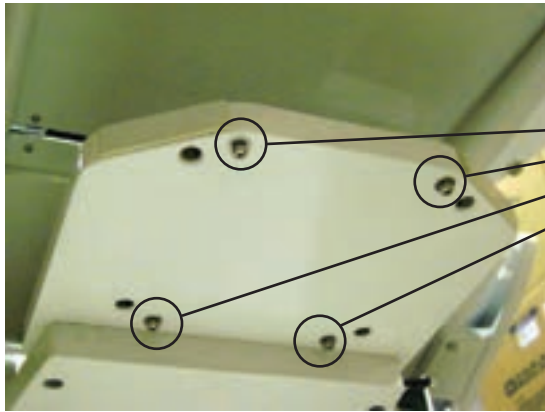

Remove (4) 4mm x 10 Phillips Screws for attaching the Sensor Switch Box

- b). Attach Sensor/Switch Box to the bottom of the chair adapter with the 4mm x 10 Philips screws.

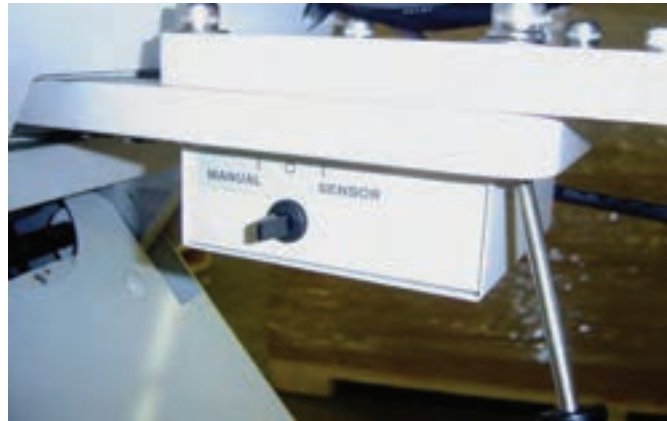

- c). Secure wire harness from the light to the nylon C-clamp on the swing arm rotation pivots.



## 15. Installing the Wire Harness From the Power Supply Box Through the Umbilical

- a) Wrap the end of wire harness to be routed through the Umbilical Duct Hose with masking tape. Apply a light coating of silicone spray to the outside of the wire harness and feed it through the Duct Hose and up through the Umbilical Bracket connector which was attached on the unit rotation plate.
- b) Feed the Lower Wire Harness for the dental light through the umbilical Duct Hose.  
(Note: lower end of wire harness is connected to the power supply box during shipment)



Apply a light coating of silicone spray to the outside of the tubing.

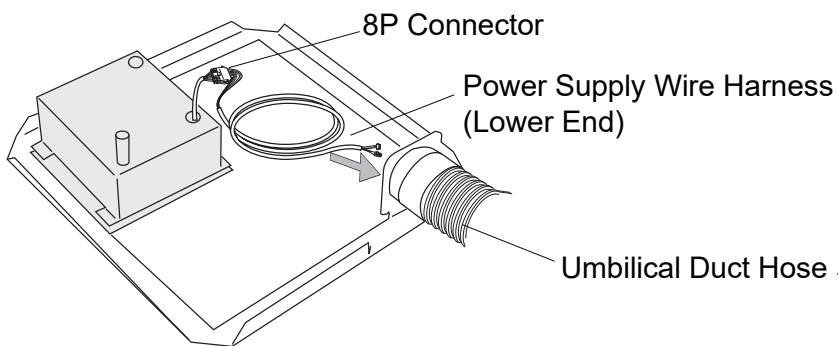

Power Supply Wire Harness  
(Upper End to Sensor Switch Box)

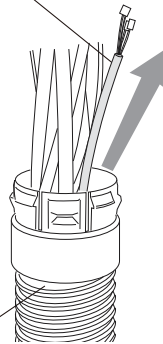

Umbilical Duct Hose is connected to the Umbilical Bracket on the Swing Arm Rotation Plate.

## 16. Connecting the Power Supply Box

a). Re-connect Wire Harness from the Sensor Switch Box with the Power Supply Box.

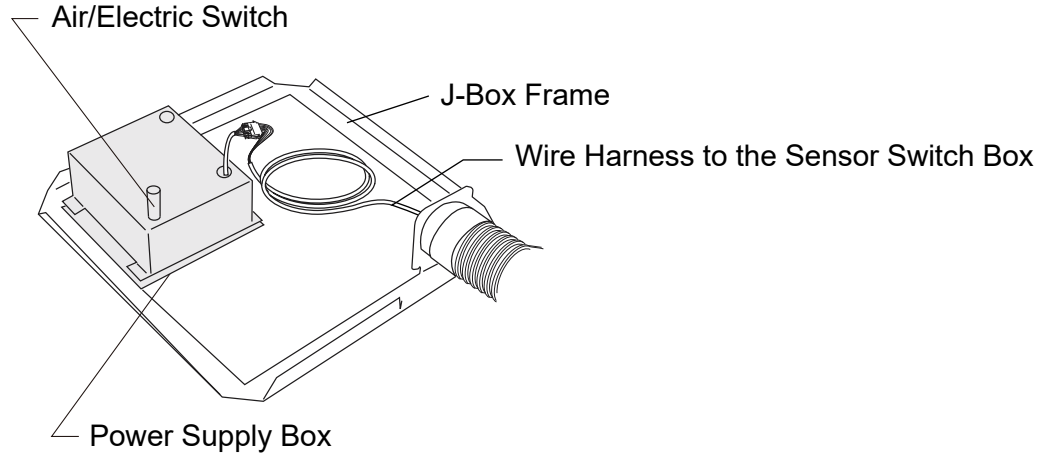

b). Connect the Air/Electric Switch to the 1/8" O.D. Brown tubing ⑦ which supplies air from the Dental Unit Master ON/OFF Switch on the delivery head.

c). Attach the 3-prong plug from the Power Supply Box to a grounded 120 VAC outlet.

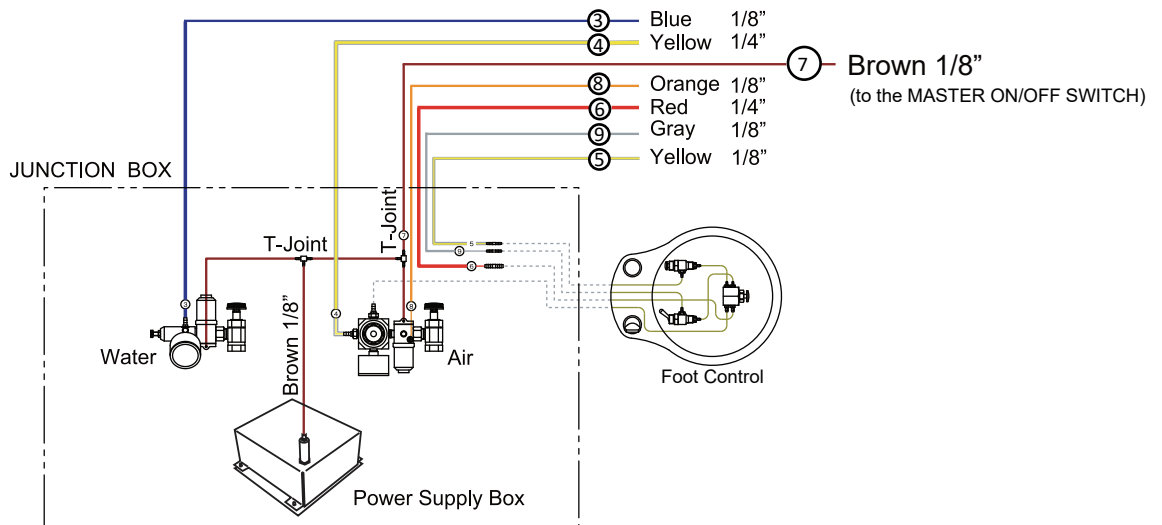
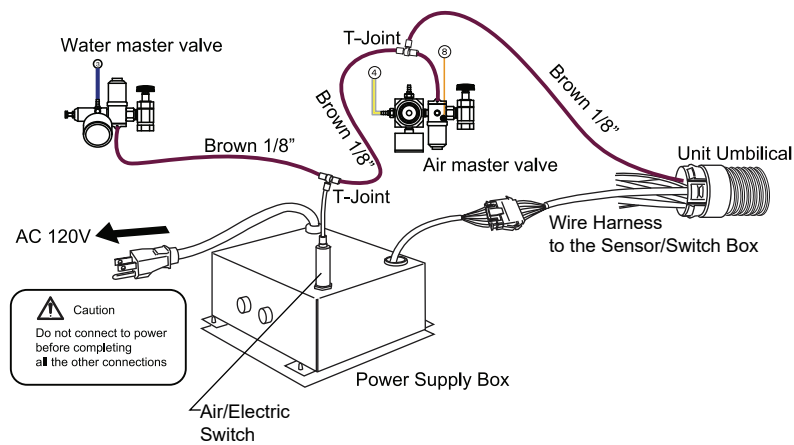



**BELMONT EQUIPMENT**  
101 Belmont Drive  
Somerset, NJ 08873-1204  
Phone: (800) 223-1192 • Fax: (732) 356-1035  
[www.belmontequip.com](http://www.belmontequip.com)