



**EX-1000**

PANORAMIC X-RAY  
OPERATOR'S  
MANUAL



# I N D E X

MAJOR PARTS IDENTIFICATION . . . . .	2
LAYOUT OF CONTROLS . . . . .	3
FUNCTION OF CONTROLS . . . . .	4
PATIENT POSITIONING CONTROLS & FUNCTIONS . . . . .	5
PATIENT POSITIONING . . . . .	6
OPERATING PROCEDURES . . . . .	7
TECHNICAL DATA . . . . .	9
MAINTENANCE AND MAINTENANCE RECORD . . . . .	11

## OBLIGATION OF THE USER

IT IS THE RESPONSIBILITY OF THE USER TO MAINTAIN THE EQUIPMENT IN COMPLIANCE BY FOLLOWING THE MANUFACTURER'S RECOMMENDED MAINTENANCE SCHEDULE. FAILURE OF THE USER TO PROPERLY MAINTAIN THE EQUIPMENT MAY RELIEVE THE MANUFACTURER, OR HIS AGENT, FROM RESPONSIBILITY FOR ANY INJURY, DAMAGE OR NON-COMPLIANCE, WHICH MAY RESULT.

# MAJOR PARTS IDENTIFICATION

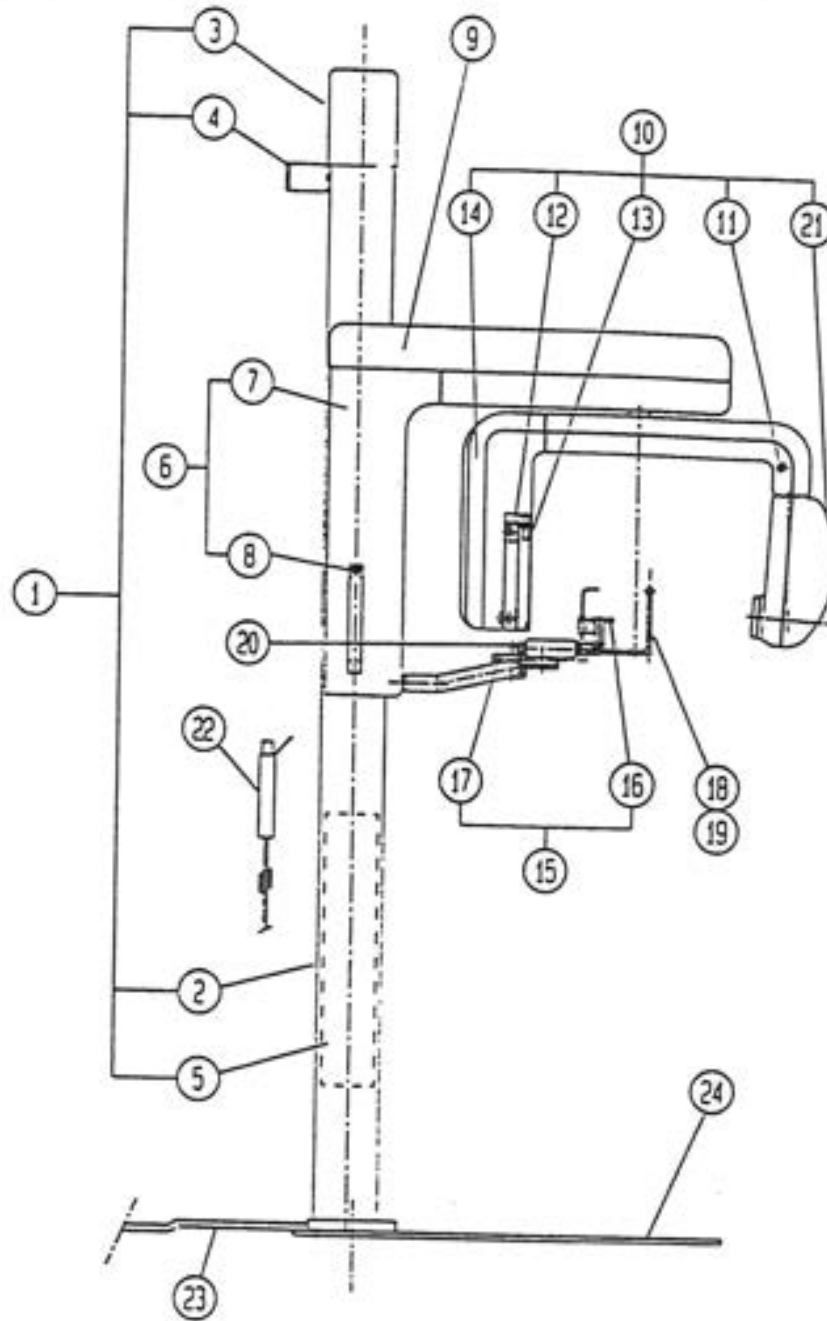

**ID No. DESCRIPTION**

- 1 Column Assembly
- 2 Column
- 3 Top Cover
- 4 Wall Bracket
- 5 Counterweight
- 6 Sliding Unit Assembly
- 7 Sliding Unit Body
- 8 Electro-Magnetic Lock Switch
- 9 Driving Unit Cover
- 10 Rotation Unit Assembly
- 11 Reset Switch
- 12 Cassette Holder Assembly

**ID No. DESCRIPTION**

- 13 Shield Plate
- 14 Cover for Controller
- 15 Chinrest Assembly
- 16 Chinrest
- 17 Chinrest Adjuster Knob
- 18 Head Holding Rod (Panorama)
- 19 Ear Holding Rod (TMJ)
- 20 Holding Rod Adjuster Knob
- 21 X-ray Head Assembly
- 22 Exposure Switch
- 23 Power Supply Cable
- 24 Base Plate (Option)

# LAYOUT OF CONTROLS

□ BELMONT  
10mA

WARNING THIS X-RAY UNIT MAY BE  
DANGEROUS TO PATIENT AND OPERATOR UNLESS  
SAFE EXPOSURE FACTORS AND OPERATING  
INSTRUCTIONS ARE OBSERVED

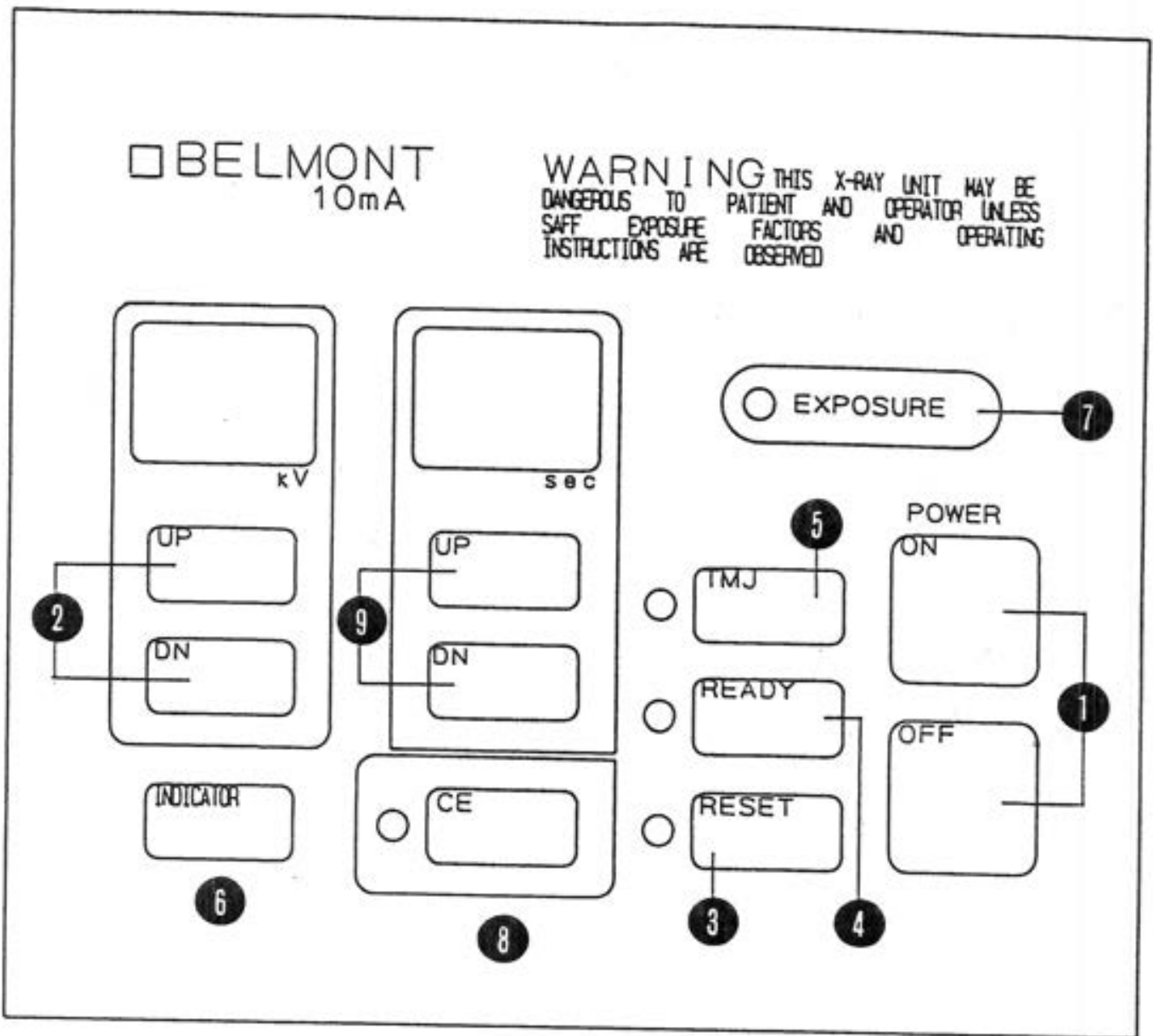

## FUNCTION OF CONTROLS

- ① MAIN POWER "ON" & "OFF" SWITCHES
  - Depressing POWER "ON" switch will turn the main power ON.
  - NOTE: Indicators show standard conditions of 75 kVp and 12 sec. when the main power is turned ON.
- ② kVp "UP" & "DN" SWITCHES
  - Tube potential can be adjusted by depressing "UP" or "DN(Down)" switch between 60 - 90 kVp by 5 kVp increment or decrement.
- ③ RESET SWITCH
  - Depressing this switch moves X-ray Head assembly and Cassette Holder to the starting position for panoramic or TMJ radiography.
  - NOTE: The switch located on the Rotation Arm has the same function. Refer to page 2, I.D. No.11.
- ④ READY SWITCH
  - Depress this switch after all the radiographing conditions are set, film cassette is mounted and patient is properly positioned.
  - An exposure can be made after the indicator lamp flashes three times and stays lit.
  - READY switch should be activated again after first exposure of TMJ radiography.
  - NOTE 1: READY switch turns ON only when the x-ray head assembly and the cassette holder are at Starting Position.
  - NOTE 2: READY status will be cancelled unless an exposure starts within 15 seconds. (If you are making an exposure after 15 seconds, depress the READY switch again.)
  - NOTE 3: READY switch will not function for 15 seconds after the main power switch is turned ON.
- ⑤ TMJ SWITCH
  - TMJ radiography can be made by depressing this switch.
- ⑥ INDICATOR SWITCH
  - By depressing INDICATOR switch, following three beam lines are available for 50 seconds.
    1. Median Line
    2. Frankfort Line
    3. Focal Trough Line
- ⑦ EXPOSURE INDICATOR
  - This lamp will remain illuminated while x-ray is being generated.
- ⑧ CEPHALOMETRIC SWITCH (MODEL X-CALIBER CM ONLY)
  - By depressing this switch, cephalometric mode can be selected.
- ⑨ SEC. "UP" & "DN" SWITCHES
  - Exposure time can be adjusted by depressing "UP" or "DN" switches.

## PATIENT POSITIONING CONTROLS & FUNCTIONS

### (1) CHINREST ASSEMBLY

#### (A) CHINREST

Plastic piece for patient to rest chin on during procedure.

#### (B) CHINREST ADJUSTER KNOB

- Turning this knob clockwise or counter-clockwise moves the whole chinrest assembly forward or backward through the focal trough.
- It is suggested to set the chinrest assembly at 0 (zero) position on scale before the patient positioning.

#### (C) BITE PIECE

- Plastic piece with a groove on the top and bottom that the patient fits upper and lower anterior teeth into and bites down.

### (2) HEAD SUPPORTING ASSEMBLY

#### (A) HEAD HOLDING RODS(for PANORAMIC)

Two plastic pieces to hold the sides of the patient's head.

#### (A') EAR HOLDING RODS(for TMJ)

Two plastic pieces with ear piece to hold the patient's head.

#### (B) HOLDING RODS ADJUSTER KNOB

To open or close Head Holding Rods or Ear Holding Rods.

### (3) INDICATING BEAMS ADJUSTERS

#### (A) FRANKFORT PLANE INDICATOR BEAM ADJUSTING LEVER

- Located on Sliding unit front, beside the Mirror.
- By sliding this lever, Frankfort Plane Indicator Beam moves up/down.

#### (B) FOCAL TROUGH INDICATOR BEAM ADJUSTING KNOB

- Located on Chinrest Ass'y.(opposite side of Chinrest Adjuster knob)
- By rotating this knob, Focal Trough Indicator Beam moves up/down.

### (4) ELECTRO-MAGNETIC LOCK SWITCH (OVERHEAD CARRIAGE RELEASE SWITCH)

- Located on upper portion of Grip of Sliding Unit.
- While the main power is ON, the entire Overhead Carriage and Cephalostat Ass'y are electro-magnetically locked at the position.
- By depressing this switch, Overhead Carriage and Cephalostat ass'y can be free and moved up/down. They can be locked at the place where the switch is released.

## PATIENT POSITIONING

### [1] PANORAMIC RADIOGRAPHY

- a) Open the Head Holding Rods fully.
- b) Adjust the height of Chinrest by moving Overhead Carriage up/down, so that the patient can stand upright and rest the chin on Chinrest.
- c) Depress Indicator Switch on Control Panel.  
Three Indicator beams come ON.

#### (1) Frankfort Plane

- Adjust beam height so that the beam hits the patient's miniscule of the ear (hole).
- Then adjust the patient's head as to beam indicates Frankfort Plane (from miniscule of the ear to bottom of the eye orbit).

NOTE1: If the chin is left too low, the x-ray of the dental arch will look something like a "smiling" line relationship.

NOTE2: If the chin is left too high, the x-ray of the dental arch will show a "frowning" line relationship.

#### (2) Median Line

- Adjust the patient's head so that the Median Line Beam comes to the center line of the patient's face.

#### (3) Focal Trough Line Beam

- This is the MOST IMPORTANT point to obtain the best radiographs.
- Adjust the beam height so that the beam comes approximately at lip end.
- Then adjust Chinrest forward or backward so that indicator beam falls at cuspid.

- d) Close the Head Holding Rods to support the patient's head.
- e) Patient is now positioned for a panoramic exposure.

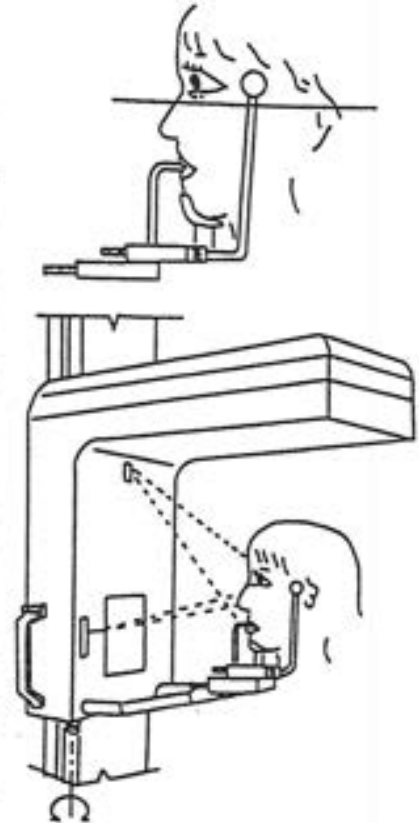

### [2] TMJ RADIOGRAPHY

- a) Remove the Chinrest and replace Head Holding Rods with Ear Holding Rods.  
Open the Ear Holding Rods fully. Then enter the patient into the machine.
- b) Move the Ear Holding Rods forward so that the scale shows 20mm forward from the center mark.
- c) Adjust the height of Ear Holding Rods by moving Overhead Carriage up/down, so that the patient can stand upright.
- d) Depress Indicator Switch on Control Panel. Indicator beams come ON.
  - (1) Frankfort Plane
    - Refer to [1] PANORAMIC RADIOGRAPHY, Item c) (1).
  - (2) Median Line
    - Refer to [1] PANORAMIC RADIOGRAPHY, Item c) (2).
- e) Carefully close the Ear Holding Rods to support the patient's head.
- f) Patient is now positioned for TMJ exposures.

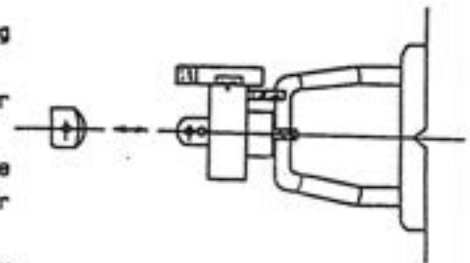

## OPERATING PROCEDURE

- a) Mount a loaded cassette on the cassette holder.
- b) Turn the unit ON.
- c) Depress the Reset switch on the control panel and wait for the Reset light to go out. The unit is now at Starting position.
- d) Position patient as described on page 6, "PATIENT POSITIONING".
- e) Select the technique factors with regard to the Technique Factor Table on page 8, considering the patient size.

NOTE 1: When the unit is turned ON, each technique factor is automatically set at standard conditions of 75 kVp, 12 seconds in Panoramic mode and 75 kVp, 15 seconds in TMJ mode.

NOTE 2: For TMJ Radiography, prior to the technique factor selection, depress the TMJ Switch on the control panel.

- f) Depress the Ready Switch on the control panel and wait for the Ready light to stay ON.
- g) Take the Exposure Switch on the coiled cord to a safe operator's position (as defined by your state's x-ray protection statutes).
- h) Instruct the patient to do the following:

- (1) Relax this takes only 12 seconds (Panoramic mode).
- (2) Swallow the air in your mouth and breath through your nose.
- (3) Place your tongue on the roof of your mouth.
- (4) Here we go.

NOTE: In case of TMJ Radiography, disregard the instructions above, and refer to j-1) on page 8.

- i) Depress the Exposure Switch. When the switch is depressed, the Exposure Warning Lamp will illuminate and the audible warning will sound. Do not release the Exposure Switch until the audible warning and the warning lamp terminates. Failure to keep the Exposure Switch depressed will result in the exposure being terminated prematurely.

NOTE: TMJ Radiography (quarterly divided) consists of a series of two exposures, 1st exposure for the diagnosis of TMJ with mouth closed and 2nd exposure for TMJ with mouth open. Exposure procedures for a series of two exposures are described from j-1) to j-3) on page 8.

## OPERATING PROCEDURE

- J-1) Instruct the patient that TMJ Radiography consists of two consecutive exposures and the following cooperation is needed;
- (1) Relax this takes approx. 15 seconds for each excursion.
  - (2) During the excursion, breath through your nose.
  - (3) During the first excursion, close your mouth.
  - (4) During the second excursion, open your mouth.
  - (5) Here we go.

- J-2) Depress the Exposure Switch. While the x-ray is generated, the Exposure Warning Lamp will illuminate and the audible warning will sound. Do not release the Exposure Switch until the first excursion ends and the unit starts to return. Failure to keep the Exposure Switch depressed will result in the exposure being terminated prematurely.

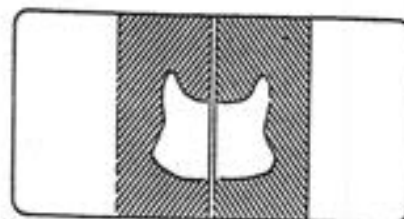

first exposure

- J-3) Depress the Ready Switch on the control panel again and wait for the Ready light to stay ON. Then depress the Exposure Switch again for the 2nd exposure and keep it depressed until the excursion is completed.

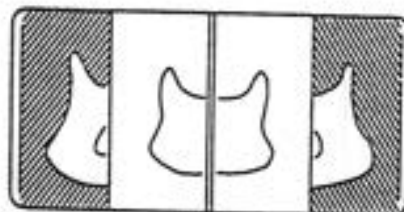

2nd exposure

- k) After use, turn the Main Power Switch OFF to prevent accidental exposures.

- l) Carefully help patient out of the unit.

- m) Remove cassette and develop film.

### STANDARD TECHNIQUE FACTOR

A G E	S E X	K V	M A
4 - 10	-	60 - 65	10
11 - 15	-	65 - 70	10
ADULT	FEMALE	70 - 75	10
ADULT	MALE	75 - 80	10

FILM: KODAK T-MAT G FILM (TMG)

INTENSIFYING SCREENS: KODAK LANEX REGULAR

DEVELOPING: 20° (68° F), 4 MINUTES IN TANK

27° (81° F), 5 MINUTES WITH AUTOMATED PROCESSORS

## TECHNICAL DATA

1. Maximum rated peak tube potential ..... 90 kVp
2. Rated peak tube potential ..... 60 - 90 kVp (5kVp in 7steps)
3. Rated tube current ..... 10 mA
4. Rated line voltage ..... 120 VAC
5. Line voltage range ..... 110 - 130 VAC
6. Range of line voltage regulation ..... 1 - 3 %
7. Maximum rated line current ..... 10 A at 90 kVp, 10 mA
8. Exposure time ..... 12 sec. at panoramic mode  
15 sec. at TMJ mode
9. Minimum filtration ..... 2.6 mmAl
10. Focal point measurement ..... 1.0 mm X 1.0 mm  
NOTE: Effective focal spot size .... 0.5 mm X 1.0 mm
11. S.I.D. .... 490 mm
12. Duty cycle ..... 1:15 (refer to NOTE below)  
NOTE: The exposure time in panoramic mode is 12 sec., therefore, 3 min. interval or "Non Use" period requires the user to wait before making another exposure. Because of the 15 sec. exposure time in TMJ mode, 3.75 min. waiting time must be allowed after each series of 2 exposures.
13. Leakage technique factor ..... 90 kVp, 0.63 mA  
NOTE: 0.63 mA is maximum rated continuous current for 10 mA with a duty cycle of 1: 15.
14. Film size ..... 6 inch X 12 inch
15. Magnification rate ..... 1.25
16. Tomographic orbit ..... Single axis, continuous rotation
17. Nominal roentogen output at the end of beam limiting device\*
  - a. Panoramic mode: 2.3 R/12 sec.  $\pm$  40% at 90 kVp, 10 mA
  - b. TMJ mode : 2.9 R/15 sec.  $\pm$  40% at 90 kVp, 10 mANOTE: at the distance of 450 mm from focal spot.

## TECHNICAL DATA

### 18. Half value layer\*

- a. Approx. 3.3 mmAl equiv. at 90 kVp
- b. Approx. 2.4 mmAl equiv. at 60 kVp

### 19. Maximum deviation of tube potential and tube current\*

- a. Tube potential: the selected kVp  $\pm$  15 %
- b. Tube current : 10 mA  $\pm$  10 %

\*NOTE: APPROX. VARIATION MAY BE REALIZED TO MEASUREMENT INSTRUMENTATION, MANUFACTURING TOLERANCES, AGE, INSTALLATION VARIABLES, AND USE HISTORY.

### 20. Timer accuracy: $\pm$ 5%

### 21. Measurement basis of technique factors

#### a. Peak tube potential

The potential difference across the x-ray tube during the conducting half cycle and results in an accuracy tolerance of  $\pm$  15 %, except as stated below;

From 0 - 0.3 sec., kVp may vary +35/-45 %

#### b. Tube current

The average mA value during a complete power line cycle, results in an accuracy tolerance of  $\pm$  10 %, except as stated below;

From 0 - 0.09 sec., mA may vary +150/-100 %

From 0.1 - 0.19 sec., mA may vary +100/- 75 %

From 0.2 - 0.3 sec., mA may vary + 35/- 45 %

#### c. Exposure time

Impulse time is directly related to power line frequency. Exposure time applies from the beginning of first conducting line impulse to the end of last impulse, results in an accuracy tolerance of  $\pm$  5 %.

# MAINTENANCE

MODEL X-CALIBER PANORAMIC X-RAY unit requires the following periodic maintenance checks being performed to ensure the unit is functioning within the manufacturer's specifications.

It is the responsibility of the owner of the unit to see that these maintenance checks are done once every 6 months and that they are performed by a trained, certified service technician.

The specific instructions to perform these checks are located within the X-CALIBER installation manual.

- A. Line Voltage and Line Voltage Regulation test
- B. Tube Current test
- C. Exposure Time test
- D. X-ray Field Size and Alignment test

## MAINTENANCE RECORD

Date of installation \_\_\_\_\_ / \_\_\_\_\_ / \_\_\_\_\_ By \_\_\_\_\_

<u>PERIOD</u>	<u>CHECKED DATE</u>	<u>CHECKED ITEMS</u>	<u>CHECKED BY</u>
6-Month	_ / _ / _	A B C D <input type="checkbox"/> <input type="checkbox"/> <input type="checkbox"/> <input type="checkbox"/>	_____
1-Year	_ / _ / _	A B C D <input type="checkbox"/> <input type="checkbox"/> <input type="checkbox"/> <input type="checkbox"/>	_____
18-Month	_ / _ / _	A B C D <input type="checkbox"/> <input type="checkbox"/> <input type="checkbox"/> <input type="checkbox"/>	_____
2-Year	_ / _ / _	A B C D <input type="checkbox"/> <input type="checkbox"/> <input type="checkbox"/> <input type="checkbox"/>	_____
30-Month	_ / _ / _	A B C D <input type="checkbox"/> <input type="checkbox"/> <input type="checkbox"/> <input type="checkbox"/>	_____
3-Year	_ / _ / _	A B C D <input type="checkbox"/> <input type="checkbox"/> <input type="checkbox"/> <input type="checkbox"/>	_____
42-Month	_ / _ / _	A B C D <input type="checkbox"/> <input type="checkbox"/> <input type="checkbox"/> <input type="checkbox"/>	_____
4-Year	_ / _ / _	A B C D <input type="checkbox"/> <input type="checkbox"/> <input type="checkbox"/> <input type="checkbox"/>	_____

 **Belmont**

**EQUIPMENT CORPORATION**

101 Belmont Drive, Somerset, N.J. 08873  
(908)469-5000 Toll Free(800)223-1192 Fax(908)526-6322

9601MA