

X-CALIBUR V

DENTAL CHAIR

BEL-50

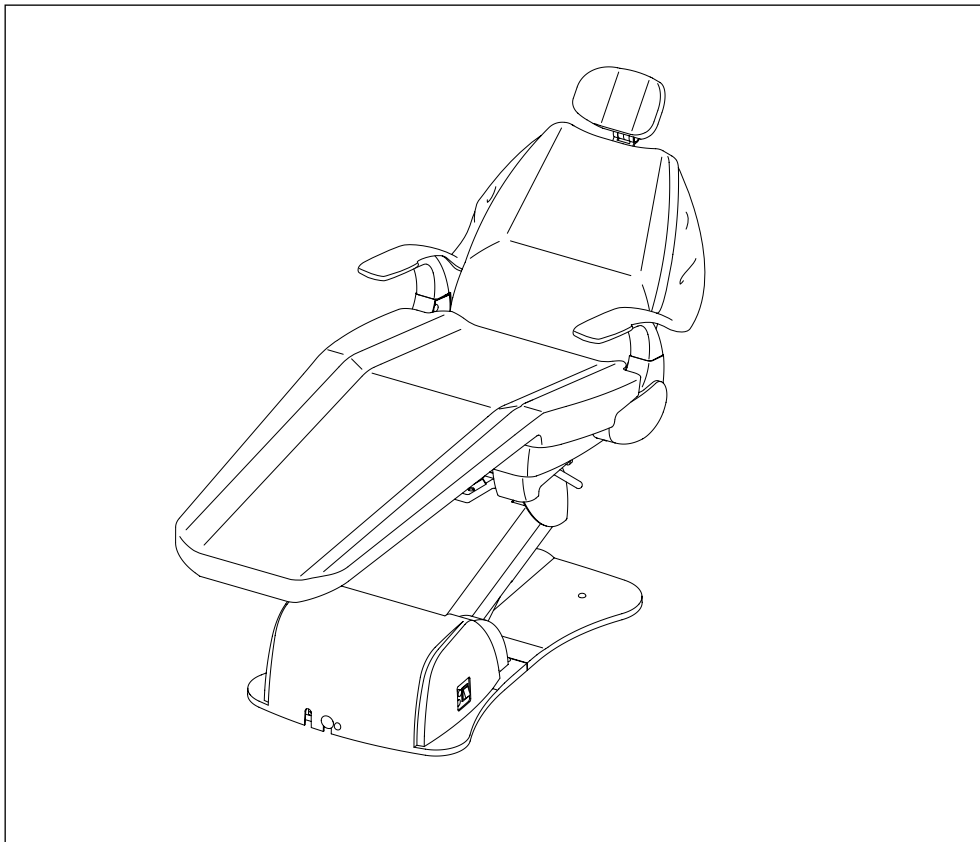

INSTALLATION INSTRUCTIONS

IMPORTANT

This manual provides installation instructions for the BEL-50 Chair. The instructions contained in this booklet should be thoroughly read and understood before installation of the chair. After the installation has been completed, keep this manual in a safe place.

 **Belmont**[®]

AEFS97D0

Table of Contents

1. Overview and major components -----	1A
2. Dimensions and Specifications -----	2A
3. Introduction -----	3
4. Installation -----	4
5. Adjustment -----	8B
6. Electric Diagram -----	10B

Intended Use of the Product

This product is intended for the exclusive use for diagnoses, treatments and relative procedures of dentistry, and must be operated or handled by the qualified dentists or by dental staffs under the supervision of the dentist. Such dentists or dental staffs should instruct and/or assist the patients to approach to and leave from the product. Patients should not be allowed to operate or handle the product unless he/she is so instructed.

Environmental Requirements

Operating	Ambient Temperature	41°F ~ 104°F (5°C ~ 40°C)
	Humidity	30% ~ 75%
	Atmospherical Pressure	10.2psi ~ 15.4psi (700hpa ~ 1060hpa)
Storage	Ambient Temperature	14°F ~ 122°F (-10°C ~ 50°C)
	Humidity	10% ~ 80%
	Atmospherical Pressure	8.7psi ~ 15.4psi (600hpa ~ 1060hpa)

Classification

- Protection against electric shock : Class I Equipment, Type B Applied Parts  (Headrest, Backrest and Seat cushions)
- Protection against water ingress : Chair (IPX0), Foot control (IPX1)
- Equipment not suitable for use in the presence of a flammable anesthetic mixture with air or with oxygen or nitrous oxide.
- Mode of operation : Non-continuous operation. ON time :3min. OFF time : 15 min

CAUTION

This product may be affected by sources that generate excessive electromagnetic waves. Do not install this equipment close to such devices such as elevators or communication equipment, including cellular telephones. Do not position this equipment so that it is difficult to access the main power supply outlet that the power plug of this chair is connected to.

Symbol



Applied part complying with the specified requirements of IEC60601-1:2005 to provide protection against electrical shock, particularly regarding allowable patient leakage current and patient auxiliary current.



Caution, warning or note

1. OVERVIEW, MAJOR COMPONENTS

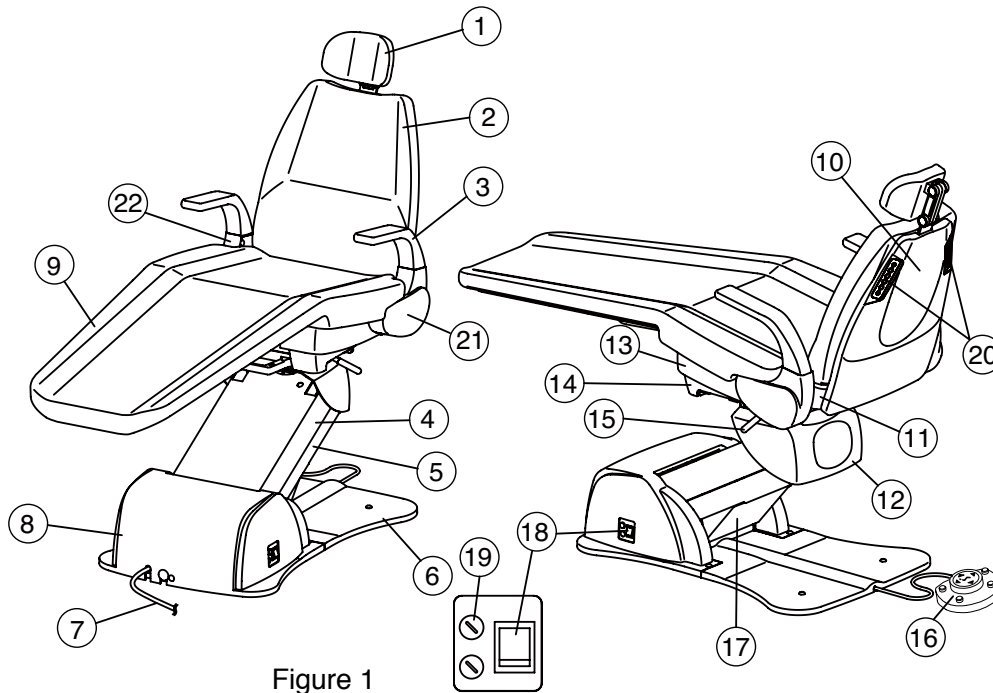

Figure 1

- | | | |
|-----------------------|---------------------------|-----------------------------|
| 1. Headrest Assembly | 9. Seat Cushion | 17. Sub Link Cover(Lower) |
| 2. Backrest Cushion | 10. Backrest Cover | 18. Main Power Switch |
| 3. Armrest | 11. Seat Back Support | 19. Fuse Holder |
| 4. Main Link Cover | 12. Dome Casting Cover | 20. Backrest Control Panels |
| 5. Sub Link Cover | 13. Tilt Cover | 21. Side Frame (Left) |
| 6. Base Cover | 14. Rotating Flange Cover | 22. Side Frame (Right) |
| 7. Power Supply Cable | 15. Rotation Lock Lever | |
| 8. Pump Cover | 16. Foot Control Ass'y | |

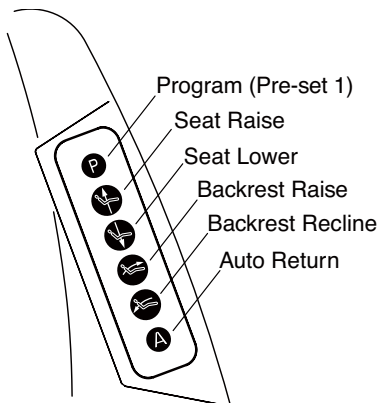

Figure 2
BACKREST CONTROL

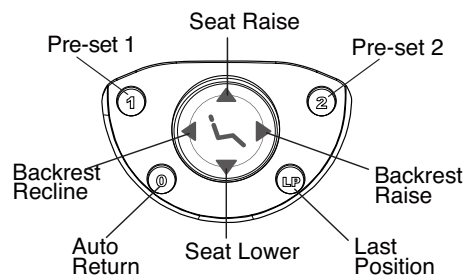
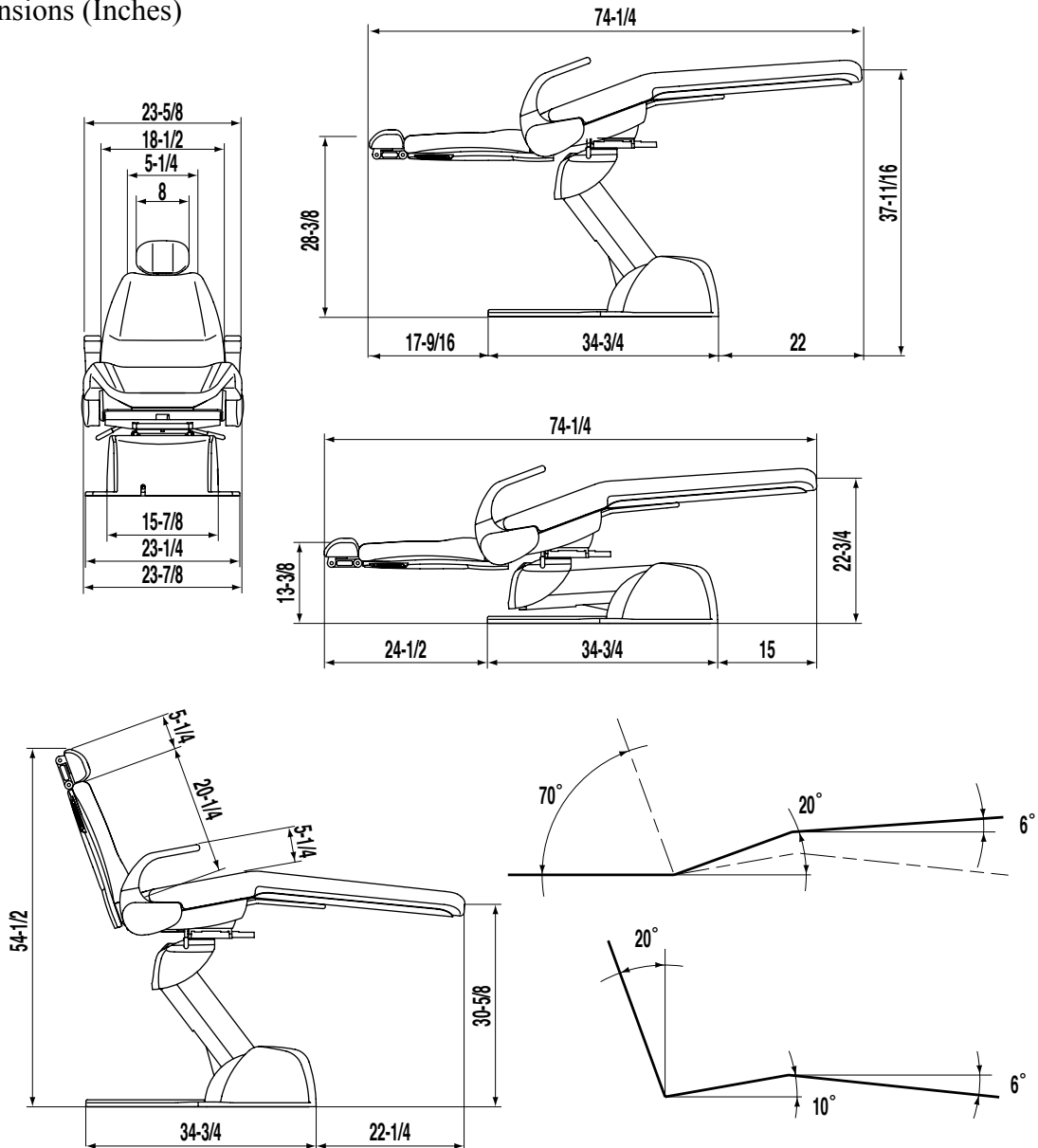

Figure 3
FOOT CONTROL

2. DIMENSIONS and SPECIFICATIONS

2-1. Dimensions (Inches)



2-2. Specifications

- * Sealed hydraulic system powered by 3.5 A motor pump
- * Base plate: 1/2" steel
- * Bearings at link points - low friction in steel jacket.
- * Steel seat cradle
- * Steel backrest support
- * Electrical requirements : AC120V/60Hz/3.7A
- * Fuse for power supply : 10A/125V (Current rating : 750A at 250VAC) Fast-blow
- * Fuse for relays : 1.25A/125V (Current rating : 750A at 250VAC) Fast-blow
- * Hospital grade plug
- * Base component housing formed from solid color acrylate styrene acrylonitrile (ASA ,V0)
- * All exposed ferrous parts covered with corrosion-resistant paint or plating
- * Weight: 381 lbs. (173 kg)

3. INTRODUCTION

3-1. Precautions for Installation

- Keep the equipment away from water.
- Keep in a circumstances safe from influence by temperature, humidity, wind, sun light, air containing salts and minerals.
- Care about stability such as inclination, vibration and impact, including handling and transportation.
- Do not keep the equipment in a place where chemicals are or where gas is emitted.
- The floor construction required to safely support the chair and delivery system is 105 lbs./ft² (500kg/m²) at minimum.
- During lifting and unpacking of the chair, make sure to hold only the designated parts.
- Do not drop or hit the chair.
- After the chair is unloaded from the palette and placed at the desired location, please make sure to remove the shipping bolt with the red tag. Damage to chair may occur if shipping bolt is not removed prior to chair operation.
- Do not connect to power supply other than AC120V 60HZ.
- Ground chair properly prior to turning power on.
- Chair base must be anchored to the floor for maximum stability.
- Refer to the installation manual of the chair and dental unit (if it is to be used) prior to, and during installation.
- When the installation process has been completed, verify that all the mechanical and electrical functions are working properly and that there is no evidence of oil leakage.
- Protective footwear and thick gloves are highly recommended at unpacking.
- Do not modify this equipment.
- In the case separation from any electrical poles is necessary, pull of the power plug from the power supply outlet.

3-2. Required Tools

The following tools are necessary for installation of the chair.

Phillips screw driver #2

Allen key wrenches, metric size

4. INSTALLATION

4-1. Unpacking the chair base

- 1) Place chair carton close to installation location.

Remove all the staples fixing the carton to pallet, or cut the carton just above the stapled line, and remove the carton.

(See Figure 1.)

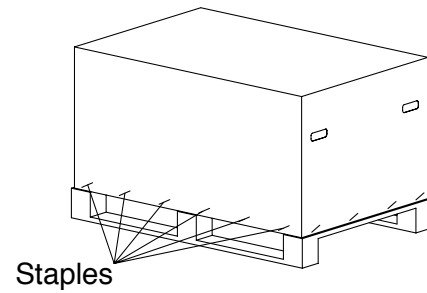

Figure 1

- 2) Using a 10mm socket, loosen and remove two packing screws holding the chair base into pallet. (See Figure 2.)

- 3) Lift chair base from pallet into the installation location.

Be sure to lift chair under the side frame and main link axis as shown in Figure 2.

⚠ CAUTION

Do not lift chair by toeboard bar

⚠ CAUTION

Do not connect in the power supply line before removing the red tagged shipping bolt.

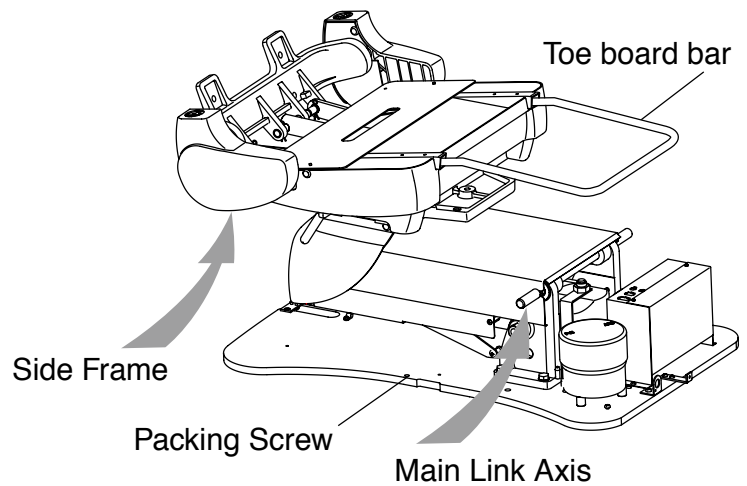

Figure 2

- 4) Before attaching chair to the electrical power source, remove red shipping bolt from the seat structure using a 13mm socket. (See Figure3.)

- 5) Remove the following items from chair packaging:

- Backrest Frame Assembly
- Metal Seat
- Plastic Base Cover
- Small Carton Box Containing Armrests, Headrest Mechanism and Bag of Hardware.

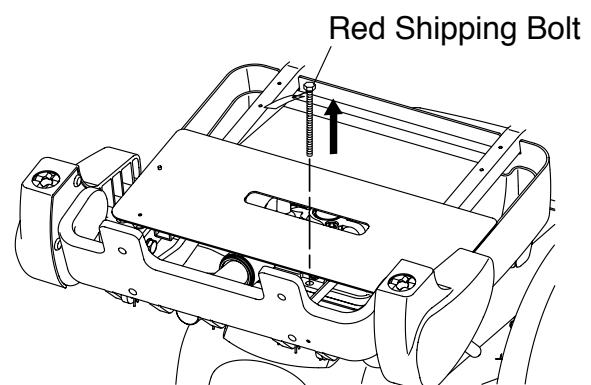

Figure 3

4-2. Installation

- 1) Plug chair into 120VAC outlet.

⚠ CAUTION

To avoid the risk of electric shock, this equipment must only be connected to a supply mains with protective earth. Grounding reliability can only be achieved when the equipment is connected to an equivalent receptacle marked HOSPITAL ONLY or HOSPITAL GRADE.

- 2) Turn on the main power switch located on the left side of the pump cover. A green lamp will illuminate.

⚠ CAUTION

Operate the Main Power Switch by hand only. Turn off the main switch after daily operation.

⚠ NOTE

Do not touch a switch on the foot control during the main power switch is being turned on.

- 3) Raise the seat by foot switch.

- 4) Remove the side cover and attach each armrest to side frame as shown in Figure 4 (it may be necessary to lightly lubricate armrest shaft with silicone lube).

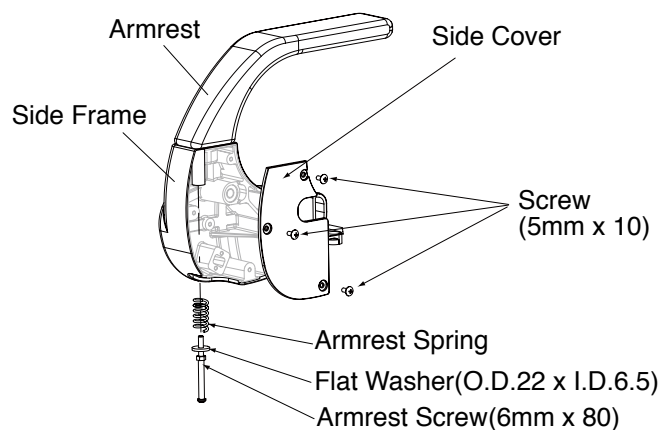

Figure 4

- 5) Remove 2(5mm x 8) phillips head screws that secure the plastic backrest cover to the metal backrest frame (Figure 6b). Using a 10mm hex key wrench, attach backrest frame to seat back support using 4(10mm x25) socket head cap screws.(See Figure 5 a.)

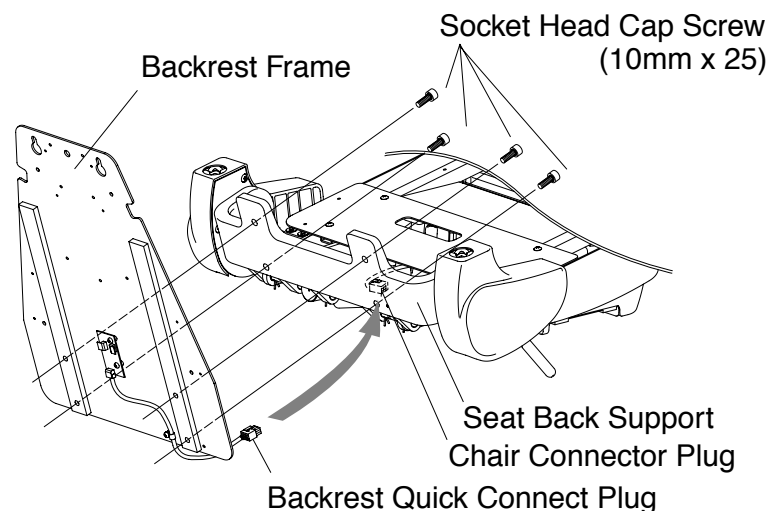

Figure 5 a

- 6) Connect backrest quick connect plug to chair connector plug (tie up the excess wire harness with a cable tie). (See Figure 5 a.)

- 7) Attach metal seat to seat frame, using 4(5mm x 6) phillips head screws.
(See Figure 5 b.)

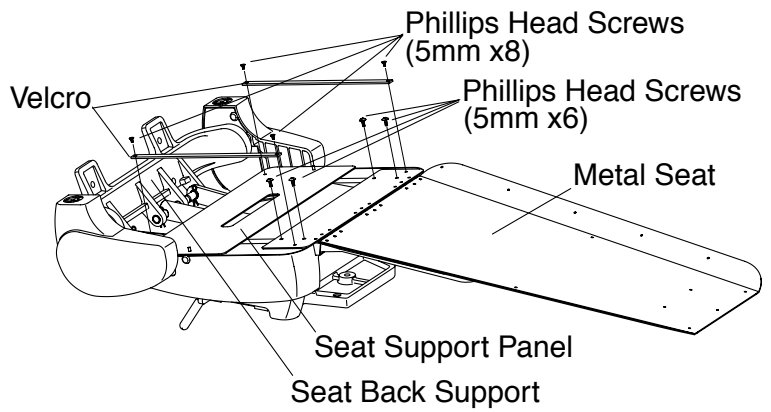

Figure 5 b

- 8) Fasten 2 velcro strips to holes on metal seat and seat support panel using 4(5mm x 8) phillips head screws, as shown in figure 5b.

- 9) Re-attach plastic backrest cover to backrest frame, as follows;

- a) Insert backrest cover alignment bolts into eyelet holes in backrest frame, as shown in figure 6a.
- b) Connect wire harness from backrest membrane switches to connector PC Board on the Backrest Frame.

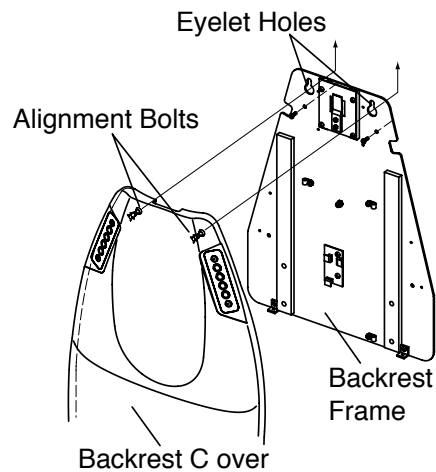

Figure 6a

- c) Press backrest cover against backrest frame and push backrest cover upward. Make sure the 2 small threaded brackets on the lower edge of the backrest frame are inside of the backrest cover.

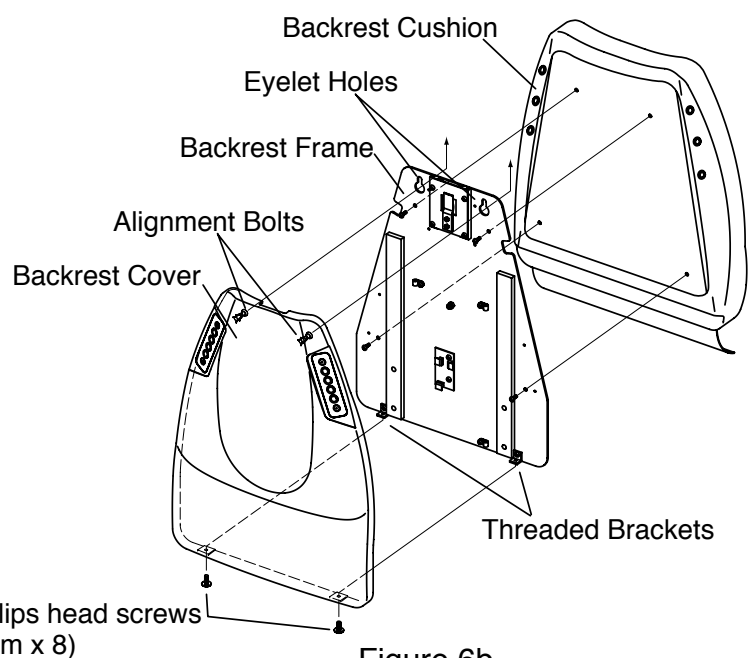

Figure 6b

- d) Secure backrest cover to backrest frame using 2 (5mm x 8) phillips head screws, as shown in figure 6b.

10) Attach headrest cushion to headrest mechanism using 4(10-24 x 3/4) phillips flat head screws and slide headrest bar into opening in top of backrest. (See Figure 6c)

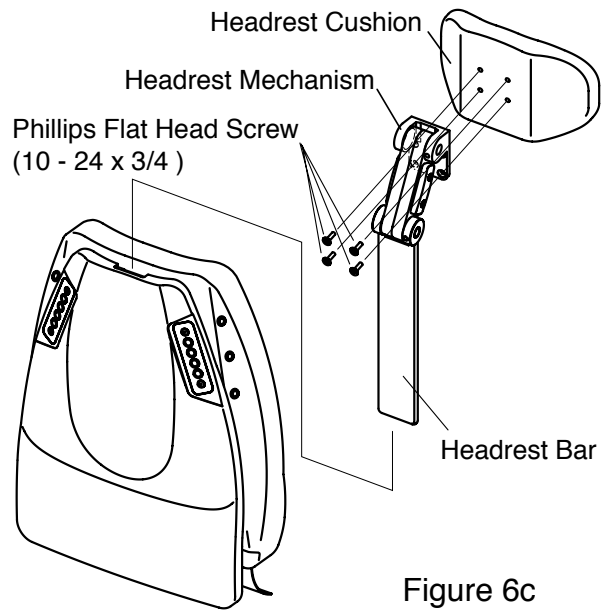

Figure 6c

11) Locate the red warning tag which is attached by a string to the rubber air vent plug in the pump reservoir. Normally a brisk tug on this tag will release the plug without the need to open the pump covers. (See Figure 7)

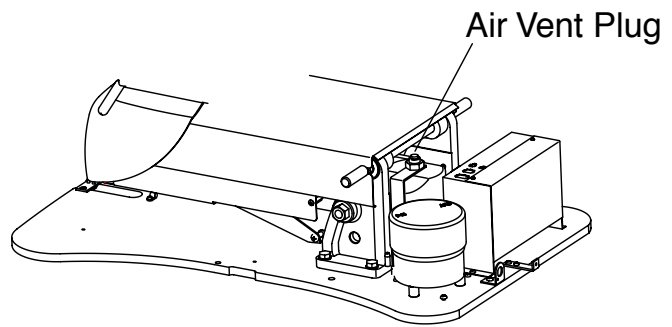

Figure 7

12) Using a phillips screwdriver, attach plastic base and pump covers to the base plate with 5 (5mm x 12) screws with countersink washers & plastic screw caps. (See Figure 8)

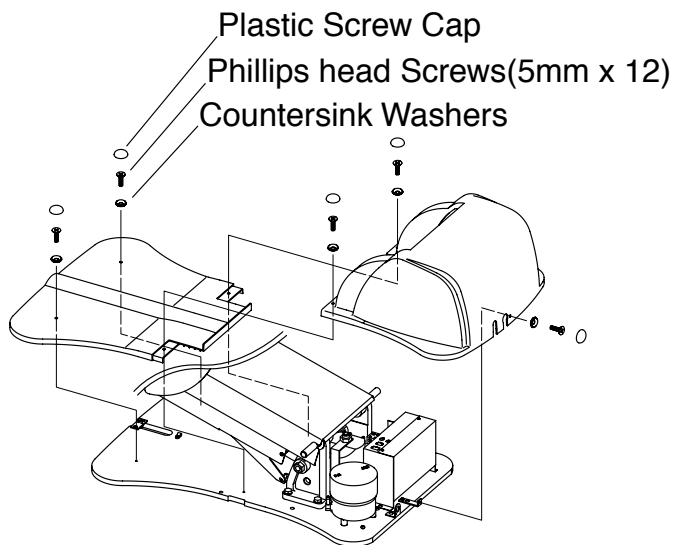

Figure 8

13) After the installation has been completed, check all the chair functions as per operation manual.

5. ADJUSTMENT

5-1. Speed Controls (Figures 9a and 9b)

Seat lowering speed and backrest reclining speed can be adjusted by the speed control knob on the solenoid valve block. The solenoid valve numbers and functions are shown in Fig.9b.

A. Remove the pump cover.

The solenoid valve block is located on the left side at the front of the chair base. Each speed control knob is located on the rear side solenoid valve block.

B. Loosen the lock nut for the speed control knob.

C. Turning the speed control knob clockwise to decrease the speed and turning counterclockwise to increase the speed.

D. After adjustment, tighten the lock nut and reattach the pump cover.

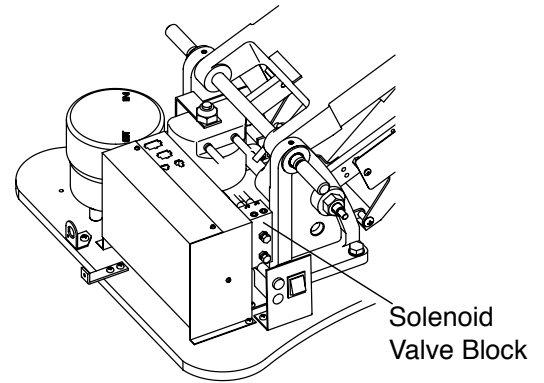
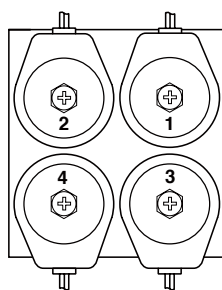

Figure 9a



Solenoid Valve Functions

SV1 : Seat Lifting

SV2 : Seat Lowering

SV3 : Backrest Raising

SV4 : Backrest Reclining

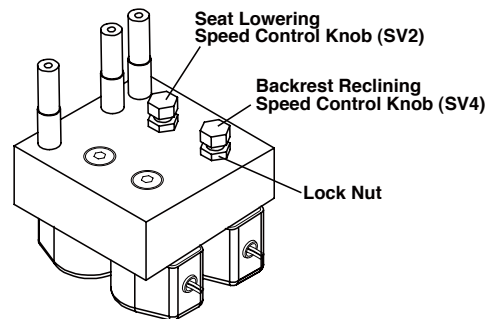

Figure 9b

⚠ CAUTION

The chair movement will be locked if the speed is reduced excessively.
Oil may leak from the speed control knob if the speed is increased excessively.

5-2. Setting Seat Motion Control Limits (Figures 10 & 11)

Raise the seat half way up.

Turn off the power.

Remove the pump cover for access to the chair control PCB.

Remove the PCB enclosure cover by unscrewing two screws. Turn on power.

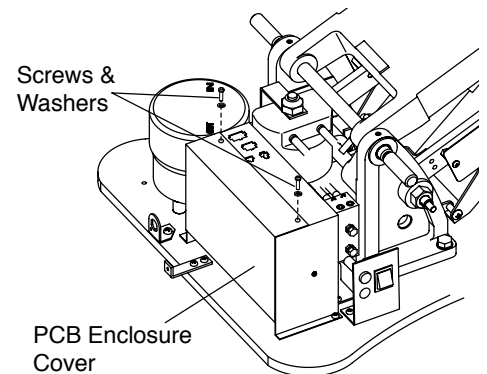

Figure 10

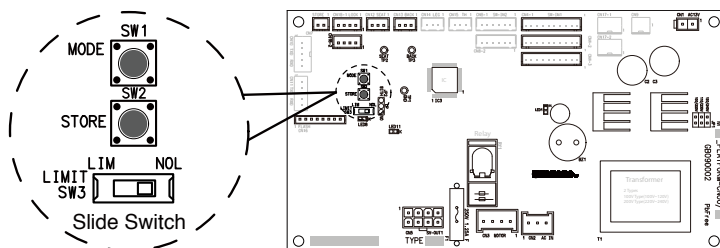

Figure 11 (Control PCB)

Set the slide switch on upper right corner of the PCB to the "LIM" position. Red LED will light and beeper will sound at 1.5 second intervals.

IMPORTANT

To avoid a malfunction when setting lower limit, make sure that there is clearance between the safety plate and the chair base.

If a swing mounted delivery system is attached to the chair, set lower travel limit so delivery system components do not contact chair pump and cantilever lift arm covers.

Using the foot control, backrest controls or optional touchpad, move the seat to the desired position (seat low, seat high, backrest recline and backrest up).

Press and release red button located on the PCB marked "Store", then using the foot control, backrest controls or optional touchpad press and release the desired limit you wish to set. Beeper will sound.

Move slide switch to position marked "NOL" and test stored limit function(s).

Example: Setting the Lower Seat Limit

- 1) Slide the Normal-Limit switch to the "LIM" position
- 2) Move the seat base to the desired lowest position. (See Important box on above)
- 3) Press and release the " Store" button on the PCB
- 4) Press and release the seat base down switch using the foot control, backrest controls or optional touchpad. A beeper will sound.
- 5) Slide the Normal-Limit switch to the "NOL" position.
- 6) Raise the seat base using the foot control, backrest controls or optional touchpad and then lower it to be sure it stops at the desired position.

MEMO



BELMONT EQUIPMENT, Division of Takara Belmont, USA, Inc.

101 Belmont Drive Somerset, New Jersey 08873 U.S.A. TEL.:(732) 469-5000 / (800) 223-1192 Fax.:(732)356-1035

www.belmontequip.com

TAKARA CO, CANADA LTD.

2076 S. Sheridan Way, Mississauga, Ont., L5J2M4, Can. TEL.:(905) 822-2755 Fax.:(905)822-6203

www.takarabelmont.ca



TAKARA BELMONT CORPORATION (Manufacturer)

2-1-1, Higashi-shinsaibashi, Chuo-ku, Osaka, Japan TEL.: 81-6-6213-5945 FAX.: 81-6-6212-3680

Printed in Japan 2013-09